



BREVINI[®]

Motion Systems

DC6A1A1_B90-000R1
11 2022



1800-OILSOL
1800-645765

<https://oilsolutions.com.au/>

sales@oilsolutions.com.au

Product Catalog

Brevini[®] Power Units

DTR Power Packs

Custom mini powerpacks for telescopic dock levelers

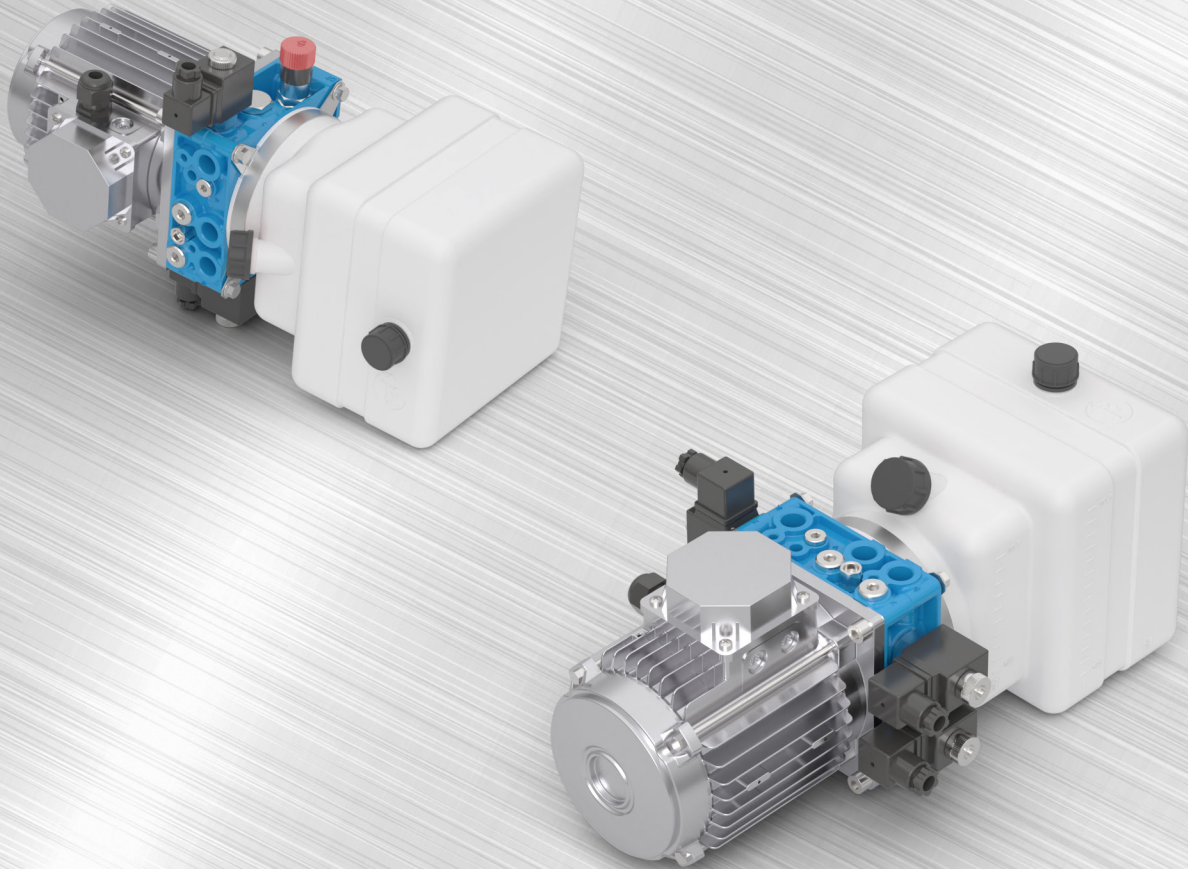

DTR Power Pack

Easy to assemble, compact electro-hydraulic unit
with high flexibility and modularity



Introduction	2
Endhead configuration	3
Power pack sections	4
Selection code	5
Endhead overall dimensions	8
Cavities dimensions	9
Section I - Endhead choice	10
Section II - DTR Cavities	11
Cavity E	11
Cavity D	12
Cavity B	13
Cavity G	14
Cavity 6 (optional)	15
Cavity H	16
Section II - DTR Ports A-P-C-X-L	17
Section III - Pumps	18
Section IV - Tanks / Section V - Tubes kit	20
Section VI - AC Motors	28
Section VII - Transmission kit AC motors	32
Section VIII - Accessories (optional)	33
Example	34
Assembly Instruction	35

Dana has introduced the introductive index, page symbols and bookmarks, which allow you to arrive and print the relevant section faster.

Clicking the Dana logo at the bottom page, you'll come back to the index.



The DTR series power pack is an easy-to assemble, compact, electro-hydraulic unit. It offers application driven solutions for any kind of telescopic dock levellers. This catalogue has been written to help the user to choose the components for the power pack required for the specific application. However, the catalogue cannot foresee all the combinations that may be executed, so in some cases it may be necessary to consult our local Dana Sales. You can chose from a wide variety of components with the following specifications:

- Gear pumps - Group 1 - from 0.90 to 4.3 cc. Single and triple-phase motors with power ratings of up to 4 Kw - in a standard version or built to the customer's specifications (with minimum overall dimensions)
- Tanks in sheet steel with capacities of up to 12 litres
- Tanks in plastic with capacities of up to 10 litres

A fundamental part of the power pack is the endhead, which is made of die-cast aluminum alloy. The parts and dimensions of this component are shown below.

Operating limits

- Intermittent peak pressure: 220 bar (depending on pump type)
- Maximum flow rate: 20 l/min
- Maximum operating temperature:
 - 80°C (with sheet steel tank)
 - 70°C (with polyethylene tank)
 - 60°C (with polypropylene tank)
- Mineral-based hydraulic fluid: ISO 6743-4 (DIN 51524)
 - Minimum viscosity: 12 mm²/s
 - Maximum viscosity: 80 mm²/s
 - Maximum viscosity at start-up: 500 mm²/s
- Minimum ambient temperature -15°C
- Maximum ambient temperature 40°C (with peaks of 50°C)
- The validation of the endhead follows a life-test with 210 bar pulsed pressure repeated for 200.000 cycles



Operating pressure is controlled by the maximum pressure valve and the type of pump used (in terms of performance) may be determined by the maximum pressure valve. Therefore, it is essential not to change the maximum pressure valve. If necessary, contact our technical service.

Installation

1. The power pack must be mounted using the M10 holes on the endhead.
2. The power pack must not come into contact with sheet metal, protective guards or any parts that may vibrate and transmit noise.
3. The ports on the endhead have been identified by the letters X-L-P-C-A. The hydraulic connection must be made with fittings with cylindrical thread and with copper or rubber sealing gaskets (O-rings).
4. After the electrical connections have been made, check the direction of motor rotation by executing short pulses of 1 second each (max.): the motor must turn anti-clockwise, as shown in the figure.

The tank must be filled with new mineral-based, ISO 6743/4 fluid:

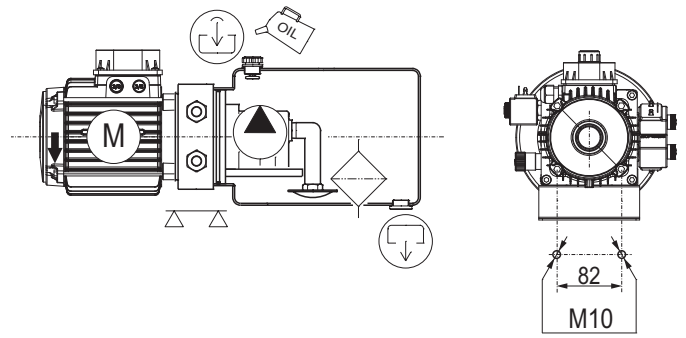

it is important to filter the fluid while filling the tank.

Symbology & Abbreviation

	Important data/information or Operations that may create a dangerous situation to persons, animals or property are indicated by the symbol on the left.
	Procedures that require special attention to obtain proper system operation are indicated by the symbol on the left.
	Mounting endhead side
	Ground floor
	Electrical connection boxes on AC motors
	Fill plug with breather and level stick
	Fill plug with breather
	Standard plug (closed)
	Standard oil fill plug
	Fill plug with breather
	Fill plug
	Fill plug with check valve
	Fill plug with back check
	Drain plug with magnet
	Plug (or level stick) with visual indicator
	Drain plug
	Tightening torque to be applied, in Nm
HPU	Hydraulic power unit
AC	Alternating current
DC	Direct current
RV	Relief valve
CW	Clockwise
*	Fields to be completed

Power pack endhead configuration

DTR

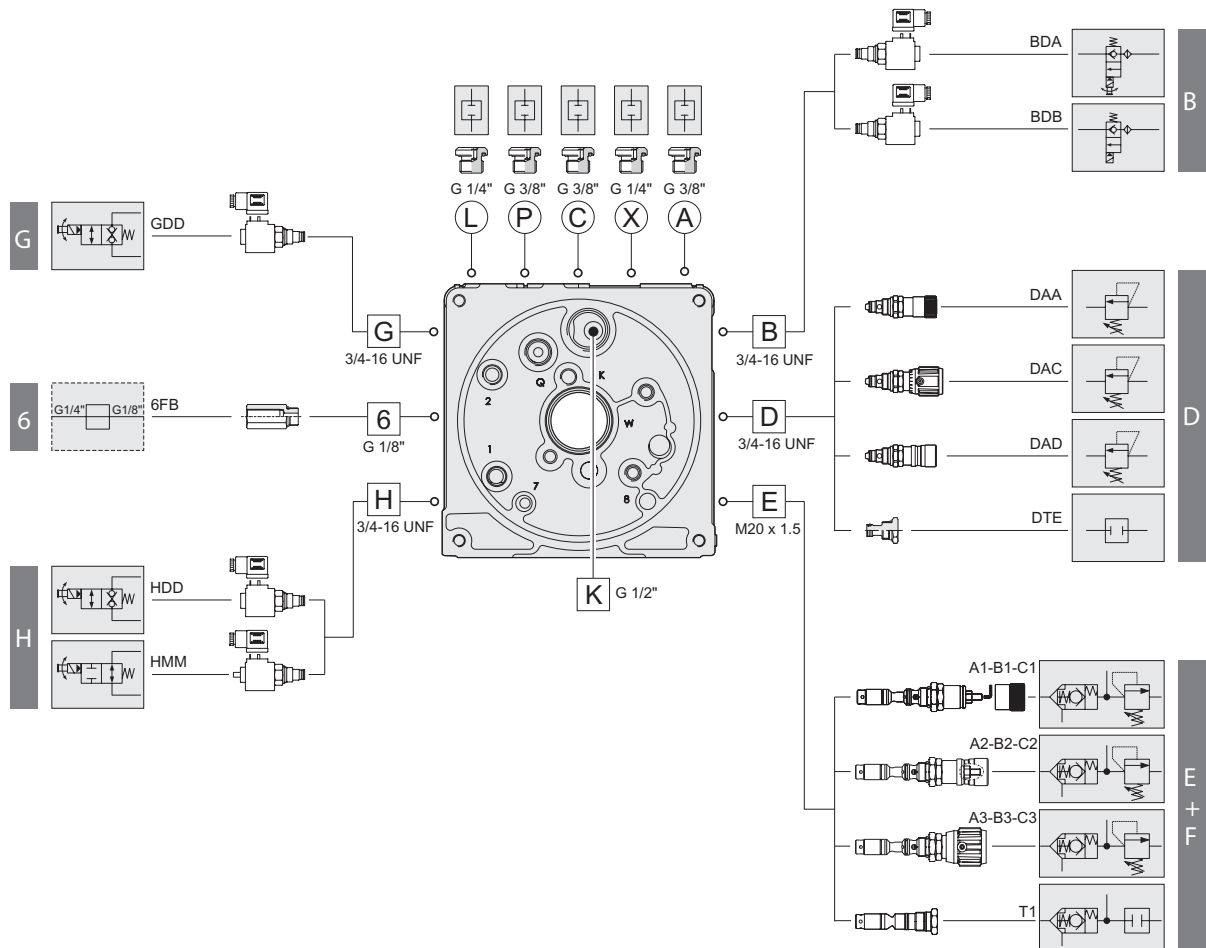

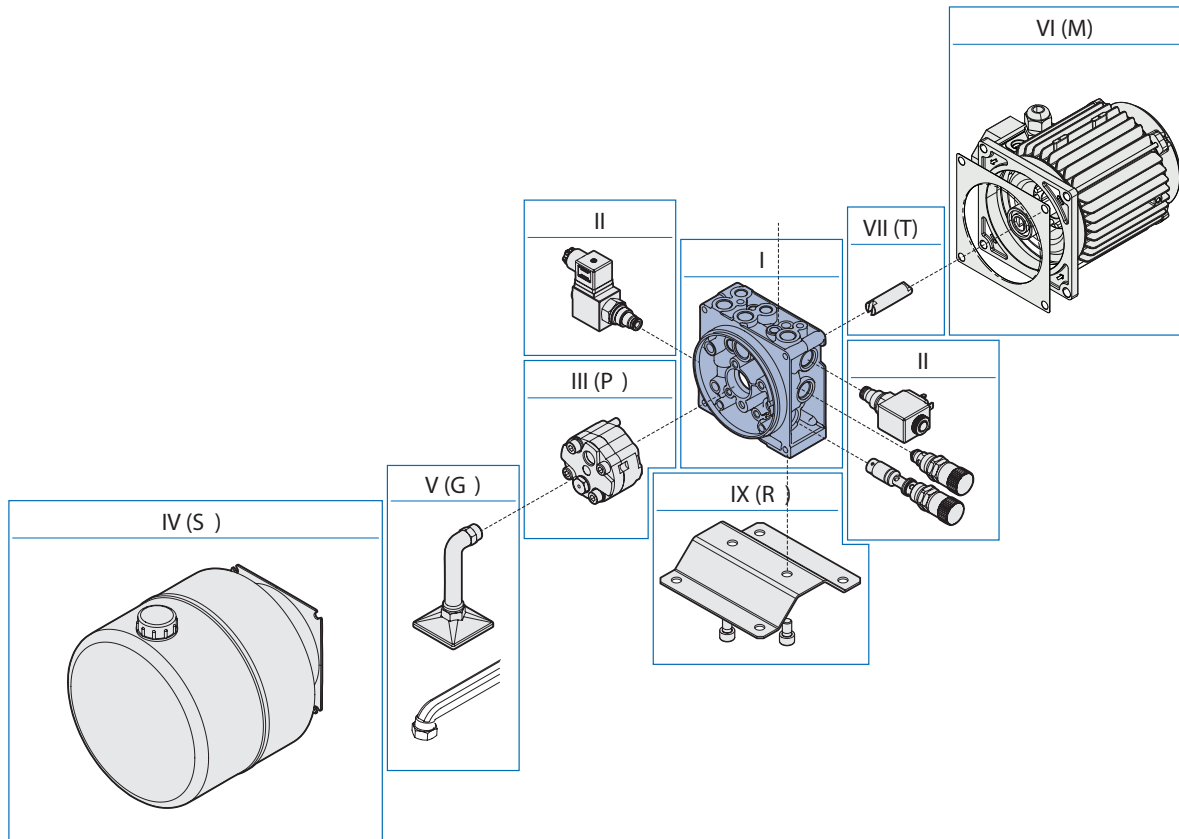

With its great modularity, the DTR series of power packs can create multiple configurations which satisfy requirements in a wide range of applications.

To make it easier to choose components, the power pack is subdivided into sections.

Section I - Serie, Flange Type, Valves on Cavity E+F

DTR Series Powerpacks are based on the Flange features.

The Flange is the core of the unit, on the flange are mounted all the valves, the pump, the motor and the reservoir.

The DTR Flange is available in several Versions (with different tooling options).

The Flange Version must be chosen depending on the type of Hydraulic Circuit Layout required.

Together with the Flange Version, it is required to select the Valves to be mounted in the Various Cavities E+F (Main Pressure Relief Valve).

Section II - Valves

Depending on the Type of Hydraulic Circuit Layout to be realized, it is required to select the Valves for each of the available Cavities. In order to correctly build up the Ordering Code, it is required to use the following procedure.

Peripheral Cavities (it is mandatory to mention all the Cavities in sequential Order): starting from Cavity D, mention all the Cavities and the Valves, Plugs or Fittings to be mounted in said Cavity. Internal Cavities, mention the Internal Cavities where a Valve (usually a Return Line Valve) is mounted. Outputs, see description in the Table.

Section III- Pumps

It is mandatory to mention this section, defined by the letter P.

Depending on the required features, select the pump from the table provided.

Section IV - Tanks

This section is defined by the letter S.

Depending on the required features, select the reservoir from the list provided.

If no Reservoir is required, and also no Suction / Return Kit is required, please omit this section.

If no Reservoir is required, but a Suction / Return Kit is required, please jump to Section V (defined by letter G).

Section V - Tubes Kit (suction and return, only for tanks on the catalog)

This section is defined by the letter G.

In order to define this Section, please select the Reservoir Type anyways.

Section VI - Motors

This section is defined by the letter M.

Depending on the Type of Hydraulic Circuit Layout to be realized, it is required to Select the Motor Type.

If no Motor is required, and no Transmission Kit is required, please omit this section.

If no Motor is required, but a Transmission Kit is required, please jump to Section VII (defined by letter T).

Section VII - Transmission Kit (only for motors on the catalog)

This section is defined by the letter T.

Select the kit as per Table provided.

Section VIII - Accessories

This section it is not mandatory, is defined by the letter R

Check the available options in the list provided.

Accessories must be listed in Alphabetical Order.



SECTION I - SERIE, ENDHEAD, VALVES ON CAVITY 1 AND 1R

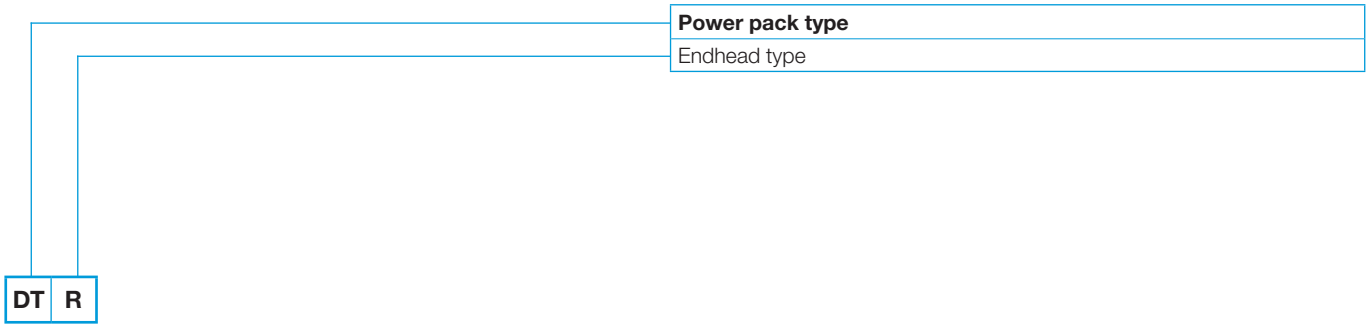

SECTION II - VALVES

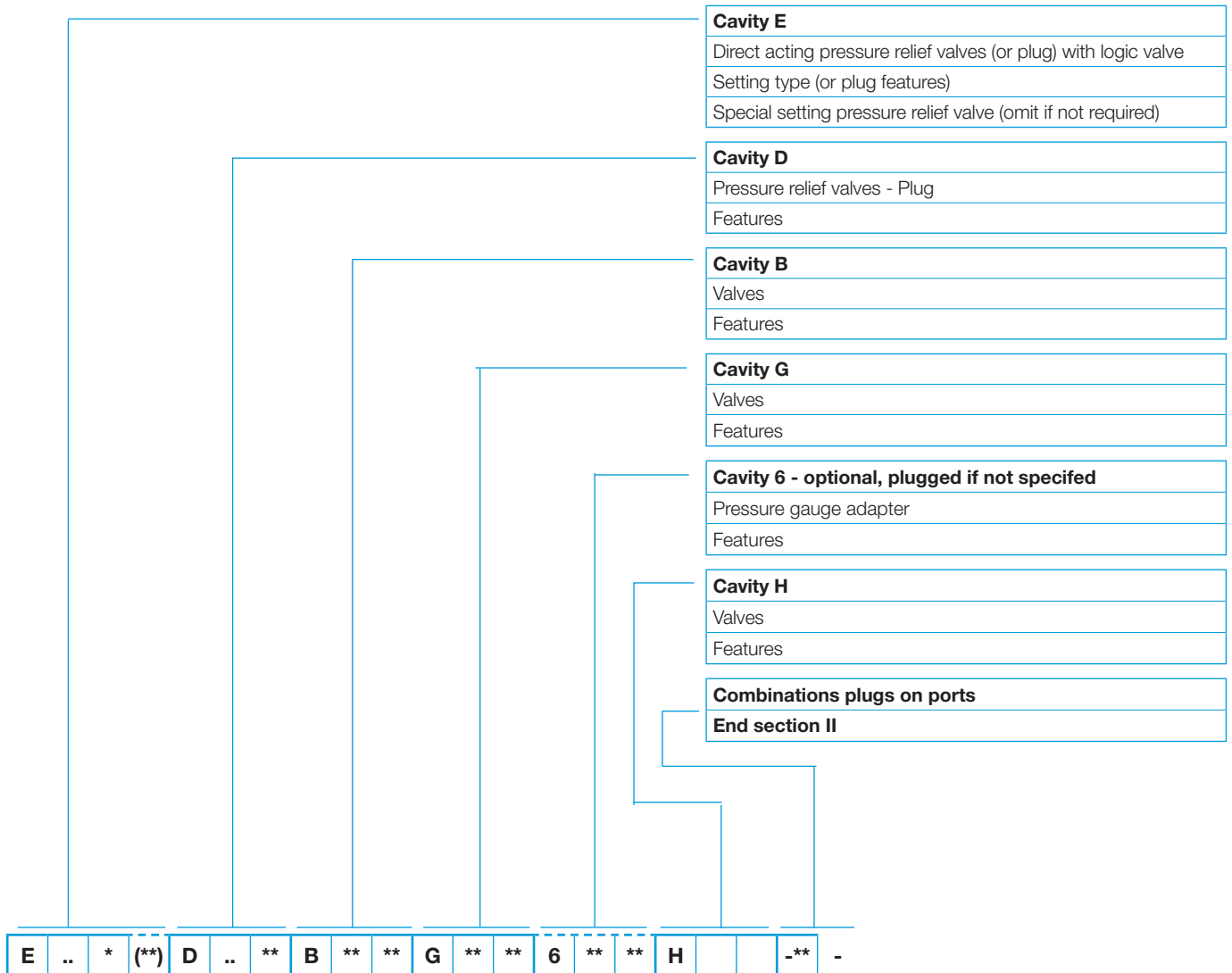

Selection code

6

SECTION III - PUMPS

i

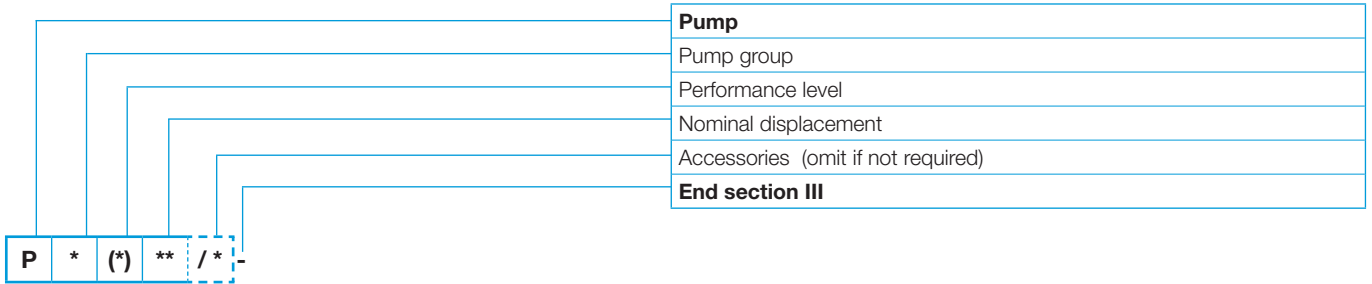

SECTION IV - TANKS / SECTION V - TUBES KIT

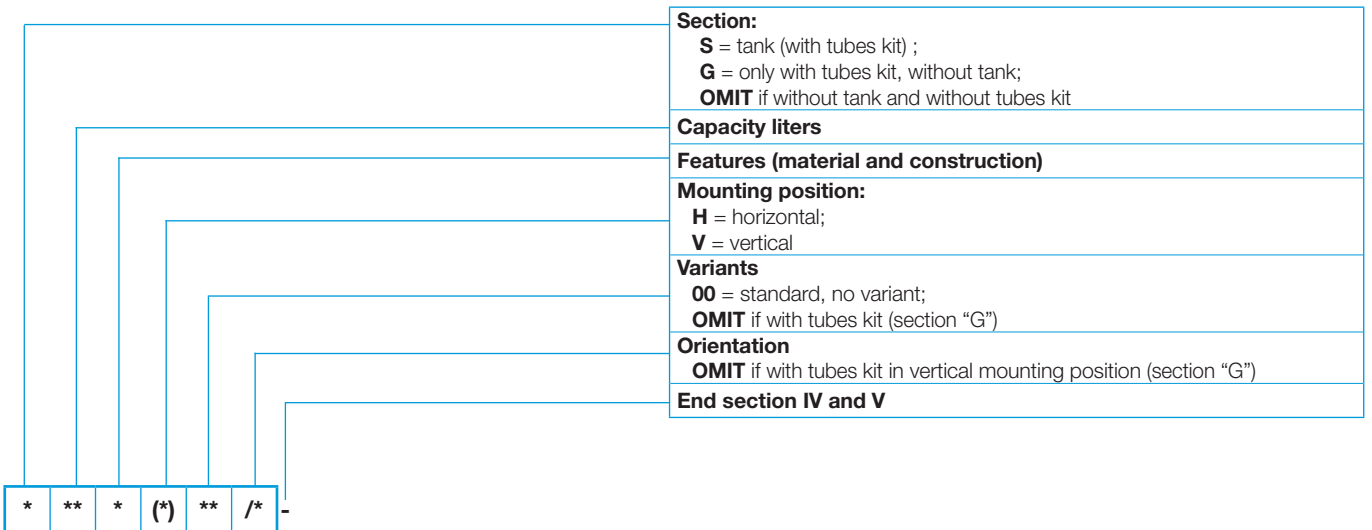

SECTION VI - MOTORS

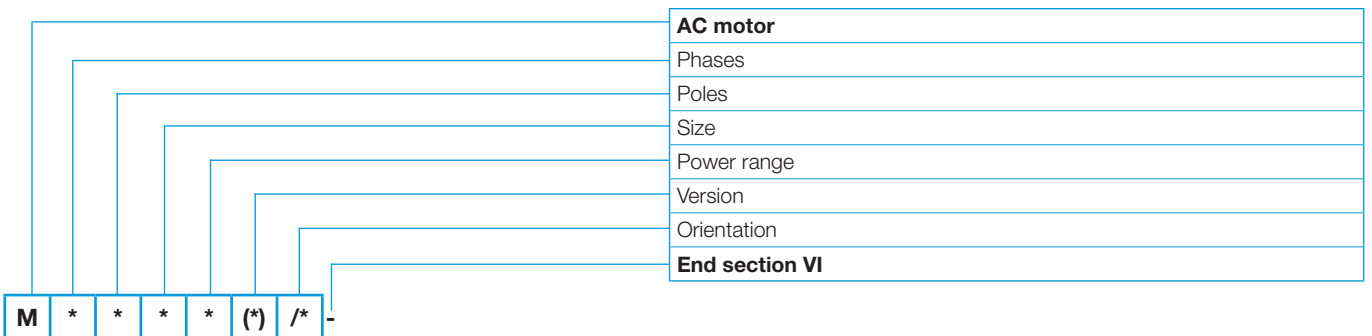



SECTION VII - TRANSMISSION KIT (only for motors on the catalog)

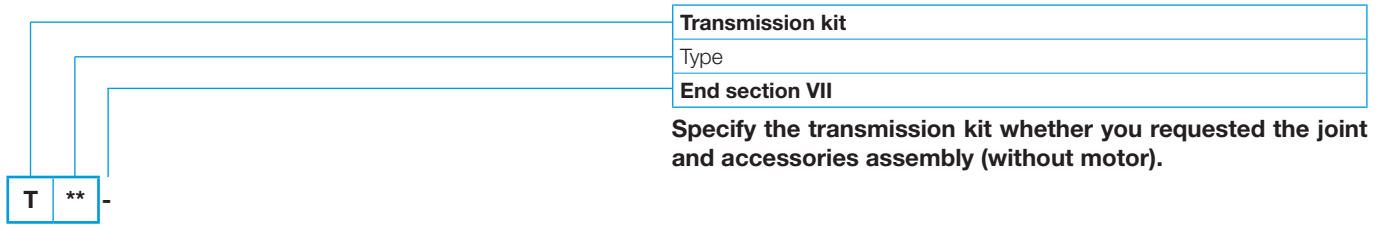

SECTION VIII - ACCESSORIES

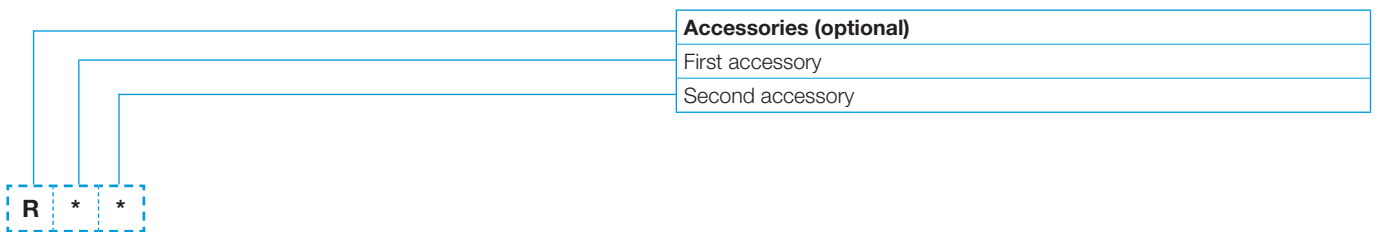

Endhead overall dimensions



Cavities on endhead:

Cavity		Thread
X-L	Ports	G1/4"
P-C-A	Ports	G3/8"
E	Peripheral	M20 x 1.5
D-B-G-H	Peripheral	3/4" 16 UNF
Y	Peripheral	M10 x 1
6	Peripheral pressure gauge	G1/8" STD plugged
K	Return	G1/2"
Q	Return	G1/4"
7-8	Return	Ø 8 not thread
W	Return	Ø 10 not thread

There are three types of cavities:

- Peripheral cavities, which can be accessed externally
- Return cavities, inside of the tank.
- Ports

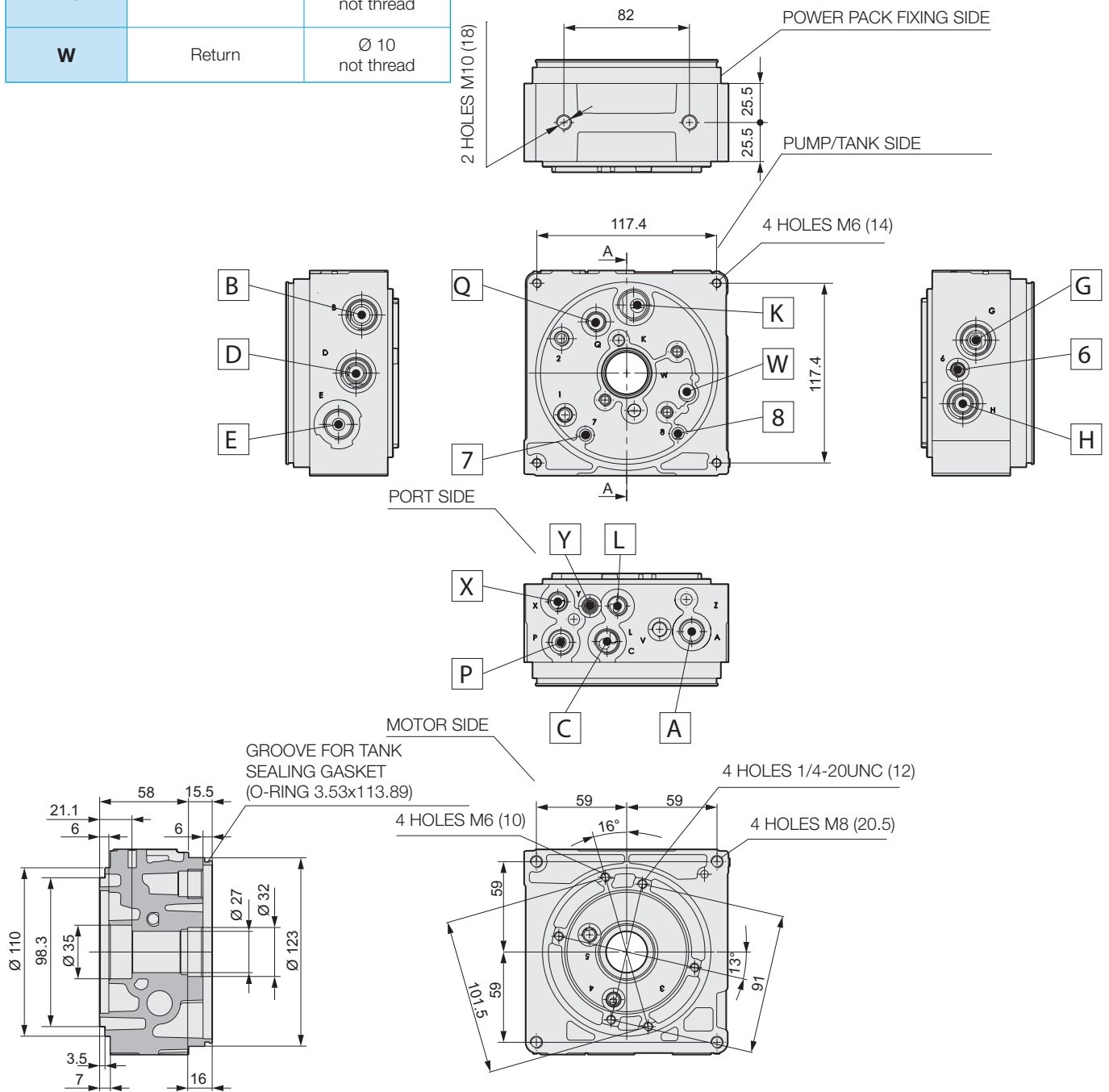

In the drawing are shown the common dimensions.



	Cavity	Thread	Drawing
E	Peripheral	M20 x 1.5	<p style="text-align: right;">CN044003</p>
D B G H	Peripheral	3/4" 16 UNF	<p style="text-align: right;">CD018014</p>
Y	Peripheral	M10 x 1	<p style="text-align: right;">CN019006</p>

Section I - Endhead choice

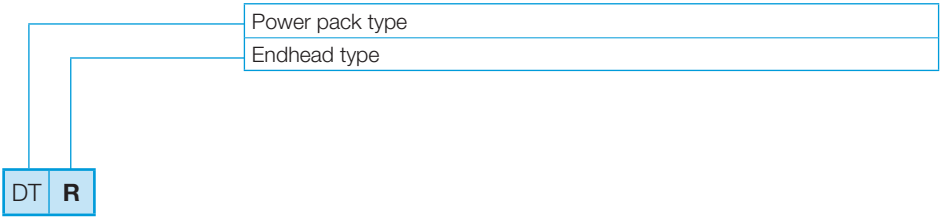

*** Endhead type**

* Cavity	Type	Thread
X-L	Ports	G1/4"
P-C-A	Ports	G3/8"
E	Peripheral	M20 x 1.5
D-B-G-H	Peripheral	3/4" 16 UNF
6	Peripheral pressure gauge	G1/8" STD plugged
K	Return	G1/2"

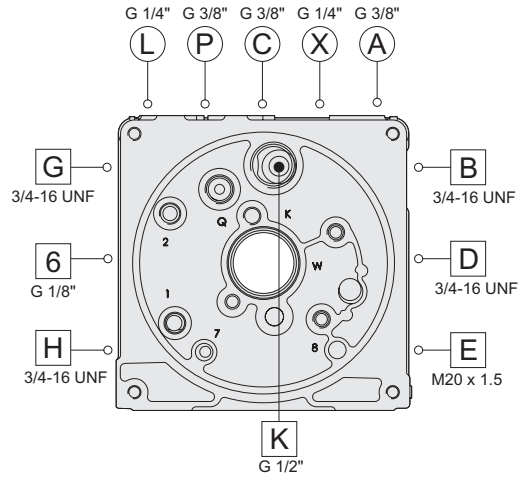

Endhead code
M17190001.000

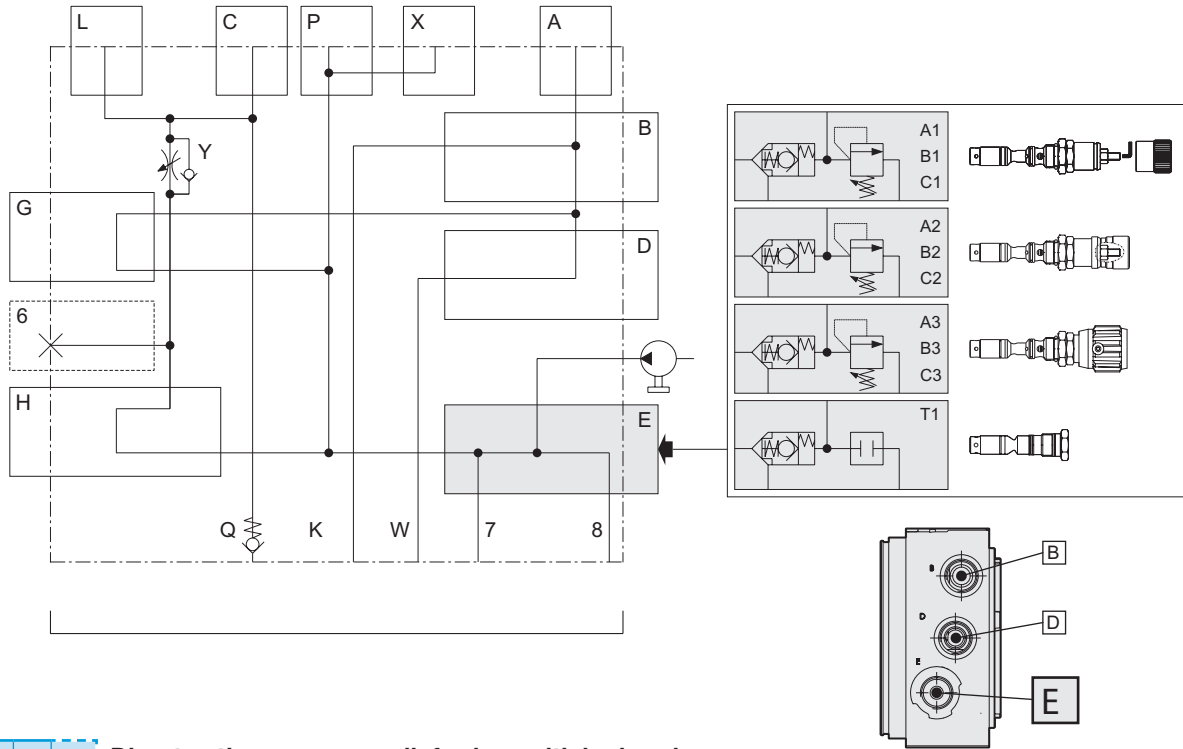
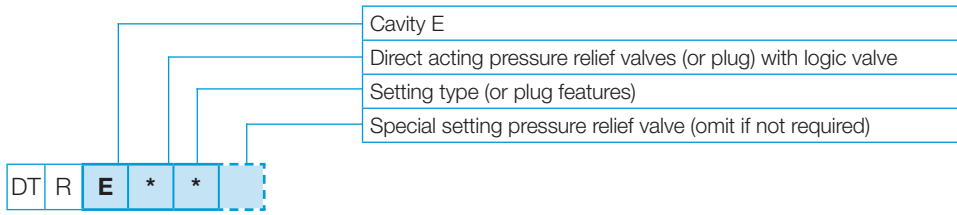

E * * (...) Direct acting pressure relief valves with logic valve

* *	Pressure (bar)	STD setting (bar)	(...) Special setting (bar)	Setting type	Code	Symbol	Drawing
A	15 ÷ 50	30	15 ÷ 50 (5 to 5)	Detachable closing	CPMK04S0001		
				Non removable closing (1)	CPMK04P0001		
				Plastic knob	CPMK04M0001		
B	35 ÷ 110	50	35 ÷ 110 (5 to 5)	Detachable closing	CPMK04S1001		
				Non removable closing (1)	CPMK04P1001		
				Plastic knob	CPMK04M1001		
C	75 ÷ 220	150	75 ÷ 220 (5 to 5)	Detachable closing	CPMK04S2001		
				Non removable closing (1)	CPMK04P2001		
				Plastic knob	CPMK04M2001		

1 = Supplied assembled. Unassembled, see accessories page 33

E * * Plug with logic valve

* *	Description	Code	Symbol	Drawing
T 1	Plug to replace pressure relief valve	27000026.000		

Section II - DTR Cavity D

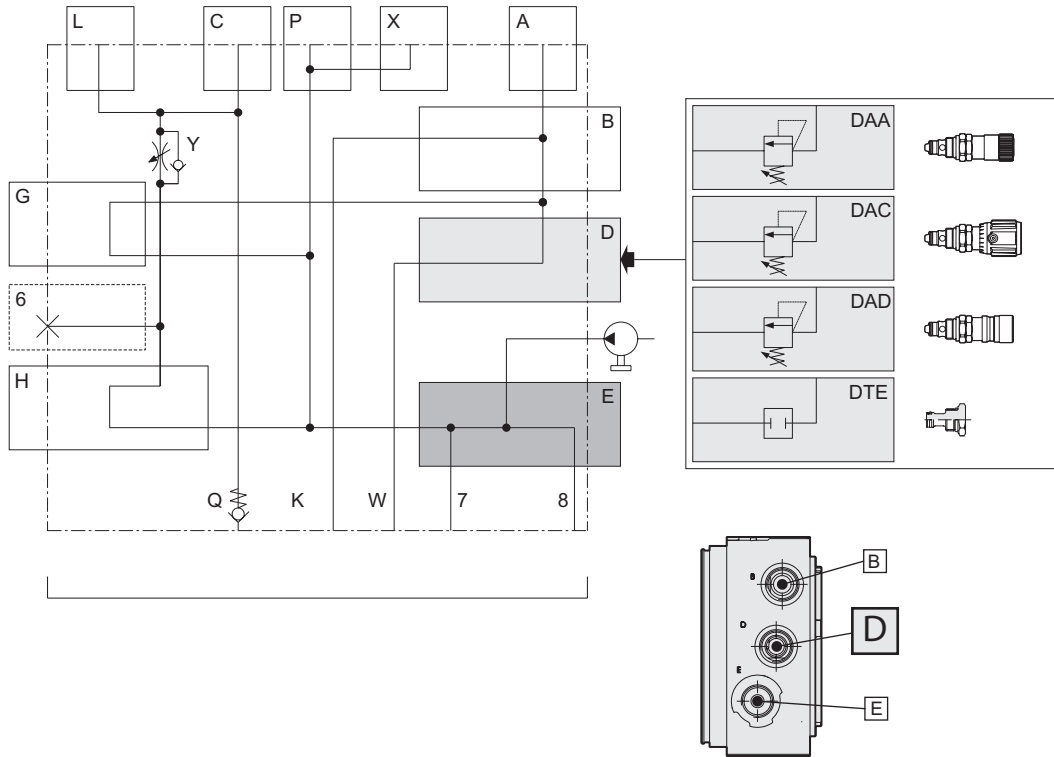
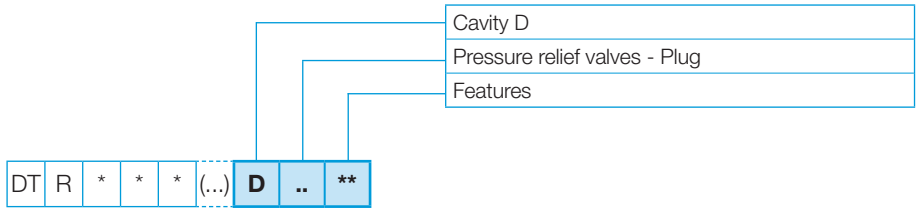

D A ** (...) Pressure relief valves

**	Description	(...) Special setting (bar)	Code	Symbol	Drawing
AD	Short screw adjustment + detachable closing	Min 15 - Max 50	CMP04AS0002		
AE		Min 35 - Max 110	CMP04AS1002		
AF		Min 75 - Max 220	CMP04AS2002		
AG	Min 160 - Max 290	CMP04AS3002			
CD	Plastic knob adjustment	Min 15 - Max 50			CMP04AM0002
CE		Min 35 - Max 110			CMP04AM1002
CF		Min 75 - Max 220	CMP04AM2002		
CG	Min 160 - Max 290	CMP04AM3002			
DD	Short screw + sealed cap	Min 15 - Max 50		CMP04AP0002	
DE		Min 35 - Max 110		CMP04AP1002	
DF		Min 75 - Max 220		CMP04AP2002	
DG		Min 160 - Max 290	CMP04AP3002		

D T * Plug

*	Description	Code	Symbol	Drawing
E	Long plug 3/4 16 UNF	20003800		



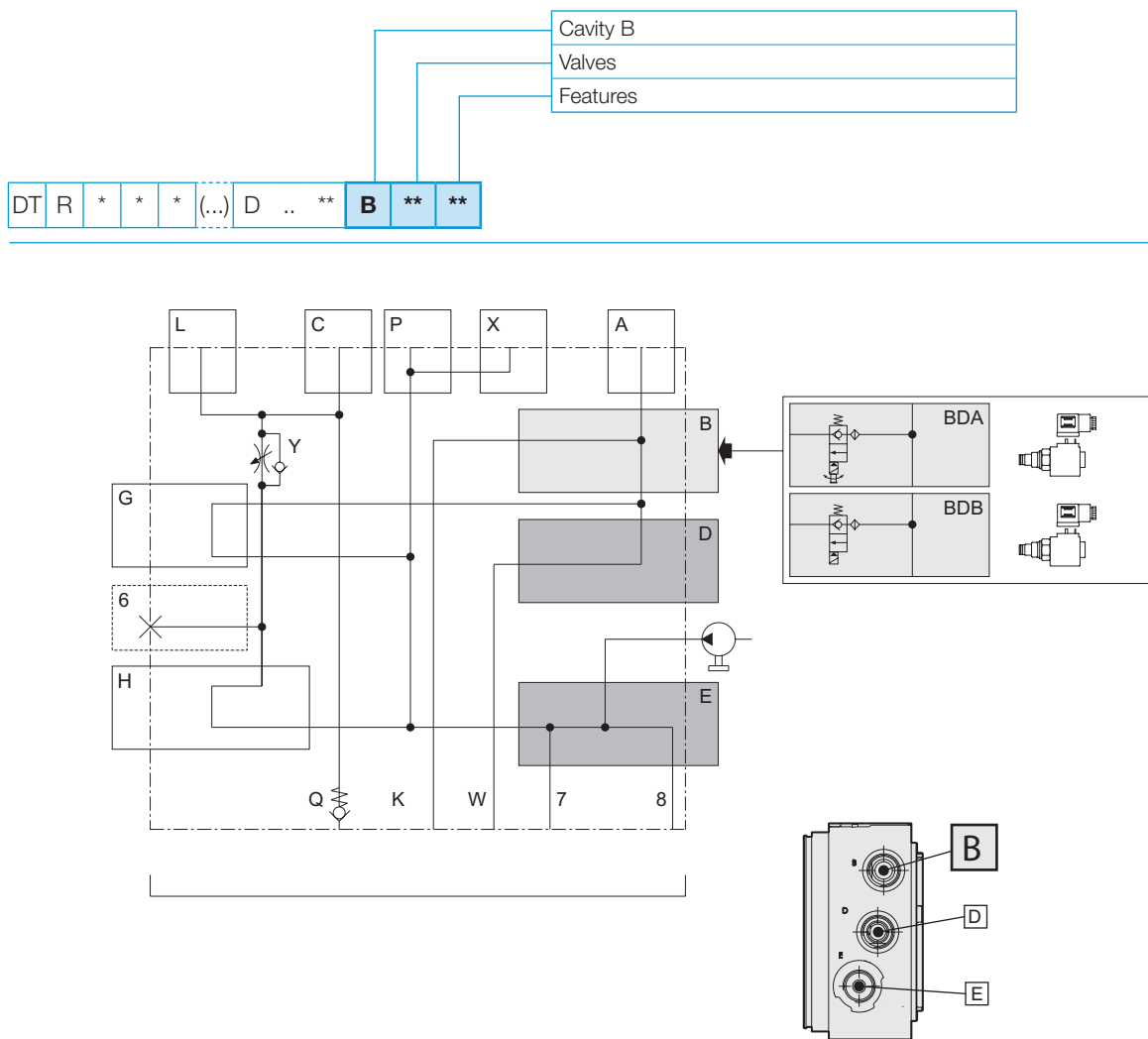

B DA ** Piloted solenoid valves normally closed, without emergency (1)

**	Description	Code (valve + connector)	Symbol	Drawing
AA	Voltage 12 Vdc	CRP0418NCASL003 + V86050002		
AB	Voltage 24 Vdc	CRP0418NCASM003 + V86050002		

B DB ** Piloted solenoid valves normally closed, with rotary emergency (1)

**	Description	Code (valve + connector)	Symbol	Drawing
AA	Voltage 12 Vdc	CRP0418NCAEL003 + V8605002		
AB	Voltage 24 Vdc	CRP0418NCAEM003 + V86050002		

1 = Valves supplied with connector. Without connector see accessories page 33

Section II - DTR Cavity G

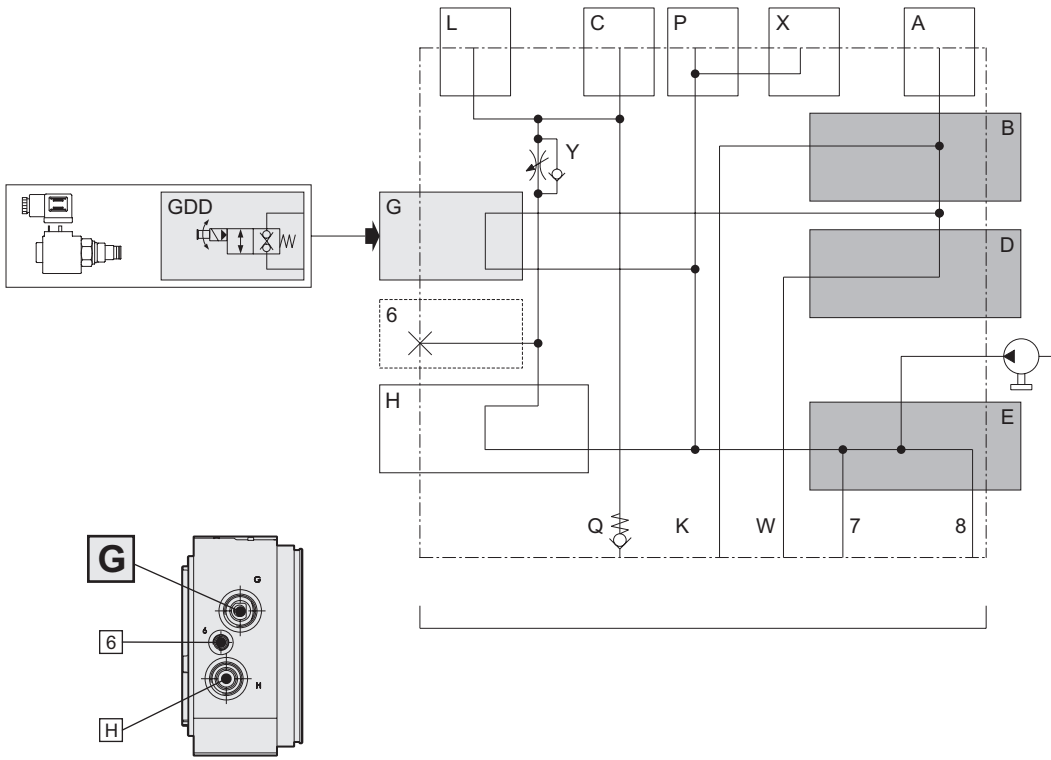
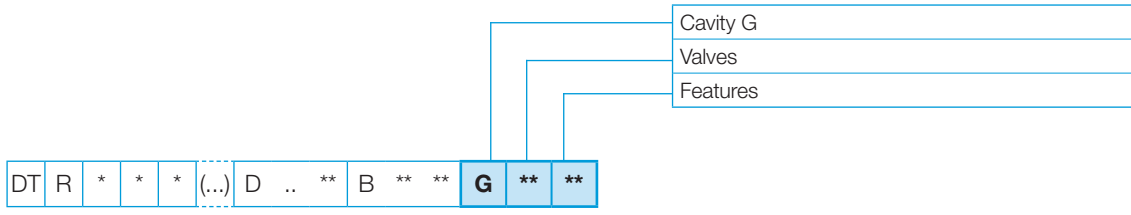

G DD ** Direct operated solenoid valve normally closed, with button emergency (1)

**	Description	Code (valve + connector)	Symbol	Drawing
AA	Voltage 12 Vdc	CRD0418NCAEL002 + V86050002		
AB	Voltage 24 Vdc	CRD0418NCAEM002 + V86050002		

1 = Valves supplied with connector. Without connector see accessories page 33

Section II - DTR Cavity 6 (optional)

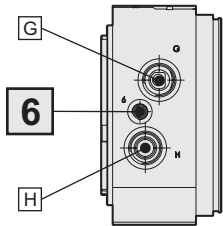
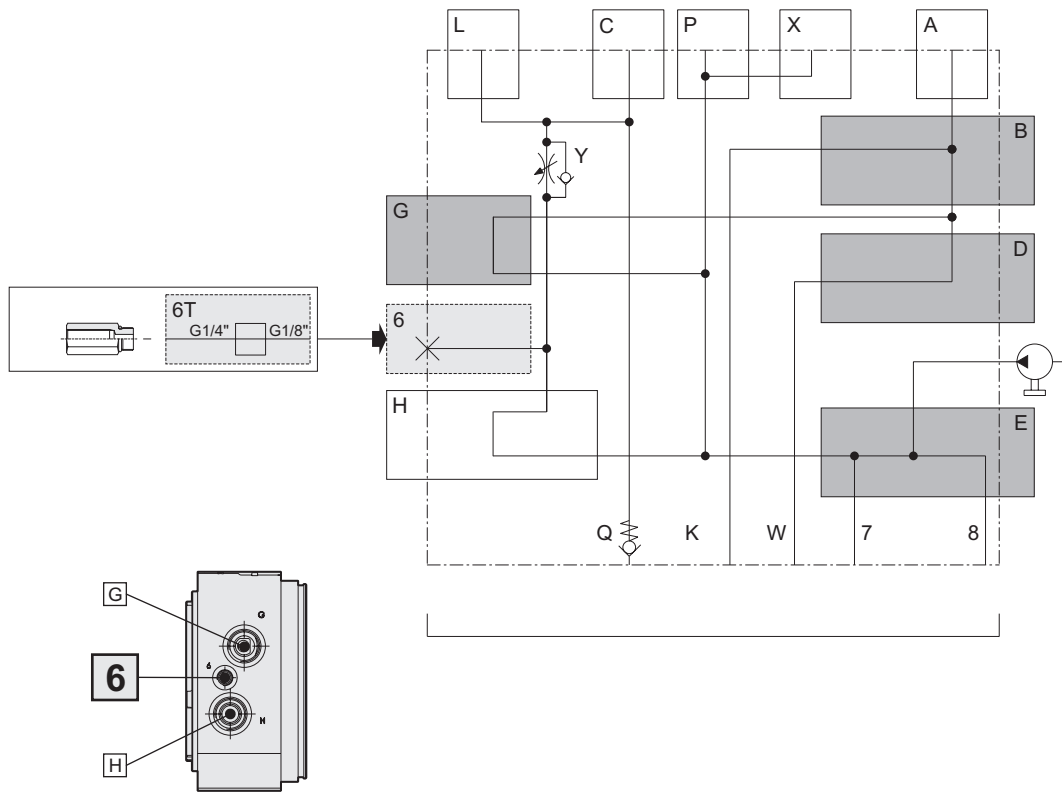
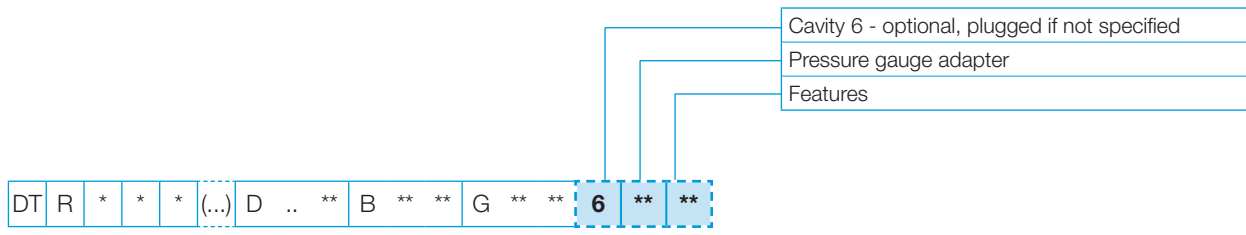

6 T * Pressure gauge adapter

*	Description	Code	Symbol	Drawing
M	Pressure gauge adapter G1/4" (male G1/8")	1321820		

Cavity H
Valves
Features

DT R * * * (...) D .. ** B ** ** G ** ** 6 ** ** H ** ** **

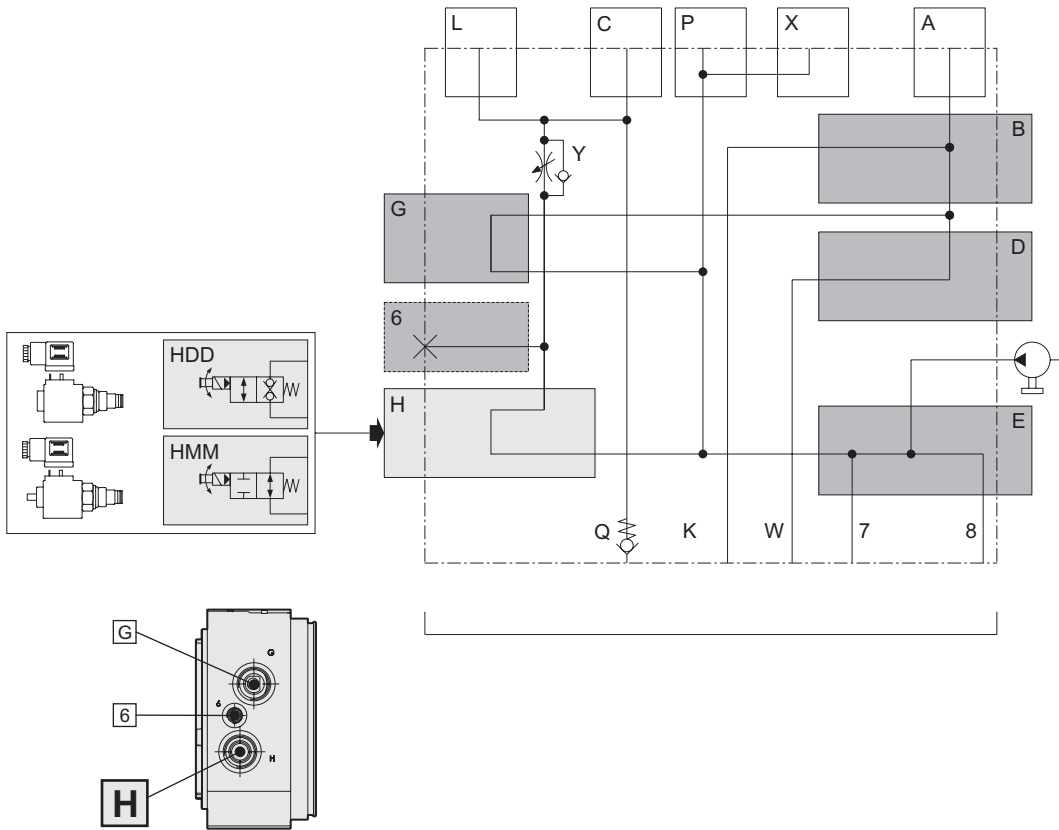

H DD ** Direct operated solenoid valve normally closed, with button emergency (1)

**	Description	Code (valve + connector)	Symbol	Drawing
AA	Voltage 12 Vdc	CRD0418NCAEL002 + V86050002		
AB	Voltage 24 Vdc	CRD0418NCAEM002 + V86050002		

H MM ** Direct operated solenoid valve normally opened, with button emergency (1)

**	Description	Code (valve + connector)	Symbol	Drawing
AA	Voltage 12 Vdc	C2V0422NAAEL002 + V86050002		
AB	Voltage 24 Vdc	CRD0418NCAEM002 + V86050002		

1 = Valves supplied with connector. Without connector see accessories page 33

Combinations plugs on ports
End section II

DT R * * * (...) D .. ** B ** ** G ** ** 6 ** ** H ** ** -**

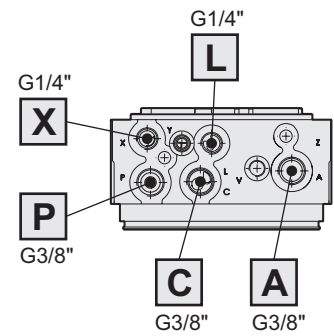
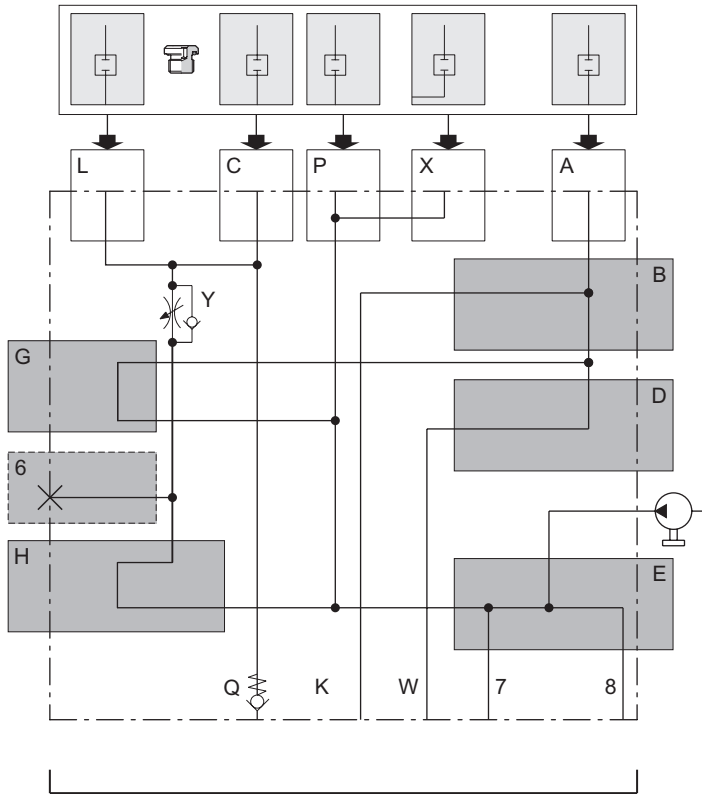

-** Plugs combinations

-**	A	P	C	X	L
-00	↑	↑	↑	⊗	⊗
-01	↑	⊗	⊗	↑	↑
-02	↑	⊗	↑	↑	⊗
-03	↑	⊗	↑	↑	↑

Symbols description

Type	Description	Thread	Code	Symbol	Drawing
⊗	Port closed with plug	G 1/4"	20024000		
		G 3/8"	Q26630006		
↑	Port open		-	-	-

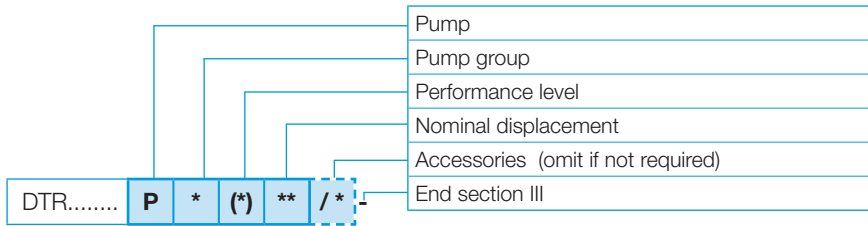

P 1 (2) ** Pumps group 1 with vent valve - Performance level 2

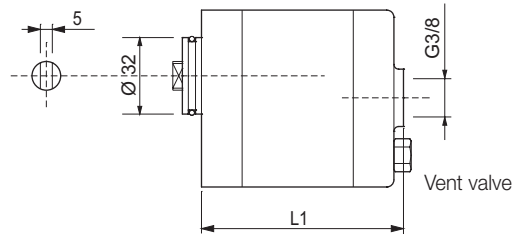

**	Nominal displacement	Tolerance on geometric displacement	P2 bar	P3 bar	Code complete kit	L1 mm
09	0.90 cc	0.83 ÷ 0.95	210	250	17050088.014	42.2
12	1.20 cc	1.10 ÷ 1.30	210	250	17050005.014	43.5
17	1.70 cc	1.50 ÷ 1.70	210	250	17050006.014	45.3
22	2.20 cc	2.10 ÷ 2.30	210	250	17050007.014	49.2
26	2.60 cc	2.50 ÷ 2.70	210	250	17050008.014	50.7
32	3.20 cc	3.10 ÷ 3.32	210	250	17050009.014	60.9
38	3.80 cc	3.60 ÷ 3.99	210	250	17050010.014	63.1
43	4.30 cc	4.00 ÷ 4,35	210	250	17050011.014	63.4

P2 = Intermittent operating pressure
 P3 = Intermittent peak pressure (20 sec. max)

P 1 (2) ** / * Pumps group 1 arranged for the start valve - Performance level 2 (1)

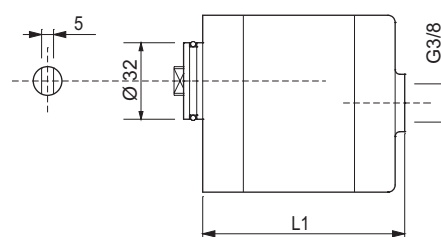

**	Nominal displacement	Tolerance on geometric displacement	P2 bar	P3 bar	Code complete kit	L1 mm
09	0.90 cc	0.83 ÷ 0.95	210	250	17050096.014	42.2
12	1.20 cc	1.10 ÷ 1.30	210	250	17050041.014	43.5
17	1.70 cc	1.50 ÷ 1.70	210	250	17050042.014	45.3
22	2.20 cc	2.10 ÷ 2.30	210	250	17050043.014	49.2
26	2.60 cc	2.50 ÷ 2.70	210	250	17050044.014	50.7
32	3.20 cc	3.10 ÷ 3.32	210	250	17050045.014	60.9
38	3.80 cc	3.60 ÷ 3.99	210	250	17050046.014	63.1
43	4.30 cc	4.00 ÷ 4,35	210	250	17050047.014	63.4

1 = Specify Accessory (see table below "Accessories for pumps group 1")
 P2 = Intermittent operating pressure
 P3 = Intermittent peak pressure (20 sec. max)

P 1 (1) ** / * Accessories for pumps group 1

*	Description	Type	Code	Symbol
/A	Single-phase motor start valve - on auxiliary outlet	0.8 ÷ 2.5 l/min	VAM0400L	
/B		> 2.5 ÷ 8.0 l/min	VAM0400M	
/C		> 8.0 ÷ 14 l/min	VAM0400H	
/D	Soft start valve - on auxiliary outlet	hole Ø 0.4 mm	VAMS0404001	

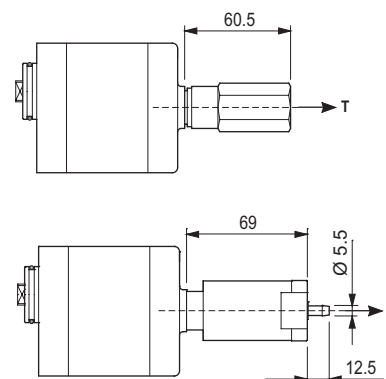

Section IV - Tanks / Section V - Tubes kit

Tank (S = with tank and tubes kit; G = only tubes kit, without tank; OMIT if without tank and without tubes kit)
Capacity liters
Features (material and construction)
Mounting position: (H = horizontal; V = vertical)
Variants (00 = standard, no variant) - OMIT if with tubes kit
Orientation - OMIT if with tubes kit in vertical mounting position
End section IV and V

DTR... * ** * (*) ** /*

**	Liters	*	Dimensions (mm)	Material	(*) Mounting	** Variants	Page	* Orientation
02	1,5	G	∅ 130x140 - L 135	Polyethylene	(H)	00	24	/1(std) /2 /3 /4
					(V)	00		
03	2.5	G	∅ 130x140 - L 235	Polyethylene	(H)	00	24	
					(V)	00		
04	2.5	A	∅ 126 - L 235	Sheet steel	(H)	00-01-02	21	
					(V)	00		
04	4	G	∅ 130x140 - L 295	Polyethylene	(H)	00	24	
					(V)	00		
04	4	L	∅ 180 - L 210	Polyethylene	(H)	00	25	
					(V)	00		
05	5	C	∅ 200 - L 210	Sheet steel	(H)	00-01-02-03	22	
					(V)	00		
07	7	L	∅ 180 - L 310	Polyethylene	(H)	00	26	
					(V)	00		
08	8	C	∅ 200 - L 306	Sheet steel	(H)	00-03	22	
					(V)	00		
10	10	C	∅ 200 - L 373	Sheet steel	(H)	00	22	
					(V)	00		
10	10	L	∅ 180 - L 410	Polyethylene	(H)	00	26	
					(V)	00		
12	12	D	∅ 260 - L 273	Sheet steel	(H)	00	23	
					(H)	01		
					(V)	00		

IV
V

Section IV - Tanks / Section V - Tubes kit

* ** * (H) ** * - Tanks Ø 126 - Sheet steel, capacity 2.5 liters - Horizontal mounting

Capacity	Features	Mounting	Variant (1)	L (mm)	Capacity (liters)			Tank (with plug)	Tank fixing kit (screws and O-Ring)
					Nominal	Full	Usable		
2.5	A	(H)	00	235	2.5	2.1	2	1321554	17010093

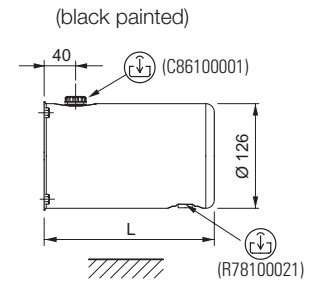

(1) Variant - OMIT if without tank but with tubes kit

(..) spare parts

Other variants

Variant				Tank	Variant				Tank	Variant				Tank
2.5	A	(H)	01	1321555	2.5	A	(H)	02	1321553					

--	--

IV
V

* ** * (V) ** * - Tanks Ø 126 - Sheet steel, capacity 2.5 - Vertical mounting

Capacity	Features	Mounting	Variant (1)	L (mm)	Capacity (liters)			Tank (with plug)	Tank fixing kit (screws and O-Ring)
					Nominal	Full	Usable		
2.5	A	(V)	00	235	2.5	2.1	2	1321764	17010093

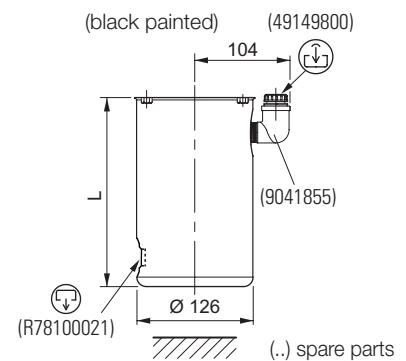

(1) Variant - OMIT if without tank but with tubes kit

(..) spare parts

Other variants

Variant		Tank	Variant		Tank	Variant		Tank	Variant		Tank

Section IV - Tanks / Section V - Tubes kit

* ** * (H) ** * - Tanks Ø 200 - Sheet steel, capacity 5-8 liters - Horizontal mounting

Capacity	Features	Mounting	Variant (1)	L (mm)	Capacity (liters)			Tank (with plug)	Tank fixing kit (screws and O-Ring)
					Nominal	Full	Usable		
05	C	(H)	00	210	5	5	4.7	1321546	17010093
08				306	8	8.0	7.7	1321539	

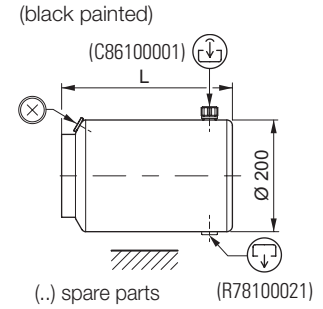

(1) Variant - OMIT if without tank but with tubes kit

Other variants

Variant	Tank	Variant	Tank	Variant	Tank	Variant	Tank
05 B (H) 01	1321542	05 B (H) 02	1321544	05 B (H) (V) 03	1321545	08 B (H) 01	1321538

* ** * (V) ** * - Tanks Ø 200 - Sheet steel, capacity 5-8 liters - Vertical mounting

Capacity	Features	Mounting	Variant (1)	L (mm)	Capacity (liters)			Tank (with plug)	Tank fixing kit (screws and O-Ring)
					Nominal	Full	Usable		
05	C	(V)	00	210	5	4.6	4.3	1321543	17010093
08				306	8	7.5	7.1	1321539	

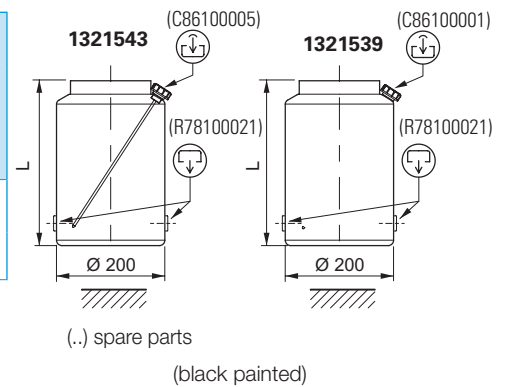

(1) Variant - OMIT if without tank but with tubes kit

Other variants

Variant	Tank	Variant	Tank	Variant	Tank	Variant	Tank

Section IV - Tanks / Section V - Tubes kit

* ** * (H) ** * - Tanks Ø 200 and Ø 260 - Sheet steel, capacity 12 liters - Horizontal mounting

Capacity	Features	Mounting	Variant (1)	L (mm)	Capacity (liters)			Tank (with plug)	Tank fixing kit (screws and O-Ring)
					Nominal	Full	Usable		
12	D	(H)	00	273	12	10	9.6	1321508	17010093
12	D	(H)	01	440	12	10	9.6	1321534	

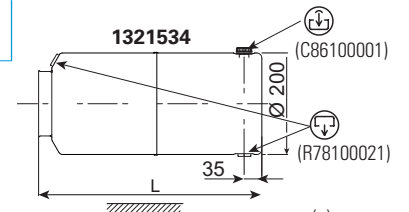
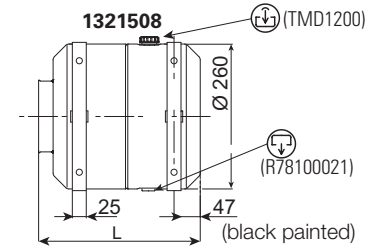

(1) Variant - OMIT if without tank but with tubes kit

Other variants

Variant	Tank	Variant	Tank	Variant	Tank	Variant	Tank

IV
V

* ** * (V) ** * - Tanks Ø 200 - Sheet steel, capacity 12 liters - Vertical mounting

Capacity	Features	Mounting	Variant (1)	L (mm)	Capacity (liters)			Tank (with plug)	Tank fixing kit (screws and O-Ring)
					Nominal	Full	Usable		
12	D	(V)	00	440	12	10	9.6	1321534	17010093

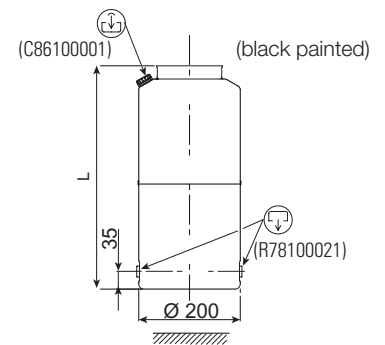

(1) Variant - OMIT if without tank but with tubes kit

(..) spare parts

Other variants

Variant	Tank	Variant	Tank	Variant	Tank	Variant	Tank

* ** * (H) ** * - Square polyethylene tanks capacity 4 liters - Horizontal mounting

Capacity	Features	Mounting	Variant (1)	L (mm)	Capacity (liters)			Tank (with plug, clamp, nuts)	Tank fixing kit Ø123 (screws and O-Ring)
					Nominal	Full	Usable		
04	L	(H)	00	210	4	3.6	3	1321547	17010087

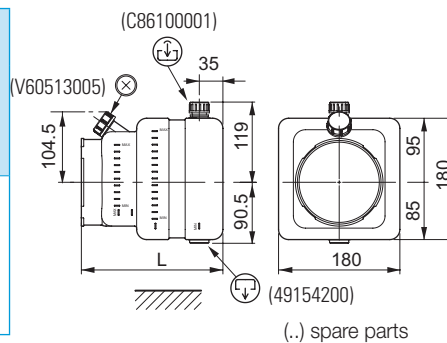

Operating temperature -10°C ÷ +70°C - (1) Variant - OMIT if without tank but with tubes kit

Other variants

Variant	Tank	Variant	Tank	Variant	Tank	Variant	Tank

IV
V

* ** * (V) ** * - Square polyethylene tanks capacity 4 liters - Vertical mounting

Capacity	Features	Mounting	Variant (1)	L (mm)	Capacity (liters)			Tank (with plug, clamp, nuts)	Tank fixing kit Ø123 (screws and O-Ring)
					Nominal	Full	Usable		
04	L	(V)	00	210	4	3.7	3	1321548	17010087

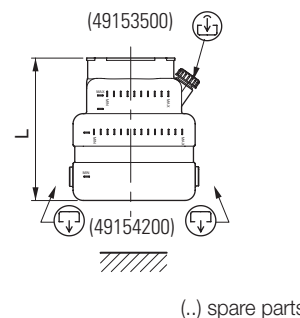

Operating temperature -10°C ÷ +70°C - (1) Variant - OMIT if without tank but with tubes kit

Other variants

Variant	Tank	Variant	Tank	Variant	Tank	Variant	Tank

* ** * (H) ** * - Square polyethylene tanks capacity 7-10 liters - Horizontal mounting

Capacity	Features	Mounting	Variant (1)	L (mm)	Capacity (liters)			Tank (with plug, clamp, nuts)	Tank fixing kit Ø123 (screws and O-Ring)
					Nominal	Full	Usable		
07	L	(H)	00	310	7	6.7	5.5	1321541	17010087
10				410	10	8.7	7.5	1321537	

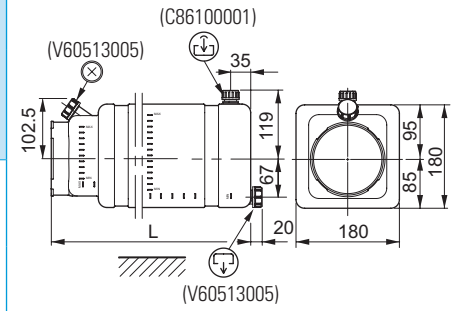

(..) spare parts

Operating temperature -10°C ÷ +70°C - (1) Variant - OMIT if without tank but with tubes kit

IV
V

* ** * (V) ** * - Square polyethylene tanks capacity 7-10 liters - Vertical mounting

Capacity	Features	Mounting	Variant (1)	L (mm)	Capacity (liters)			Tank (with plug, clamp, nuts)	Tank fixing kit Ø123 (screws and O-Ring)
					Nominal	Full	Usable		
07	L	(V)	00	310	7	6.7	6	1321540	17010087
10				410	10	9.8	9	1321535	

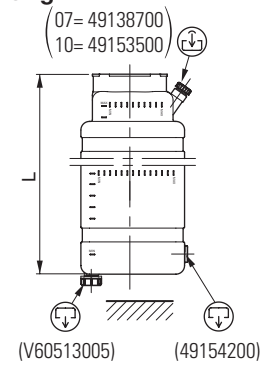

(..) spare parts

Operating temperature -10°C ÷ +70°C - (1) Variant - OMIT if without tank but with tubes kit

* ** * (*) ** /* - Tanks orientation according to the mounting position

For tanks			(*)	Mounting position	/* Orientation			
S	**	A C D	(H)	Horizontal	/1 (standard)	/2	/3	/4
					(1)			

For tanks			(*)	Mounting position	/* Orientation			
S	12	D	(H)	Horizontal	/1 (standard)	/2	/3	/4

For tanks			(*)	Mounting position	/* Orientation			
S	**	G L	(H)	Horizontal	/1 (standard)	/2	/3	/4
					(1)			

For tanks			(*)	Mounting position	/* Orientation			
S	**	A C D G L	(V)	Vertical	/1 (standard)	/2	/3	/4
					(2)			

(1) Orientation TO BE USED with blocks

Section VI - AC Motors

Motor
Phases
Poles
Size
Power range
Version
Orientation
End section VI

DTR **M** * * * * (*) /* -

VI

* Phases	* Poles	* Size	* Power range		Page	(*) Version	/* Orientation					
			Power	Voltage								
M	Single-phase	2	L 71	A	0.37 kW	230 Vac 50 Hz	29	(1) Std	/1 /2 /3 /4 Std			
			L 71	B	0.55 kW	230 Vac 50 Hz	29					
			S 71	A	0.75 kW	230 Vac 50 Hz	31					
			S 71	B	1.10 kW	230 Vac 50 Hz	34					
			M 80	A	0.75 kW	230 Vac 50 Hz	29					
			M 80	B	1.10 kW	230 Vac 50 Hz	29					
			N 90	A	1.50 kW	230 Vac 50 Hz	29					
			N 90	B	2.20 kW	230 Vac 50 Hz	29					
			P 100	A	3.00 kW	230 Vac 50 Hz	29					
		4	L 71	A	0.25 kW	230 Vac 50 Hz	29					
			L 71	B	0.37 kW	230 Vac 50 Hz	29					
			M 80	A	0.55 kW	230 Vac 50 Hz	29					
			M 80	B	0.75 kW	230 Vac 50 Hz	29					
			N 90	A	1.10 kW	230 Vac 50 Hz	29					
			N 90	B	1.50 kW	230 Vac 50 Hz	29					
			P 100	A	2.20 kW	230 Vac 50 Hz	29					
			T	Three-phase	2	R 63	A			0.18 kW	230/400 Vac 50 Hz	30
						R 63	B			0.25 kW	230/400 Vac 50 Hz	30
L 71	A	0.37 kW				230/400 Vac 50 Hz	30					
L 71	B	0.55 kW				230/400 Vac 50 Hz	30					
S 71	A	0.75 kW				230/400 Vac 50 Hz	31					
M 80	A	0.75 kW				230/400 Vac 50 Hz	30					
M 80	B	1.10 kW				230/400 Vac 50 Hz	30					
N 90	A	1.50 kW				230/400 Vac 50 Hz	30					
N 90	B	2.20 kW				230/400 Vac 50 Hz	30					
P 100	A	3.00 kW			230/400 Vac 50 Hz	30						
P 112	B	4.00 kW			230/400 Vac 50 Hz	30						
4	R 63	A			0.12 kW	230/400 Vac 50 Hz	30					
	R 63	B			0.18 kW	230/400 Vac 50 Hz	30					
	L 71	A			0.25 kW	230/400 Vac 50 Hz	30					
	L 71	B			0.37 kW	230/400 Vac 50 Hz	30					
	S 71	A			0.75 kW	230/400 Vac 50 Hz	31					
	M 80	A			0.55 kW	230/400 Vac 50 Hz	30					
	M 80	B			0.75 kW	230/400 Vac 50 Hz	30					
	N 90	A	1.10 kW	230/400 Vac 50 Hz	30							
	N 90	B	1.50 kW	230/400 Vac 50 Hz	30							
P 100	A	2.20 kW	230/400 Vac 50 Hz	30								
P 100	B	3.00 kW	230/400 Vac 50 Hz	30								
P 112	C	4.00 kW	230/400 Vac 50 Hz	30								

Motors supplied with all assembly components (transmission kit, coupling, etc).



M * * * * (*)

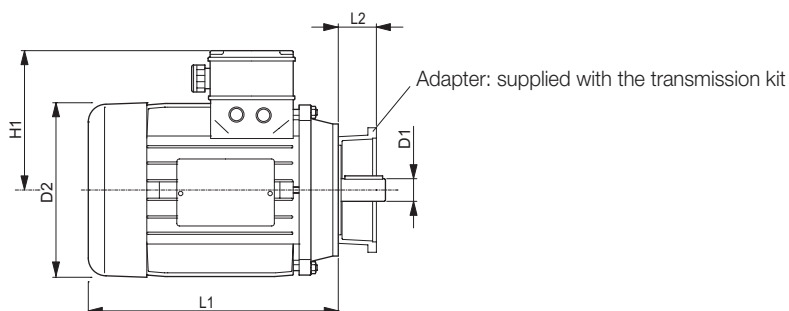

Single-phase motors 2-4 Poles - 230 Vac 50Hz - Version B14

M	*	*	*	*	(*)	Phases	Poles	Size	D1 (°)	D2 (°)	H1 (°)	L1 (°)	Power range					Cable gland metric thred	Adapter			Single Motor	Transmission kit (for pump)
													Po- wer kW	Voltage	IP	IC	S1		Code	Screw UNI 5931	L2		
M	M	2	L	A	(1)	2	2	71	14	148	115	208	0.37	230 Vac 50 Hz	54	F	Si	20-25	61000700	M6x20	19.5	9045596	KIT08019.012
M	M	2	L	B	(1)	2	2	71	14	148	115	208	0.55	230 Vac 50 Hz	54	F	Si	20-25	61000700	M6x20	19.5	9045597	
M	M	2	M	A	(1)	2	2	80	19	170	126	234	0.75	230 Vac 50 Hz	54	F	Si	20-25	61000800	M6x20	30.4	9045598	KIT08019.014
M	M	2	M	B	(1)	2	2	80	19	170	126	234	1.10	230 Vac 50 Hz	54	F	Si	20-25	61000800	M6x20	30.4	9045599	
M	M	2	N	A	(1)	2	2	90	24	185	142	247	1.50	230 Vac 50 Hz	54	F	Si	20-25	61000900	M8x21	40.4	9045600	KIT08019.016
M	M	2	N	B	(1)	2	2	90	24	185	142	272	2.20	230 Vac 50 Hz	54	F	Si	20-25	61000900	M8x21	40.4	9045601	
M	M	2	P	A	(1)	2	2	100	28	210	155	310	3.00	230 Vac 50 Hz	54	F	Si	25-32	61001000	M8x28	75	9045602	KIT08019.046
M	M	4	L	A	(1)	2	4	71	14	148	115	208	0.25	230 Vac 50 Hz	54	F	Si	20-25	61000700	M6x20	19.5	9045589	KIT08019.012
M	M	4	L	B	(1)	2	4	71	14	148	115	208	0.37	230 Vac 50 Hz	54	F	Si	20-25	61000700	M6x20	19.5	9045590	
M	M	4	M	A	(1)	2	4	80	19	170	126	234	0.55	230 Vac 50 Hz	54	F	Si	20-25	61000800	M6x20	30.4	9045591	KIT08019.014
M	M	4	M	B	(1)	2	4	80	19	170	126	234	0.75	230 Vac 50 Hz	54	F	Si	20-25	61000800	M6x20	30.4	9045592	
M	M	4	N	A	(1)	2	4	90	24	185	142	247	1.10	230 Vac 50 Hz	54	F	Si	20-25	61000900	M8x21	40.4	9045593	KIT08019.016
M	M	4	N	B	(1)	2	4	90	24	185	142	272	1.50	230 Vac 50 Hz	54	F	Si	20-25	61000900	M8x21	40.4	9045594	
M	M	4	P	A	(1)	2	4	100	28	210	155	310	2.20	230 Vac 50 Hz	54	F	Si	25-32	61001000	M8x28	75	9045595	KIT08019.046

VI



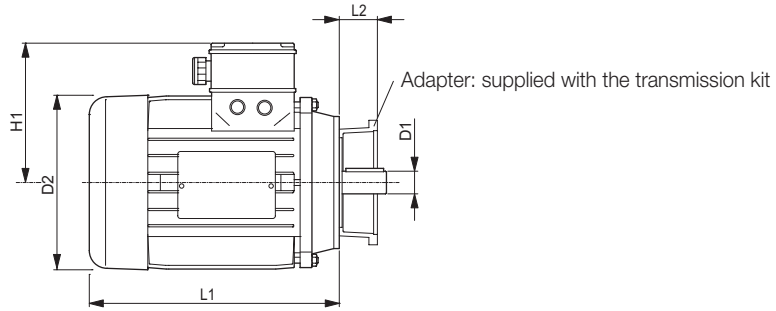

Three-phase motors 2-4 Poles - 230/400 Vac 50Hz - Version B14

M	T	Poles	Size	D1 (•)	D2 (•)	H1 (•)	L1 (•)	Power range				Cable gland metric thred	Adapter			Single Motor	Transmission kit (for pump)						
								Power kW	Voltage	IP	IC		S3	Code	Screw UNI 5931			L2					
M	T	2	R	A	(1)	3	2	63	11	125	95	189	0.18	230/400 Vac 50 Hz	54	F	60%	16-20	61004300	M5x16	19.5	9045557	KIT08019.010
M	T	2	R	B	(1)	3	2	63	11	125	95	189	0.25	230/400 Vac 50 Hz	54	F	60%	16-20	61004300	M5x16	19.5	9045558	
M	T	2	L	A	(1)	3	2	71	14	148	115	208	0.37	230/400 Vac 50 Hz	54	F	60%	20-25	61000700	M6x20	19.5	9045559	KIT08019.012
M	T	2	L	B	(1)	3	2	71	14	148	115	208	0.55	230/400 Vac 50 Hz	54	F	60%	20-25	61000700	M6x20	19.5	9045560	
M	T	2	M	A	(1)	3	2	80	19	170	126	234	0.75	230/400 Vac 50 Hz	54	F	60%	20-25	61000800	M6x20	30.4	9045527	KIT08019.014
M	T	2	M	B	(1)	3	2	80	19	170	126	234	1.10	230/400 Vac 50 Hz	54	F	60%	20-25	61000800	M6x20	30.4	9045561	
M	T	2	N	A	(1)	3	2	90	24	185	142	247	1.50	230/400 Vac 50 Hz	54	F	60%	20-25	61000900	M8x21	40.4	9045562	KIT08019.016
M	T	2	N	B	(1)	3	2	90	24	185	142	272	2.20	230/400 Vac 50 Hz	54	F	60%	20-25	61000900	M8x21	40.4	9045563	
M	T	2	P	A	(1)	3	2	100	28	210	155	310	3.00	230/400 Vac 50 Hz	54	F	60%	25-32	61001000	M8x28	75	9045564	KIT08019.046
M	T	2	P	B	(1)	3	2	112	28	225	182	325	4.00	230/400 Vac 50 Hz	54	F	60%	25-32	61001000	M8x28	75	9045565	
M	T	4	R	A	(1)	3	4	63	11	125	95	189	0.12	230/400 Vac 50 Hz	54	F	60%	16-20	61004300	M5x16	19.5	9045574	KIT08019.010
M	T	4	R	B	(1)	3	4	63	11	125	95	189	0.18	230/400 Vac 50 Hz	54	F	60%	16-20	61004300	M5x16	19.5	9045575	
M	T	4	L	A	(1)	3	4	71	14	148	115	208	0.25	230/400 Vac 50 Hz	54	F	60%	20-25	61000700	M6x20	19.5	9045576	KIT08019.012
M	T	4	L	B	(1)	3	4	71	14	148	115	208	0.37	230/400 Vac 50 Hz	54	F	60%	20-25	61000700	M6x20	19.5	9045577	
M	T	4	M	A	(1)	3	4	80	19	170	126	234	0.55	230/400 Vac 50 Hz	54	F	60%	20-25	61000800	M6x20	30.4	9045578	KIT08019.014
M	T	4	M	B	(1)	3	4	80	19	170	126	234	0.75	230/400 Vac 50 Hz	54	F	60%	20-25	61000800	M6x20	30.4	9045579	
M	T	4	N	A	(1)	3	4	90	24	185	142	247	1.10	230/400 Vac 50 Hz	54	F	60%	20-25	61000900	M8x21	40.4	9045580	KIT08019.016
M	T	4	N	B	(1)	3	4	90	24	185	142	272	1.50	230/400 Vac 50 Hz	54	F	60%	20-25	61000900	M8x21	40.4	9045581	
M	T	4	P	A	(1)	3	4	100	28	210	155	310	2.20	230/400 Vac 50 Hz	54	F	60%	25-32	61001000	M8x28	75	9045583	KIT08019.046
M	T	4	P	B	(1)	3	4	100	28	210	155	310	3.00	230/400 Vac 50 Hz	54	F	60%	25-32	61001000	M8x28	75	9045584	
M	T	4	P	C	(1)	3	4	112	28	225	182	325	4.00	230/400 Vac 50 Hz	54	F	60%	25-32	61001000	M8x28	75	9045585	

(•)= Approximate dimensions

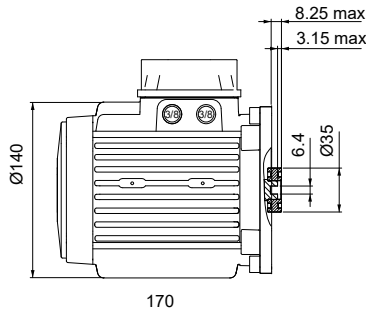

Three-phase motors 2-4 Poles - 230/400 Vac 50Hz - Direct fixing

Phases	Poles	Size	Power range				Cable gland metric thred	Single Motor	Transmission kit	Note							
			Power kW	Voltage	IP	IC					Service						
M	T	2	S	A	(1)	3	2	71	0.75	230/400 Vac 50 Hz	54	F	Light-duty	20	9044919	KIT09008.000	Without fan
M	T	2	S	B	(1)	3	2	71	1.10	230/400 Vac 50 Hz	54	F	Light-duty	20	9044406	KIT09008.000	Without fan
M	T	4	S	A	(1)	3	4	71	0.75	230/400 Vac 50 Hz	54	F	Light-duty	20	9044411	KIT09008.000	Without fan

IP protection level becomes effective after installation on power pack.

M * * * * (*) /* - Motor orientation

Connector box position on power pack.

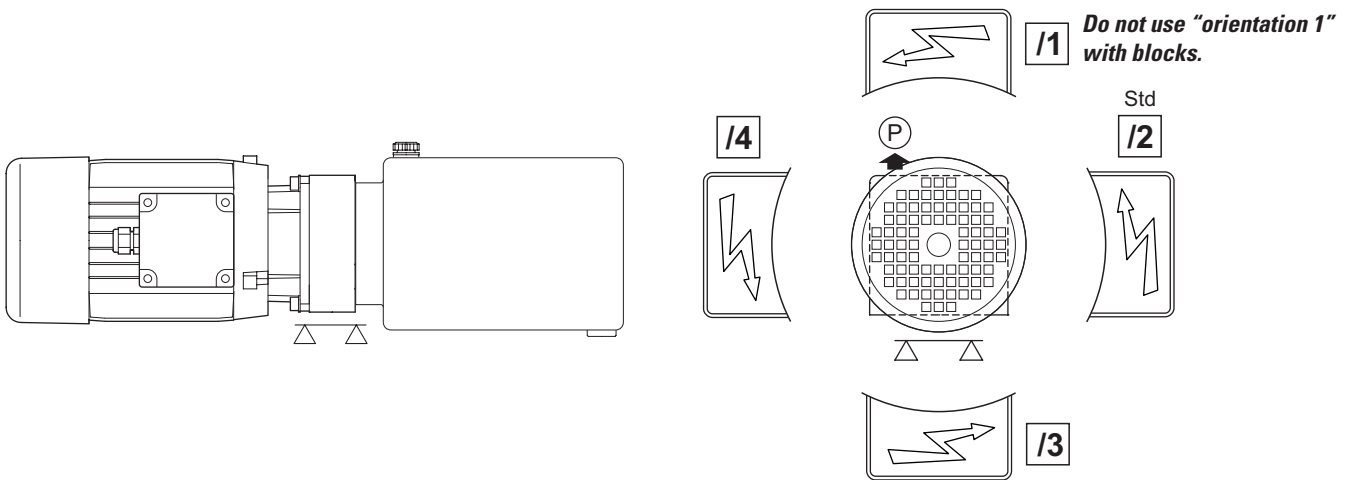

Section VII - Transmission kit AC motors

Transmission kit (only for motors on the catalog)
 Type
 End section VII

Specify the transmission kit whether you requested the joint and accessories assembly (without motor).

DTR..... **T** ****** -

**	Transmission kit						For AC motors		Page
	Code	Pump	L	Ø	L1	Z	Ref.	Size	
1R	KIT08019.010	Gr. 1	19.5	20	30	42.8	R	63 (B14)	29 30

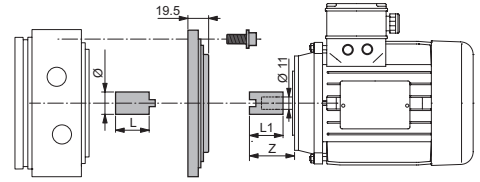

**	Transmission kit						For AC motors		Page
	Code	Pump	L	Ø	L1	Z	Ref.	Size	
1L	KIT08019.012	Gr. 1	19.5	20	26.5	42	L	71 (B14)	29 30

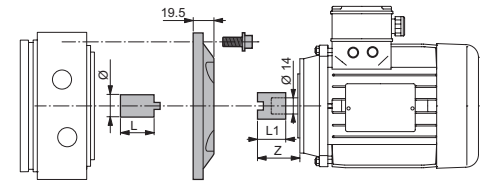

**	Transmission kit						For AC motors		Page
	Code	Pump	L	Ø	L1	Z	Ref.	Size	
1M	KIT08019.014	Gr. 1	19.5	20	38	53	M	80 (B14)	29 30

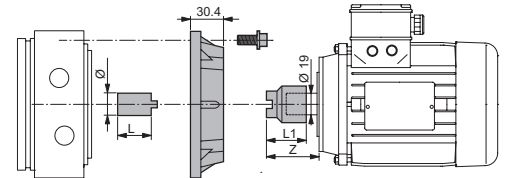

**	Transmission kit						For AC motors		Page
	Code	Pump	L	Ø	L1	Z	Ref.	Size	
1N	KIT08019.016	Gr. 1	19.5	20	45.5	63	N	90 (B14)	29 30

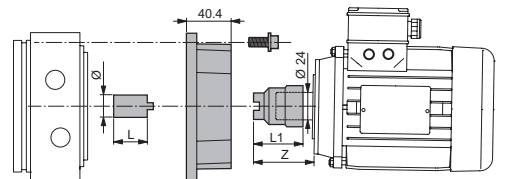

**	Transmission kit						For AC motors		Page
	Code	Pump	L	Ø	L1	Z	Ref.	Size	
1P	KIT08019.046	Gr. 1	36.3	20	57	81.5	P	100-112 (B14)	29 30

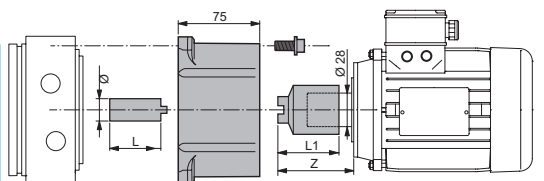

**	Transmission kit				For AC motors		Page
	Code	Pump	L	Ø	Ref.	Size	
1S	KIT09008.000	Gr. 1	37.9	14	S	71 (direct fixing)	31

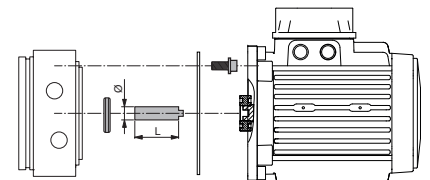



“Z” : dimension of the coupling side motor

Section VIII - Accessories (optional)

Accessories (optional)
First accessory
Second accessory

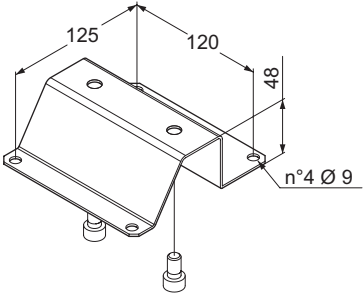
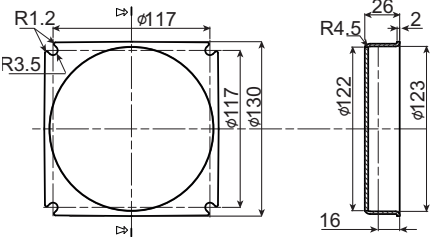
DTR **R * ***

*	Description	Drawing	Code	Note
B	Non-removable red plastic plug for pressure relief valve (unassembled)		Plug: 60309200	
D	High foot, (galvanized sheet steel) thickness 2 mm (unassembled)		Kit (foot and screws): 17010053	All motors are compatible except orientation / 3 Tanks compatible (except for orientation / 3) S**A S**B S**C S**D S**F S**G S**L
E	Collar in welded sheet steel, thickness 2 mm (unassembled)		Collar: F80000001 Tank fixing kit (screws and O-Ring): 17010093	
F	Without valves connectors			

Example with DTR endhead

DTR	EB1(100)	DAAF(100)	BDBAB	GDDAB	HDDAB	00
-----	----------	-----------	-------	-------	-------	----

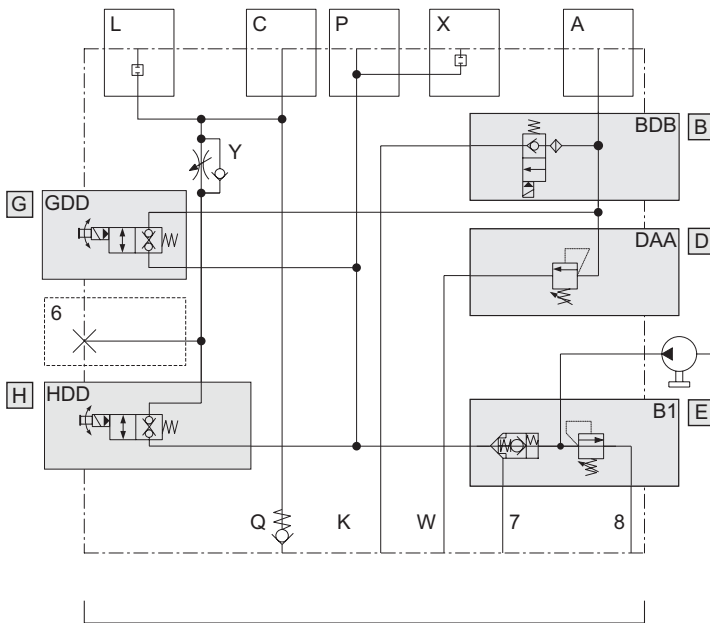

Cavity	Code	Description	Page
	R		10
E	EB1(100)	Pressure relief valve with logic valve (35 ÷ 110 bar) with screw and detachable closing, special setting 100 bar	11
D	DAAF(150)	Pressure relief valve with short screw adjustment and detachable closing, special setting 150 bar	12
B	BDBAB	Piloted solenoid valve normally closed, with rotary emergency. Voltage 24 VDC	13
G	GDDAB	Direct operated solenoid valve normally closed, with button emergency. Voltage 24 VDC	14
H	HDDAB	Direct operated solenoid valve normally closed, with button emergency. Voltage 24 VDC	16
-	-	End section	—



General Instructions	36
Prescribed use of this power unit	36
Limits of use	36
Safety specifications	36
Identifying the unit	37
Compliance with directives	37
Operational limits	38
Storage	38
Choosing the hydraulic fluid	38
Installation	38
Start up	40
Tips	40
Maintenance	41
Dismantling and disposal	41

GENERAL INSTRUCTIONS

This manual applies to this HPU hydraulic power units.

The User is solely responsible for the use of this manual and completely assumes the relative risk. Dana Motion Systems Italia S.r.l. will not be responsible for special, indirect, accidental or consequential damage deriving from the use of this manual or the product, or from inexperience with the use of this manual or of the product. DANA will not be responsible - even to third parties - for poor or improper installation, maintenance, or repair of the product, or for the use of non-original replacement parts. This manual may not be reproduced, in whole or in part, in any form or by any means, for any use which is not the User's personal use, without the express written consent of DANA. DANA thanks you for choosing one of its products. In order to use the product correctly, DANA asks you to carefully follow the instructions and suggestions contained in this manual. This manual is intended for Users with trained personnel (who specialize in the hydraulics, electrical and mechanical sectors). This manual is no substitute for the professionalism and skill of the User's personnel. The User must make sure that its personnel have been provided with this manual and understand the instructions contained in it. Since DANA is committed to ongoing research and development, it reserves the right to modify the technical characteristics of its products, at any time and without prior notice, as deemed necessary. To ensure the availability of certain components, DANA draws upon a network of select, qualified suppliers; as a result, these components may vary in size and appearance. This manual is subject to change and addition but must not be considered to be out of date. Since HPU are complex products with configurations that vary a great deal, the diagrams contained in this manual are intended only to make it easier to understand the text and often do not show the product exactly as it is.



The HPU and its components may be assembled, installed, started and maintained by trained technical personnel, only.



The User is responsible for choosing the product and its accessories. Thus, it is important for the User to investigate the problems associated with its specific application by performing suitable analyses and tests. **The User is also responsible for installing the safety systems and affixing the warnings that are required by current regulations.**

PRESCRIBED USE OF THIS POWER UNIT

This HPU is designed to be the main control unit in hydraulic automation systems. Given the wide range of applications of HPU, and since the final destination of the unit is not always known to the manufacturer, this manual will provide information only on popular applications such as forklifts, lifting platforms and beds, lifts for cars, cranes on small trucks, snowplows, and automated systems in the industrial sector.

LIMITS OF USE

The manufacturer does not always know the final destination of the product. When the User chooses a HPU, it must therefore determine which product is suitable by running a test with a sample prototype. Our offices are available to help the User choose the correct HPU for its needs.



The HPU must not be used in the following applications:

- environments where there is a danger of explosion or fire
- aeronautical/space vehicles and systems
- braking, locking and retention systems in general
- equipment and systems used in military, nuclear, medical or hospital applications

In any case, DANA reserves the right - upon request - to evaluate the applications listed above and to authorize an application, if appropriate.



The HPU must not be used to perform safety functions.

The following are possible problem areas:

- Strong stresses and vibration may cause fluid to be ejected from the breather and fill cap.
- Highly dusty environments may cause the breather and fill cap to become plugged.
- Strong discharge pressure into the tank may generate foam and alter the characteristics of the hydraulic fluid.
- Exposing the HPU to sunlight may cause damage to the exposed plastic parts (especially the tanks).
- The DC motors must be wired using suitably large cables.
- Single-phase AC motors must be chosen to handle the minimum voltage available from the power mains.
- The electrically actuated valves that are normally used in these applications are not perfectly sealed, and this characteristic must be considered by the User when designing its machinery or equipment.
- Each HPU is given a final leak test under pressure, and its internal ducts are flushed to ensure cleanliness. As a result, the system where the HPU is installed should be perfectly clean, and the hydraulic fluid used must be clean and filtered

SAFETY SPECIFICATIONS

Your HPU has been designed and built to the current state of the art and complies with all applicable laws and regulations. The User is responsible for connecting the HPU to its machineries or equipment. The unit and the system where it is installed must be assembled, placed into service and maintained by properly trained personnel. A number of dangerous conditions that may occur during operation will now be described. Sometimes, a potentially dangerous situation may seem to be normal, but must not be underestimated. Likewise, the possibility of overconfidence and performing tasks by habit, which may take the place of paying proper attention to safety, must also not be underestimated.

 Unexpected spurts and leaks of hydraulic fluid hot enough to cause burns may occur during startup, normal operation, maintenance, adjustment, bleeding of the system, and operation and actuation of the valves and the control systems.

 Hydraulic fluid may be hazardous to health, since contact with the skin and eyes can cause serious damages. Carefully follow the instructions on personal protection and safety that are specified by the manufacturer of the fluid, as specified on the technical/toxicological information sheet.

 Hydraulic fluid may be a pollutant. As a result, it is good practice to avoid losing fluid by using basins to collect it. Also, use oil-absorbent products to protect the skin from accidental leaks and spurts of fluid.

 Never tamper with any valve, connection, accessory or component on the HPU. Simply loosening a valve may cause loads to fall freely or structures to give way.

 All installation, assembly, maintenance, disassembly and replacement operations on the HPU and its components must be performed in full compliance with safety regulations. During these operations, the hydraulic circuit must never be pressurized (zero pressure), and no load must be exerted on the tool or machinery the HPU is connected to (zero load).

 All electrical connections and disconnections must be performed by trained, specialized personnel.

 Before performing any type of operation or service on the HPU, electrically disconnect the power line (whether AC or DC) from the motors and from any other electrical device on the HPU.

 Before servicing non-electrical devices or motorization systems (whether pneumatic, hydraulic, mechanical, etc.), such devices and systems must first be disconnected from the relative feed lines and must be set up so that they cannot produce energy and thus cause movements, even accidentally.

 On HPU with a ventilated DC motor, some areas of the HPU may not be protected from moving parts (the fan). In this case, the User is responsible for providing suitable guards. Unprotected areas are labeled with a suitable warning.

Some parts of the HPU - and the hydraulic fluid itself - may



reach high temperatures and burn the skin. Be sure to follow all safety instructions.

The User must install the HPU in a position on the machinery and equipment that makes repair and maintenance procedures easy to perform.

When performing any such operation, it is good practice to:

- Use proper safety equipment (goggles, gloves, shoes, etc.);
- Work in conditions of utmost cleanliness and use tools, equipment and benches that are clean and in good operating condition;
- Work in conditions of maximum safety;
- Use oil-absorbent products.

IDENTIFYING THE UNIT

HPU are provided with identification labels. Some fields may be optional. HPU are identified by a part number and an ordering code on the documents provided with the units (invoice). All requests for explanations or replacement parts must be accompanied by the identification codes described above.

		BREVINI <small>Motion Systems</small>		MADE IN
Codice	CODICE ANAGRAFICO CODICE DI SELEZIONE			
Cod.Art.Cliente	CODICE CLIENTE			
ODP	NUMERO ODP	del DATA DI PRODUZIONE		
Q.tà	QUANTITA' LOTTO	NUMERO PROG.	I QUANTITA' LOTTO	
Cliente	NOME CLIENTE			
Cli. Finale	NOME CLIENTE FINALE			

COMPLIANCE WITH DIRECTIVES

Machinery Directive 2006/42/EC

This HPU is designed to be incorporated into another machinery and may be placed into service only when that machinery has been certified as complying with Machinery Directive 2006/42/EC.

EMC Directive 2014/30/UE

AC Motor – Three-phase or single-phase: not applicable.
DC motor - Field wound: compliant.
DC Motor - Permanent-magnet type: not compliant. The User must install an interference filter on the power line.

LV Directive 2014/35/UE

AC Motor - Three-phase or single-phase: compliant.
DC motor - Excluded from the Directive (up to 75 V).

OPERATIONAL LIMITS

Flow rate: The flow rate is determined by the pump and motor chosen. This HPU is designed to handle an optimal minimum flow rate of 5 L/min and a maximum flow rate of 20 L/min.

Minimum pressure: This HPU is built to control a minimum pressure of 10 bar. The same minimum pressure is also required for proper operation of possible flow regulators that control the outgoing flow.

Maximum pressure: The maximum pressure is determined by the pump, the motor and the relief valve (hereafter referred to as the RV). Nevertheless, all the components in the HPU have been chosen to suit the RV that is installed.

Under the most severe conditions and with specific components, the pressure limits are as follows:

250 bar: intermittent operating pressure

290 bar: intermittent peak pressure for a max. of 20 s

320 bar: overshooting pressure

 **The RV must not be replaced without prior authorization from DANA**

Temperature: This HPU is designed to operate with fluid at a temperature of -10 to 70° C. See the chapter, "Choosing the Hydraulic Fluid" for more information on temperature limits.

Since rapid temperature changes may deteriorate the properties and service life of the fluid, it is essential to protect the fluid from this type of situation.

STORAGE

HPU must be handled with care and attention. Certain protruding parts may be subject to breakage, such as the breather and fill cap on the tank. Another weak point is the tank made of plastic. Pay special attention to the flange, its valves and its components since they are particularly vulnerable to impact. If the HPU is equipped with valve assemblies, they must be protected from impacts and dents. Also, avoid bending the assemblies excessively, as this could cause irreversible damage. For HPU with tanks of small dimensions, since the motor is the heaviest component on an HPU, it is essential that the HPU be stored horizontally (and never vertically, with the tank underneath and the motor on top). An HPU must be placed in an environment that is protected from dust and direct sunlight (UV rays), and at an ambient temperature of -10 to +30 °C (up to 40°C max. for brief periods).

CHOOSING THE HYDRAULIC FLUID

Any mineral-based hydraulic fluid can be used. When choosing a fluid, the operational parameters of the system and the ambient temperature must be taken into consideration to obtain best performance. Use HM-HR-HV mineral-based hydraulic fluid meeting ISO 6743/4 (DIN 51524) specifications, with an ISO 3448-compliant viscosity class, and with the following conditions of use:

- minimum viscosity: **12 cSt** - maximum viscosity: **80 cSt**
- maximum viscosity at startup: **500 cSt**
- operating viscosity: **20 to 50 cSt**
- oil optimum operating temperature: **30° to 60 °C**
- minimum ambient temperature: **-15 °C**
- maximum ambient temperature: **40 °C (with peaks of 50 °C)**

 The use of other fluids may damage the system and prevent it from operating properly. In any case, DANA reserves the right - upon request - to evaluate the use of other fluids and to authorize such use if appropriate.

 Since each HPU is given a final test for proper operation, several cc of fluid with the above characteristics may remain in the unit.

 It is important not to mix hydraulic fluids from different manufacturers or fluids of different types. Such mixing may cause sludge and sediment to form that could prevent the HPU from operating properly.

 The values reported above are standard conditions of use that do not take into account the various types of tanks that may be installed and the resulting limitations. If plastic tanks are used, it is a good idea to consider that they offer poorer temperature performance.

Optimal temperature for using tanks made of sheet metal and polyethylene (PE): **-10 °C (ambient) to 70 °C (operating)**

Temperature limits for using tanks made of **sheet metal**: **-15 °C (ambient) to 80 °C (operating)**

Temperature limits for using tanks made of **polypropylene (PP)**: **-10 °C (ambient) to 60 °C (operating)**

The above parameters, which are the result of experience and laboratory tests, take into account the mounting systems and fasteners that are essential to machineries or equipment with average levels of vibration (transpallets in a workshop environment).

INSTALLATION

 During installation, be sure that important assembling operations are carried out with the greatest degree of cleanliness in a clean, dust-free area.

 The HPU must be installed in an ergonomic position that provides easy access for inspection and maintenance. It is just as important to install it in an area which is protected from accidental impact and kept away from accidental physical contact, since the high temperature of the unit during operation may cause burns.

 The HPU must be securely fastened to the machinery at its sturdiest points (such as the load-bearing frame, longitudinal members, etc), away from all sources of noise and vibration, and away from parts of machinery that may vibrate or transmit and/or amplify noise and vibration.

HPU with a plastic tank must be installed in areas with limited temperature swings and away from direct exposure to sunlight.

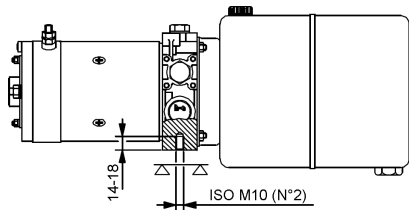

The HPU must be installed using the two ISO M10 holes in its aluminum body. The HPU described above may be installed with a special foot that is available upon request. On fixed machineries (horizontal or vertical position), the weight limits recommended for fastening with the two M10 holes are:

- with B14 AC motor, size 112
- with 10 L tank
- with 12 L tank and the additional support of the feet on the tank.

On moving machineries (the vertical position is preferable, mount the unit close to the center of gravity), the weight limits recommended for fastening with two M10 holes are:

- with all DC motors
- with 6 L tanks in sheet steel
- with 5 L tanks in PP
- with 4 L tanks in PE

Tanks with a higher capacity can be installed on HPU for special applications. For example, the tank can be anchored to the frame of a moving vehicle.

General rules for correct installation

- i** Examine the hydraulic diagram and the electrical diagram (if available). Our technical/business office is at your disposal for further information/explanations.
- i** Avoid removing the plastic protection plugs until you connect the hoses.
- i** Some electrically actuated valves have a screw-type manual safety device. This safety must be deactivated before operating the system.
- i** For HPU equipped with CETOP modular assemblies for connecting proportional solenoid valves, use DIN EN ISO 1179-2 cylindrical fittings with ISO 228-1 threads as the connection ports.
- i** Remember that when a steel fitting with a dented male thread is tightened, it will remove burrs from a female (aluminum) seat. These burrs are the main cause of valve malfunctions.

Connecting a DC motor
Sample connection diagram:

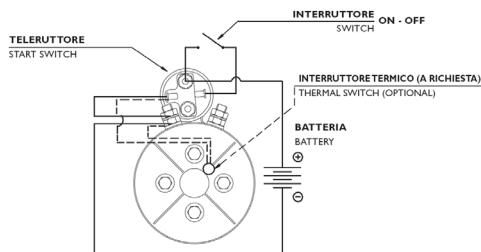

i When wiring a motor, it is important to consider the cross-sectional area and length of the power cables. Cables with overly small cross-sections and overly long lengths may cause voltage drops that could prevent the HPU from operating properly.

Before placing the HPU into service, we recommend cycling the start switch several times at low to medium loads to break in the switching system.

Use these tightening torque values on the motor terminals and the start switch

[Nm]	ISO M8	5 to 7
	ISO M6	3 to 5

Connecting an AC motor
Mechanical connection to AC motors with form factor B14: the motor side of the transmission coupling must be mounted at the distances shown on the table

Grand.	Coupling distance	
	Z (pump group 1) in mm	Z (pump group 05) in mm
63	42.8	62.7
71	42	42
80	53	53
90	63	63
100	81.5	81.5

Sample electrical connection of three-phase AC motors:

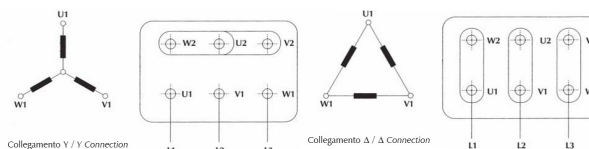

! Electrical connections to the motor and to electrically actuated valves must be made by trained personnel. Before these devices are connected to the power line, the following factors must be considered:

- The laws and technical standards applicable in the installation location
- The data indicated on the motor identification plate and on the valves

! The electric power feed line connected to the motor must be a multi-core cable with a cross-sectional area that is large enough to meet current regulations. The cable enters the terminal board through a special cable gland and is connected to the terminals. The voltage supplied to the motor must be the same as the voltage specified on its identification plate.

! The housing for the terminal board contains metal components carrying dangerously high voltage. Be sure to close the cover of the housing after wiring the terminal board.

i Single-phase AC motors must be chosen that operate at the minimum voltage supplied by the power mains. The motor will not operate properly if the voltage is too low. Connecting electrically actuated valves

! On HPU with electrically actuated valves, the coils must be supplied with the prescribed voltages with the following limits: -10 to +5% of nominal voltage. If these limits are exceeded, valve operation and coil life may be adversely affected.

Hydraulic connection

i The hydraulic connection must be made with cylindrical fittings and copper sealing gaskets. We recommend using DIN EN ISO 1179-2 fittings with ISO 228-1 threads and DIN 7603 gaskets. The ports on the HPU and on the valve assemblies (if installed) are protected by plastic plugs that must be removed when the fittings are installed. Check the thread on the fittings, which must be clean and without dents. Use rigid or flexible hoses whose internal diameter is the same as or larger than the connecting orifices on the HPU. The speed of the fluid in the hoses must be as follows:

delivery (pressure): 4 to 6 m/s
return (discharge): 1.5 to 3 m/s

The recommended values must be increased if very long sections of hose (over 3 m) are used.

The system must be clean to obtain proper operation from the HPU.

The following table lists flow rates and tightening torque values for UNI-ISO 228 gas threads

Flow rate (L/min)	Thread	 [Nm]
<5 to 10	G 1/4"	30
10 to 20	G 3/8"	30
>20	G 1/2"	30

Installation of manual pressure control group

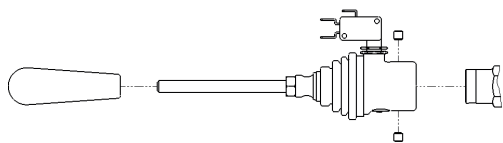

Usually, the manual pressure control group is not installed.

- Grease the internal parts of the manual pressure control and the valve where the unit will be installed (use gasket grease).
- Insert the lever until the cam hits the pin.
- Arrange as desired and fasten with the two screws: 4 Nm.

In case of malfunction (difficult operation, oil leaks, etc.),

! **remove the manual pressure control group from the machinery when it is shut down with the power disconnected. Make sure the pressure in the hydraulic system is zero.**

All operations on the HPU must be carried out with

! **the machinery shut down and with the power disconnected. Make sure the pressure in the hydraulic system is zero.**

START UP

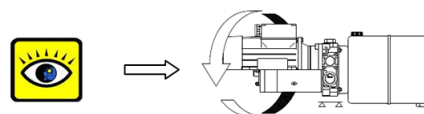

The direction of motor rotation is clockwise CW, as observed from the side of the HPU where the motor is located (unless a different direction of rotation was specified on the order and the different direction is determined by the type of flange on the unit). The direction of rotation must be checked on all AC motors and on DC motors with permanent magnets. It is better to check the direction of rotation when the motor is not installed; or, proceed as follows:

- Wire the motor as specified
- Adjust the RV to minimum
- Actuate the HPU with very short pulses
- Adjust the RV for normal operation

i If the motor rotates in the wrong direction, the pump may be permanently damaged when it reaches operating pressure. The connections to the motor and its direction of rotation must be checked every time the HPU or the system is disconnected from the power mains.

After the system is started, make sure all the controls operate properly. When executing the first movements with the system, air must be bled from the system to prevent foam forming in the tank and possible undesired and uncontrollable movements of the actuators.

Also, recheck the fluid level and top it up if necessary. After the system has operated for a few hours, check the entire HPU for fluid seepage, recheck the fluid level in the tank, and again look for foam in the tank.

TIPS

Read the following chapters: "Prescribed use of this Power Unit", "Limits of Use", "Safety Specifications", "Operational Limits", "Installation".

The operations described below are the recommended way to start up the unit properly.

Fill the tank with new, filtered hydraulic fluid (see the chapter, "Choosing the Hydraulic Fluid").

Disconnect the pressure hose from the cylinder and place it into a clean container. Do not allow hydraulic fluid to flow into drains or discharge channels, or onto the ground.

Turn the motor on the HPU on and off at intervals of 1 s until hydraulic fluid is ejected from the pressure hose.

Reconnect the pressure hose to the cylinder and top up the tank. Execute a number of complete cycles on the cylinder to purge the air from the circuit and check the level of hydraulic fluid once again.

Make sure the RV is set correctly.

The most common cause of breakage, poor operation and premature wear of hydraulic systems is lack of cleanliness. For this reason, make sure all hoses and cylinders are perfectly clean during assembly.

MAINTENANCE

Proper operation of the HPU (and of the system it is installed in) also depends on correct maintenance. After a short period of operation, make sure all the screws and fittings are tight, since pulsation and vibration may cause these components to loosen, which may lead to leakage and seepage of hydraulic fluid. It is important to keep the HPU clean so that leaks and seepage can be more easily seen. Only use clean cloths for cleaning.

Never use solvents or detergents.

i Check the level and the condition of the hydraulic fluid. We recommend changing the fluid the first time after the first 10 hours of operation. Afterwards, change the fluid every 3000 hours of operation (or once a year).

Whenever the hydraulic fluid is changed, replace the intake filter (and the other filters, if installed) and clean the inside of the tank. It is a good idea to change the fluid by removing the tank (see the chapters, "Removing and reinstalling the tanks" and "Replacing the Filter").

Before changing the hydraulic fluid, empty the entire system completely. The fluid change interval described above applies at operating temperatures of 30° C to 60 °C (temperature of the hydraulic fluid).

Higher temperatures may seriously reduce the service life of the fluid.

Replacing the filter

The filter can be replaced with a new filter of the same type or it can be washed, cleaned and reused (see the section, "Safety Specifications").

Proceed as follows:

- Unscrew the filter while holding on to the intake hose to prevent it from unscrewing
- Clean or replace the filter
- Screw the filter back into place onto the same section of threading on the hose. Use enough force so that the metal thread on the filter is snugly seated on the hose.

Removing and reinstalling the tanks

Removal

- Unscrew the mounting system
- Pull out the tank, but without the aid of levers that could cause dents

Reinstallation

- Make sure the tank is clean
- Make sure the sealing gasket is in good condition
- Make sure the opening on the collar of the tank is in good condition (it must be clean, free from dents and without unusual grooves)
- Grease the opening on the collar of the tank
- Install the tank
- Secure the tank tightening the screw evenly

i It is a good idea to grease the opening of the tank and not the gasket. The HPU will be cleaner because the grease will flow toward the inside of the tank.

The tanks have different mounting systems

Direct mounting using the threading on the tank (usually made of sheet metal)	M6	 [Nm]	6
Mounting with a bracket (usually for PP tanks)			
Mounting with a collar band (usually for PE tanks)			

Screwing plugs into the tank

Plastic plug with key	Thread G 1/2" G 3/4"	 [Nm]	10
Manually tightened plastic plugs			By hand
Metal plugs			30

Recommended tightening torque values

If components on the HPU must be removed and reinstalled, tighten them at the torque values listed on the following table:

Tightening torque values to be used on the screws or tie rods used to fasten motors

	M8	M6	M5	1/4-20 UNC
 [Nm]	25	10	6	10

i For tightening torque values used on the terminals of DC motors and start switches, see the paragraph, "Connecting a DC motor"

Tightening torque values to be used on the flange body

	M6	M8	M10x1.5	M16x1.5	3/4 -16UNF	G1/4	G3/8
 [Nm]	10	25	45	30	30	30	30*

i The recommended tightening torque values on the table are differentiated according to material and type of thread on the flange body and apply to the components that are most commonly removed. The values do not apply to other components made of different materials (plastic) or components that are tightened using other methods (such as slot-head or Philips head screwdrivers, or other tools), or unless otherwise specified. The torque values do not apply to plugs and fittings with tapered threads.

DISMANTLING AND DISPOSAL

If the HPU must be dismantled, empty the fluid and dispose of it according to the laws that apply in the country where it will be disposed of. The same holds true for the other parts of the HPU; that is, dispose of them according to the laws that apply to disposal of plastic and ferrous materials, as the case may be.

When dismantling the unit, separate the plastic parts from the electrical components, which must be disposed of separately in accordance with current regulations.

The large metal sections of the HPU should be separated into parts made of steel and parts made of other metals or alloys, so that they can be correctly melted down for recycling. Dismantling is not a particularly risky operation, as long as it is performed by properly trained personnel using adequate tools (see the chapter, "Safety Specifications").



BREVINI[®]

Motion Systems

© 2022 Dana Limited. All rights reserved.

The product images and drawings shown are for illustration purposes only and may not be an exact representation of the product.

The technical features supplied in this catalogue are non binding and no legal action can be taken against such material. Dana will not be held responsible for information and specifications which may lead to error or incorrect interpretations. Given the continuous technical research aimed at improved technical features of our products, Dana reserves the right to make change that are considered appropriate without any prior notice. This catalogue cannot be reproduced (in whole or in part) without the prior written consent of Dana. This catalogue supersedes all previous ones.

Use of the products in this catalogue must comply with the operating limits given in the technical specifications. The type of application and operating conditions must be assessed as normal or in malfunction in order to avoid endangering the safety of people and/or items.



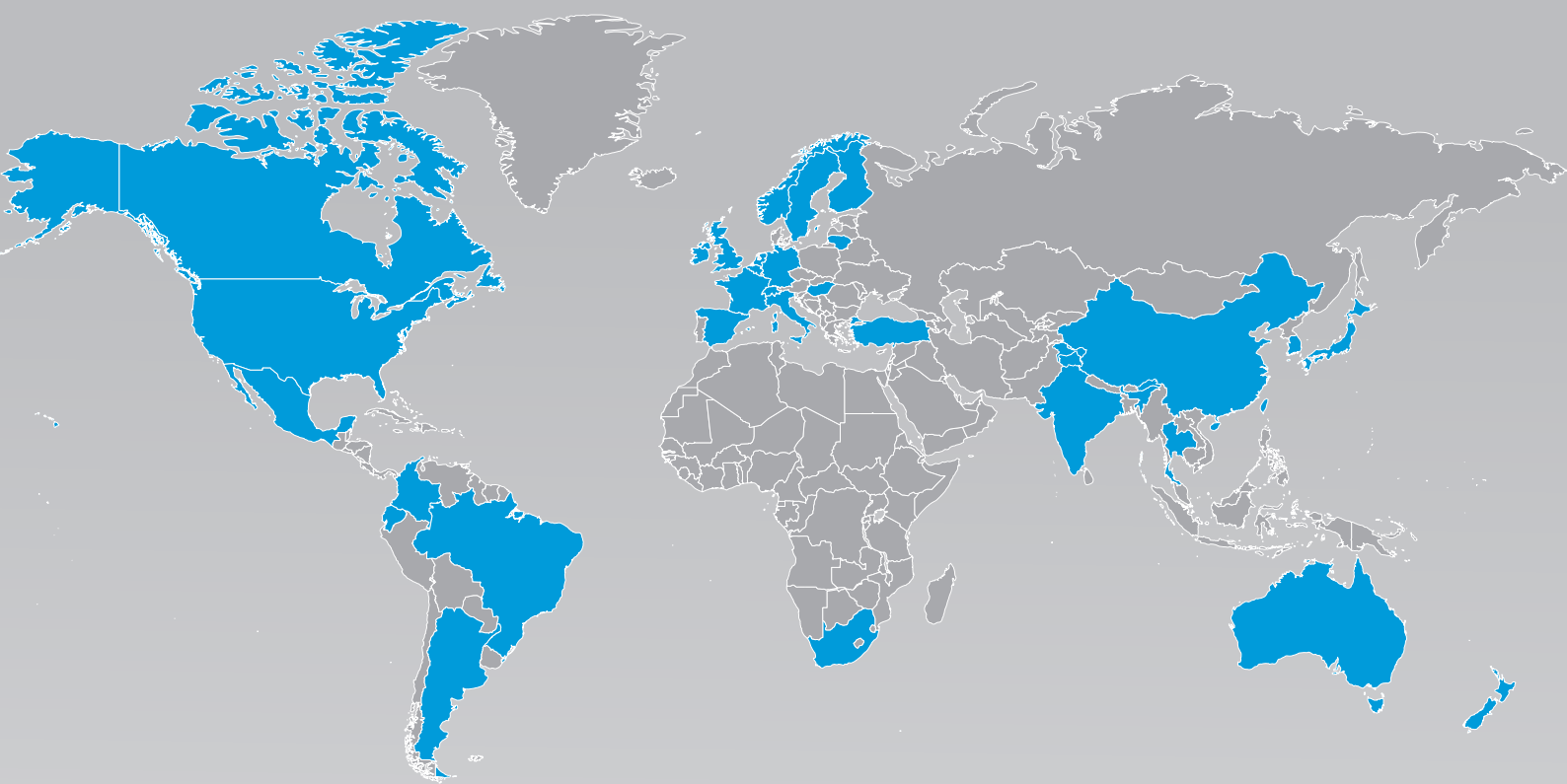

Technologies Customized to Every Part of the Globe

With a presence in 31 countries, Dana Incorporated boasts more than 150 engineering, manufacturing, and distribution facilities. Our worldwide network of local service centers provides assurance that each customer will benefit from the local proximity and responsiveness.

About Dana Incorporated

Dana is an integral partner for virtually every major vehicle and engine manufacturer worldwide. We are a leading supplier of drivetrain, sealing, and thermal technologies to the global automotive, commercial-vehicle, and off-highway markets. Founded in 1904, we employ thousands of people across six continents.



About Dana Off-Highway Drive and Motion Technologies

Dana delivers fully optimized Spicer® drivetrain and Brevini® motion systems to customers in construction, agriculture, material-handling, mining, and industrial markets. We bring our global expertise to the local level with technologies customized to individual requirements through a network of strategically located technology centers, manufacturing locations, and distribution facilities.

Learn more about Dana's drivetrain and motion systems at dana.com/offhighway.

Dana-Industrial.com

Application Policy

Capacity ratings, features, and specifications vary depending upon the model and type of service. Application approvals must be obtained from Dana; contact your representative for application approval. We reserve the right to change or modify our product specifications, configurations, or dimensions at any time without notice.



BREVINI®

Motion Systems



1800-OILSOL
1800-645765

<https://oilsolutions.com.au/>

sales@oilsolutions.com.au