

BUCHER
hydraulics



OIL SOLUTIONS

HYDRAULIC POWER UNITS

PO Box 38
Strathfieldsaye, VIC, 3551
1800 OIL SOL
1800 645 765
sales@oilsolutions.com.au
www.oilsolutions.com.au
"For All Your Hydraulic Needs"

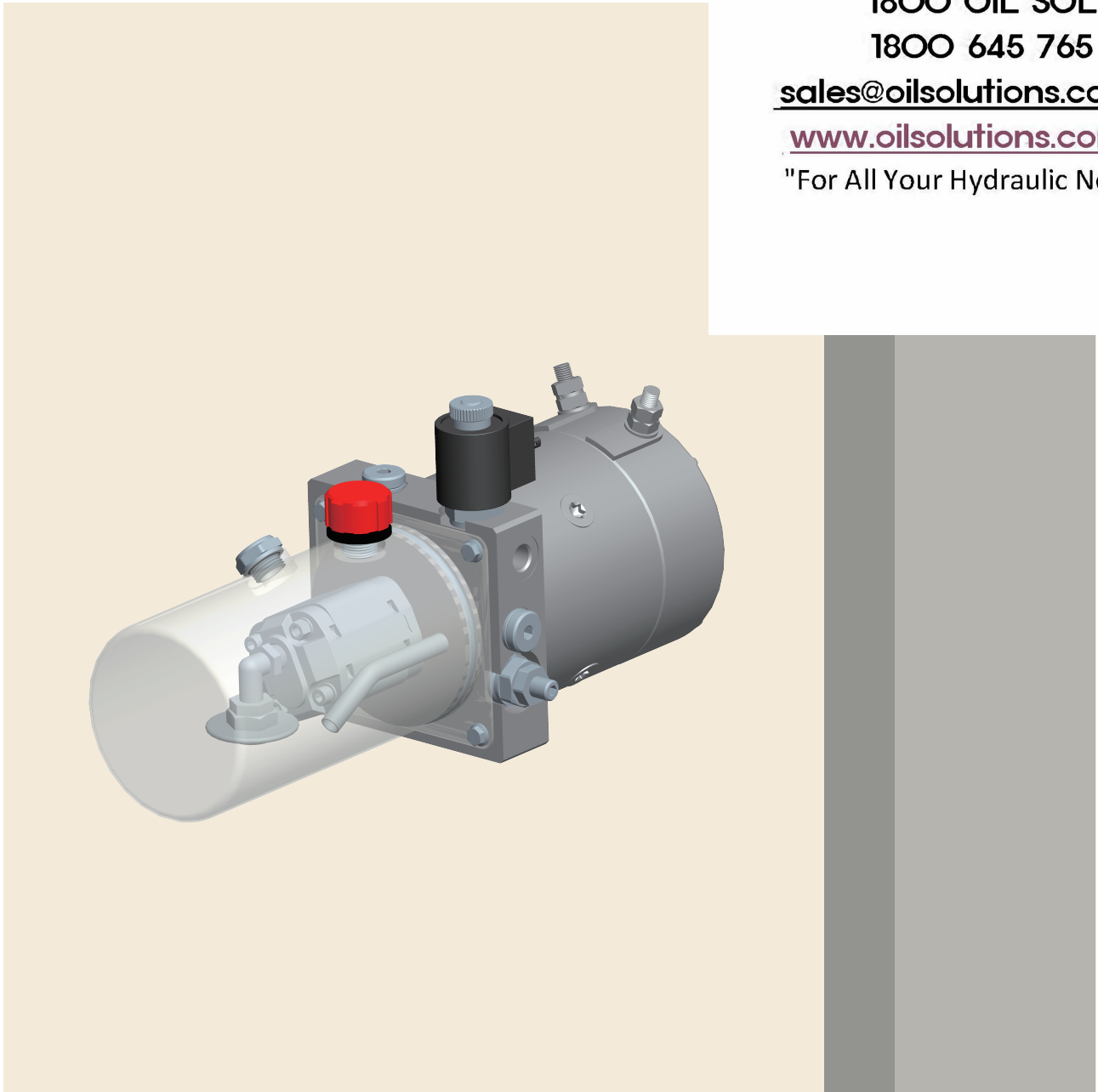

Bucher Hydraulics (Wuxi) CO.,Ltd.

Contents

POWER UNITS ORDERING GUIDANCE	01
POWER UNITS FOR FORK LIFT 1	03
POWER UNITS FOR FORK LIFT 2	04
POWER UNITS FOR FORK LIFT 3	05
POWER UNITS FOR FORK LIFT 4	06
PALLET TRUCK POWER UNITS 1	07
PALLET TRUCK POWER UNITS 2	08
POWER UNITS FOR DOCK LEVELER 1	09
POWER UNITS FOR DOCK LEVELER 2	10
POWER UNITS FOR DOCK LEVELER 3	11
POWER UNITS FOR DOCK LEVELER 4	12
AUTO HOIST POWER UNITS 1	13
AUTO HOIST POWER UNITS 2	15
AUTO HOIST POWER UNITS 3	16
POWER UNITS FOR LIFT TABLE 1	17
POWER UNITS FOR LIFT TABLE 2	18
POWER UNITS FOR DUBBLE-SCISSORS LIFT 1	19
POWER UNITS FOR DUBBLE-SCISSORS LIFT 2	20
POWER UNITS FOR SCISSOR LIFT	21

Contents

ELECTRIC-BASKETBALL STANDS POWER UNITS	22
POWER UNIT FOR TIRE CHANGER	23
TIPPER TRAILER POWER UNITS 1	24
TIPPER TRAILER POWER UNITS 2	25
TIPPER TRAILER POWER UNITS 3	26
TIPPER TRAILER POWER UNITS 4	27
POWER UNITS FOR SNOW PLOW	28
WHEEL CHAIR POWER UNITS	29
RV POWER UNITS 1	30
RV POWER UNITS 2	31
POWER UNITS FOR MEDICAL CARE EQUIPMENT	32
POWER UNITS FOR ROAD PILE	33
POWER UNITS FOR TAIGATEK OF GARBAGE TRUCK	34
POWER UNITS FOR VEHICLE TAILGATE	35
DC MOTOR PUMP GROUP 1	36
DC MOTOR PUMP GROUP 2	37
DC MOTOR PUMP GROUP 3	38

POWER UNITS ORDERING GUIDANCE

$$\frac{\text{YBZ} \begin{array}{|c|} \hline \square \\ \hline \end{array} - \begin{array}{|c|} \hline \square \\ \hline \end{array} \begin{array}{|c|} \hline \square \\ \hline \end{array} \begin{array}{|c|} \hline \square \\ \hline \end{array} \begin{array}{|c|} \hline \square \\ \hline \end{array} \begin{array}{|c|} \hline \square \\ \hline \end{array} \begin{array}{|c|} \hline \square \\ \hline \end{array}}{\begin{array}{|c|} \hline (1) \\ \hline \end{array} \begin{array}{|c|} \hline (2) \\ \hline \end{array} \begin{array}{|c|} \hline (3) \\ \hline \end{array} \begin{array}{|c|} \hline (4) \\ \hline \end{array} \begin{array}{|c|} \hline (5) \\ \hline \end{array} \begin{array}{|c|} \hline (6) \\ \hline \end{array} \begin{array}{|c|} \hline (7) \\ \hline \end{array} \begin{array}{|c|} \hline (8) \\ \hline \end{array}} / \begin{array}{|c|} \hline \square \\ \hline \end{array} \begin{array}{|c|} \hline \square \\ \hline \end{array} \begin{array}{|c|} \hline \square \\ \hline \end{array} \begin{array}{|c|} \hline \square \\ \hline \end{array} \begin{array}{|c|} \hline \square \\ \hline \end{array} \begin{array}{|c|} \hline \square \\ \hline \end{array}}{\begin{array}{|c|} \hline (9) \\ \hline \end{array} \begin{array}{|c|} \hline (10) \\ \hline \end{array} \begin{array}{|c|} \hline (11) \\ \hline \end{array} \begin{array}{|c|} \hline (12) \\ \hline \end{array} \begin{array}{|c|} \hline (13) \\ \hline \end{array} \begin{array}{|c|} \hline (14) \\ \hline \end{array}}$$

- (1) Product name:hydraulic power units
- (2) Series No.,which would be changed once there comes big improvement of the whole.power units.It comes into 1,2,3,4. Especially,the No.5 represents manifold made of aluminium. the No.6 represents manifold made of die-casting aluminium.
- (3) System pressure, which is used to point out the preset pressure of the relief valve.
A-1.6MPa B-2.5MPa C-6.3MPa D-10MPa E-16MPa F-20MPa G-25MPa H-32MPa
- (4) Rated pump displacement
 ①CBK series pumps;
 0.63ml/r 0.8ml/r 1.2ml/r 1.6ml/r 2.1ml/r 2.5ml/r 2.7ml/r 3.2ml/r 3.7ml/r 4.2ml/r 5ml/r 6ml/r 8ml/r
 ②CBG series pumps;
 2ml/r 3ml/r 3.5ml/r 4ml/r
 ③CBE series pumps
 0.26ml/r 0.32ml/r 0.38ml/r 0.5ml/r 0.63ml/r 0.88ml/r 1.00ml/r 1.25ml/r 1.5ml/r
- (5) Oil tank capacity
 U—0.5L V—0.8L W—1.0L S—1.4L Y—1.5L Z—2.0L A—3.0L or 4.0L B—5L or 6L C—8.0L D—10L
 E—12L F—14L G—16L H—20L I—22L J—25L K—35L L—50L M-60L N—70L P—80L Q—13L R—30L S—7L
 X-2.5L T-100L TA-120L
- (6) Motor voltage
 ①DC motor: 1-12V 2-24V 9-48V 10-72V 12-60V
 ②AC motor: 3—220V 4—380V 5—110V 6—415V 7—230/460V 8—115/230V 11—200V
 13-110/220V 14-220/380V 15-230/400V 16-460V 17-400V 18-240V 19-120V 20-190/208-240/380V/460
 21-230V 22-440V 23-100V 24-230/460/575V 25-208/230/460/380/400V 26-277V 27-220/44V 28-575V
- (7) Motor power
 ①DC motor:X—0.25kw S—0.5kw T—0.8kw U—1.0kw V— 1.2kw W—1.5kw A—2.0kw M-2.2kw
 N-2.5kw L-1.8kw B—3.0kw P-4.0kw
 ② AC motor:C—0.37kw D—0.55kw E—0.75kw F—1.1kw G— 1.5kw H—2.2kw I—3.0kw J—4.0kw
 Q-0.85kw R-1.8kw K-3.7kw
- (8) Hydraulic circuit No.See the hydraulic schematic circuit in the detailed page.
- (9) Motor type
 O—no motor
 T—the motor with Special requirements
 ①AC motors
 A—Steel housing, vertical & horizontal,9T Spline,the center distance of the mounting hole is 113x113.
 B—Steel housing, vertical,9T Spline,the center distance of the mounting hole is 113x113.
 G—Extruding aluminium housing. vertical & horizontal,Tang,the center distance of the mounting hole is 113x113.
 H—Extruding aluminium housing. vertical,Tang,the center distance of the mounting hole is 113x113.
 L—Casting aluminium housing. vertical & horizontal, 9T Spline,the center distance of the mounting hole is 113x113.
 M—Casting aluminium housing. vertical,9T Spline,the center distance of the mounting hole is 113x113.
 N—Casting aluminium housing. vertical & horizontal,Tang,the center distance of the mounting hole is 117.4x117.4.
 ② DC motors

POWER UNITS ORDERING GUIDANCE

U—3 " DC motor(0.34HP-1.1HP)
V—3.5 " DC motor(1.1HP-1.6HP)
W—4.5 " DC motor(2HP-3HP)
X—5 " DC motor(4HP)

(10) Motor speed

O—Hydraulic system in the non-motor
T—the motor with Special requirements
①50HZ AC motor,50HZ A—960rpm B—1450rpm C—2850rpm D—1450/2850rpm
②60HZ AC motor,60HZ J—1100rpm K—1750rpm L—3450rpm
③50HZ/60HZ M-50HZ/60HZ N-50HZ/60HZ
④DC motor U—2500rpm V—3500rpm W—4500rpm

(11) Tank appearance

A—neck i.d ϕ 120, steel, round, horizontal.
B—neck i.d ϕ 120, steel, round, vertical.
C—neck i.d ϕ 120, steel, square, horizontal.
D—neck i.d ϕ 120, steel, square, vertical.
E—neck i.d ϕ 138, steel, round, horizontal.
F—neck i.d ϕ 138, steel, round, vertical.
G—neck i.d ϕ 138, steel, square, horizontal.
H—neck i.d ϕ 138, steel, square, vertical.
J—neck i.d ϕ 94, steel, round, horizontal.
K—neck i.d ϕ 94, steel, round, vertical.
L—neck i.d ϕ 94, steel, square, horizontal.
M—neck i.d ϕ 94, steel, square, vertical.
N—neck i.d ϕ 120, steel, round, 200
P—neck i.d ϕ 120, blow-molded plastic, round, horizontal.
Q—neck i.d ϕ 120, blow-molded plastic, round, vertical.
R—neck i.d ϕ 73, steel, square, horizontal.
S—neck i.d ϕ 73, steel, square, vertical.
U—neck i.d ϕ 120, injection molded plastic, round, horizontal.
V—neck i.d ϕ 120, injection molded plastic, round, vertical.
O—non-tank
T—the tank with Special requirements.

(12) Solenoid valve volt

A—12VDC, without manual override function.
B—24VDC, without manual override function.
C—24VAC, without manual override function.
D—110VAC, without manual override function.
E—220VAC, without manual override function.
H—12VDC, with manual override function.
I—24VDC, with manual override function.
J—24VAC, with manual override function.
K—110VAC, with manual override function.
L—220VAC, with manual override function.
O—No solenoid valve.
T—The solenoid valve with special requirements.
Z—referring to the manual valve with micro switch.

(13) Manifold model is selected by manufacturer.

(14) Design No. which is selected by manufacturer, may be 1,2,3 or A,B,C.

POWER UNITS FOR FORK LIFT 1

General Description

- High Pressure and Low Noise Gear Pump/DC Motor/- Multi-functional Manifold/Valve/Tank
- Manual Release Valve with an Electric Switch for the Motor Starter
- The Lowering Speed is Adjusted by the Pressure Compensated Flow Control Valve

Hydraulic Circuit Diagram

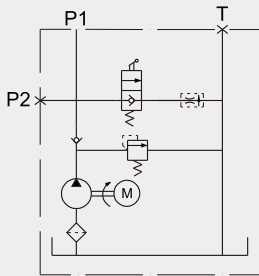

Special Notes

- This type of power unit works at S3 duty cycle, i.e., intermittent duty, 30 seconds on-load and 270 seconds off-load.
- Clean all the hydraulic parts concerned before mounting the power unit.
- Viscosity of the hydraulic oil should be 15~68 cst, which should also be clean and free of impurities. N46 hydraulic oil is recommended.
- Check the oil level in the tank after the initial operation of the power unit.
- Oil changing is required after the initial 100 operation hours, afterwards once every 3000 hours.

Outline Dimension

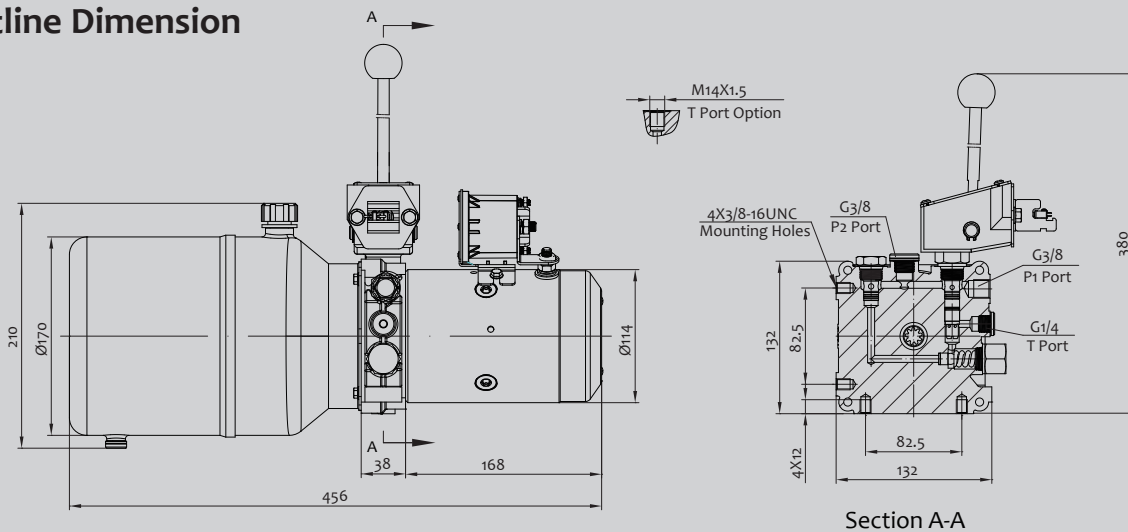

Model Specifications

Model	Motor Voltage	Motor Power	Rated Speed	Displacement	System Pressure	Tank Capacity
YBZ6Q-F1.6B1W1/WUAZD9	12VDC	1.5KW	2500RPM	1.6ml/r	20MPa	5L
YBZ6Q-F2.1B1W1/WUAZD9				2.1ml/r		
YBZ6Q-F2.1B2A1/WUAZD1	24VDC	2KW		2.5ml/r		

Remark: Please go to page 1 or consult our sales engineer for the different pump displacement, motor power or system pressure.

POWER UNITS FOR FORK LIFT 2

General Description

- High Pressure and Low Noise Gear Pump/DC Motor/- Multi-functional Manifold/Valve/Tank
- Normally Closed Solenoid Operated Lowering Valve
- The Lowering Speed is Adjusted by the Pressure Compensated Flow Control Valve

Hydraulic Circuit Diagram

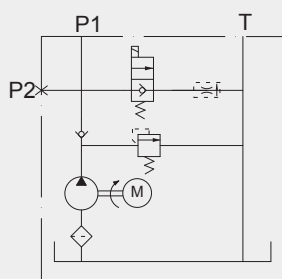

Special Notes

- This type of power unit works at S3 duty cycle, i.e., intermittent duty, 30 seconds on-load and 270 seconds off-load.
- Clean all the hydraulic parts concerned before mounting the power unit.
- Viscosity of the hydraulic oil should be 15–68 cst, which should also be clean and free of impurities. N46 hydraulic oil is recommended.
- Check the oil level in the tank after the initial operation of the power unit.
- Oil changing is required after the initial 100 operation hours, afterwards once every 3000 hours.

Outline Dimension

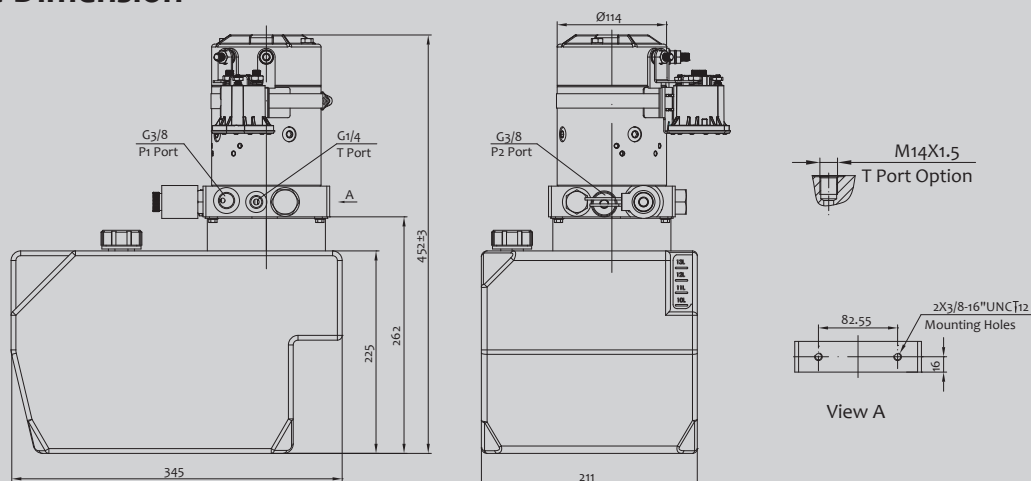

Model Specifications

Model	Motor Voltage	Motor Power	Rated Speed	Displacement	System Pressure	Tank Capacity	Solenoid Valve Voltage
YBZ5Q-F2.5E1A2/WUQAT1	12VDC	2KW	2500RPM	2.5ml/r	20MPa	12L	12VDC
YBZ5Q-F2.7E1A2/WUQAT1				2.7ml/r			
YBZ5Q-F2.5E2M2/WUQBT1	24VDC	2.2KW		2.5ml/r			
YBZ5Q-F3.2E2M2/WUQBT1				3.2ml/r			

Remark: Please go to page 1 or consult our sales engineer for the different pump displacement, motor power or system pressure.

POWER UNITS FOR FORK LIFT 3

General Description

- High Pressure and Low Noise Gear Pump/DC Motor/- Multi-functional Manifold/Valve/Tank
- Normally Closed Solenoid Operated Lowering Valve
- The Lowering Speed is Adjusted by the Pressure Compensated Flow Control Valve

Hydraulic Circuit Diagram

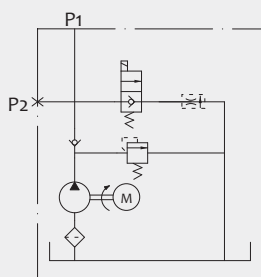

Special Notes

- This type of power unit works at S3 duty cycle, i.e., intermittent duty, 30 seconds on-load and 270 seconds off-load.
- Clean all the hydraulic parts concerned before mounting the power unit.
- Viscosity of the hydraulic oil should be 15~68 cst, which should also be clean and free of impurities. N46 hydraulic oil is recommended.
- Check the oil level in the tank after the initial operation of the power unit.
- Oil changing is required after the initial 100 operation hours, afterwards once every 3000 hours.

Outline Dimension

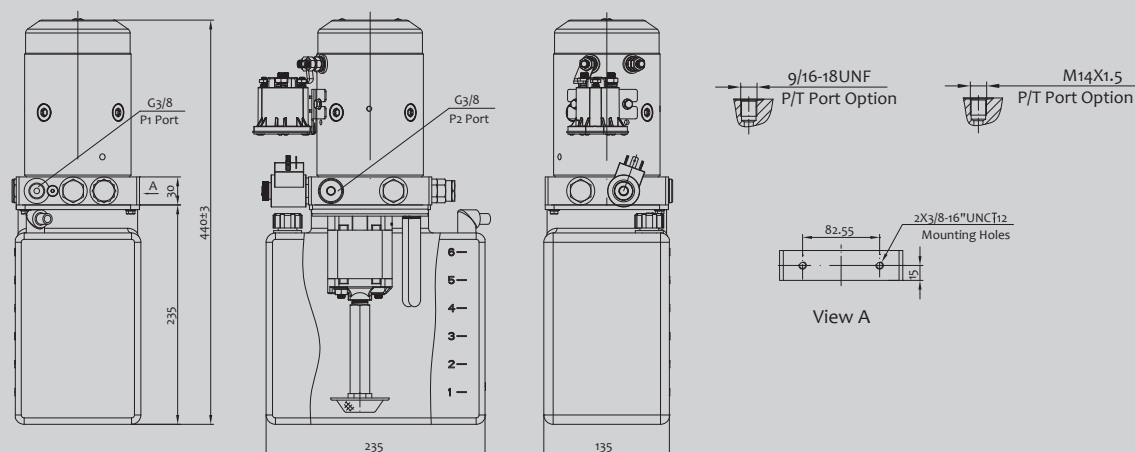

Model Specifications

Model	Motor Voltage	Motor Power	Rated Speed	Displacement	System Pressure	Tank Capacity	Solenoid Valve Voltage
YBZ5Q-E2.1B1W2/WUQAT11	12VDC	1.5KW	2500RPM	2.1ml/r	16-18MPa	6L	12VDC
YBZ5Q-E2.7B1W2/WUQAT11				2.7ml/r			
YBZ5Q-E3.2B2M2/WUQBT11	24VDC	2.2KW		3.2ml/r			24VDC
YBZ5Q-E3.7B2M2/WUQBT11				3.7ml/r			

Remark: Please go to page 1 or consult our sales engineer for the different pump displacement, motor power or system pressure.

POWER UNITS FOR FORK LIFT 4

General Description

- High Pressure and Low Noise Gear Pump/DC Motor/- Multi-functional Manifold/Valve/Tank
- Normally Closed Electro-hydraulic Proportional Valve
- The Lowering Speed is Controlled by the Electro-hydraulic Proportional Valve as Well as The Pressure Compensated Flow Control Valve

Hydraulic Circuit Diagram

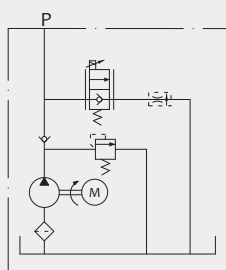

Special Notes

- This type of power unit works at S3 duty cycle, i.e., intermittent duty, 30 seconds on-load and 270 seconds off-load.
- Clean all the hydraulic parts concerned before mounting the power unit.
- Viscosity of the hydraulic oil should be 15–68 cst, which should also be clean and free of impurities. N46 hydraulic oil is recommended.
- Check the oil level in the tank after the initial operation of the power unit.
- Oil changing is required after the initial 100 operation hours, afterwards once every 3000 hours.

Outline Dimension

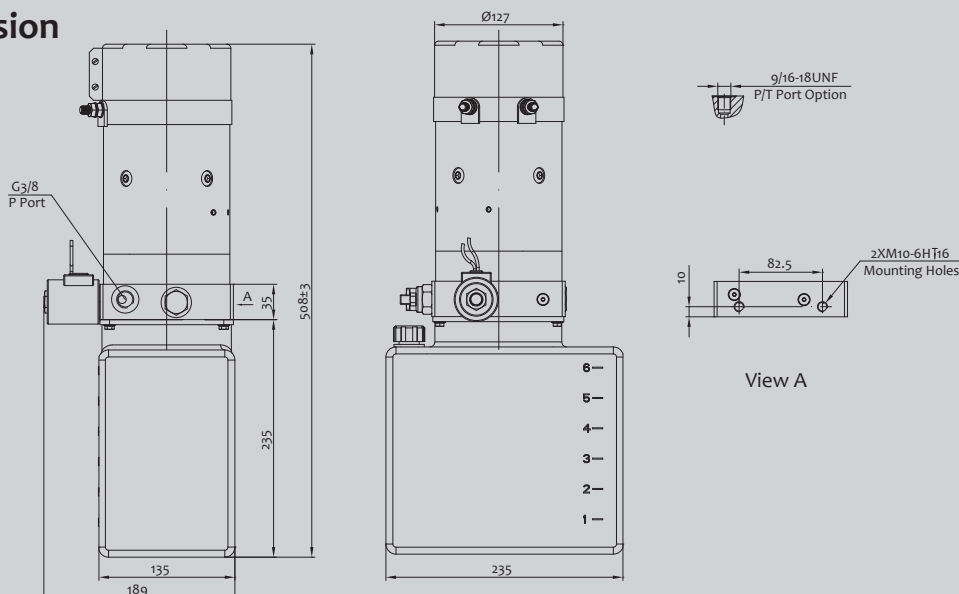

Model Specifications

Model	Motor Voltage	Motor Power	Rated Speed	Displacement	System Pressure	Tank Capacity	Solenoid Valve Voltage
YBZ5Q-F3.2B2B900/XVQBT1	24VDC	3KW	3500RPM	3.2ml/r	20MPa	6L	24VDC
YBZ5Q-E4.2B2B900/XVQBT1				4.2ml/r	16MPa		

Remark: Please go to page 1 or consult our sales engineer for the different pump displacement, motor power or system pressure.

PALLET TRUCK POWER UNITS 1

General Description

- High Pressure Gear Pump/ Low Noise DC Motor/- Multi-functional Manifold/Valve/Tank
- Normally Closed Solenoid Operated Lowering Valve
- The Lowering Speed is Adjusted by the Pressure Compensated Flow Control Valve

Hydraulic Circuit Diagram

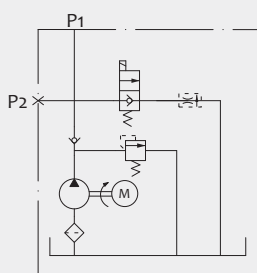

Special Notes

- This type of power unit works at S3 duty cycle, i.e., intermittent duty, 30 seconds on-load and 270 seconds off-load.
- Clean all the hydraulic parts concerned before mounting the power unit.
- Viscosity of the hydraulic oil should be 15~68 cst, which should also be clean and free of impurities. N46 hydraulic oil is recommended.
- Check the oil level in the tank after the initial operation of the power unit.
- Oil changing is required after the initial 100 operation hours, afterwards once every 3000 hours.

Outline Dimension

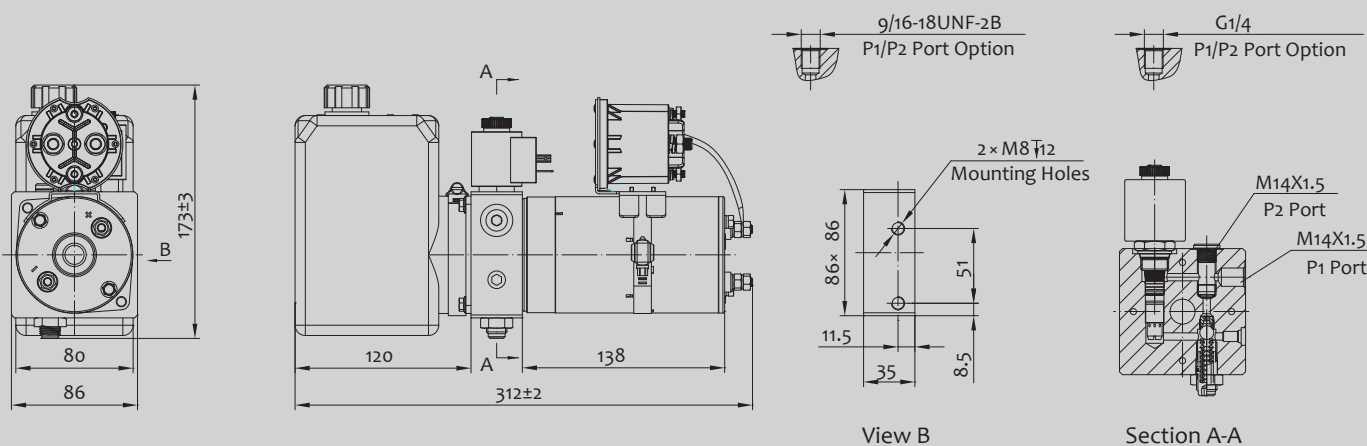

Model Specifications

Model	Motor Voltage	Motor Power	Rated Speed	Displacement	System Pressure	Tank Capacity	Solenoid Valve Voltage
YBZ5-E0.5W1T2/UVTAT1	12VDC	0.8KW	3500RPM	0.5mL/r	16MPa	1L	12VDC
YBZ5-E0.6W1T2/UVTAT1				0.6mL/r			
YBZ5-E0.6W2T2/UVTBT1	24VDC			0.75mL/r			24VDC
YBZ5-E0.75W2T2/UVTBT1				1.0mL/r			
YBZ5-E1.0W9T2/UVTTT1	48VDC						

Remark: Please go to page 1 or consult our sales engineer for the different pump displacement, motor power or system pressure.

PALLET TRUCK POWER UNITS 2

General Description

- High Pressure Gear Pump/ DC Motor/Multi-functional Manifold/Valve/Tank
- Normally Closed Solenoid Operated Lowering Valve
- The Lowering Speed is Adjusted by the Pressure Compensated Flow Control Valve

Hydraulic Circuit Diagram

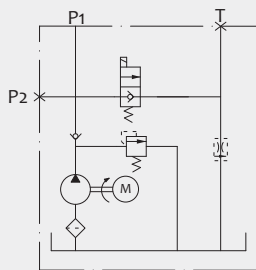

Special Notes

- This type of power unit works at S3 duty cycle, i.e., intermittent duty, 30 seconds on-load and 270 seconds off-load.
- Clean all the hydraulic parts concerned before mounting the power unit.
- Viscosity of the hydraulic oil should be 15–68 cst, which should also be clean and free of impurities. N46 hydraulic oil is recommended.
- Check the oil level in the tank after the initial operation of the power unit.
- Oil changing is required after the initial 100 operation hours, afterwards once every 3000 hours.

Outline Dimension

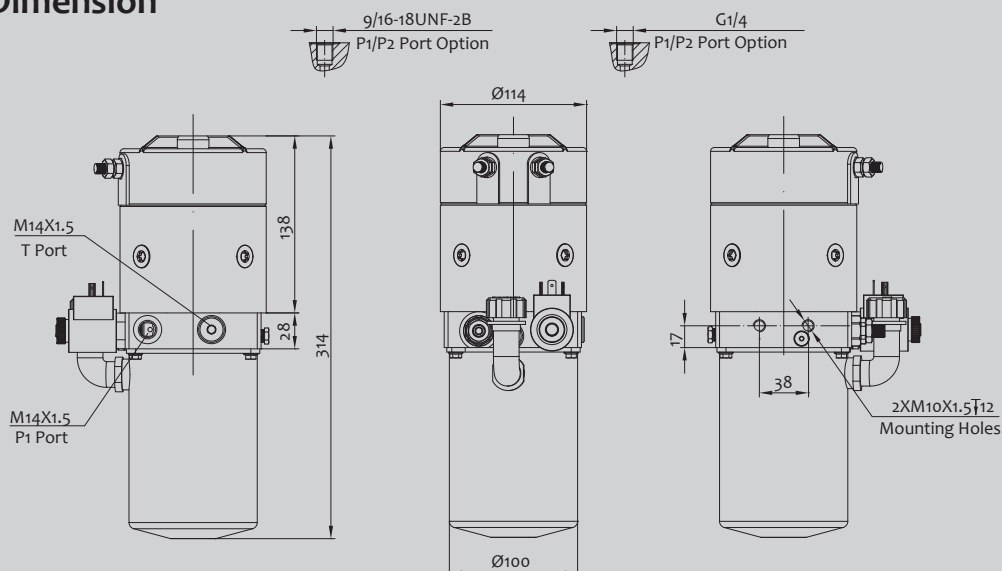

Model Specifications

Model	Motor Voltage	Motor Power	Rated Speed	Displacement	System Pressure	Tank Capacity	Solenoid Valve Voltage
YBZ5-E1.0W2V2/WUTBT1	24VDC	1.3KW	2500RPM	1mL/r	16MPa	1L	24VDC
YBZ5-F0.75Y2V2/WUTBT1				0.75mL/r	20MPa	1.5L	

Remark: Please go to page 1 or consult our sales engineer for the different pump displacement, motor power or system pressure.

POWER UNITS FOR DOCK LEVELER 1

General Description

- High Pressure Gear Pump/ AC Motor/Multi-functional Manifold/Valve/Tank
- The Lowering Speed of Ramp and Lip is Adjusted by the Flow Control Valve

Hydraulic Circuit Diagram

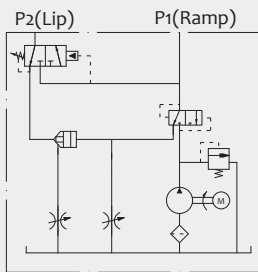

Special Notes

- This type of power unit works at S3 duty cycle, i.e., intermittent duty, 1 minute on-load and 9 minutes off-load.
- Clean all the hydraulic parts concerned before mounting the power unit.
- Viscosity of the hydraulic oil should be 15~68 cst, which should also be clean and free of impurities. N46 hydraulic oil is recommended.
- Check the oil level in the tank after the initial operation of the power unit.
- Oil changing is required after the initial 100 operation hours, afterwards once every 3000 hours.

Outline Dimension

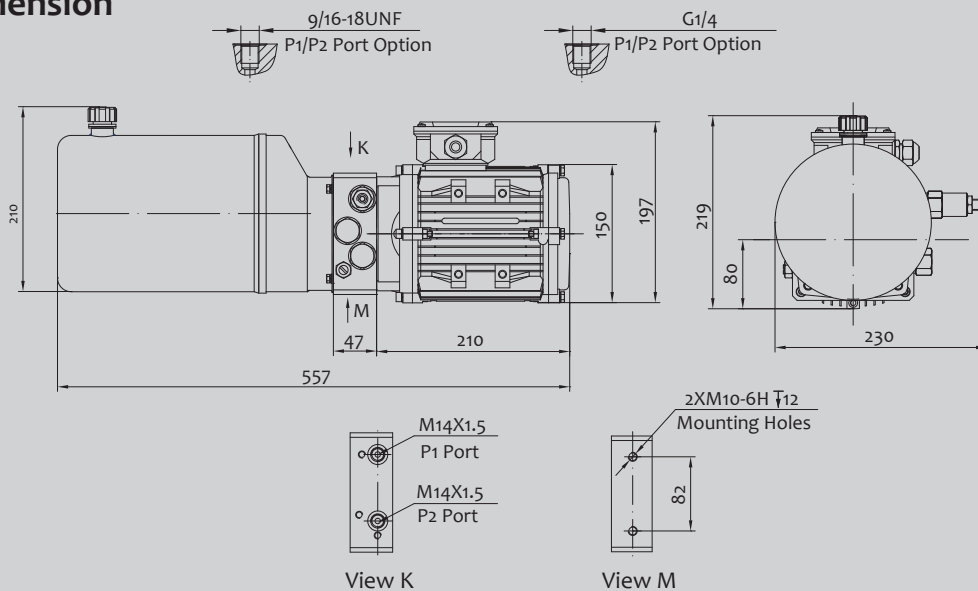

Model Specifications

Model	Motor Voltage	Motor Power	Rated Speed	Displacement	System Pressure	Tank Capacity	Dimensions
YBZ5-E2.1B4E80/LBAOT1	380VAC	0.75KW	1450RPM	2.1mL/r	16MPa	6L	557mm
YBZ5-E2.7B4E80/LBAOT1				2.7mL/r	14MPa		

Remark: Please go to page 1 or consult our sales engineer for the different pump displacement, motor power or system pressure.

POWER UNITS FOR DOCK LEVELER 2

General Description

- High Pressure Gear Pump/ AC Motor/Multi-functional Manifold/Valve/Tank
- Normally Closed Solenoid Operated Lowering Valve
- The Lowering Speed of Ramp and Lip is Adjusted by the Flow Control Valve

Hydraulic Circuit Diagram

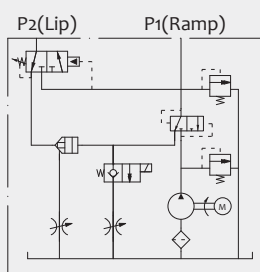

Special Notes

- This type of power unit works at S3 duty cycle, i.e., intermittent duty, 1 minute on-load and 9 minutes off-load.
- Clean all the hydraulic parts concerned before mounting the power unit.
- Viscosity of the hydraulic oil should be 15~68 cst, which should also be clean and free of impurities. N46 hydraulic oil is recommended.
- Check the oil level in the tank after the initial operation of the power unit.
- Oil changing is required after the initial 100 operation hours, afterwards once every 3000 hours.

Outline Dimension

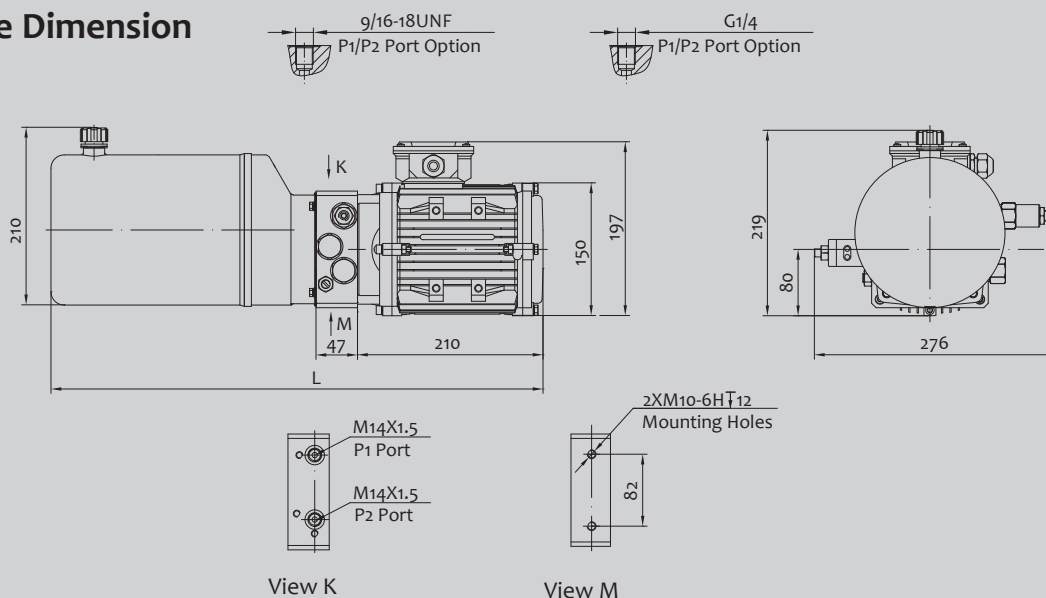

Model Specifications

Model	Motor Voltage	Motor Power	Rated Speed	Displacement	System Pressure	Tank Capacity	Solenoid Valve Voltage
YBZ5-E3.2B4F82/LBAPT1	380VAC	1.1KW	1450RPM	3.2mL/r	16MPa	6L	24VDC
YBZ5-E2.7B4E82/LBAPT1		0.75KW		2.7mL/r	14MPa		

Remark: Please go to page 1 or consult our sales engineer for the different pump displacement, motor power or system pressure.

POWER UNITS FOR DOCK LEVELER 3

General Description

- High Pressure Gear Pump/AC Motor/Multi-functional Manifold/Valve/Tank
- The 3-Way,2-Position Solenoid Valve/The 4-Way,2-Position Solenoid Valve
- The Lowering Speed of Ramp is Adjusted by an One-way Flow Control Valve

Hydraulic Circuit Diagram

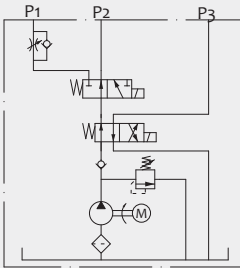

Special Notes

- This type of power unit works at S3 duty cycle, i.e., intermittent duty, 1 minute on-load and 9 minutes off-load.
- Clean all the hydraulic parts concerned before mounting the power unit.
- Viscosity of the hydraulic oil should be 15~68 cst, which should also be clean and free of impurities. N46 hydraulic oil is recommended.
- Check the oil level in the tank after the initial operation of the power unit.
- Oil changing is required after the initial 100 operation hours, afterwards once every 3000 hours.

Outline Dimension

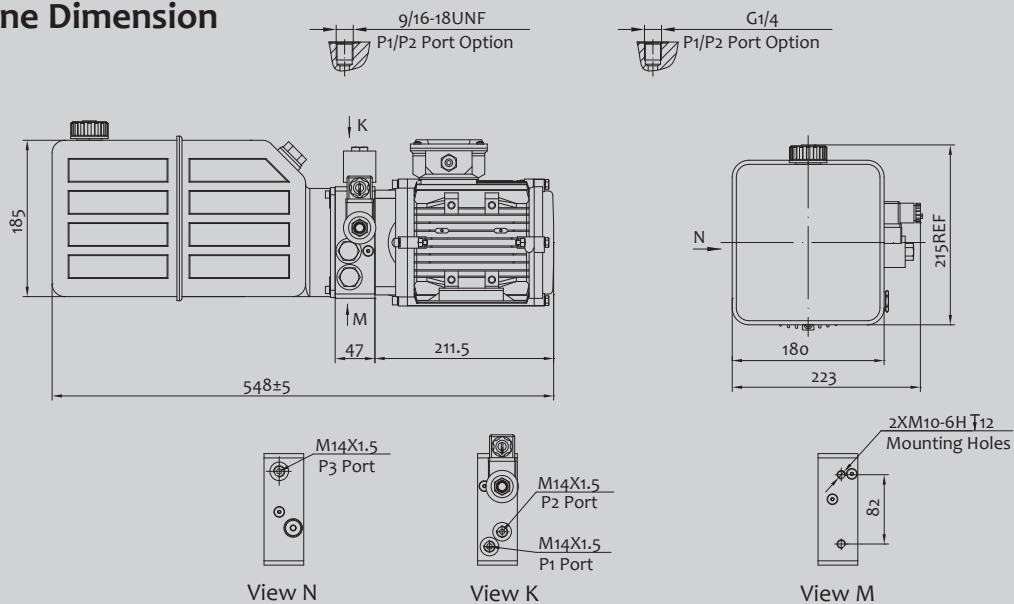

Model Specifications

Model	Motor Voltage	Motor Power	Rated Speed	Displacement	System Pressure	Tank Capacity	Solenoid Valve Voltage
YBZ5-E2.7B4E180/MBUCT1	220/380VAC	0.75KW	1450RPM	2.7mL/r	16MPa	5L	24VAC
YBZ5-E2.7B4F180/MBUCT1		1.1KW			14MPa		

Remark: Please go to page 1 or consult our sales engineer for the different pump displacement, motor power or system pressure.

POWER UNITS FOR DOCK LEVELER 4

General Description

- High Pressure and Low Noise Gear Pump/Oil-immersed and Low Noise AC Motor/Multi-functional Manifold/-Valve/Tank
- Normally Opened Solenoid Operated Lowering Valve
- The Lowering Speed of Ramp is Adjusted by the Flow Control Valve

Hydraulic Circuit Diagram

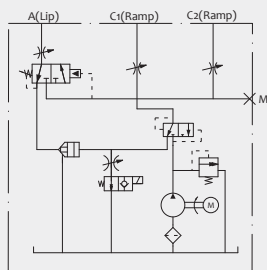

Special Notes

- This type of power unit works at S3 duty cycle, i.e., intermittent duty, 1 minute on-load and 9 minutes off-load.
- Clean all the hydraulic parts concerned before mounting the power unit.
- Viscosity of the hydraulic oil should be 15~68 cst, which should also be clean and free of impurities. N46 hydraulic oil is recommended.
- Check the oil level in the tank after the initial operation of the power unit.
- Oil changing is required after the initial 100 operation hours, afterwards once every 3000 hours.

Outline Dimension

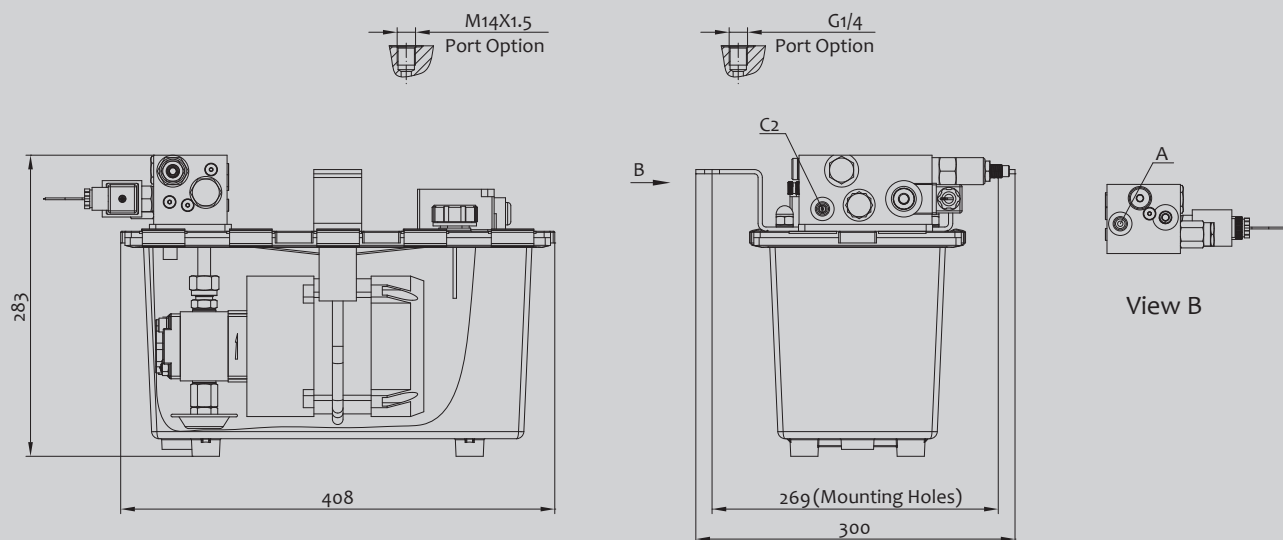

Model Specifications

Model	Motor Voltage	Motor Power	Rated Speed	Displacement	System Pressure	Tank Capacity	Solenoid Valve Voltage
YBZY-D3.2A4E81/TBTB01	380VAC	0.75KW	1450RPM	3.2mL/r	13MPa	4L	24VDC
YBZY-D2.1A4E81/TBTB01				2.1mL/r			

Remark: Please go to page 1 or consult our sales engineer for the different pump displacement, motor power or system pressure.

AUTO HOIST POWER UNITS 1

General Description

- High Pressure Gear Pump/AC Motor/Multi-functional Manifold/Valve/Tank
- Normally Closed Manual Operated Lowering Valve

Hydraulic Circuit Diagram

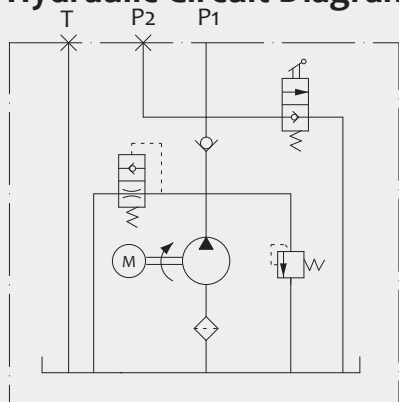

Special Notes

- This type of power unit works at S3 duty cycle, i.e., intermittent duty, 1 minute on-load and 9 minutes off-load.
- Clean all the hydraulic parts concerned before mounting the power unit.
- Viscosity of the hydraulic oil should be 15–68 cst, which should also be clean and free of impurities. N46 hydraulic oil is recommended.
- Check the oil level in the tank after the initial operation of the power unit.
- Oil changing is required after the initial 100 operation hours, afterwards once every 3000 hours.

Outline Dimension

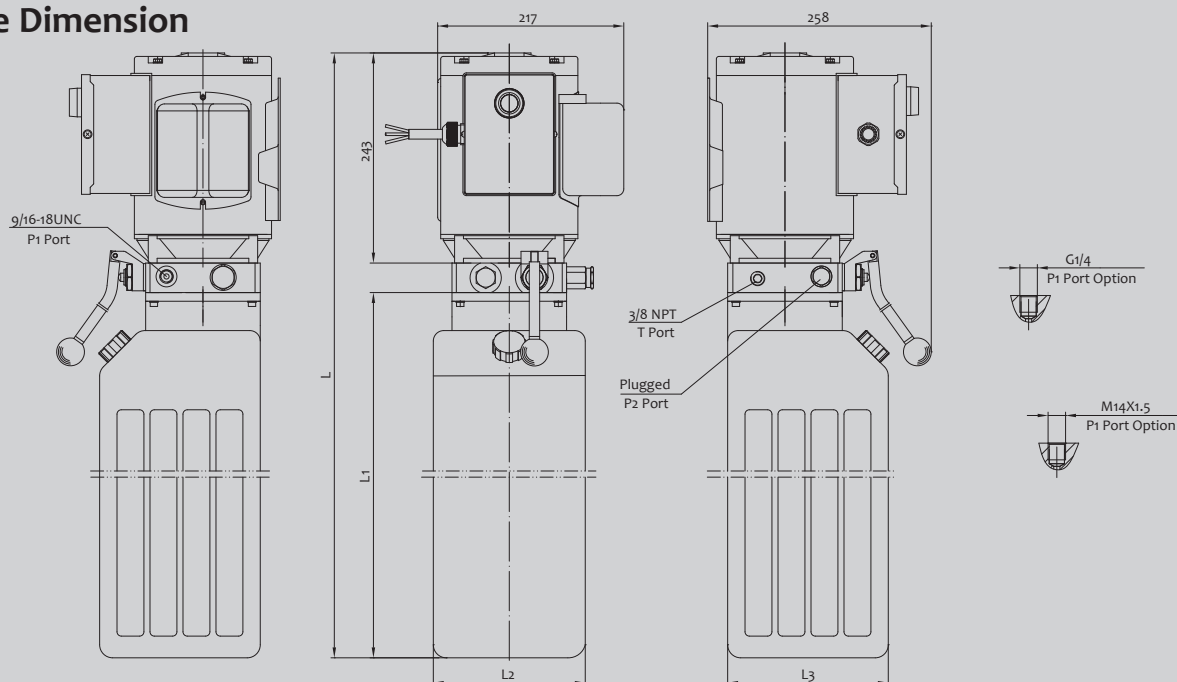

Model Specifications

Model	Motor Voltage	Motor Power	Displacement	System Pressure	Rated Speed	Tank Capacity	Dimensions				Certification
							L1(mm)	L2(mm)	L3(mm)	L(mm)	
YBZ5-Fo.8B5F1/ALVOT1	115V 60Hz	1.1KW	0.8ml/r	20MPa	3450RPM	6L	335	180	180	611	CE
YBZ5-Fo.8C5F1/ALVOT1						8L	440			716	
YBZ5-E1.2B5F1/ALVOT1			1.2ml/r	17.5MPa		6L	335			611	
YBZ5-E1.2C5F1/ALVOT1						8L	440			716	
YBZ5-Fo.8B8F1/AMVOT1	115/230V 50/60Hz		0.8ml/r	20MPa	2830/3450RPM	6L	335			611	
YBZ5-Fo.8C8F1/AMVOT1						8L	440			716	
YBZ5-E1.2B8F1/AMVOT2			1.2ml/r	17.5MPa		6L	335			611	
YBZ5-E1.2C8F1/AMVOT1						8L	440			716	
YBZ5-F2.1E3H1/AMQOT1	208-240V 50/60Hz	2.2KW	2.1ml/r	20MPa	2830/3450RPM	12L	540	165	185	816	
YBZ5-F2.1F3H1/AMQOT1	230/460V 60Hz					14L	600	175	185	876	
YBZ5-F2.1E7H1/ALQOT1					3450RPM	12L	540	165	185	816	
YBZ5-F2.1F7H1/ALQOT1	14L					600	175	185	876		
YBZ5-F2.1E20H1/AMQOT1	190/ 208-240/ 380/460V 50/60Hz		2.5ml/r	17.5MPa	2830/3450RPM	12L	540	165	185	816	
YBZ5-F2.5F20H1/AMQOT1						14L	600	175	185	876	
YBZ5-E4.2E20H1/ANQOT1			4.2ml/r		1450/1725RPM	12L	540	165	185	816	
YBZ5-E4.2F20H1/ANQOT1						14L	600	175	185	876	
YBZ5-Fo.8B8F1/AMQOT4	115/230V 50/60Hz	1.1KW	0.8ml/r	20MPa	2830/3450RPM	6L	335	180	180	611	ETL
YBZ5-F2.1F3H1/AMQOT4	220V 50/60Hz	2.2KW	2.1ml/r	14L		600	175	185	876		
YBZ5-F2.1F3H1/ALQOT1	220V 60Hz	2.2KW	2.1ml/r	20MPa	3450RPM	14L	600	175	185	876	UL
YBZ5-E2.1F3H1/ALQOT1				17.5MPa							

Remark: Please go to page 1 or consult our sales engineer for the different pump displacement, motor power or system pressure.

AUTO HOIST POWER UNITS 2

General Description

- High Pressure Gear Pump/AC Motor/Multi-functional Manifold/Valve/Tank
- Normally Closed Solenoid Operated Lowering Valve
- The Lowering Speed is Adjusted by the Pressure Compensated Flow Control Valve

Hydraulic Circuit Diagram

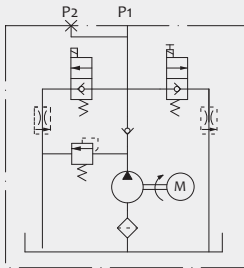

Special Notes

- This type of power unit works at S3 duty cycle, i.e., intermittent duty, 1 minute on-load and 9 minutes off-load.
- Clean all the hydraulic parts concerned before mounting the power unit.
- Viscosity of the hydraulic oil should be 15~68 cst, which should also be clean and free of impurities. N46 hydraulic oil is recommended.
- Check the oil level in the tank after the initial operation of the power unit.
- Oil changing is required after the initial 100 operation hours, afterwards once every 3000 hours.

Outline Dimension

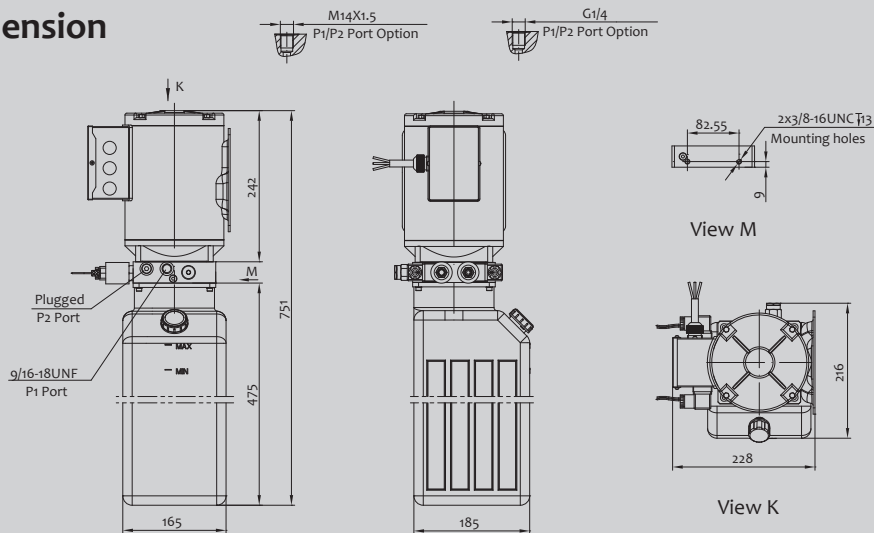

Model Specifications

Model	Motor Voltage	Motor Power	Rated Speed	Displacement	System Pressure	Tank Capacity	Solenoid Valve Voltage
YBZ5-F2.7D4H202/ACQIT1	380VAC	2.2KW	2850RPM	2.7mL/r	20MPa	10L	24VDC
YBZ5-F2.7D4H202/ACDIT1				3.2mL/r	16MPa		
YBZ5-E3.2D3H202/LCQIT1	220VAC	3KW	3500RPM	2.7mL/r	20MPa	10L	24VDC
YBZ5-F2.7D2B202/XVQIT1	24VDC			3.2mL/r	16MPa		

Remark: Please go to page 1 or consult our sales engineer for the different pump displacement, motor power or system pressure.

AUTO HOIST POWER UNITS 3

General Description

- High Pressure Gear Pump/AC Motor/Multi-functional Manifold/Valve/Tank
- The Lowering Speed is Adjusted by the Flow Control Valve

Hydraulic Circuit Diagram

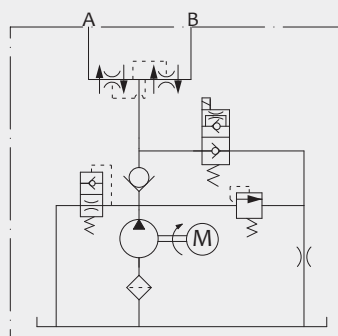

Special Notes

- This type of power unit works at S3 duty cycle, i.e., intermittent duty, 1 minute on-load and 9 minutes off-load.
- Clean all the hydraulic parts concerned before mounting the power unit.
- Viscosity of the hydraulic oil should be 15~68 cst, which should also be clean and free of impurities. N46 hydraulic oil is recommended.
- Check the oil level in the tank after the initial operation of the power unit.
- Oil changing is required after the initial 100 operation hours, afterwards once every 3000 hours.

Outline Dimension

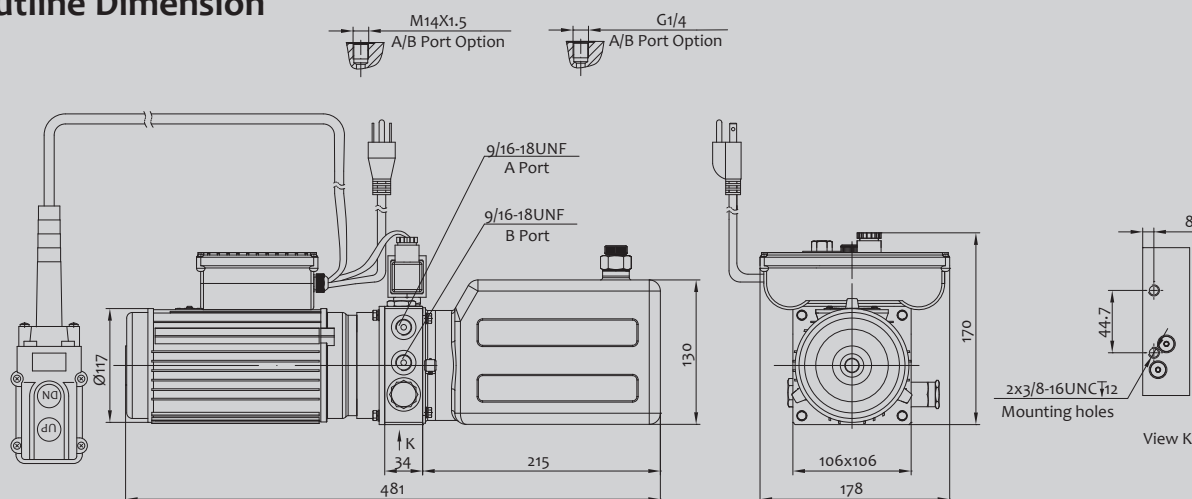

Model Specifications

Model	Motor Voltage	Motor Power	Rated Speed	Displacement	System Pressure	Tank Capacity	Solenoid Valve Voltage
YBZ5-Eo.6Z23D195/TMXFT2	100VAC	550W	2850/3450RPM	0.6mL/r	24MPa	2L	110VAC
YBZ5-Eo.6Z5D195/TLXFT2	110VAC		3450RPM				
YBZ5-Eo.6Z3D195/TMXCT2K	220VAC		2850/3450RPM				24VAC
YBZ5-Eo.6Z3D195/TMXCT2							
YBZ5-Fo.38Z1T195/VUXAT2A	12VDC	800W	2500RPM	0.38mL/r	26.5MPa		12VDC

Remark: Please go to page 1 or consult our sales engineer for the different pump displacement, motor power or system pressure.

POWER UNITS FOR LIFT TABLE 1

General Description

- High Pressure Gear Pump/AC Motor/Multi-functional Manifold/Valve/Tank
- Normally Closed Solenoid Operated Lowering Valve
- The Lowering Speed is Adjusted by the Flow Control Valve

Hydraulic Circuit Diagram

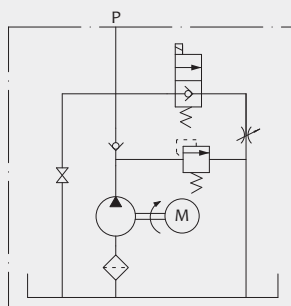

Special Notes

- This type of power unit works at S3 duty cycle, i.e., intermittent duty, 1 minute on-load and 9 minutes off-load.
- Clean all the hydraulic parts concerned before mounting the power unit.
- Viscosity of the hydraulic oil should be 15–68 cst, which should also be clean and free of impurities. N46 hydraulic oil is recommended.
- Check the oil level in the tank after the initial operation of the power unit.
- Oil changing is required after the initial 100 operation hours, afterwards once every 3000 hours.

Outline Dimension

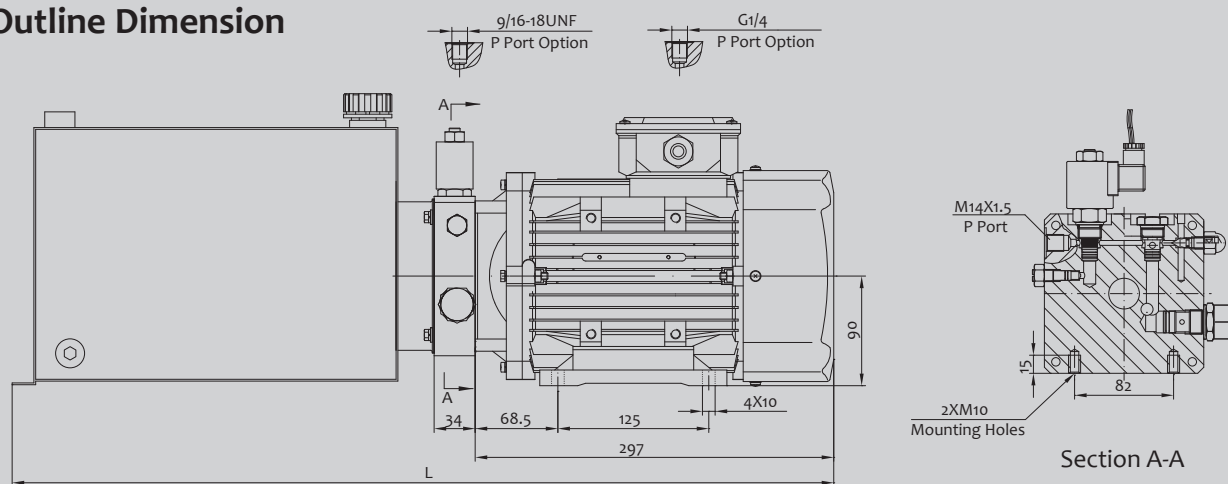

Model Specifications

Model	Motor Voltage	Motor Power	Rated Speed	Displacement	System Pressure	Tank Capacity	Solenoid Valve Voltage
YBZ5-F2.5E3H2/LCCAG1	220VAC	2.2KW	2850RPM	2.5mL/r	18MPa	12L	12VDC
YBZ5-E3.2F3H2/LCCBG1				14MPa	14L	24VDC	
YBZ5-D3.7G3H2/LCCCG1				12MPa	16L	24VAC	
YBZ5-E3.7G412/LCCDG1	380VAC	3KW		3.7mL/r	16MPa	16L	110VAC
YBZ5-E4.2H412/LCCEG1				15MPa	20L	220VAC	
YBZ5-D5J412/LCCEG1				12MPa	25L	220VAC	

Remark: Please go to page 1 or consult our sales engineer for the different pump displacement, motor power or system pressure.

POWER UNITS FOR LIFT TABLE 2

General Description

- High Pressure Gear Pump/AC Motor/Multi-functional Manifold/Valve/Tank
- Normally Closed Solenoid Operated Lowering Valve
- The Lowering Speed is Adjusted by the Flow Control Valve

Hydraulic Circuit Diagram

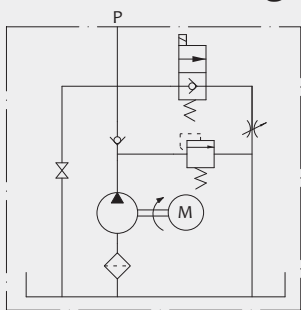

Special Notes

- This type of power unit works at S3 duty cycle, i.e., intermittent duty, 1 minute on-load and 9 minutes off-load.
- Clean all the hydraulic parts concerned before mounting the power unit.
- Viscosity of the hydraulic oil should be 15–68 cst, which should also be clean and free of impurities. N46 hydraulic oil is recommended.
- Check the oil level in the tank after the initial operation of the power unit.
- Oil changing is required after the initial 100 operation hours, afterwards once every 3000 hours.

Outline Dimension

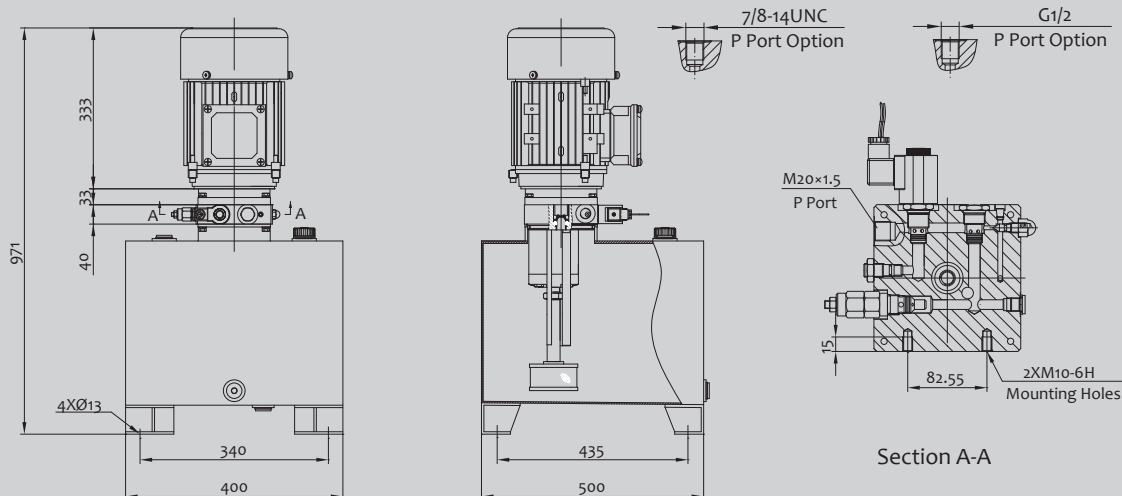

Model Specifications

Model	Motor Voltage	Motor Power	Rated Speed	Displacement	System Pressure	Tank Capacity	Solenoid Valve Voltage
LPU-E15P4J2/TKDAZ1	380VAC	4KW	1750RPM	15.92mL/r	16MPa	80L	12VDC
LPU-E15P4K2/TKDBZ1		5.5KW		23.27mL/r	14MPa		24VDC
LPU-E23P4K2/TKDDZ1				28.05mL/r	12MPa		110VAC
LPU-D28P4K2/TKDEZ1							

Remark: Please go to page 1 or consult our sales engineer for the different pump displacement, motor power or system pressure.

POWER UNITS FOR DUBBLE-SCISSORS LIFT 1

General Description

- Gear Pump/ AC Motor/Multi-functional Manifold/Valve/Tank
- Two-way Shut-off Valve
- The Lowering Speed is Adjusted by the Pressure Compensated Flow Control Valve

Hydraulic Circuit Diagram

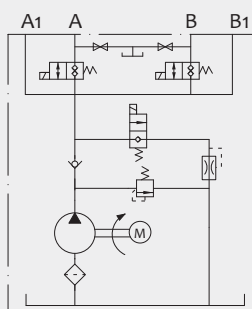

Special Notes

- This type of power unit works at S3 duty cycle, i.e., intermittent duty, 1 minute on-load and 9 minutes off-load.
- Clean all the hydraulic parts concerned before mounting the power unit.
- Viscosity of the hydraulic oil should be 15–68 cst, which should also be clean and free of impurities. N46 hydraulic oil is recommended.
- Check the oil level in the tank after the initial operation of the power unit.
- Oil changing is required after the initial 100 operation hours, afterwards once every 3000 hours.

Outline Dimension

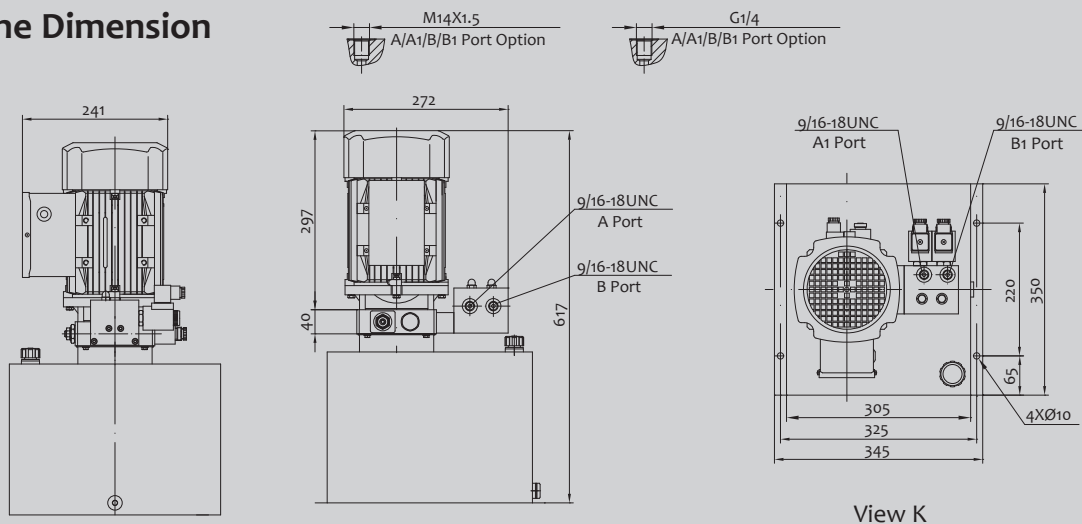

Model Specifications

Model	Motor Voltage	Motor Power	Rated Speed	Displacement	System Pressure	Tank Capacity	Solenoid Valve Voltage
YBZ5-F2.7C3G30/LBAAN1	220VAC	1.5KW	1450rpm	2.7mL/r	22MPa	8L	12VDC
YBZ5-F3.2E3G30/LBCAN1					20MPa	12L	
YBZ5-E3.2G3H30/LCCBN1	220VAC	2.2KW	2850rpm	3.2mL/r	15MPa	16L	24VDC
YBZ5-D4.2G3H30/LCCDN1					10MPa		110VAC

Remark: Please go to page 1 or consult our sales engineer for the different pump displacement, motor power or system pressure.

POWER UNITS FOR DUBBLE-SCISSORS LIFT 2

General Description

- Gear Pump/ AC Motor/Multi-functional Manifold/- Valve/Tank
- Two-way Shut-off Valve
- The Lowering Speed is Adjusted by the Flow Control Valve

Hydraulic Circuit Diagram

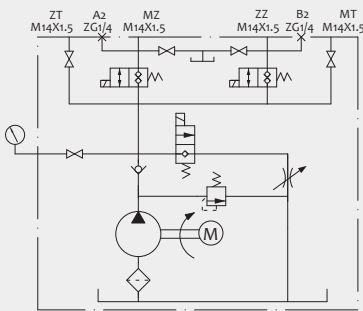

Special Notes

- This type of power unit works at S3 duty cycle, i.e., intermittent duty, 1 minute on-load and 9 minutes off-load.
- Clean all the hydraulic parts concerned before mounting the power unit.
- Viscosity of the hydraulic oil should be 15~68 cst, which should also be clean and free of impurities. N46 hydraulic oil is recommended.
- Check the oil level in the tank after the initial operation of the power unit.
- Oil changing is required after the initial 100 operation hours, afterwards once every 3000 hours.

Outline Dimension

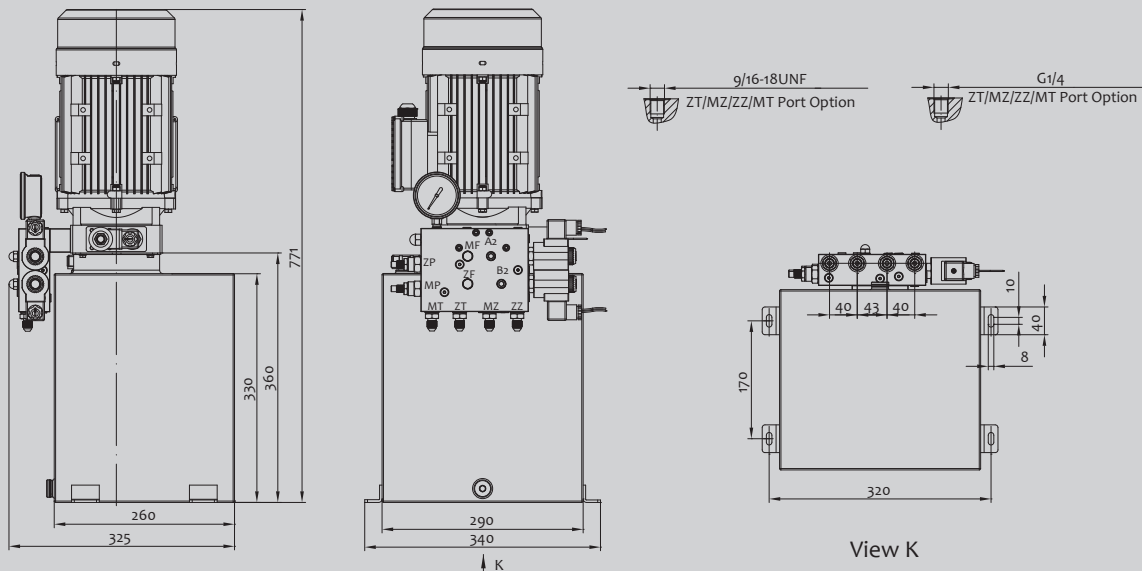

Model Specifications

Model	Motor Voltage	Motor Power	Rated Speed	Displacement	System Pressure	Tank Capacity	Solenoid Valve Voltage
YBZ5-G2.1J3H30E/MCDBN2	220VAC	2.2KW	2800 RPM	2.1mL/r	25MPa	25L	24VDC
YBZ5-G2.5J4H30E/MCDEN2	380VAC			2.5mL/r			220VAC

Remark: Please go to page 1 or consult our sales engineer for the different pump displacement, motor power or system pressure.

POWER UNITS FOR SCISSOR LIFT

General Description

- Gear Pump/ AC Motor/Multi-functional Manifold/Valve/Tank
- Normally Closed Solenoid Operated Lowering Valve
- The Lowering Speed is Adjusted by the Flow Control Valve

Hydraulic Circuit Diagram

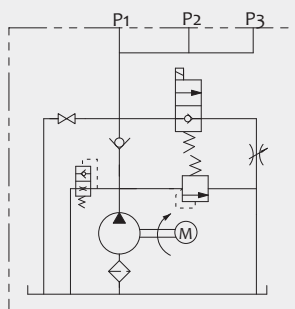

Special Notes

- This type of power unit works at S3 duty cycle, i.e., intermittent duty, 1 minute on-load and 9 minutes off-load.
- Clean all the hydraulic parts concerned before mounting the power unit.
- Viscosity of the hydraulic oil should be 15–68 cst, which should also be clean and free of impurities. N46 hydraulic oil is recommended.
- Check the oil level in the tank after the initial operation of the power unit.
- Oil changing is required after the initial 100 operation hours, afterwards once every 3000 hours.

Outline Dimension

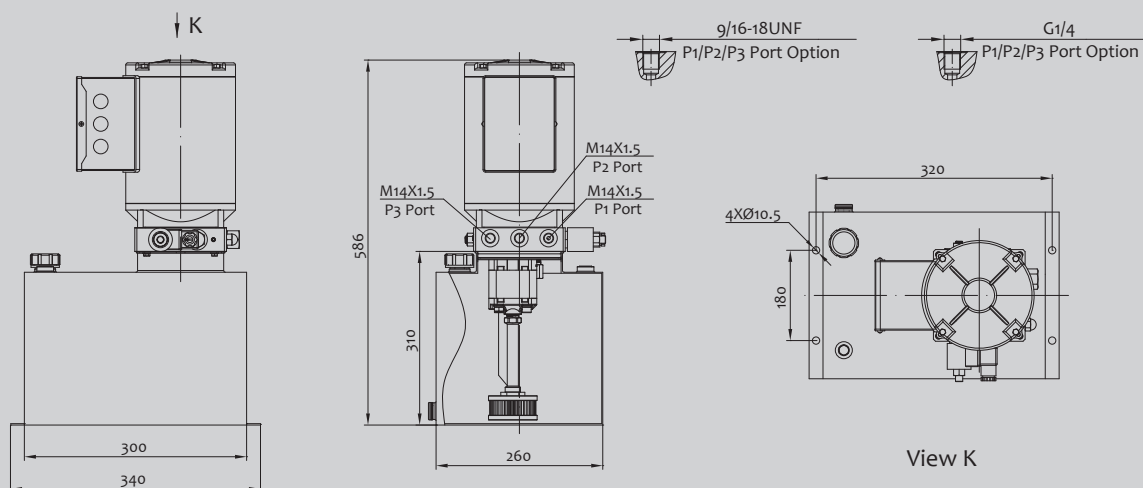

Model Specifications

Model	Motor Voltage	Motor Power	Rated Speed	Displacement	System Pressure	Tank Capacity	Solenoid Valve Voltage
YBZ5-F2.1H4H2/BCDBT1	380VAC	2.2KW	2850RPM	2.1mL/r	23MPa	20L	24VDC
YBZ5-G2.5H4I2/BCDBT1		3KW		2.5mL/r	25MPa		
YBZ5-G2.5G3I2/ACDBT1	220VAC				16L		

Remark: Please go to page 1 or consult our sales engineer for the different pump displacement, motor power or system pressure.

ELECTRIC-BASKETBALL STANDS POWER UNITS

General Description

- High Pressure Gear Pump/AC Motor/Multi-functional Manifold/Valve/Tank
 - The 4-Way,3-Position Solenoid Valve
- The Lowering Speed is Adjusted by the Pressure
- Compensated Flow Control Valve

Hydraulic Circuit Diagram

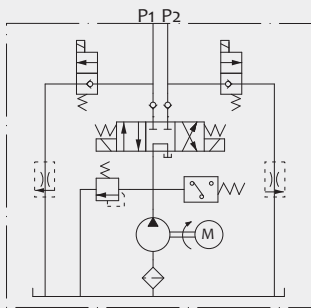

Special Notes

- This type of power unit works at S3 duty cycle, i.e.,intermittent duty,1 minute on-load and 9 minutes off-load.
- Clean all the hydraulic parts concerned before mounting the power unit.
- Viscosity of the hydraulic oil should be 15~68 cst,which should also be clean and free of impurities.N46 hydraulic oil is recommended.
- Check the oil level in the tank after the initial operation of the power unit.
- Oil changing is required after the initial 100 operation hours,afterwards once every 3000 hours.

Outline Dimension

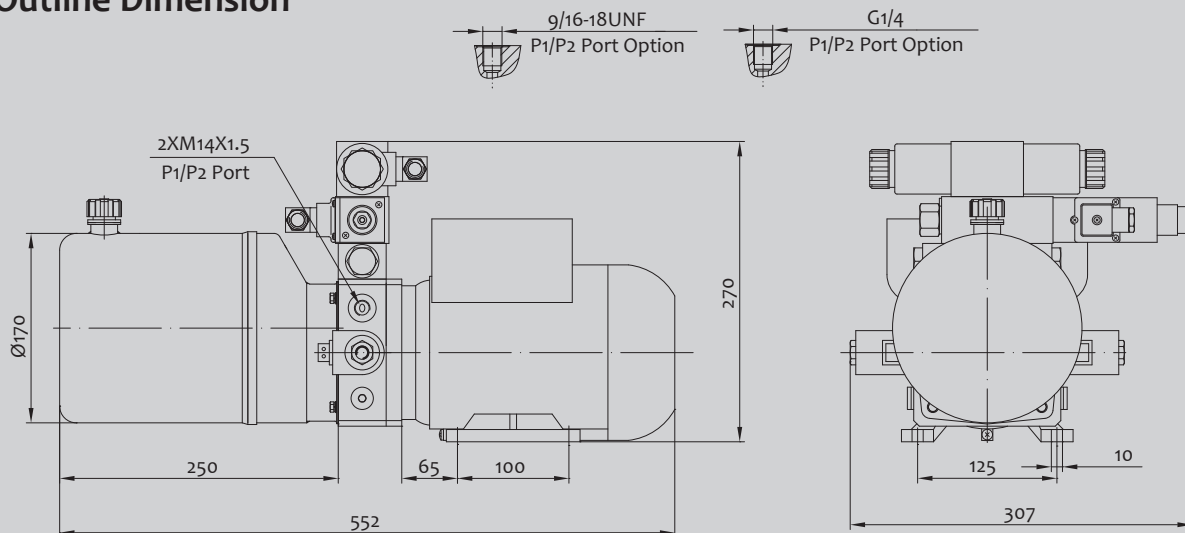

Model Specifications

Model	Motor Voltage	Motor Power	Rated Speed	Displacement	System Pressure	Tank Capacity	Solenoid Valve Voltage
YBZ5-F1.6B3E42/1	220VAC	0.75KW	1450RPM	1.6ml/r	20MPa	5L	24VDC
YBZ5-E3.7B3G42/1		1.5KW		3.7ml/r	18MPa		

Remark: Please go to page 1 or consult our sales engineer for the different pump displacement, motor power or system pressure.

POWER UNIT FOR TIRE CHANGER

General Description

- High Pressure Gear Pump/AC Motor/Multi-functional Manifold/Valve/Tank
- The 4-Way,3-Position Solenoid Valve

Hydraulic Circuit Diagram

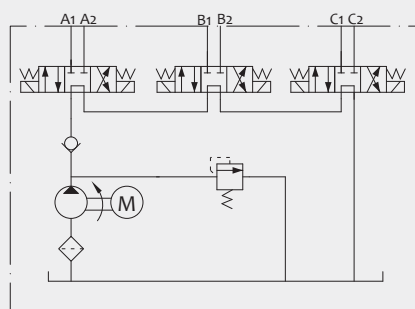

Special Notes

- This type of power unit works at S3 duty cycle, i.e.,intermittent duty,1 minute on-load and 9 minutes off-load.
- Clean all the hydraulic parts concerned before mounting the power unit.
- Viscosity of the hydraulic oil should be 15~68 cst,which should also be clean and free of impurities.N46 hydraulic oil is recommended.
- Check the oil level in the tank after the initial operation of the power unit.
- Oil changing is required after the initial 100 operation hours,afterwards once every 3000 hours.

Outline Dimension

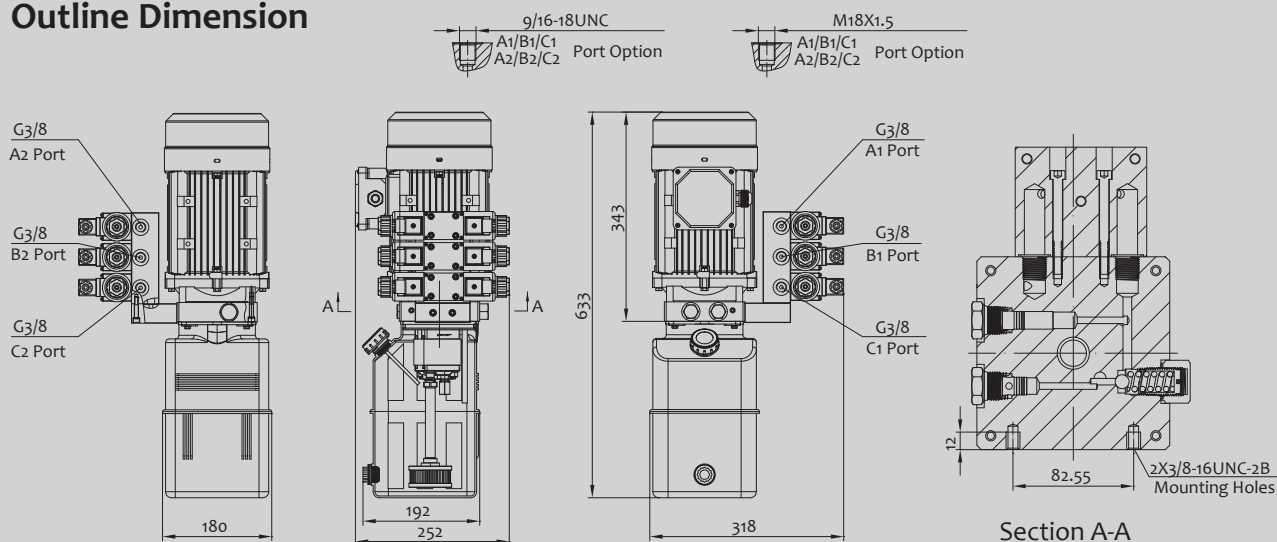

Model Specifications

Model	Motor Voltage	Motor Power	Rated Speed	Displacement	System Pressure	Tank Capacity	Solenoid Valve Voltage
YBZ5-F2.7B4G40/MNVBE1	380VAC	1.5KW	1430RPM/ 1750RPM	2.7ml/r	20MPa	5L	24VDC
YBZ5-F2.5B4G40/MNVBE1				2.5ml/r		6L	
YBZ5-F2.1C4G40/MNVAE1				2.1ml/r		8L	

Remark: Please go to page 1 or consult our sales engineer for the different pump displacement, motor power or system pressure.

TIPPER TRAILER POWER UNITS 1

General Description

- High Pressure Gear Pump/ Low Noise DC Motor/- Multi-functional Manifold/Valve/Tank
- Normally Closed Solenoid Operated Lowering Valve

Hydraulic Circuit Diagram

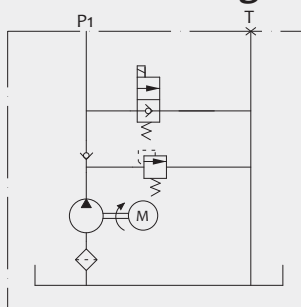

Special Notes

- This type of power unit works at S3 duty cycle, i.e., intermittent duty, 30 seconds on-load and 270 seconds off-load.
- Clean all the hydraulic parts concerned before mounting the power unit.
- Viscosity of the hydraulic oil should be 15–68 cst, which should also be clean and free of impurities. N46 hydraulic oil is recommended.
- Check the oil level in the tank after the initial operation of the power unit.
- Oil changing is required after the initial 100 operation hours, afterwards once every 3000 hours.

Outline Dimension

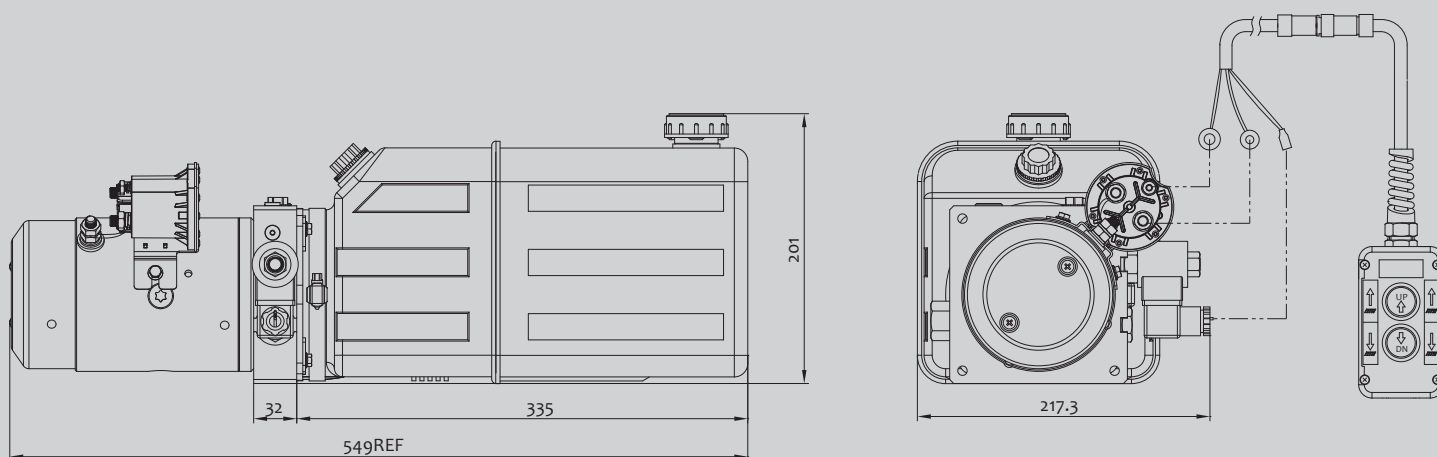

Model Specifications

Model	Motor Voltage	Motor Power	Rated Speed	Displacement	System Pressure	Tank Capacity	Solenoid Valve Voltage
YBZ5-F2.1B1W2/WUUAT1	12VDC	1.5KW	2500rpm	2.1mL/r	20MPa	6L	12VDC
YBZ5-F2.1A1W2/WUUAT1				2.5mL/r		4L	
YBZ5-F2.5E2A2/WUCBD1/RC	24VDC	2.0KW		2.5mL/r		12L	24VDC
YBZ5-F2.7G2A2/WUABD1/RC				2.7mL/r		16L	

Remark: Please go to page 1 or consult our sales engineer for the different pump displacement, motor power or system pressure.

TIPPER TRAILER POWER UNITS 2

General Description

- High Pressure Gear Pump/ Low Noise DC Motor/- Multi-functional Manifold/Valve/Tank
- The 4-Way,2-Position Solenoid Valve
- The Lowering Speed is Adjusted by the Pressure Compensated Flow Control Valve

Hydraulic Circuit Diagram

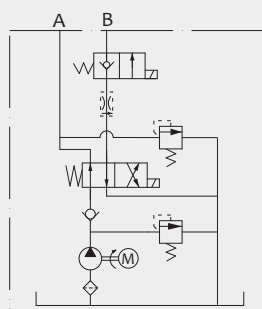

Special Notes

- This type of power unit works at S3 duty cycle, i.e.,intermittent duty,30 seconds on-load and 270 seconds off-load.
- Clean all the hydraulic parts concerned before mounting the power unit.
- Viscosity of the hydraulic oil should be 15–68 cst,which should also be clean and free of impurities.N46 hydraulic oil is recommended.
- Check the oil level in the tank after the initial operation of the power unit.
- Oil changing is required after the initial 100 operation hours,afterwards once every 3000 hours.

Outline Dimension

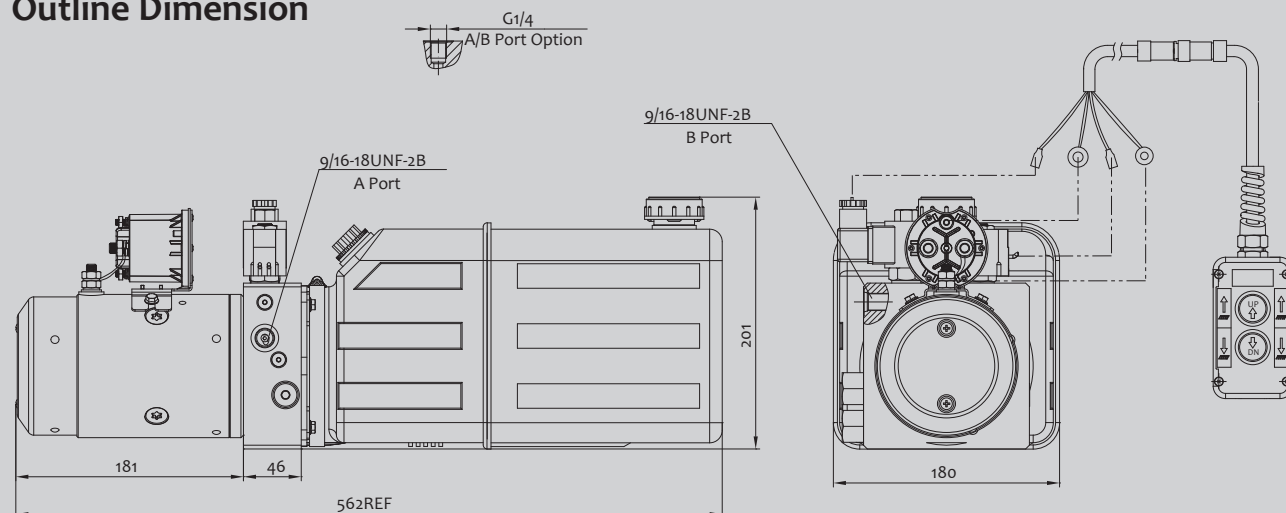

Model Specifications

Model	Motor Voltage	Motor Power	Rated Speed	Displacement	System Pressure	Tank Capacity	Solenoid Valve Voltage
YBZ5-F2.1B1A61/WUUAT1	12VDC	2.0KW	2500RPM	2.1mL/r	20MPa	6L	12VDC
YBZ5-F2.1B1A61/WUUTT1							10VDC
YBZ5-F2.1B2A61/WUABT1/RC	24VDC			2.7mL/r			24VDC
YBZ5-F2.7B2A61/WUABT1/RC							24VDC

Remark: Please go to page 1 or consult our sales engineer for the different pump displacement, motor power or system pressure.

TIPPER TRAILER POWER UNITS 3

General Description

- High Pressure Gear Pump/DC Motor/Multi-functional Manifold/Valve/Tank
- The 4-Way,2-Position Solenoid Valve

Hydraulic Circuit Diagram

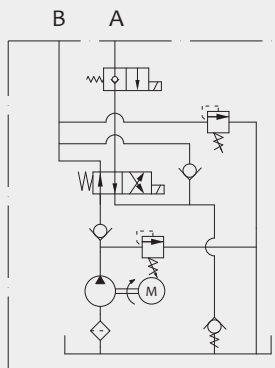

Special Notes

- This type of power unit works at S3 duty cycle, i.e., intermittent duty, 30 seconds on-load and 270 seconds off-load.
- Clean all the hydraulic parts concerned before mounting the power unit.
- Viscosity of the hydraulic oil should be 15–68 cst, which should also be clean and free of impurities. N46 hydraulic oil is recommended.
- Check the oil level in the tank after the initial operation of the power unit.
- Oil changing is required after the initial 100 operation hours, afterwards once every 3000 hours.

Outline Dimension

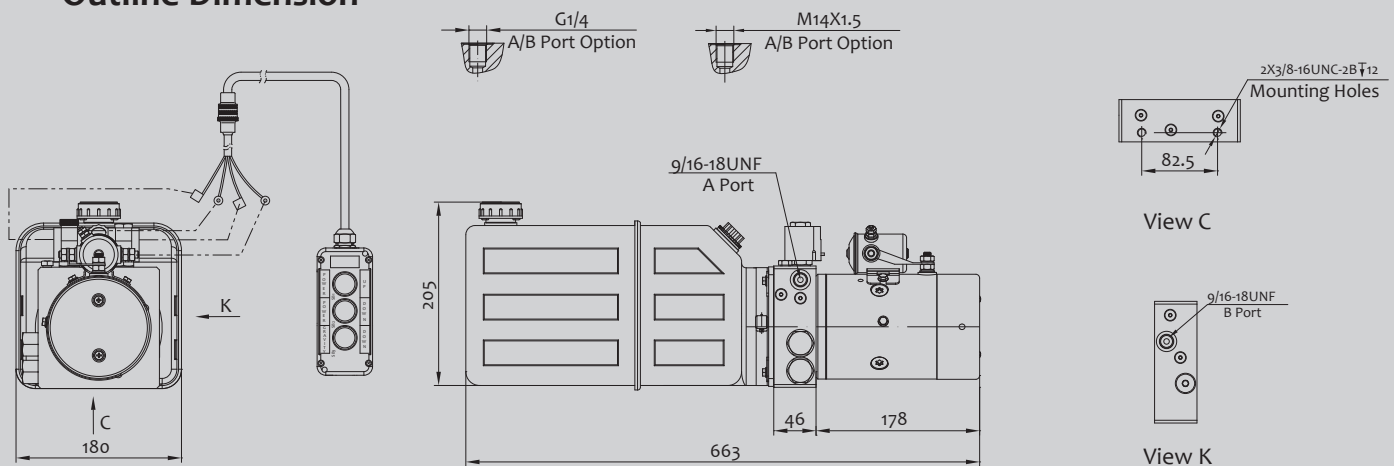

Model Specifications

Model	Motor Voltage	Motor Power	Rated Speed	Displacement	System Pressure	Tank Capacity	Solenoid Valve Voltage
YBZ5-F2.1A1A161/WUUTT1	12VDC	2.0KW	2500RPM	2.1mL/r	22MPa	4L	10VDC
YBZ5-F2.1B1A161/WUUTT1						6L	
YBZ5-F2.1C1A161/WUUTT1						8L	
YBZ5-F2.1A2A161/WUUBT1	24VDC	2.0KW	2500RPM	2.1mL/r	22MPa	4L	24VDC
YBZ5-F2.1B2A161/WUUBT1						6L	
YBZ5-F2.1C2A161/WUUBT1						8L	

Remark: Please go to page 1 or consult our sales engineer for the different pump displacement, motor power or system pressure.

TIPPER TRAILER POWER UNITS 4

General Description

- High Pressure Gear Pump/DC Motor/Multi-functional Manifold/Valve/Tank
- Normally Closed Solenoid Operated Lowering Valve

Hydraulic Circuit Diagram

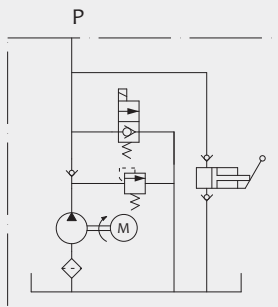

Special Notes

- This type of power unit works at S3 duty cycle, i.e., intermittent duty, 30 seconds on-load and 270 seconds off-load.
- Clean all the hydraulic parts concerned before mounting the power unit.
- Viscosity of the hydraulic oil should be 15–68 cst, which should also be clean and free of impurities. N46 hydraulic oil is recommended.
- Check the oil level in the tank after the initial operation of the power unit.
- Oil changing is required after the initial 100 operation hours, afterwards once every 3000 hours.

Outline Dimension

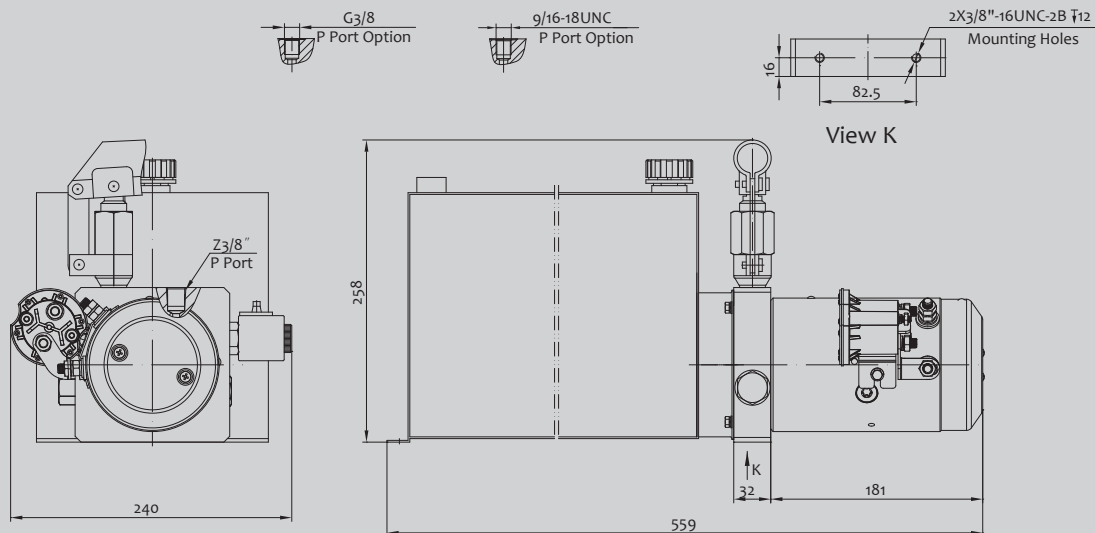

Model Specifications

Model	Motor Voltage	Motor Power	Rated Speed	Displacement	System Pressure	Tank Capacity	Solenoid Valve Voltage
YBZ5-F2.1E1W27/WUCAT1	12VDC	1.5KW	2500rpm	2.1mL/r	20MPa	12L	12VDC
YBZ5-F2.1H1W27/WUCAT1				20L			
YBZ5-F2.5E2A27/WUCBT1	24VDC	2.0KW		2.5mL/r	18MPa	12L	24VDC
YBZ5-F2.7H2A27/WUCBT1				20L			

Remark: Please go to page 1 or consult our sales engineer for the different pump displacement, motor power or system pressure.

POWER UNITS FOR SNOW PLOW

General Description

- High Pressure Gear Pump/DC Motor/Multi-functional Manifold/Valve/Tank
- Dual Pilot-operated Check Valve
- The 3-Way,2-Position Solenoid Valve

Hydraulic Circuit Diagram

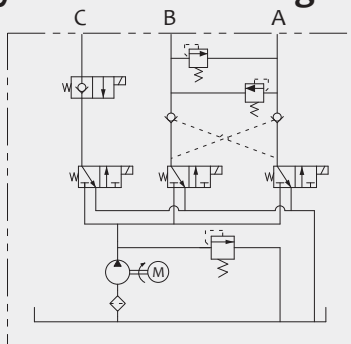

Special Notes

- This type of power unit works at S3 duty cycle, i.e., intermittent duty, 30 seconds on-load and 270 seconds off-load.
- Clean all the hydraulic parts concerned before mounting the power unit.
- Viscosity of the hydraulic oil should be 15–68 cst, which should also be clean and free of impurities. N46 hydraulic oil is recommended.
- Check the oil level in the tank after the initial operation of the power unit.
- Oil changing is required after the initial 100 operation hours, afterwards once every 3000 hours.

Outline Dimension

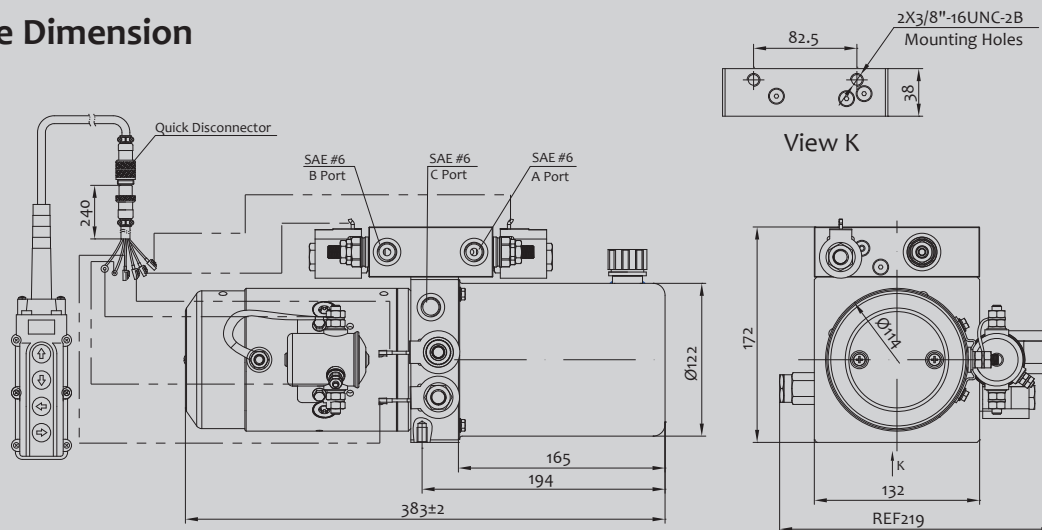

Model Specifications

Model	Motor Voltage	Motor Power	Rated Speed	Displacement	System Pressure	Tank Capacity	Solenoid Valve Voltage
YBZ5 – E1.2Y1W514/WUAAT1	12VDC	1.5KW	2500RPM	1.2ml/r	16MPa	1.5L	12VDC
YBZ5 – E1.6Y1W514/WUAAT1				1.6ml/r			
YBZ5 – E2.1Y2A514/WUAAT1	24VDC	2KW		2.1ml/r			
YBZ5 – E2.5Y2A514/WUAAT1				2.5ml/r			

Remark: Please go to page 1 or consult our sales engineer for the different pump displacement, motor power or system pressure.

WHEEL CHAIR POWER UNITS

General Description

- High Pressure Gear Pump/DC Motor/Multi-functional Manifold/Valve/Tank

Hydraulic Circuit Diagram

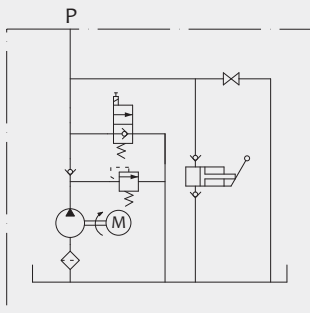

Special Notes

- This type of power unit works at S3 duty cycle, i.e., intermittent duty, 30 seconds on-load and 270 seconds off-load.
- Clean all the hydraulic parts concerned before mounting the power unit.
- Viscosity of the hydraulic oil should be 15–68 cst, which should also be clean and free of impurities. N46 hydraulic oil is recommended.
- Check the oil level in the tank after the initial operation of the power unit.
- Oil changing is required after the initial 100 operation hours, afterwards once every 3000 hours.

Outline Dimension

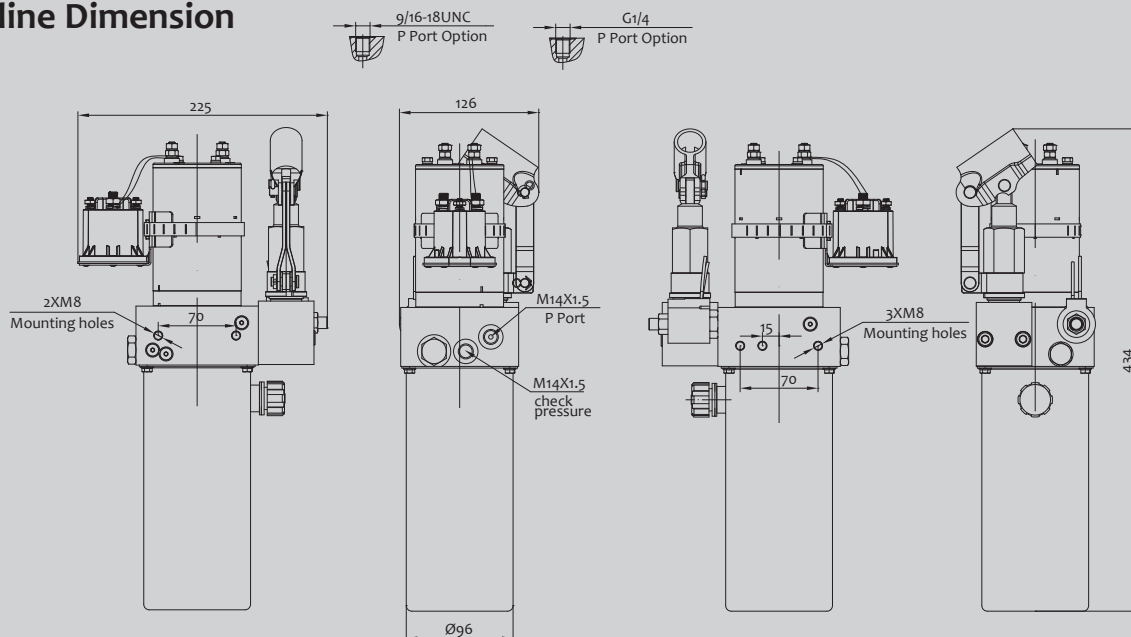

Model Specifications

Model	Motor Voltage	Motor Power	Rated Speed	Displacement	System Pressure	Tank Capacity	Solenoid Valve Voltage
YBZ5-Do.63Y1T48/UVMHK1	12VDC	0.8KW	3500RPM	0.63ml/r	10MPa	1.5L	12VDC
YBZ5-Do.63S1T48/UVKHT1						1.4L	
YBZ5-Do.63S2T48/UVKIT1	24VDC	0.8KW	3500RPM	0.63ml/r	10MPa	1.4L	24VDC
YBZ5-Do.63Y2T48/UVKHK1						1.5L	12VDC

Remark: Please go to page 1 or consult our sales engineer for the different pump displacement, motor power or system pressure.

RV POWER UNITS 1

General Description

- Bidirectional Gear Pump/DC Motor/Multi-functional Manifold/Valve/Tank
- Dual Pilot-operated Check Valve

Hydraulic Circuit Diagram

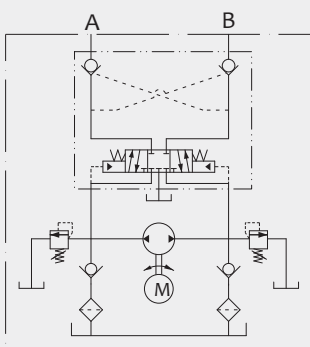

Special Notes

- This type of power unit works at S3 duty cycle, i.e., intermittent duty, 30 seconds on-load and 270 seconds off-load.
- Clean all the hydraulic parts concerned before mounting the power unit.
- Viscosity of the hydraulic oil should be 15~68 cst, which should also be clean and free of impurities. N46 hydraulic oil is recommended.
- Check the oil level in the tank after the initial operation of the power unit.
- Oil changing is required after the initial 100 operation hours, afterwards once every 3000 hours.

Outline Dimension

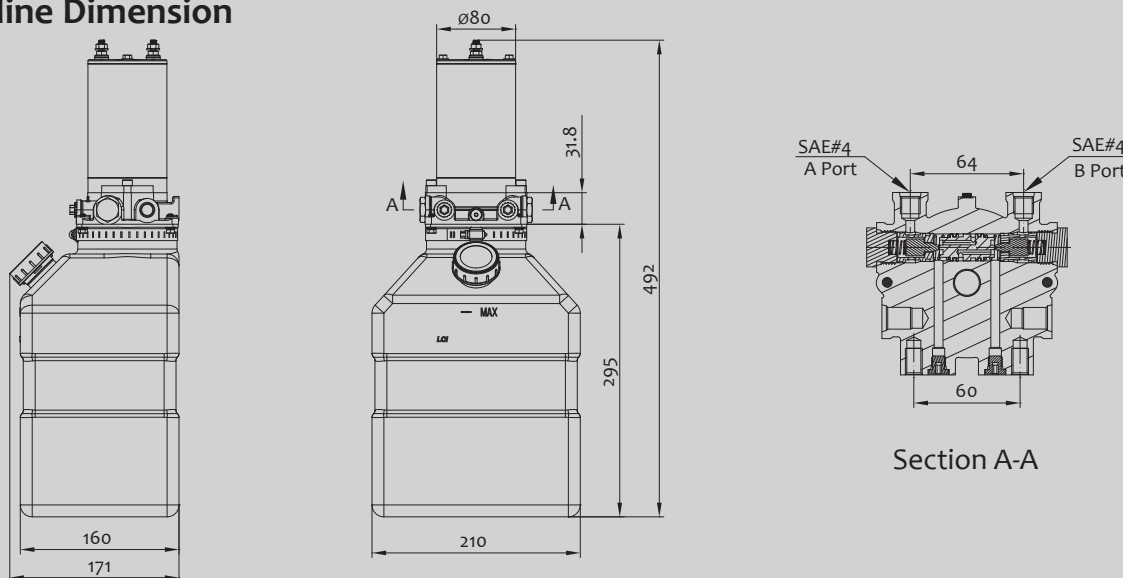

Model Specifications

Model	Motor Voltage	Motor Power	Rated Speed	Displacement	System Pressure	Tank Capacity
YBZS-Fo.88S1T108/UUYOT1	12VDC	0.8KW	3500RPM	0.88ml/r	20MPa	7L
YBZS-Fo.32V2T108/UUYOT1	24VDC			0.32ml/r		0.8L

Remark: Please go to page 1 or consult our sales engineer for the different pump displacement, motor power or system pressure.

RV POWER UNITS 2

General Description

- Bidirectional Gear Pump/DC Motor/Multi-functional Manifold/Valve/Tank
- Dual Pilot-operated Check Valve

Hydraulic Circuit Diagram

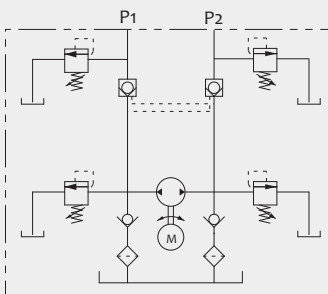

Special Notes

- This type of power unit works at S3 duty cycle, i.e., intermittent duty, 30 seconds on-load and 270 seconds off-load.
- Clean all the hydraulic parts concerned before mounting the power unit.
- Viscosity of the hydraulic oil should be 15–68 cst, which should also be clean and free of impurities. N46 hydraulic oil is recommended.
- Check the oil level in the tank after the initial operation of the power unit.
- Oil changing is required after the initial 100 operation hours, afterwards once every 3000 hours.

Outline Dimension

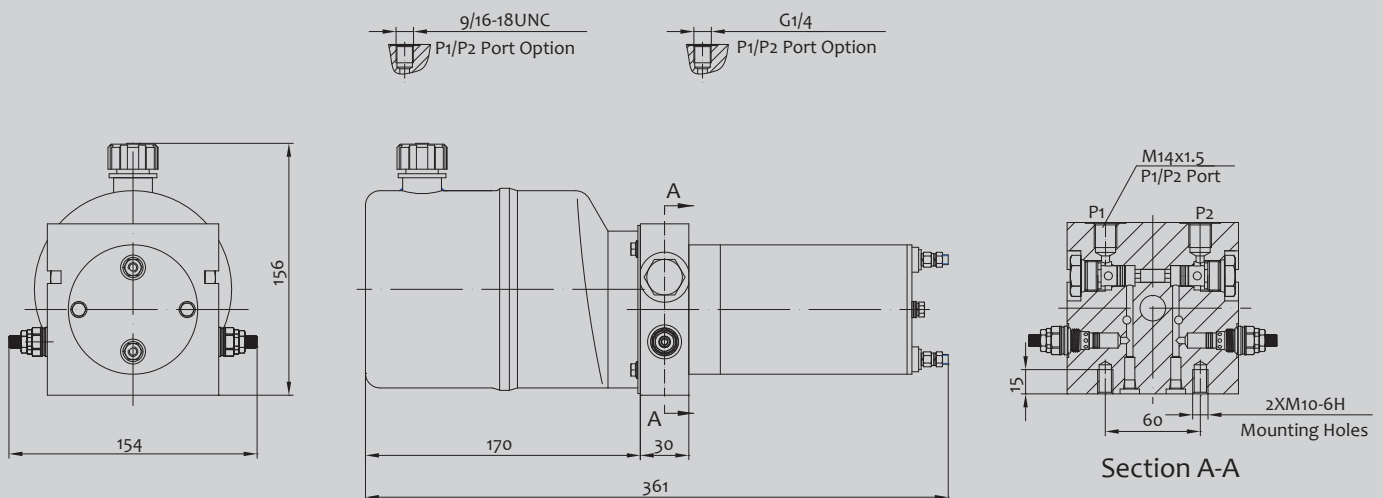

Model Specifications

Model	Motor Voltage	Motor Power	Rated Speed	Displacement	System Pressure	Tank Capacity
YBZS—Eo.5S1T101/1	12VDC	0.8KW	3500RPM	0.5ml/r	17.5MPa	1.4L
YBZS—Eo.63S2T101/1	24VDC			0.63ml/r		

Remark: Please go to page 1 or consult our sales engineer for the different pump displacement, motor power or system pressure.

POWER UNITS FOR MEDICAL CARE EQUIPMENT

General Description

- High Pressure Gear Pump/DC Motor/Multi-functional Manifold/Valve/Tank

Hydraulic Circuit Diagram

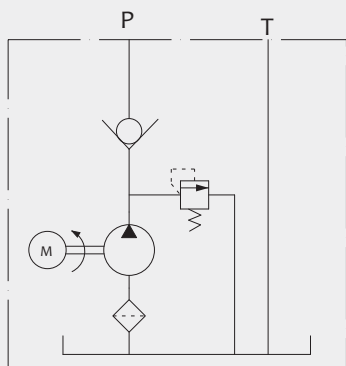

Special Notes

- This type of power unit works at S3 duty cycle, i.e., intermittent duty, 30 seconds on-load and 270 seconds off-load.
- Clean all the hydraulic parts concerned before mounting the power unit.
- Viscosity of the hydraulic oil should be 15~68 cst, which should also be clean and free of impurities. N46 hydraulic oil is recommended.
- Check the oil level in the tank after the initial operation of the power unit.
- Oil changing is required after the initial 100 operation hours, afterwards once every 3000 hours.

Outline Dimension

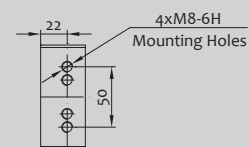
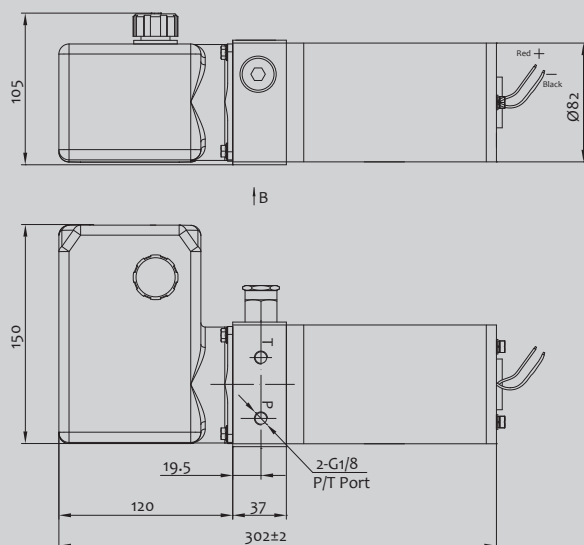

View B

Model Specifications

Model	Motor Voltage	Motor Power	Rated Speed	Displacement	System Pressure	Tank Capacity
YBZ5-Bo.32W2X0/UUTOTL1	24VDC	0.25KW	2500RPM	0.32ml/r	6.5MPa	1L
YBZ5-Co.26W2X0/UUTOTL1				0.26ml/r	10MPa	

Remark: Please go to page 1 or consult our sales engineer for the different pump displacement, motor power or system pressure.

POWER UNITS FOR ROAD PILE

General Description

- Bidirectional Gear Pump/AC Motor/Multi-functional Manifold/Valve/Tank
- Dual Pilot-operated Check Valve

Hydraulic Circuit Diagram

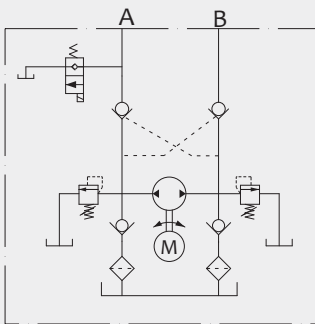

Special Notes

- This type of power unit works at S3 duty cycle, i.e., intermittent duty, 1 minute on-load and 9 minutes off-load.
- Clean all the hydraulic parts concerned before mounting the power unit.
- Viscosity of the hydraulic oil should be 15~68 cst, which should also be clean and free of impurities. N46 hydraulic oil is recommended.
- Check the oil level in the tank after the initial operation of the power unit.
- Oil changing is required after the initial 100 operation hours, afterwards once every 3000 hours.

Outline Dimension

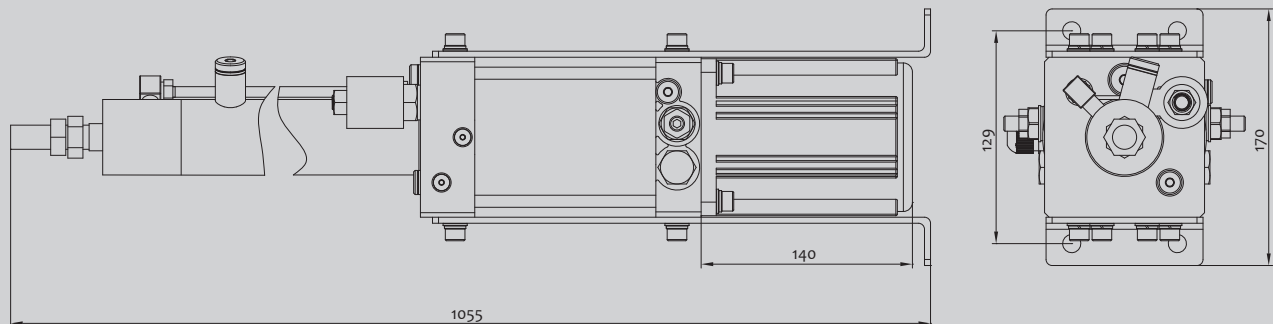

Model Specifications

Model	Motor Voltage	Motor Power	Rated Speed	Displacement	System Pressure	Tank Capacity	Solenoid Valve Voltage
YBZS-B1.5U3C108A/TCTBT1	220VAC	0.37KW	2850RPM	1.5ml/r	2.5MPa	0.5L	24VDC

Remark: Please go to page 1 or consult our sales engineer for the different pump displacement, motor power or system pressure.

POWER UNITS FOR TAIGATEK OF GARBAGE TRUCK

General Description

- High Pressure and Low Noise Gear Pump/DC Motor/- Multi-functional Manifold/Valve/Tank
- Two-way Shut-off Valve
- The Lowering Speed is Adjusted by the Flow Control Valve

Hydraulic Circuit Diagram

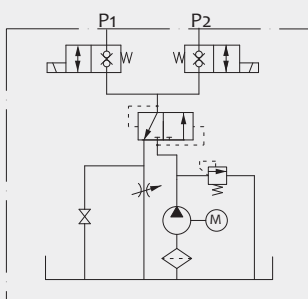

Special Notes

- This type of power unit works at S3 duty cycle, i.e., intermittent duty, 30 seconds on-load and 270 seconds off-load.
- Clean all the hydraulic parts concerned before mounting the power unit.
- Viscosity of the hydraulic oil should be 15–68 cst, which should also be clean and free of impurities. N46 hydraulic oil is recommended.
- Check the oil level in the tank after the initial operation of the power unit.
- Oil changing is required after the initial 100 operation hours, afterwards once every 3000 hours.

Outline Dimension

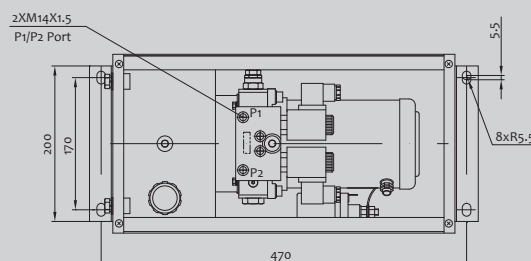
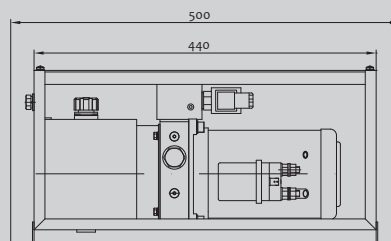
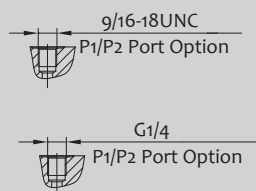
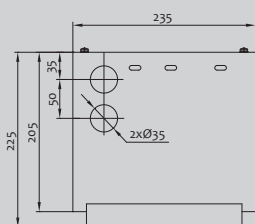

Model Specifications

Model	Motor Voltage	Motor Power	Rated Speed	Displacement	System Pressure	Tank Capacity	Solenoid Valve Voltage
YBZ5-D1.6A9A30/WUCTT2	48VDC	2KW	2500RPM	1.6ml/r	10MPa	3L	48VDC
YBZ5-D1.6A9A30/WUCAT1							12VDC

Remark: Please go to page 1 or consult our sales engineer for the different pump displacement, motor power or system pressure.

POWER UNITS FOR VEHICLE TAILGATE

General Description

- High Pressure and Low Noise Gear Pump/DC Motor/- Multi-functional Manifold/Valve/Tank
- The 3-way,2-Position Solenoid Valve
- The Lowering Speed of Ramp is Adjusted by an One-way Flow Control Valve

Hydraulic Circuit Diagram

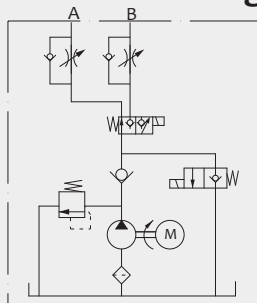

Special Notes

- This type of power unit works at S3 duty cycle, i.e.,intermittent duty,30 seconds on-load and 270 seconds off-load.
- Clean all the hydraulic parts concerned before mounting the power unit.
- Viscosity of the hydraulic oil should be 15~68 cst,which should also be clean and free of impurities.N46 hydraulic oil is recommended.
- Check the oil level in the tank after the initial operation of the power unit.
- Oil changing is required after the initial 100 operation hours,afterwards once every 3000 hours.

Outline Dimension

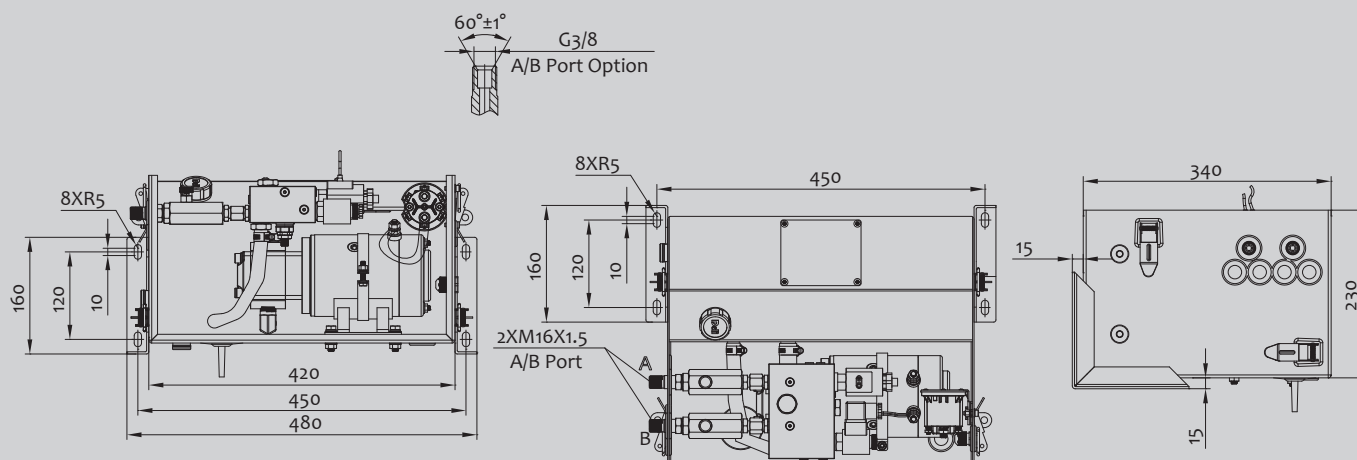

Model Specifications

Model	Motor Voltage	Motor Power	Rated Speed	Displacement	System Pressure	Tank Capacity	Solenoid Valve Voltage
YBZ5-E2.5E2A70C/WUCBO1	24VDC	2KW	2500RPM	2.5mL/r	16MPa	12L	24VDC
YBZ5-D3.2E2A70C/WUCBO1				3.2mL/r	12MPa		

Remark: Please go to page 1 or consult our sales engineer for the different pump displacement, motor power or system pressure.

DC MOTOR PUMP GROUP 1

Order Code

DMP-1S □ □ □ - □ □ X U A

DMP	DC motor pump group
1S	CB1S Pump Type
F	20MPa
E	16MPa
D	10MPa
C	6.5MPa
Operating Pressure	
9	9ml/r
6	6ml/r
4	4ml/r
3.2	3.2ml/r
Pump Displacement	
Design NO. A-Z	
U	2500RPM
Nominal Speed	
X	5"
Motor Type	
B	3KW
W	1.5KW
Motor Power	
2	24V
1	12V
Motor Voltage	
Omit or S SAE Ports	
G	Gas Threaded Ports
B	Metric Threaded Ports
Port Configurations	

Hydraulic Circuit Diagram

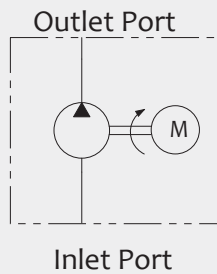

Special Notes

- This type of power unit works at S3 duty cycle, i.e., intermittent duty, 30 seconds on-load and 270 seconds off-load.
- Clean all the hydraulic parts concerned before mounting the power unit.
- Viscosity of the hydraulic oil should be 15~68 cst, which should also be clean and free of impurities. N46 hydraulic oil is recommended.
- Check the oil level in the tank after the initial operation of the power unit.
- Oil changing is required after the initial 100 operation hours, afterwards once every 3000 hours.

Outline Dimension

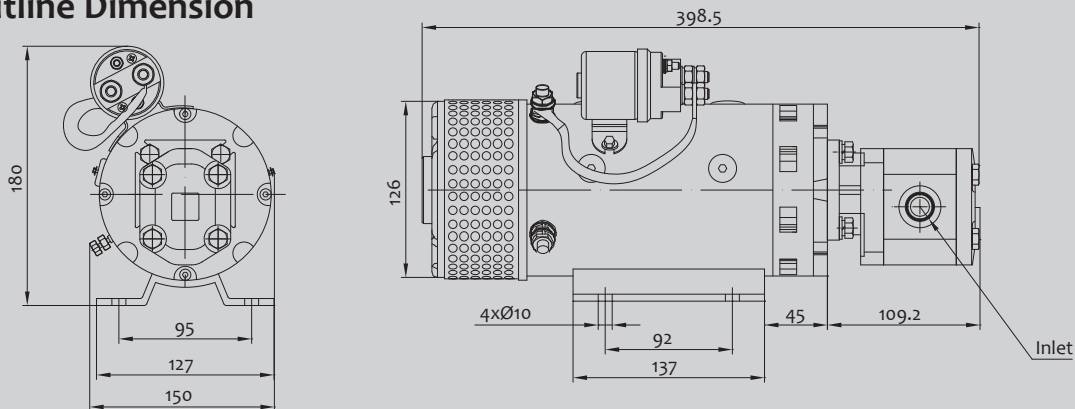

Model Specifications

Model	Motor Voltage	Motor Power	Displacement	System Pressure	Rated Speed
DMP-1SF3.2-2BXU-A	24VDC	3KW	3.2mL/r	20MPa	2500rpm
DMP-1SF4-2BXU-A			4mL/r	18MPa	
DMP-1SD6-2BXU-A			6mL/r	10MPa	
DMP-1SC9-2BXU-A			9mL/r	6.5MPa	

Remark: Please go to page 1 or consult our sales engineer for the different pump displacement, motor power or system pressure.

DC MOTOR PUMP GROUP 2

Order Code

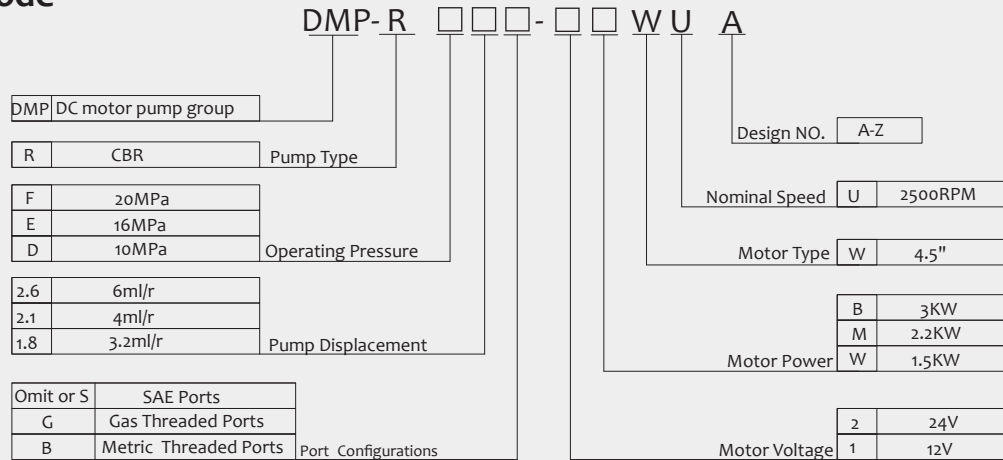

Hydraulic Circuit Diagram

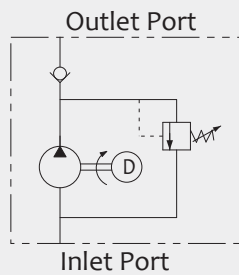

Special Notes

- This type of power unit works at S3 duty cycle, i.e., intermittent duty, 1 minute on-load and 9 minutes off-load.
- Clean all the hydraulic parts concerned before mounting the power unit.
- Viscosity of the hydraulic oil should be 15~68 cst, which should also be clean and free of impurities. N46 hydraulic oil is recommended.
- Check the oil level in the tank after the initial operation of the power unit.
- Oil changing is required after the initial 100 operation hours, afterwards once every 3000 hours.

Outline Dimension

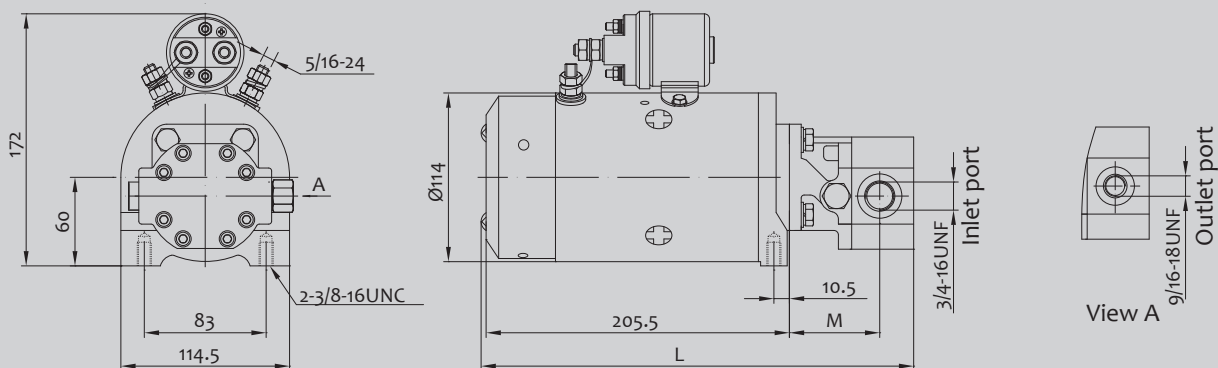

Model Specifications

Model	Motor Voltage	Motor Power	Rated Speed	Displacement	System Pressure	Dimension(mm)	
						M	L
DMP-RE1.8-1WWU-A	12VDC	1.5KW	2500RPM	1.8ml/r	16MPa	63.5	300.3
DMP-RE2.1-2MWU-A	24VDC	2.2KW		2.1ml/r			
DMP-RD2.6-2MWU-A				2.6ml/r	10MPa	71.8	301.3
DMP-RE2.1-9MWU-A	48VDC			2.1ml/r	16MPa	63.5	300.3

Remark: Please go to page 1 or consult our sales engineer for the different pump displacement, motor power or system pressure.

DC MOTOR PUMP GROUP 3

Order Code

DMP-CN □□ / □□ - □□ T T A

DMP	DC motor pump group	
CN	CBCN	Pump Type
F	20MPa	Operating Pressure
E	16MPa	
D	10MPa	
4	4.47ml/r	Front Pump Displacement
6	6.37ml/r	
4	4.47ml/r	Rear Pump Displacement
6	6.37ml/r	
Omit or S	SAE Ports	Port Configurations
G	Gas Threaded Ports	
B	Metric Threaded Ports	

Design NO.	A-Z
Nominal Speed	U 2500-3000RPM
Motor Type	T >5"
Motor Power	P 4.5KW
	I 3.3KW
Motor Voltage	9 48V
	2 24V
	1 12V

Hydraulic Circuit Diagram

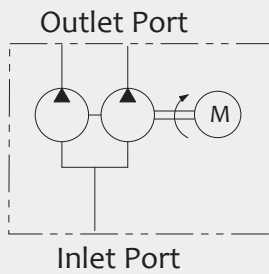

Special Notes

- This type of power unit works at S3 duty cycle, i.e., intermittent duty, 1 minute on-load and 9 minutes off-load.
- Clean all the hydraulic parts concerned before mounting the power unit.
- Viscosity of the hydraulic oil should be 15~68 cst, which should also be clean and free of impurities. N46 hydraulic oil is recommended.
- Check the oil level in the tank after the initial operation of the power unit.
- Oil changing is required after the initial 100 operation hours, afterwards once every 3000 hours.

Outline Dimension

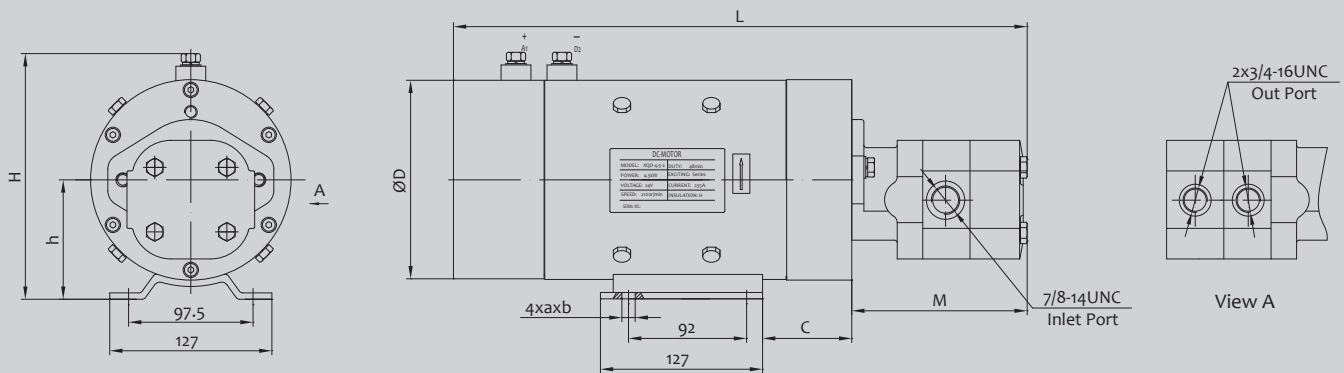

Model Specifications

Model	Motor Voltage	Motor Power	Rated Speed	Displacement (ml/r)		Operating Pressure	Dimension(mm)						
				Front	Rear		a×b	h	H	C	M	D	L
DMP-CNF6/4-2PTT-A	24VDC	4.5KW	2850RPM	6.47	4.47	20MPa	12×18.5	89	193	70	137.5	159	450.5
DMP-CNE6/4-9PTT-A	48VDC					16MPa							
DMP-CND4/4-2ITT-A	24VDC	3.3KW	2100RPM	4.47	4.47	10MPa	10.5×16.5	82	160	64	134.3	141.8	417.9

Remark: Please go to page 1 or consult our sales engineer for the different pump displacement, motor power or system pressure.

Bucher Hydraulics (Wuxi) CO.,Ltd.

add: No.225 Xitai Road,New District,Wuxi P.R.C

ZIP: 214112

Tel: +86-510-88550118

Sales: +86-510-88551778 88551806

<http://bh-wx.cn/>

info.wuxi@bucherhydraulics.com
