

# 汽车举升动力单元 2

## AUTO HOIST POWER UNITS 2

### 简介 General Description

本产品专为汽车举升机设计，动力上升，重力下降，适合不同的电压和频率，下降动作为手动控制，同时还可以用作液压叉车及剪叉式升降机的动力源。

This power unit is designed exclusively for Auto hoist, with power up, gravity down function. Such products can be applied to different voltages and frequencies and the lowering movement is controlled by the manual release valve. The power unit also applies to different kinds of hydraulic fork lift and scissors lift.



### 外形尺寸图 Outline Dimension

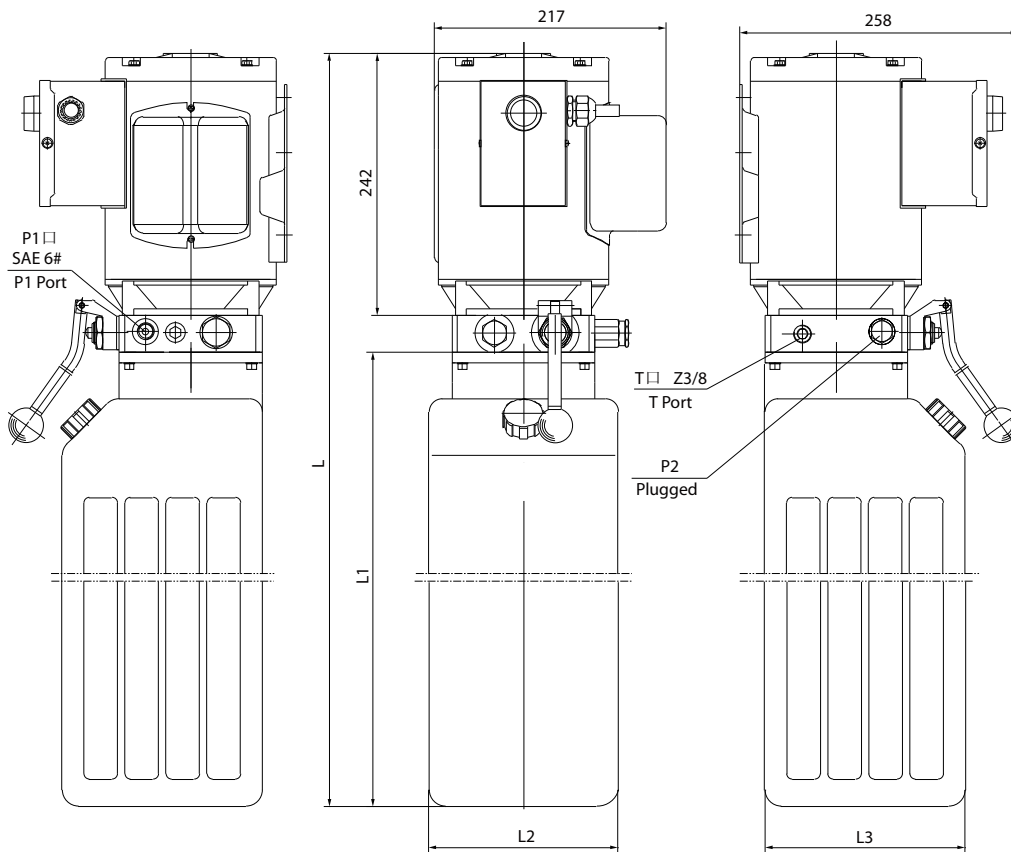

### 系统工作原理

#### Hydraulic Circuit Diagram

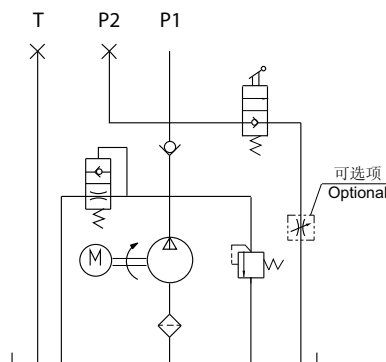

OIL SOLUTIONS

PO Box 38  
Strathfieldsaye, VIC, 3551  
1800 OIL SOL  
1800 645 765

[sales@oilsolutions.com.au](mailto:sales@oilsolutions.com.au)

[www.oilsolutions.com.au](http://www.oilsolutions.com.au)

"For All Your Hydraulic Needs"

## 型号规格说明 Model Specifications

Model 型号	Motor Volt 电机电压	Motor power 电机功率	Displacement 油泵排量	System pressure 溢流阀压力	Rated Speed 名义转速	Tank Capacity 油箱容量	Dimensions 尺寸					
							L1	L2	L3	L		
YBZ5-F0.8B5F1/ALVOT1	115V 60Hz	1.1KW	0.8ml/r	20MPa	3450rpm	6L	335mm	180mm	180mm	611mm		
YBZ5-F0.8C5F1/ALVOT1						8L	440mm			716mm		
YBZ5-E1.2B5F1/ALVOT1			6L	335mm		611mm						
YBZ5-E1.2C5F1/ALVOT1			8L	440mm		716mm						
YBZ5-F0.8B8F1/AMVOT1	115/230V 50/60Hz	1.1KW	0.8ml/r	20MPa	2830/3450rpm	6L	335mm	180mm	180mm	611mm		
YBZ5-F0.8C8F1/AMVOT1						8L	440mm			716mm		
YBZ5-E1.2B8F1/AMVOT2			6L	335mm		611mm						
YBZ5-E1.2C8F1/AMVOT1			8L	440mm		716mm						
YBZ5-F2.1E3H1/AMQOT1	208-240V 50/60Hz	2.2KW	2.1ml/r	20MPa	2830/3450rpm	12L	540mm	165mm	185mm	816mm		
YBZ5-F2.1F3H1/AMQOT1	14L					600mm	175mm	185mm	876mm			
YBZ5-F2.1E7H1/ALQOT1	230/460V 60Hz				3450rpm	12L	540mm	165mm	185mm	816mm		
YBZ5-F2.1F7H1/ALQOT1						14L	600mm	175mm	185mm	876mm		
YBZ5-F2.1E20H1/AMQOT1	190/208- 240/380/ 460V 50/60Hz		2.2KW	2.5ml/r	17.5MPa	2830/3450rpm	12L	540mm	165mm	185mm	816mm	
YBZ5-F2.5F20H1/AMQOT1							14L	600mm	175mm	185mm	876mm	
YBZ5-E4.2E20H1/ANQOT1				4.2ml/r		17.5MPa	1450/1725rpm	12L	540mm	165mm	185mm	816mm
YBZ5-E4.2F20H1/ANQOT1								14L	600mm	175mm	185mm	876mm

## 注意事项 Special Notes

1. 此交流电机不可连续运转 (1 分钟 ON, 9 分钟 OFF), 可重复工作。
2. 安装前必须保证油缸、油管、接头等液压元件清洁无任何杂质黏附。
3. 液压油粘度应为 15 ~ 68 CST, 应清洁无杂质, 推荐使用 N46 号液压油。
4. 本液压系统适用于垂直安装, 油箱在下。
5. 首次启动运行系统时, 应立即检查油箱中的油量是否充足。
6. 系统使用第一个 100 小时后, 应更换液压油, 以后每 3000 小时更换液压油一次。
7. 如需不同的流量、压力、电机功率等系统参数, 请在订货时说明。

1. The AC motor is of S3 duty cycle, which can only work intermittently and repeatedly, ie., 1minute on and 9 minutes off.
2. Clean all the hydraulic parts concerned before mounting the power unit.
3. Viscosity of the oil should be 15~68 cst, and the oil should be clean and free of impurities, N46 hydraulic oil is recommended.
4. The power unit should be mounted vertically.
5. Check the oil level in the tank after the initial running of the power unit.
6. Oil changing is required after the initial 100 operation hours, afterwards once every 3000 hours.
7. we are at your disposal to offer you the power units with your favorite power, flow, pressure as well as the tank capacity.