

双作用动力单元 1

DOUBLE ACTING POWER UNITS 1

简介 General Description

此动力单元由高压齿轮泵、直流电机、多用集成块、各式液压阀、油箱等零部件有机结合为一体。性能稳定，结构紧凑，广泛应用于汽车，园林机械，机床，物流设备等。

This power unit consists of high pressure gear pump, DC motor, multi-functional manifold, valves, tank, ect. It features stable performance and compact structure, and can be widely used in automotive, garden machineries, machine tools, logistics equipments etc.

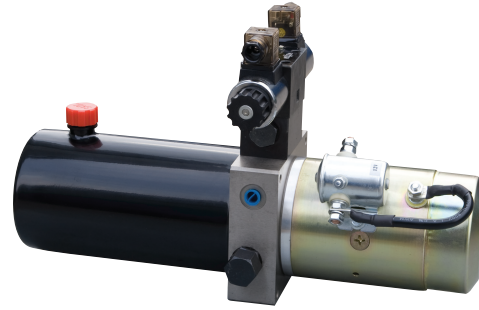

外形尺寸图 Outline Dimension

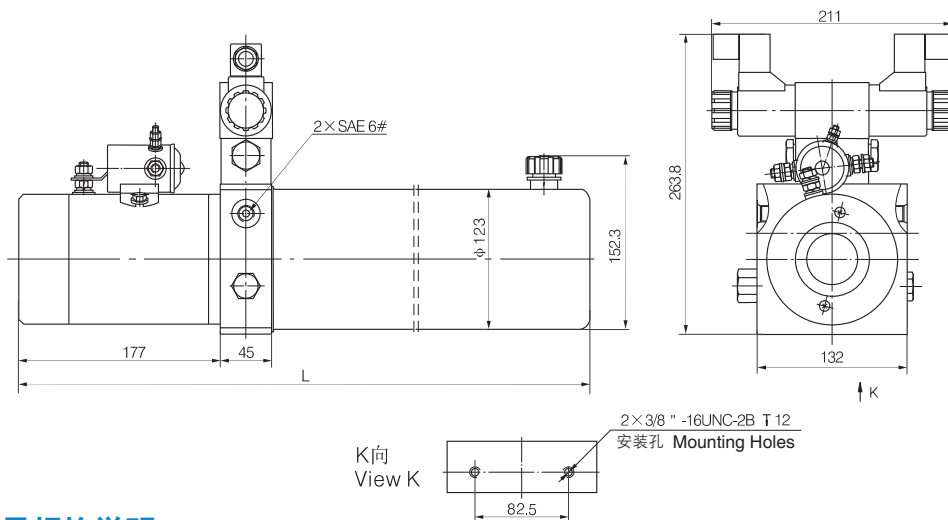

系统工作原理

Hydraulic Circuit Diagram

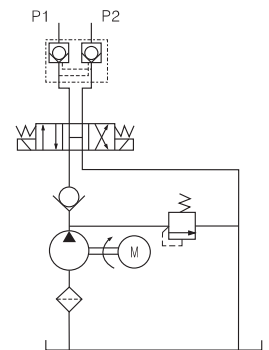

型号规格说明 Model Specifications

Model 型号	Motor Volt 电机电压	Motor power 电机功率	Rated Speed 名义转速	Displacement 油泵排量	System pressure 溢流阀压力	Tank Capacity 油箱容量	L(mm)
YBZ-F2.1A1W209/S	12VDC	1.5KW	2500rpm	2.1mL/r	20MPa	3L	567
YBZ-F2.5B2A209/S	24VDC	2KW		2.5mL/r	20MPa	5L	472
YBZ-F2.7B3G209/LBAEC1	220VAC	1.5KW	1400rpm	2.7mL/r	22MPa	6L	642
YBZ-F3.2E3G209/LBCEC1				3.2mL/r	20MPa	12L	692
YBZ-F2.5F3H209/LCCEC1		2.2KW	2800rpm	2.5mL/r	18MPa	14L	665
YBZ-E3.2G3H209/LCCEC1				3.2mL/r	15MPa	16L	597
YBZ-D4.2G3H209/LCCEC1	4.2mL/r			10MPa	16L	597	
YBZ-F2.7H4I209/LCCEC1	380VAC	3KW	2800rpm	2.7mL/r	20MPa	20L	930
YBZ-F3.2I4I209/LCCEC1				3.2mL/r	18MPa	22L	1015
YBZ-E3.7J4I209/LCCEC1				3.7mL/r	16MPa	25L	1100

说明：如需不同流量的泵、压力、电机功率等系统参数，请查看液压动力单元型号说明。

Remark: Please go to page 38 or consult our sales engineer for the different pump displacement, motor power or tank capacity.

注意事项 Special Notes

1. 此动力单元为 S3 工作制，不可连续运转，30 秒开、270 秒停。
2. 按装前必须保证油缸、油管、接头等液压元件清洁无任何杂质粘附。
3. 液压油粘度应为 15 ~ 68CST，应清洁无杂质，推荐使用 N46 号液压油。
4. 系统使用第一个 100 小时后，应更换液压油，以后每 3000 小时更换一次液压油。
5. 本液压动力单元适用于水平安装。

1. The duty of this power unit is S3, i.e., 30 seconds on and 270 seconds off.
2. Clean all the hydraulic parts concerned before mounting the power unit.
3. Viscosity of the hydraulic oil should be 15~68 cst, which should also be clean and free of impurities. N46 hydraulic oil is recommended.
4. Change the oil after the first 100 hours of running the power unit, then change the oil every 3000 hours.
5. The power unit should be mounted horizontally.