

电动环卫车动力单元

POWER UNITS FOR TAILGATE OF GARBAGE TRUCK



简介 General Description

此动力单元有两条独立的油路，分别用于控制轻型垃圾车尾板装置的提升缸和翻转缸，油缸的下降速度由压力补偿流量阀自动调节。本动力单元还可用于其他各种需要两条独立液压油源的情况，比如：双托盘车、子母剪升降台等。

Equipped with two zero leakage double-check solenoid valves, this power unit has two independent circuits for the lifting cylinder and rotating cylinder of tailgate of electrical garbage truck. The lowering speed of the cylinders is regulated by the pressure compensated flow valve in the return line. This power unit can also be used in those applications where two separated hydraulic circuits are needed such as double scissors lift, double-pallet mover etc.



外形尺寸图 Outline Dimension

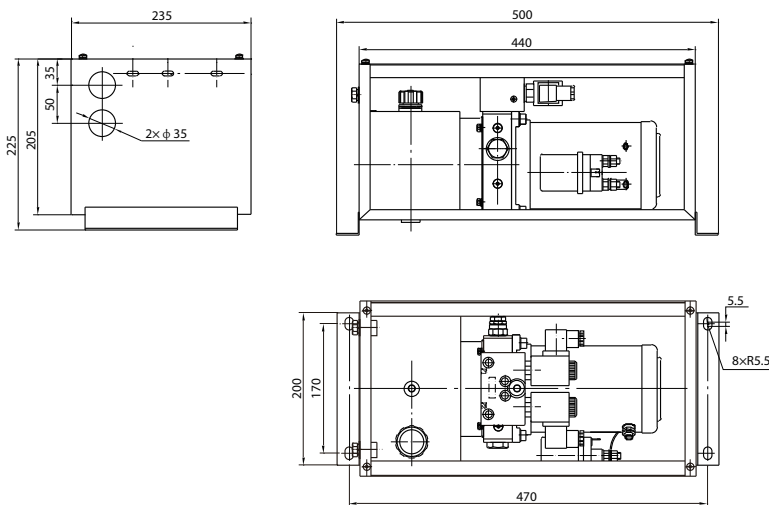

系统工作原理 Hydraulic Circuit Diagram

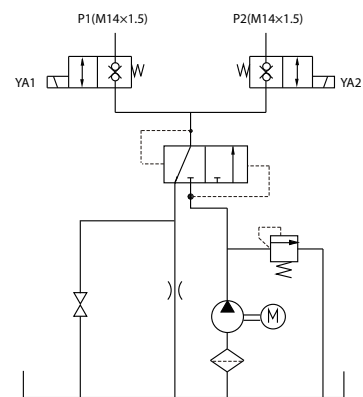

型号规格说明 Model Specifications

Model 型号	Motor Volt 电机电压	Motor Power 电机功率	Rated Speed 名义转速	Displacement 油泵排量	System Pressure 溢流阀压力	Tank Capacity 油箱容量
YBZ5-D1.6A9A30/WUCTT2	48VDC	2KW	2500rpm	1.6mL/r	12MPa	3L

说明：1. 如需不同流量的泵、压力、电机功率等系统参数，请查看液压动力单元型号说明

Remark: 1. Please go to page 38 or consult our sales engineer for the different pump displacement, motor power or tank capacity.

注意事项 Special Notes

1. 此动力单元为 S3 工作制，不可连续运转，30 秒开、270 秒停。
2. 安装前必须保证油缸、油管、接头等液压元件清洁无任何杂质粘附。
3. 液压油粘度应为 15 ~ 68CST，应清洁无杂质，推荐使用 N46 号液压油。
4. 本液压动力单元适用于立式安装。
5. 首次启动运行系统后，应立即检查油箱中的油量是否充足。
6. 系统使用第一个 100 小时后，应更换液压油，以后每 3000 小时更换一次液压油。

1. The duty of this power unit is S3, i.e., 30 seconds on and 270 seconds off.
2. Clean all the hydraulic parts concerned before mounting the power unit.
3. Viscosity of the oil should be 15~68 cst, and the oil should be clean and free of impurities, N46 hydraulic oil is recommended.
4. This power unit should be mounted vertically.
5. Check the oil level in the tank after the initial run of the power unit.
6. Oil changing is required after the initial 100 operation hours, afterwards once every 3000 hours.