

简介 General Description

此动力单元由双向齿轮泵、直流电机、多用集成块、各式液压阀、油箱等零部件有机结合为一体，尤其是该双向动力单元在没有换向阀的情况下，同样能顺利的完成换向的任务，这就使的该动力单元体积小、美观，同时该动力单元结构紧凑、性能稳定。广泛应用于叉车、机床等设备。

Equip with a reversible bidirectional gear pump, double P.O. check valves, relief valves and a tank etc. this power unit can drive a double acting cylinder to extend and retract without a directional solenoid valve. It is typically used in recreational vehicles and machine tools.



系统工作原理

Hydraulic Circuit Diagram



外形尺寸图 Outline Dimension

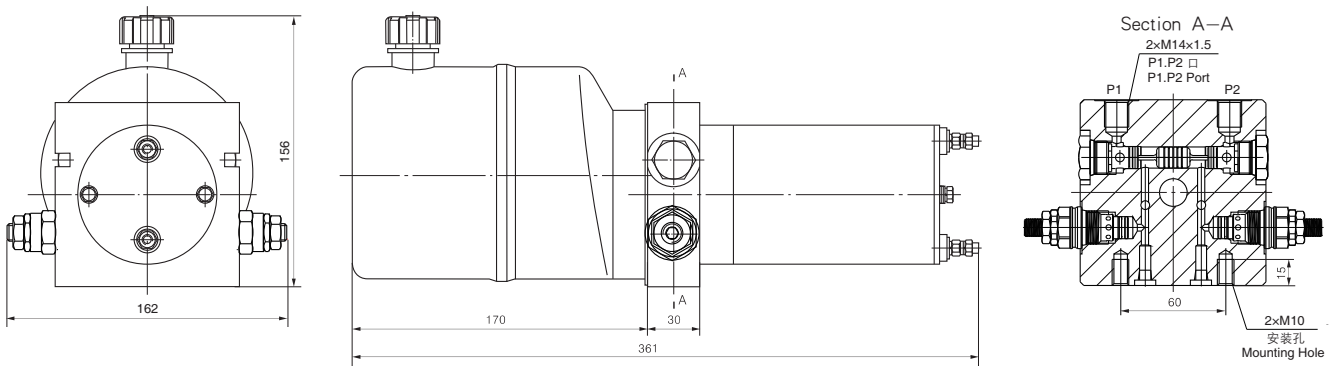

型号规格说明 Model Specifications

Model 型号	Motor Volt 电机电压	Motor power 电机功率	Displacement 油泵排量	System pressure 溢流阀压力	Tank Capacity 油箱容量
YBZS - E0.5S1T101/1	12VDC	0.8KW	0.5mL/r	17.5MPa	1.4L
YBZS - E0.63S2T101/1	24VDC		0.63mL/r		

说明：如需不同流量的泵、压力、电机功率等系统参数，请查看液动力单元型号说明。

Remark: Please go to page 38 or consult our sales engineer for the different pump displacement, motor power or tank capacity.

注意事项 Special Notes

1. 此动力单元为S3工作制，不可连续运转，30秒开、270秒停。
2. 按装前必须保证油缸、油管、接头等液压元件清洁无任何杂质粘附。
3. 液压油粘度应为15~68CST，应清洁无杂质，推荐使用N46号液压油。
4. 本液动力单元适用于水平或垂直安装。
5. 首次启动运行系统后，应立即检查油箱中的油量是否充足。
6. 系统使用第一个100小时后，应更换液压油，以后每3000小时更换一次液压油。

1. The duty of this power unit is S3, i.e., 30 seconds on and 270 seconds off.
2. Clean all the hydraulic parts concerned before mounting the power unit.
3. Viscosity of the hydraulic oil should be 15~68 cst, which should also be clean and free of impurities. N46 hydraulic oil is recommended.
4. The power unit can be mounted horizontally or vertically.
5. Check the oil level in the tank after the initial running of the power unit.
6. Oil changing is required after the initial 100 operation hours, afterwards once every 3000 hours.