

Welcome To **BUCHER**
hydraulics

POWER UNITS

Our quality: We always adhere to the implementation of ISO9001 quality management system and continuously strengthen and improve internal management, as well as providing our customers with best quality products. Quality and service is our sincere commitment.



Search:

Position: Index >> Products

Gear Pumps and Gear Motors **Power Units** **Hydraulic Valves** **Accessories**

RV Power Units

RV Power Units

[General Description](#)



Equipped with a reversible motor, a bidirectional gear pump, double P.O. check valves, relief valves and a tank etc. this power unit can drive a double acting cylinder to extend and retract without a directional solenoid valve. It is typically used in recreational vehicles and machine tools.

[Outline Dimension](#)

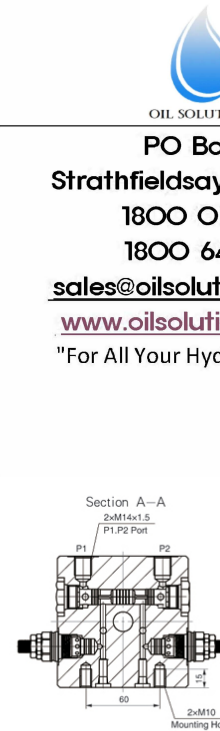
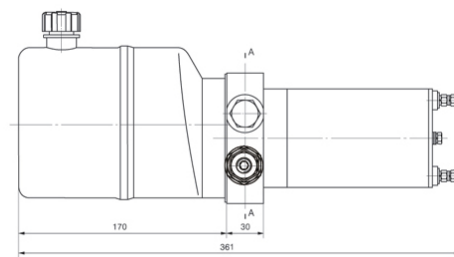
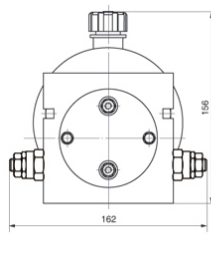
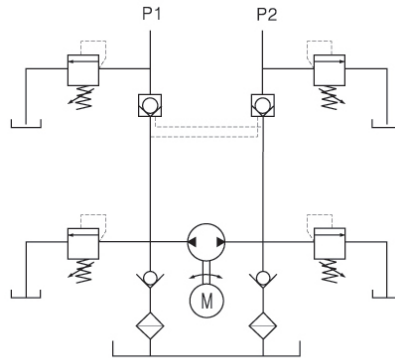

OIL SOLUTIONS

PO Box 38
Strathfieldsaye, VIC, 3551
1800 OIL SOL
1800 645 765
sales@oilsolutions.com.au
www.oilsolutions.com.au
"For All Your Hydraulic Needs"

[Model Specifications](#)

Model	Motor Volt	Motor power	Displacement	System pressure	Tank Capacity
YBZS - E0.5S1T101/1	12VDC	0.8KW	0.5mL/r	17.5MPa	1.4L
YBZS - E0.63S2T101/1	24VDC		0.63mL/r		

Remark: Please go to page 38 or consult our sales engineer for the different pump displacement, motor power or tank capacity.

Special Notes

- 1.The duty of this power unit is S3, i.e., 30 seconds on and 270 seconds off.
- 2.Clean all the hydraulic parts concerned before mounting the power unit.
- 3.Viscosity of the hydraulic oil should be 15-68 cst, which should also be clean and free of impurities. N46 hydraulic oil is recommended.
- 4.The power unit can be mounted horizontally or vertically.
- 5.Check the oil level in the tank after the initial running of the power unit.
- 6.Oil changing is required after the initial 100 operation hours, afterwards once every 3000 hours.

Copyright: Bucher Hydraulics (Wuxi)Co.,Ltd. 编号: 苏ICP备18069474号-1