

塑料管道熔焊设备动力单元 POWER UNIT FOR PLASTIC TUBE-WELDING MA-

德力液压 **Deli**®

简介 General Description

本动力单元专为塑料管道熔焊机设计，用电磁阀实现对熔焊机工作部件的移动控制，液压锁和蓄能器配合使用保证了系统的保压性能，本动力单元体积小、重量轻、美观、可靠，尤其适用于现场作业的熔焊设备。

Consisting of AC motor, gear pump, tank, valves, manifolds and accumulator, this power unit is designed for portable plastic tube melting machines. The movement of machine's carriage mechanism is controlled by the solenoid directional valve. The combination of PO check and accumulator ensures an extraordinary pressure holding performance of the system. This power unit is not only compact and light, but also elegant and reliable.



系统工作原理

Hydraulic Circuit Diagram

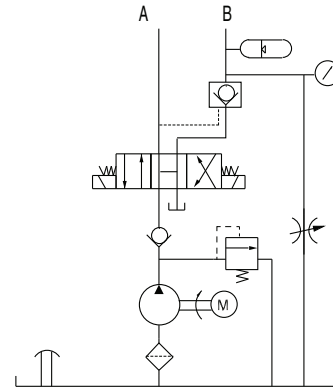

外形尺寸图 Outline Dimension

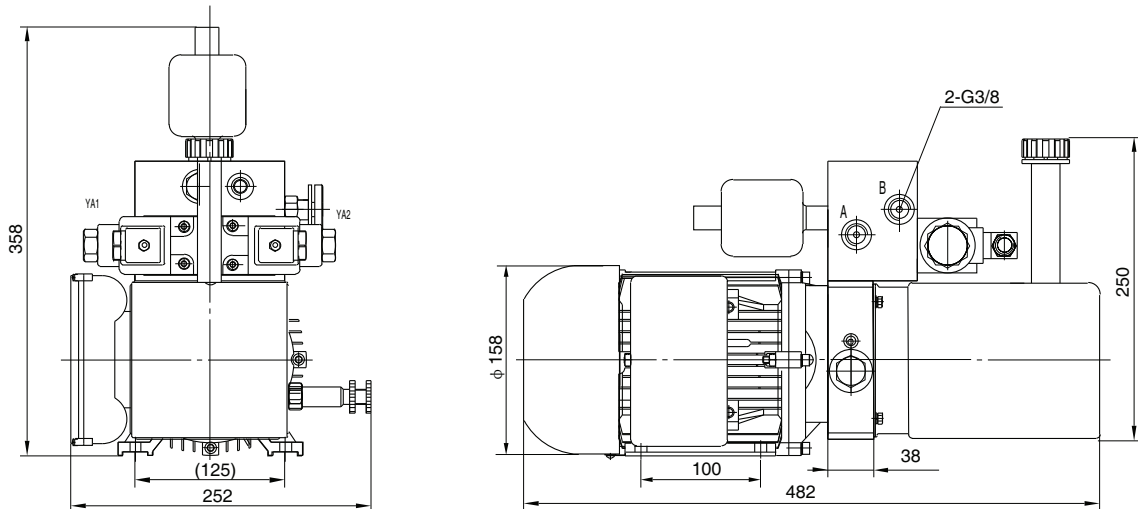

型号规格说明 Model Specifications

Model 型号	Motor Volt 电机电压	Motor Power 电机功率	Motor Speed 电机转速	Displacement 油泵排量	System Pressure 溢流阀压力	Tank Capacity 油箱容量
YBZ-D1.6A3F211/LCCET1	220VAC	1.1KW	1450RPM	1.6mL/r	10MPa	6L
YBZ-D1.6A4F211/LCCET1	380VAC					

说明: 如需不同流量的泵、压力、电机功率等系统参数，请查看液动力单元型号说明。

Remark: Please go to page 38 or consult our sales engineer for the different pump displacement, motor power or tank capacity.

注意事项 Special Notes

1. 此动力单元不可连续运转 (1 分钟 ON, 9 分钟 OFF), 可重复工作。
2. 按装前必须保证油缸、油管、接头等液压元件清洁无任何杂质粘附。
3. 液压油粘度应为 15 ~ 68CST, 应清洁无杂质, 推荐使用 N46 号液压油。
4. 首次启动运行系统后, 应立即检查油箱中的油量是否充足。
5. 系统使用第一个 100 小时后, 应更换液压油, 以后每 3000 小时更换一次液压油。

1. This power unit is of S3 duty, i.e., which can only work intermittently and repeatedly, 1 minute on and 9 minutes off.
2. Clean all the hydraulic parts concerned before mounting the power unit.
3. Viscosity of the hydraulic oil should be 15~68 cst, which should also be clean and free of impurities. N46 hydraulic oil is recommended.
4. Check the oil level in the tank after the initial operation of the power unit.
5. Oil changing is required after the initial 100 operation hours, afterwards once every 3000 hours.