



BREVINI[®]

Motion Systems



1800-OILSOL
1800-645765

<https://oilsolutions.com.au/>

sales@oilsolutions.com.au

OT 100 SERIES GEAR PUMPS AND MOTORS

Technical Catalogue





BREVINI

Motion Systems

OT OilTechnology is a young Company, founded in November 2001, which makes a comprehensive range of external gear pumps, motors and flow dividers.

From the technical side OT Oiltechnology has realized an "up-to date" project that is in line with the new needs of the market.

The OT Oiltechnology keys to succes are the following:

- SERVICE: A very good service, higly flexible, most important attribute of the Company.**
- QUALITY: Costant quality control and 100% product resting to achieve the best results possible from our working processes.**
- PRICE: Low overheads together with an efficient working process to offer competitive prices.**
- TO BE A PARTNER OF OUR CUSTOMERS: This is the MISSION of OT OilTechnology.**



THE COMPANY

Dana Brevini Fluid Power was established in 2003 in Reggio Emilia where it has its head office.

Dana Brevini Fluid Power manufactures hydraulic components and application packages: a very large range suited to several operational requirements and applications thanks to a strict interaction between mechanical, hydraulic and electronic components.

Brevini Fluid Power is among the top manufacturers in Italy and major player in Europe and in the world.

INTERNATIONAL PRESENCE

Dana Brevini Fluid Power operates internationally with 15 branches all over the world placed in major industrialized countries: Italy, France, Germany, England, Romania, Holland, China, India, Singapore and the United States. The network is constantly expanding by opening new branches in just a few years.

The branches are guided by managers that have an excellent knowledge of their own country.

The advantages this brings are evident:

- **Reduced delivery times thanks to the branches warehouses;**
- **Easy customization of products and systems basing on the customer's needs, thanks to the competence and professional skills of the branches' own technical and servicing departments;**
- **Quick servicing;**
- **A ready sales staff at hand and closer to the customers, which ensures high flexibility plus experience.**

The production facilities are located throughout Reggio Emilia, Ozzano Emilia (BO) , Fontevivo (PR), Novellara (RE), Yancheng (province of Jiangsu, China) which was inaugurated in 2009 and became operative since 2010.

COMPETITIVE STRATEGY

Innovation combined with the focus on customers is the strenght of the Brevini Fluid Power "brand" , born from the forty-year-long experinces of Aron, Hydr-App, SAM Hydraulik, VPS Brevini and Brevini Hydraulics. Brevini Fluid Power proposes itself as a "local hub" , as it happened to BPE Electronics in 2009 and OT Oiltechnology in 2010, in order to create a new Made in Italy global player in the world of hydraulics, increasingly more integrated with electronics.

The purpose is still the development of a very large range of products forming together integrated packages able to meet various application needs. Our ten-year-long partnership relations with hundreds of customers all over the world are the best synthesis of Brevini Fluid Power's operational philosophy.

Sharing of Know-how and several experiences have made Dana Brevini Fluid Power a more global company, more incisive in international markets and closer to its customers.

PRODUCT LINES

The product lines are numerous and well-structured aimed to cover every needs: a strong basis on which to develop the engineering of application packages and complete systems. The offer is improving in the direction of a solution supplier often developed in co-design with the customer, both for the mobile and industrial sector.

- **Hydraulic power packs and mini hydraulic packs (whether standard or customised), cartridge valves and solenoid valves, gear boxes and transmission components.**
- **Axial piston pumps and motors for medium and high pressure, orbital motors.**
- **Directional, flow, on-off and proportional pressure control valves. Modular and cartridge valves, subplates and blocks.**
- **Proportional directional valves, joysticks and electronics modules.**
- **Sensors, load cells, boards and electronic controls via CAN, display units, planarity indicators.**
- **Mono-block and modular mobile valves.**
- **Gear pumps and motors, flow dividers.**



GROUP 1 PUMPS

GENERAL INDEX

- Constructive and general characteristics, installation instructions	Pag. 4 - 5 - 6 - 7
- Changing rotation	Pag. 8
- Bearing calculation	Pag. 9
- Characteristics curves - pump calculation	Pag. 10 - 11
- European standard pumps	Pag. 12 - 13 - 14
- Pumps for power units	Pag. 15 - 16 - 17 - 18 - 19 20 - 21
- SAE " AA " standard pumps	Pag. 22 - 23 - 24
- Pumps with front bearing	Pag. 25 - 26 - 27
- Reversible pumps	Pag. 28 - 29
- Pumps with maximum relief valve	Pag. 30 - 31
- Tandem pumps	Pag. 32 - 33
- Tandem pumps with sequence valve HI-LOW	Pag. 34 - 35 - 36
- Unidirectional motors	Pag. 37
- Motors : characteristics curves	Pag. 38 - 39 - 40 - 41
- Reversible motors	Pag. 42 - 43
- Special versions	Pag. 44 - 45

GROUP 1 PUMPS TECHNICAL CATALOGUE

www.brevini.com

GROUP 1 PUMPS

GEAR HOUSING

Extruded in aluminium alloy

DRIVE SHAFTS

Choice of several standard drive shafts

BEARINGS

Hi-resistant aluminium alloy with DU sleeve bearings to offer high performances.

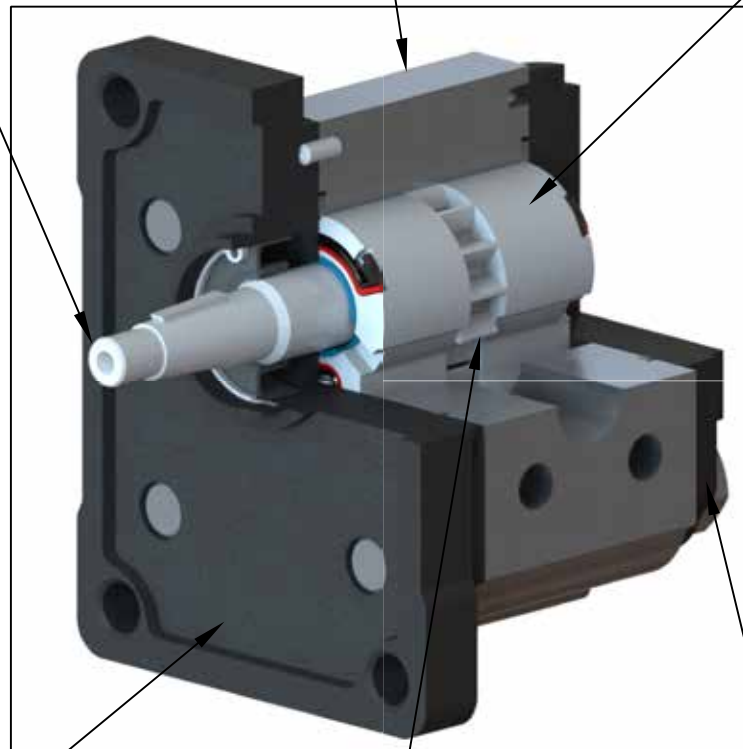
**MOUNTING FLANGES**

Choice of several mounting flanges in cast iron

COVER

Made in cast iron material and available with suction port

GEARS

Designed specifically to reduce the noise level and offer the best performance between flow pulsation and displacements

GROUP 1 PUMPS

CONSTRUCTIVE CHARACTERISTICS:

PART	MATERIAL	CHARACTERISTICS
GEARS	Hardened steel UNI 7846	Rs= 1250 N/mm² Rm= 1450 N/mm²
FLANGE AND COVER	G25 / G30 cast iron	Rs= 300 N/mm² Rm= 450 N/mm²
BEARINGS	Sical 3 Bearings with DU	Rs= 350 N/mm² Rm= 390 N/mm²
BODY	Etruded in aluminium alloy Series 7020	Rs= 350 N/mm² Rm= 390 N/mm²
O-RINGS	Buna N Viton	90 Shore, up to 90°C 80 Shore, for high temperature
ANTIEXTRUSION	Zitel	With glass fibres

Rs= Enervation load

Rm= Breaking load

GENERAL CHARACTERISTICS:

Maximum pressures up to 300 bar

Weight : from 0.9 Kg to 1.6 kg

Maximum speed up to 5.000 rpm

Type of shafts:

Taper 1:8

Oldham

Slined DIN 5482

SAE AA

Keyed

Type of flanges:

European standard

Standard for power units

SAE AA standard

Displacements from 0.73 cc/rev to 9.9 cc/rev

The displacements are available according this table:

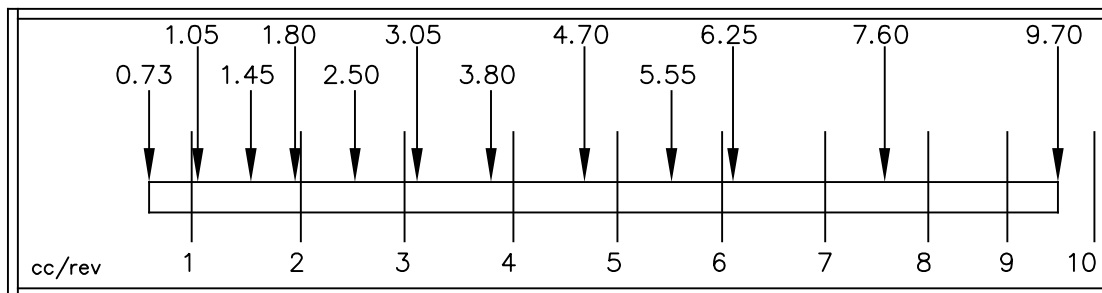

There is also available a special version with built-in support and a bigger taper 1:8 shaft (diameter Ø14) for 9.9 cc/rev pump.

In the range there are tandem pumps with unloading valve in the back cover and pumps with built in maximum pressure relief valve (with internal or external drain)

DRIVE:

The connection of the pump to the motor must be done preferably with the use of a flexible coupling to avoid any radial and/or axial force on the shaft, otherwise pump efficiency will dramatically drop due to early wear of inner moving parts.

In any applications where the motion is trasmitted through belts, it is necessary to use a support to avoid any radial or axial load to the pump shaft.

In any applications where are used splined shafts of Oldham couplings, it is suggested to assure a costant lubrication through grease or similar products.

GROUP 1 PUMPS

WORKING CONDITIONS- LIMIT PERFORMANCES

In normal working conditions there must be, in the suction pipe, a pressure lower than the atmospheric pressure.

The pressure range in suction must be:

Min. 0.75 bar (absolute)

Max 2,0 bar (absolute)

The maximum pressure values "P1" are referred to a continuous working at 1500 rpm with standard hydraulic fluids with minimum viscosity of 10 cSt.

For heavier working conditions (viscosity or high temperature) it is necessary to reduce the "P1" values.

In the following table are described the admitted pressures:

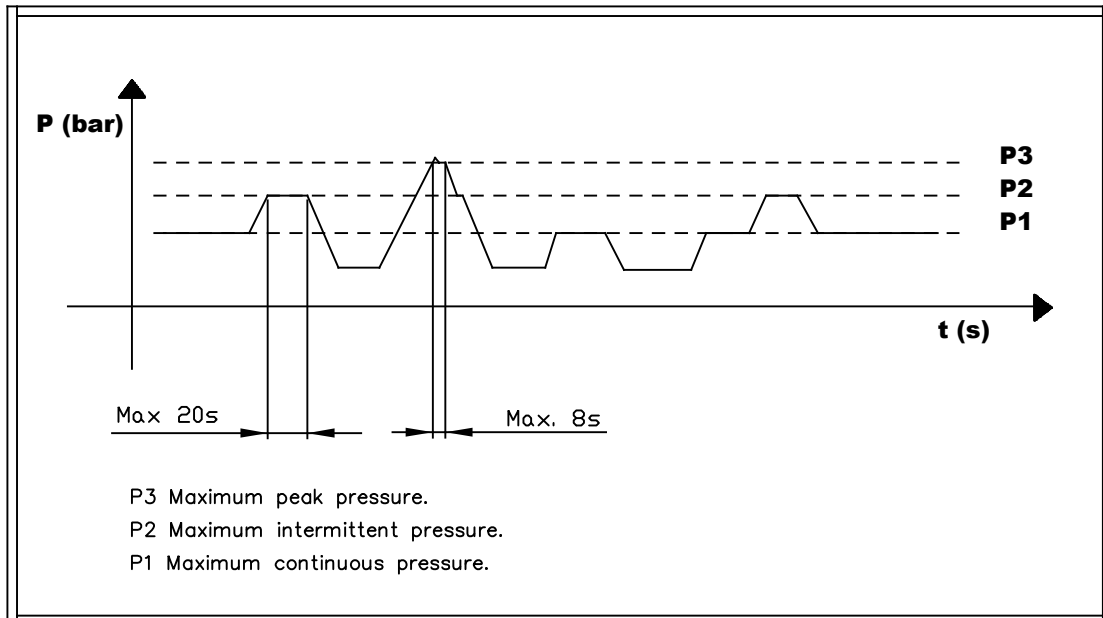

The standard working speeds (minimum and maximum) are the following:

Min. = 750 rpm

Max = (See following tables)

DIRECTION OF ROTATION LOOKING AT THE SHAFT:

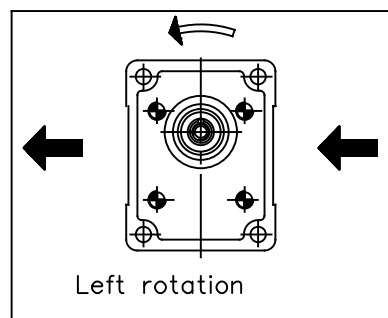
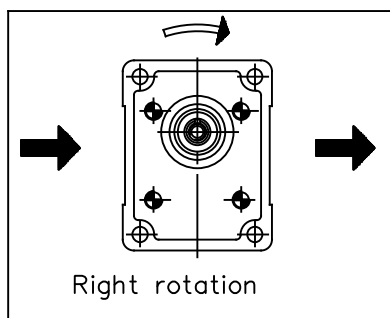



GROUP 1 PUMPS

FLUID FILTRATION

It is known that in many cases the premature pump performances reduction is due to a non correct filtration in the circuit.

The presence of contamination particles in the fluid usually corresponds to an irreparable wear of the pump internal parts.

It is recommended to pay attention to the plant cleaning, mainly in the starting activity.

The starting fluid contamination it must be according to the Norms ISO 4406 and it should not exceed the Class 19/16 with a filter 3x75.

Here below the technical parameters to respect:

FILTRATION IN SUCTION LINE	30 / 60 Nominal micron
FILTRATION IN PRESSURE LINE	10 / 25 absolute micron
MAXIMUM SPEED IN SUCTION	0.5 / 1.5 m/s
MAXIMUM SPEED IN OUTPUT	3.0 / 5.5 m/s

Sometime in contaminated places it is recommended to improve the filtration in pressure line and fit also an air filter.

HYDRAULIC FLUIDS

It is recommended the use of fluids made for hydraulic circuits.

Usually they are hydraulic oils with mineral basis HLP HV (DIN 51524).

Here below the technical parameters to respect:

MINIMUM VISCOSITY	10 mm²/s
MAXIMUM VISCOSITY ✱	750 mm²/s
SUGGESTED VISCOSITY	20 mm²/s / 100 mm /s
SUGGESTED TEMPERATURE	30°C / 50°C
WORKING TEMPERATURE	-15°C / +80°C

For applications with water-glycol (HF-C) it is recommended to consider the following limitations: 1500 rpm maximum speed and 200 bar maximum pressure.

For applications with phosphate ester fluids, please contact our Technical department.

✱ From 0.7 cc until 1.1 cc **MAXIMUM VISCOSITY 500 mm /s**

INSTALLATION INSTRUCTION

During the first starting it is recommended:

- to set the maximum pressure relief valves to a low value and gradually increase the pressure.
- to check, with single rotation pumps, that the rotation direction it is correct.
- to check that the connection between the motor and pump shaft is correct: without radial or axial load.
- to avoid starting under pressure in low temperature conditions or after long period of inactivity
- to check the fluid level in the tank
- to disconnect the return pipe and purge any air in the circuit
- to protect the pumpshaft seal when painting power pack
- to use suitable systems in the return lines to tank, to avoid turbulence in the circuit and ingress of air, water or contamination
- to check the torque that must be lower than the maximum torque admissible on the pump shaft
- to use new oil filters with absence of water or any other emulsifying substance
- to avoid starting with a air-oil solution

It is important to specify an oil tank at least twice the flow from the pump.

GROUP 1 PUMPS- CHANGING ROTATION

TO CHANGE ROTATION OF OT100 PUMP IT'S NECESSARY TO OPERATE IN THE FOLLOWING WAY:

1. Clean the pump externally with care.
2. Loosen, and remove, the clamp bolts (E).
3. Coat the sharp edges of the drive shaft (D) with adhesive tape and smear a layer of clean grease on the shaft end extension to avoid damaging the lip of the shaft seal when removing the mounting flange.
4. Remove the mounting flange (A), taking care to keep the flange as straight as possible during removal. Ensure that while removing the front mounting flange, the drive shaft and other components remain in position.
5. Ease the drive gear (D) up to facilitate removal of bearings (B), taking care that the precision ground surfaces do not become damaged, and removed the drive gear.
6. Remove the driven gear (D) without overturning. The rear flange has not to be removed.
7. Re-locate the driven gear (C) in the position previously occupied by the drive gear (D).
8. Re-locate the drive gear (D) in the position previously occupied by the driven gear (C).
9. Replace the front flange (A) in its original position.
10. Gently wipe the machined surface of the front flange (A) and the body with a canvas.
11. Refit the front mounting flange (A) turned by 180° from its original position.
12. Refit the clamp bolts (E). (**SCREW TIGHTENING TORQUE = 28 Nm**)
13. Check that the pump rotates freely when the drive shaft (D) is turned by hand. If not a pressure plate seal may be pinched.
14. The pump is ready for installation with the original rotation reversed.

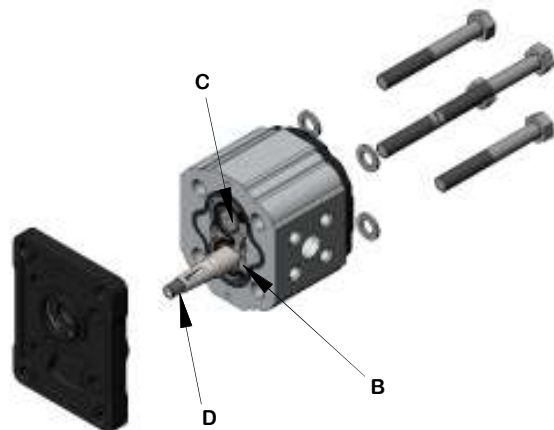
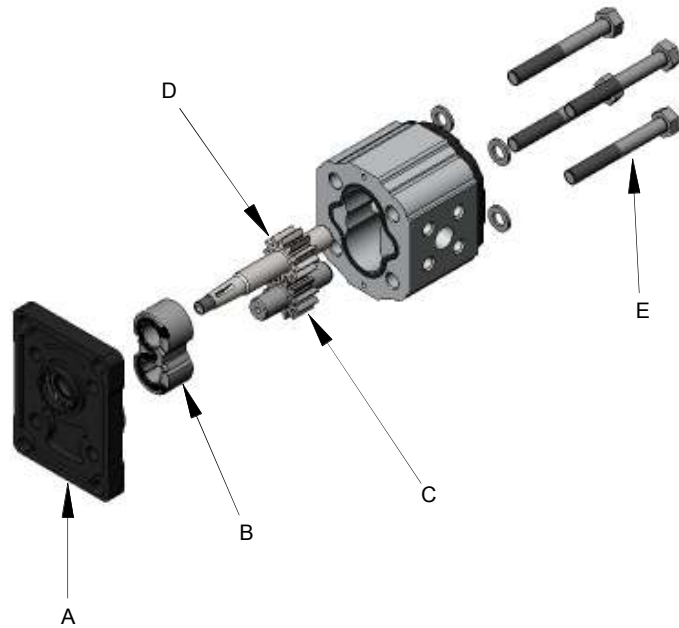

GROUP 1 PUMPS - WITH FRONT BEARING

VERIFY OF BEARING DURATION

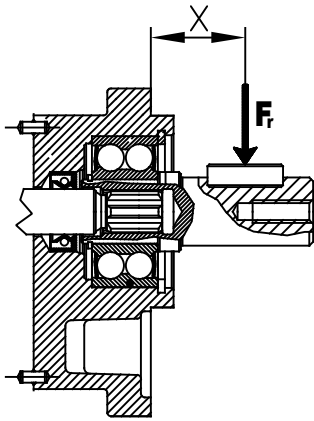

X = Distance of the radial flange result from the mounting flange

**Each curve has been obtained at:
Lubricant oil ISO VG 46
Temperature 60° C (140° F)
Without or with very low axial load**

**Example
Fr = 600 N
X = 20 mm
Speed = 3000 rpm
Rating fatigue life ≈ 2500 h**

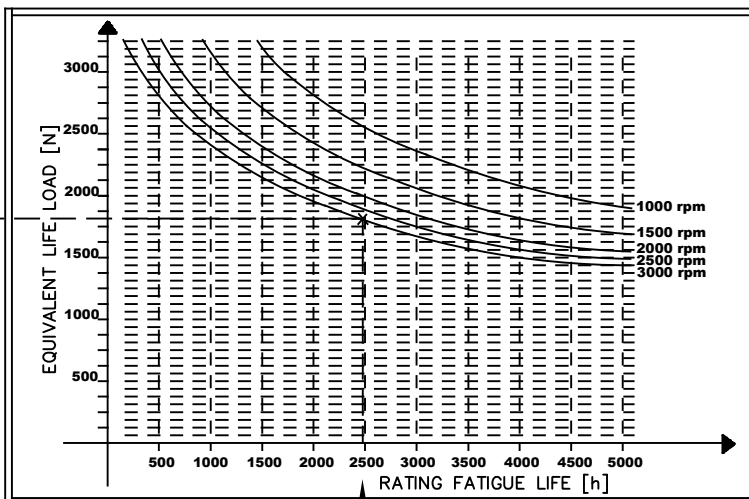
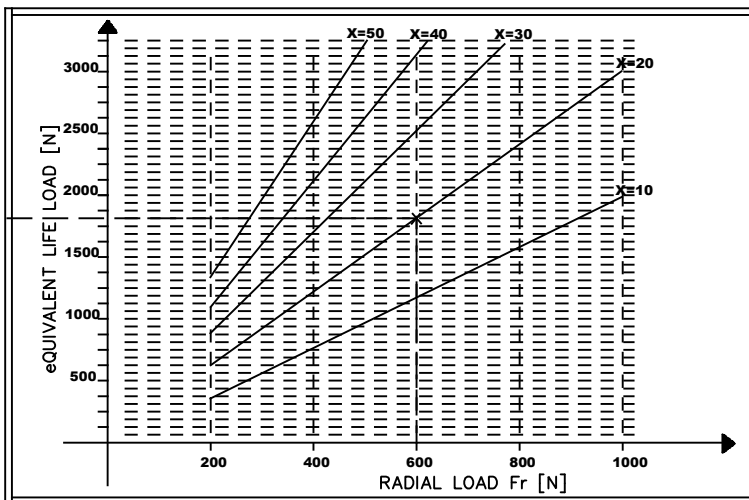



GROUP 1 PUMPS

FLOW CHARACTERISTICS CURVES

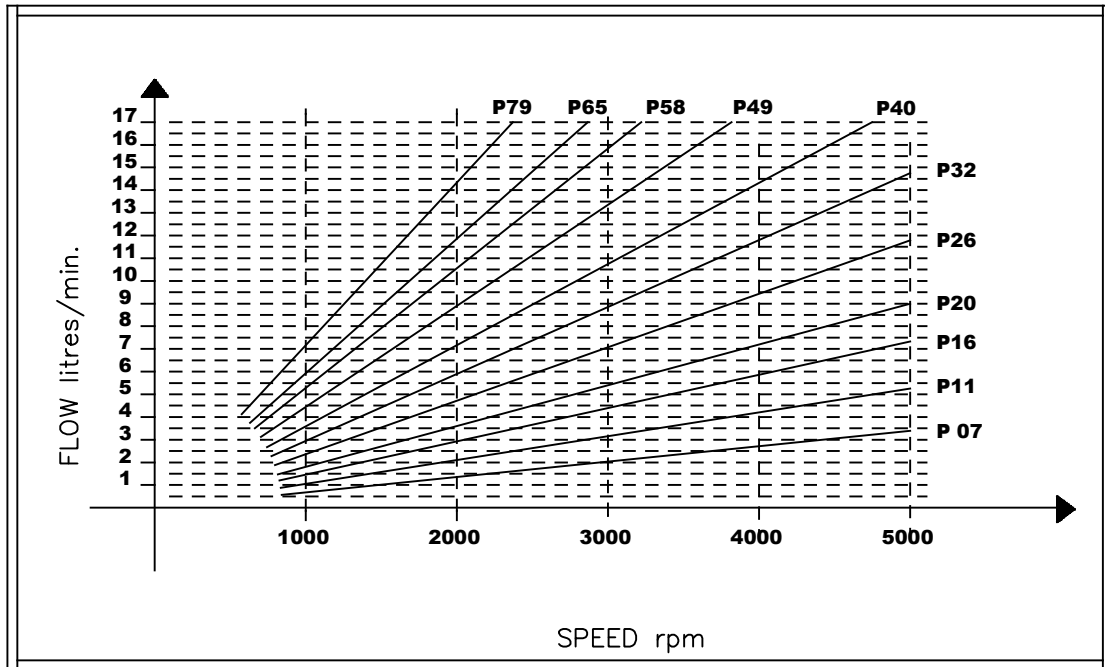

ABSORBED TORQUE

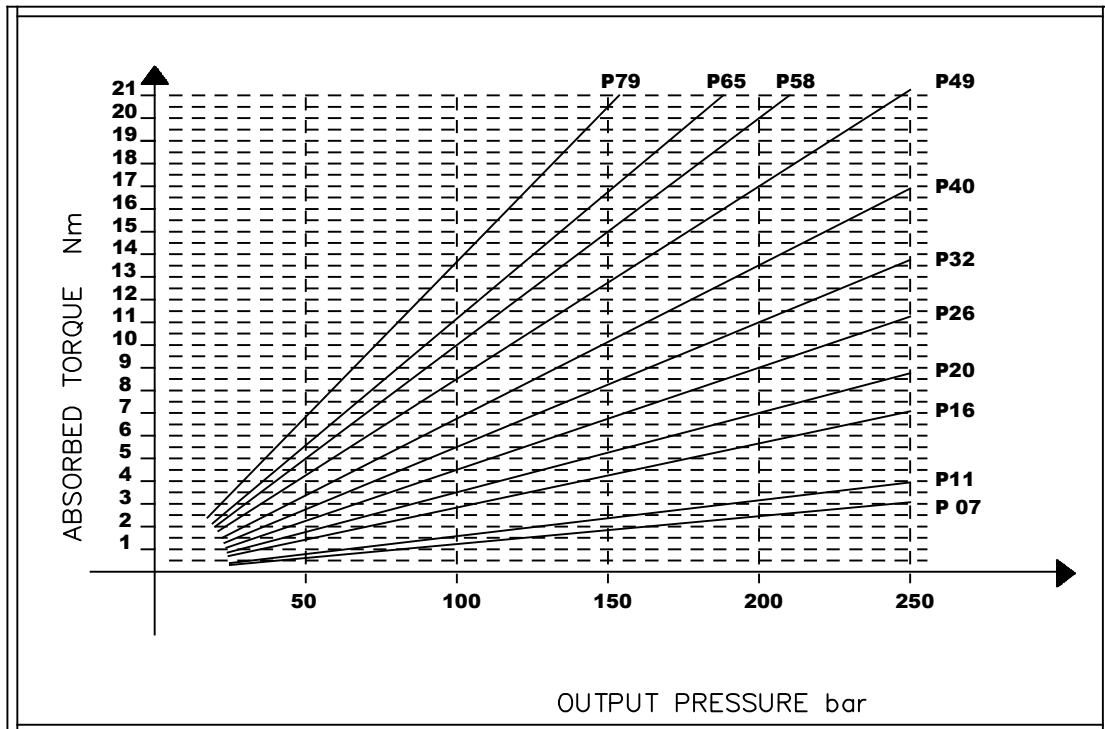

NOTE

Above flow characteristics curves have been made considering a volumetric efficiency of 95%

**GROUP 1 PUMPS****PUMP CALCULATION**

V	Displacement	cc / rev
Q	Flow	l/min
P	Power	kW
C	Torque	N · m
N	Speed	rpm
ΔP	Pressure	bar
n_v	Volumetric efficiency	0.95
n_m	Mechanical efficiency	0.9
n_t	Total efficiency	0.85

$$Q = V_v \cdot n \cdot \frac{N}{10} \quad \text{l/min}$$

$$C = \frac{\Delta P \cdot V}{62.8 \cdot n} \quad \text{N} \cdot \text{m}$$

$$P = \frac{\Delta P \cdot V \cdot N}{612000 \cdot n} \quad \text{kW}$$

GROUP 1 PUMPS - EUROPEAN STANDARD

VERSION: B18 P1

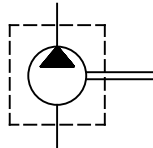
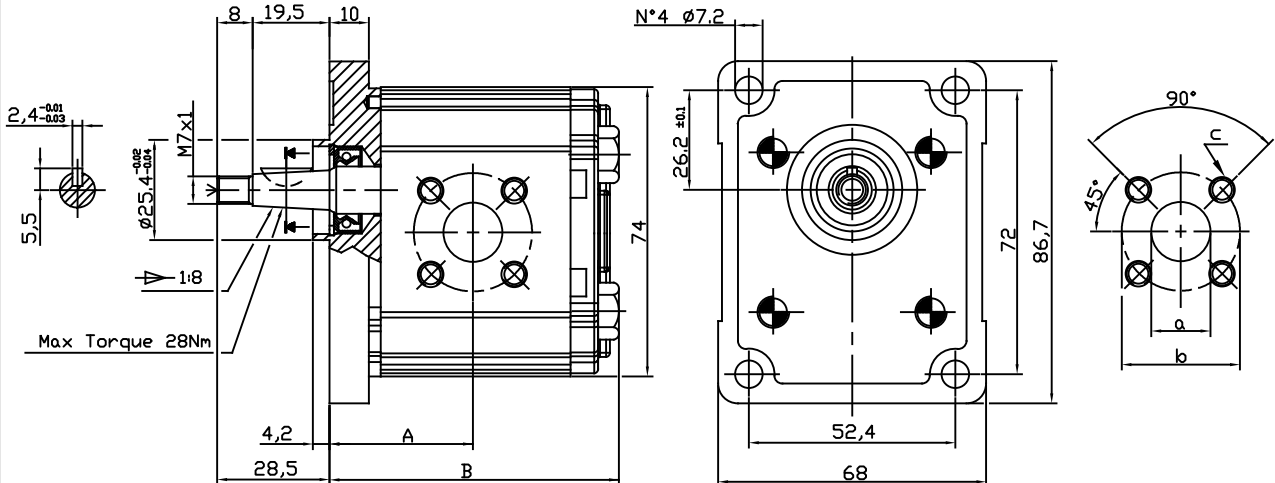

Port	a	b	c
	mm	mm	Thread
Outlet	13	30	M6x12
Inlet	13	30	M6x12

Type	Displacement (cc/rev)	Max working pressure P1 (bar)	Peak pressure P3 (bar)	Max speed (r.p.m)	Dimension A B		Absorbed torque at 150 bar (Nm)	Code (Anti-clockwise)	Code (Clockwise)
					(mm)				
OT 100 P07	0.73	200	240	5000	31.30	64.5	1.8	PS1007081S	PS1007081D
OT 100 P11	1.05	250	290	5000	31.90	65.6	2.4	PS1007082S	PS1007082D
OT 100 P16	1.45	260	300	5000	32.75	67.3	4.2	PS1007083S	PS1007083D
OT 100 P20	1.80	260	300	5000	33.45	68.7	5.2	PS1007084S	PS1007084D
OT 100 P25	2.45	260	300	5000	34.50	70.8	6.7	PS1007085S	PS1007085D
OT 100 P32	3.05	260	300	5000	35.50	72.8	8.3	PS1007086S	PS1007086D
OT 100 P40	3.80	260	300	4500	36.90	75.6	10.1	PS1007087S	PS1007087D
OT 100 P49	4.70	240	280	4500	38.45	78.7	12.7	PS1007088S	PS1007088D
OT 100 P58	5.55	200	240	4000	40.00	81.8	15.0	PS1007089S	PS1007089D
OT 100 P65	6.25	190	230	3750	41.25	84.3	16.8	PS1007090S	PS1007090D
OT 100 P79	7.60	170	220	3500	43.60	89.0	20.5	PS1017091S	PS1017091D

EXAMPLE OF ORDERING CODE

OT100 P 20 S / B 18 P1

Series

Pump

Displacement (see above table)

Rotation

S Anti-clockwise

D Clockwise

European standard flange

Taper shaft (1:8)

Body for European flanges

AVAILABLE FOR QUANTITIES

GROUP 1 PUMPS - EUROPEAN STANDARD

VERSION: G18 P1

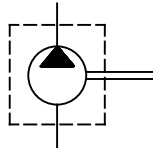
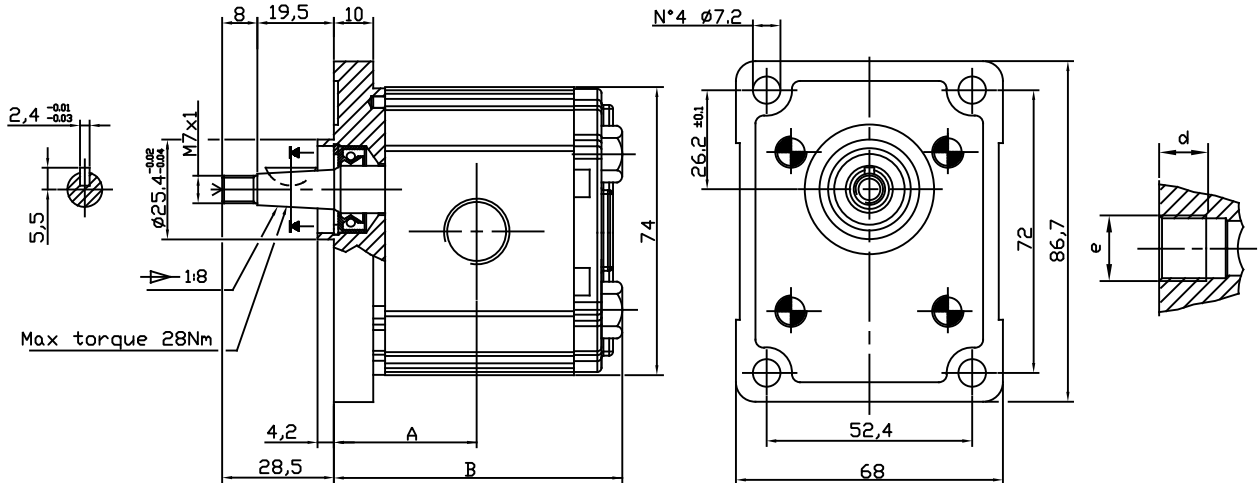

Port	Dimension	e	d
Outlet	3/8"	G 3/8"	14
Inlet	3/8"	G 3/8"	14

Type	Displacement (cc/rev)	Max working pressure P1 (bar)	Peak pressure P3 (bar)	Max speed (r.p.m)	Dimension (mm)		Absorbed torque at 150 bar (Nm)	Code (Anti-clockwise)	Code (Clockwise)
					A	B			
OT 100 P07	0.73	200	240	5000	31.30	64.5	1.8	PS1007061S	PS1007061D
OT 100 P11	1.05	240	280	5000	31.90	65.6	2.4	PS1007062S	PS1007062D
OT 100 P16	1.45	260	300	5000	32.75	67.3	4.2	PS1007063S	PS1007063D
OT 100 P20	1.80	260	300	5000	33.45	68.7	5.2	PS1007064S	PS1007064D
OT 100 P25	2.45	260	300	5000	34.50	70.8	6.7	PS1007065S	PS1007065D
OT 100 P32	3.05	260	300	5000	35.50	72.8	8.3	PS1007066S	PS1007066D
OT 100 P40	3.80	260	300	4500	36.90	75.6	10.1	PS1007067S	PS1007067D
OT 100 P49	4.70	240	280	4500	38.45	78.7	12.7	PS1007068S	PS1007068D
OT 100 P58	5.55	200	240	4000	40.00	81.8	15.0	PS1007069S	PS1007069D
OT 100 P65	6.25	190	230	3750	41.25	84.3	16.8	PS1007070S	PS1007070D
OT 100 P79	7.60	170	220	3500	43.60	89.0	20.5	PS1017071S	PS1017071D

EXAMPLE OF ORDERING CODE

OT100 P 20 S / G 18 P1

Series

Pump

Displacement (see above table)

Rotation

S Anti-clockwise

D Clockwise

European standard flange

Taper shaft (1:8)

Body with threaded ports (BSP)

AVAILABLE FOR QUANTITIES

GROUP 1 PUMPS - EUROPEAN STANDARD

VERSION: G2 18 P1

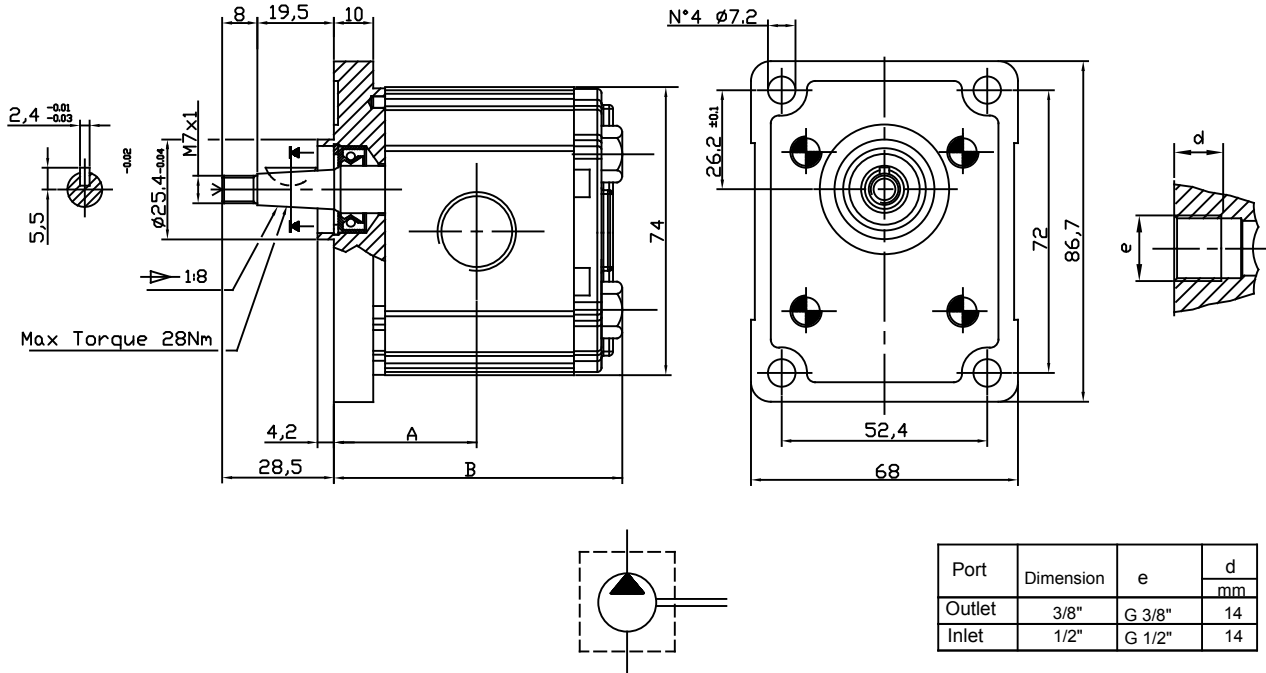

Type	Displacement (cc/rev)	Max working pressure P1 (bar)	Peak pressure P3 (bar)	Max speed (r.p.m)	Dimension A B		Absorbed torque at 150 bar (Nm)	Code (Anti-clockwise)	Code (Clockwise)
					(mm)				
OT 100 P49	4.70	240	280	4500	38.45	78.7	12.7	OT100 M79	PS1027035D
OT 100 P58	5.55	200	240	4000	40.00	81.8	15.0	PS1027036S	PS1027036D
OT 100 P65	6.25	190	230	3750	41.25	84.3	16.8	PS1027037S	PS1027037D
OT 100 P79	7.60	170	220	3500	43.60	89.0	20.5	PS1027038S	PS1027038D

EXAMPLE OF ORDERING CODE

OT100 P 65 S / G2 18 P1

Series

Pump

Displacement (see above table)

Rotation

S Anti-clockwise

D Clockwise

European standard flange

Taper shaft (1:8)

Body with threaded ports (BSP)
Inlet G 1/2"

AVAILABLE FOR QUANTITIES

GROUP 1 PUMPS - FOR POWER UNITS

VERSION: N14 B2

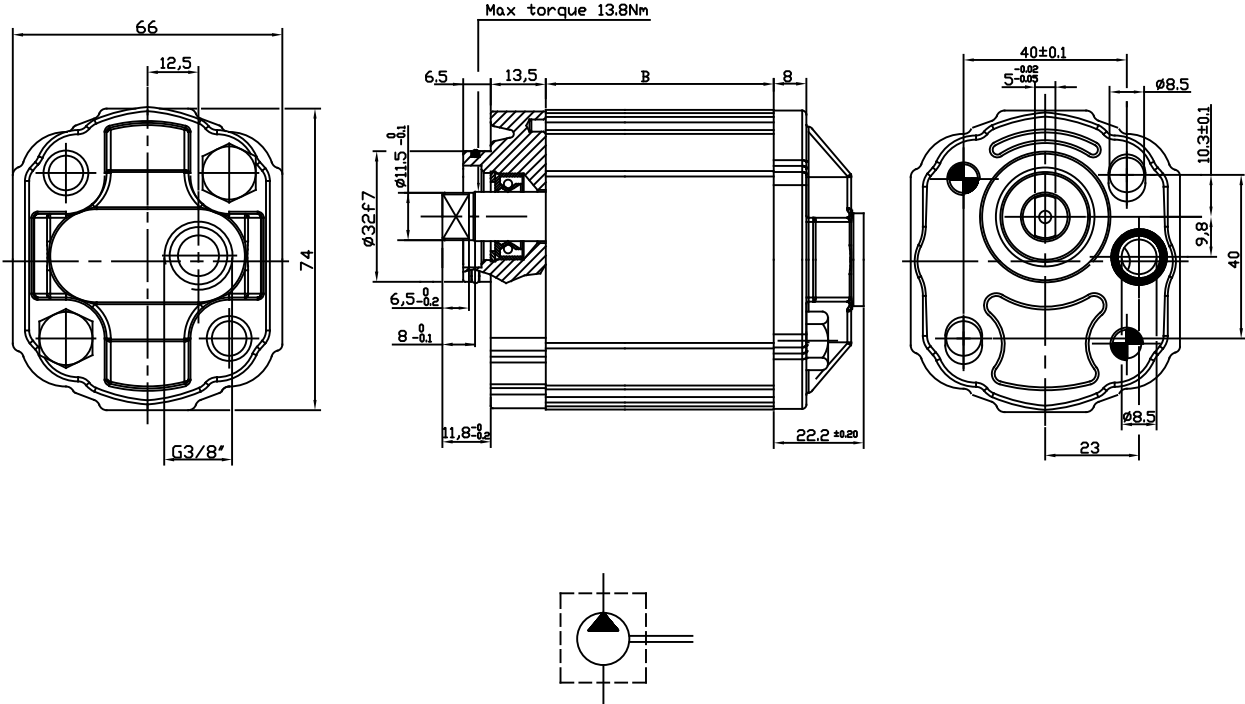

Type	Displacement (cc/rev)	Max working pressure P1 (bar)	Peak pressure P3 (bar)	Max speed (rpm)	Dimension B (mm)	Absorbed torque at 150 bar (Nm)	Code (Clockwise)
OT 100 P07	0.73	200	240	5000	36.7	1.8	PS1007001D
OT 100 P11	1.05	240	280	5000	37.8	2.4	PS1007002D
OT 100 P16	1.45	260	300	5000	39.5	4.2	PS1007003D
OT 100 P20	1.80	240	300	5000	40.9	5.2	PS1007004D
OT 100 P26	2.45	240	280	5000	43.0	6.7	PS1007005D
OT 100 P32	3.05	240	280	5000	45.0	8.3	PS1007006D
OT 100 P40	3.80	220	260	4500	47.8	10.1	PS1007007D
OT 100 P49	4.70	200	240	4500	50.9	12.7	PS1007008D
OT 100 P58	5.55	180	220	4000	54.0	15.0	PS1007009D
OT 100 P65	6.25	160	200	3750	56.5	16.8	PS1007010D
OT 100 P79	7.60	140	180	3500	61.2	20.5	PS1017001D

EXAMPLE OF ORDERING CODE

OT100 P 20 D / N 14 B2

Series

Pump

Displacement (see above table)

Rotation

D clockwise

B2= Flange for clockwise

Tang shaft

Body without ports

NOTE

☐ Screws tightening torque : 25 ± 28 Nm

GROUP 1 PUMPS - FOR POWER UNITS

VERSION: N14 B1

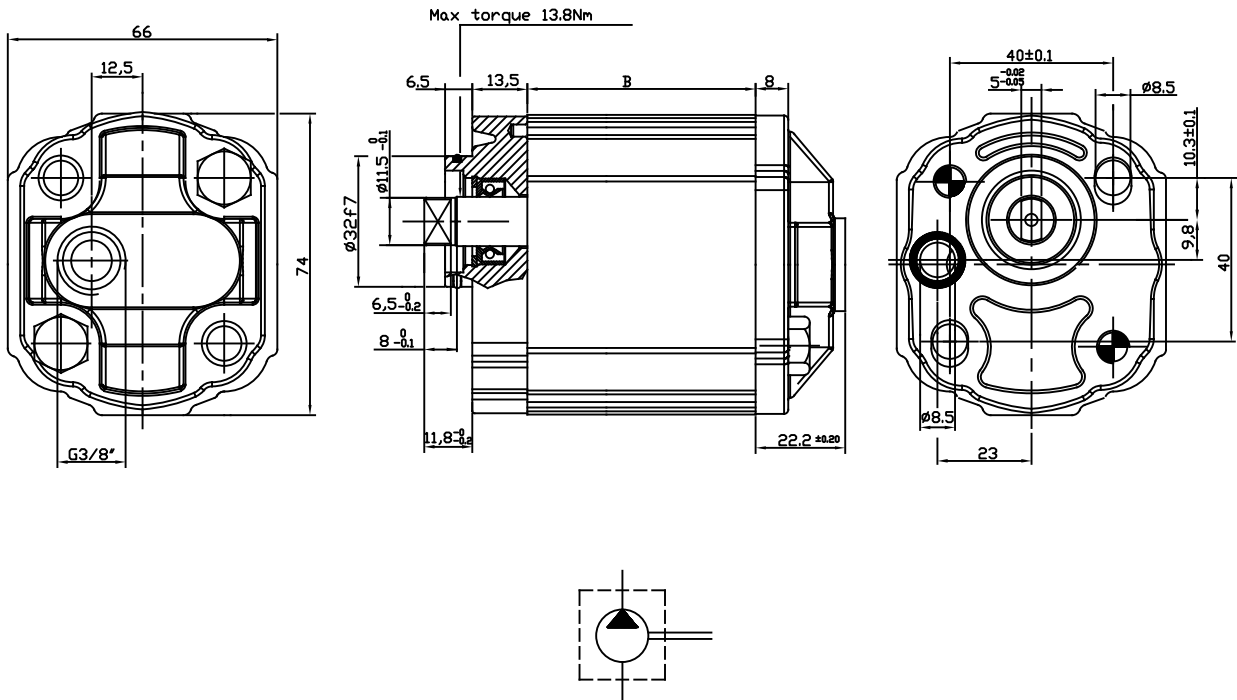

Type	Displacement (cc/rev)	Max working pressure P1 (bar)	Peak pressure P3 (bar)	Max speed (rpm)	Dimension B (mm)	Absorbed torque at 150 bar (Nm)	Code (Anti- Clockwise)
OT 100 P07	0.73	200	240	5000	36.7	1.8	PS1007001S
OT 100 P11	1.05	240	280	5000	37.8	2.4	PS1007002S
OT 100 P16	1.45	260	300	5000	39.5	4.2	PS1007003S
OT 100 P20	1.80	240	300	5000	40.9	5.2	PS1007004S
OT 100 P26	2.45	240	280	5000	43.0	6.7	PS1007005S
OT 100 P32	3.05	240	280	5000	45.0	8.3	PS1007006S
OT 100 P40	3.80	220	260	4500	47.8	10.1	PS1007007S
OT 100 P49	4.70	200	240	4500	50.9	12.7	PS1007008S
OT 100 P58	5.55	180	220	4000	54.0	15.0	PS1007009S
OT 100 P65	6.25	160	200	3750	56.5	16.8	PS1007010S
OT 100 P79	7.60	140	180	3500	61.2	20.5	PS1017001S

EXAMPLE OF ORDERING CODE

OT100 P 20 S / N 14 B1

Series

Pump

Displacement (see above table)

Rotation

S Anti-clockwise

B1= Flange for Anti-clockwise

Tang shaft

Body without ports

NOTE

Screws tightening torque : 25 ± 28 Nm

GROUP 1 PUMPS - FOR POWER UNITS

VERSION: N16 B2

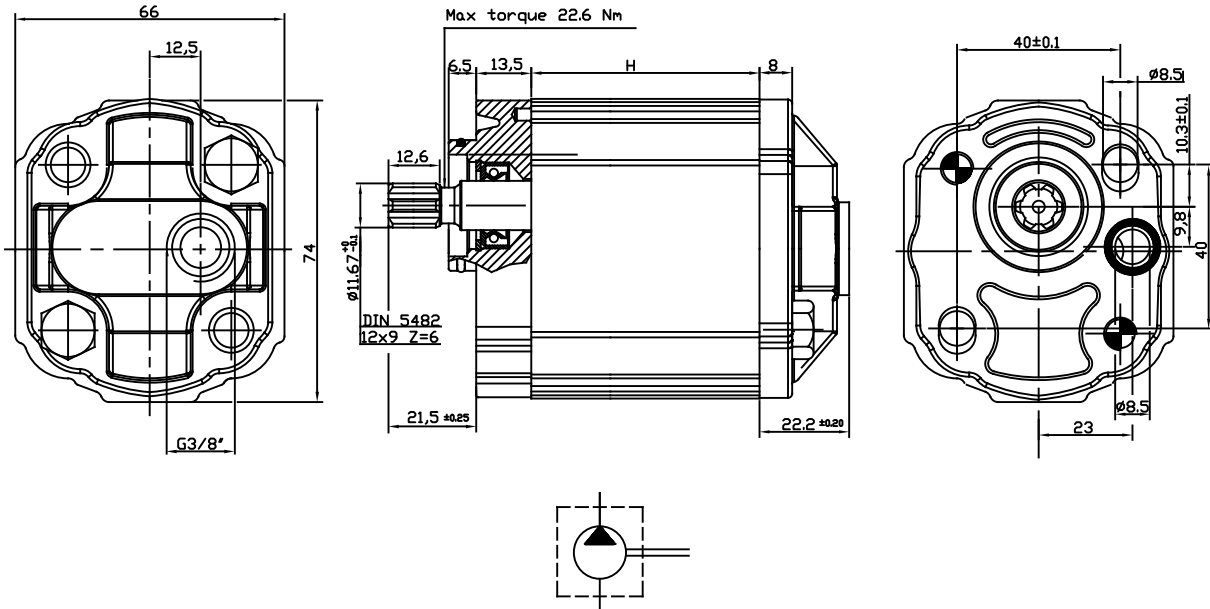

Type	Displacement (cc/rev)	Max working pressure P1 (bar)	Peak pressure P3 (bar)	Max speed (rpm)	Dimension B (mm)	Absorbed torque at 150 bar (Nm)	Code (Clockwise)
OT 100 P07	0.73	200	240	5000	36.7	1.8	PS1007101D
OT 100 P11	1.05	240	280	5000	37.8	2.3	PS1007102D
OT 100 P13	1.25	240	280	5000	38.5	2.5	PS1007102D
OT 100 P16	1.45	260	300	5000	39.5	4.2	PS1007103D
OT 100 P20	1.80	240	300	5000	40.9	5.2	PS1007104D
OT 100 P26	2.50	240	280	5000	43.0	6.7	PS1007105D
OT 100 P32	3.05	240	280	5000	45.0	8.3	PS1007106D
OT 100 P40	3.80	220	260	4500	47.8	10.1	PS1007107D
OT 100 P43	4.30	200	240	4500	49.5	12.0	PS1027075D
OT 100 P49	4.70	200	240	4500	50.9	12.7	PS1007108D
OT 100 P58	5.55	180	220	4000	54.0	15.0	PS1007109D
OT 100 P65	6.25	160	200	3750	56.5	16.8	PS1007110D
OT 100 P79	7.60	140	180	3500	61.2	20.5	PS1017111D
OT 100 P99	9.70	130	170	3500	70.0	26.3	PS1027082D

EXAMPLE OF ORDERING CODE

OT100 P 20 D / N 16 B2

kW
Series

Pump

displacement (see above table)

Rotation

D Clockwise

B2= Flange for clockwise

Splined shaft (DIN5482)

Body without ports

NOTE

□ Screws tightening torque : 25 ± 28 Nm

GROUP 1 PUMPS - FOR POWER UNITS

VERSION: G13B0

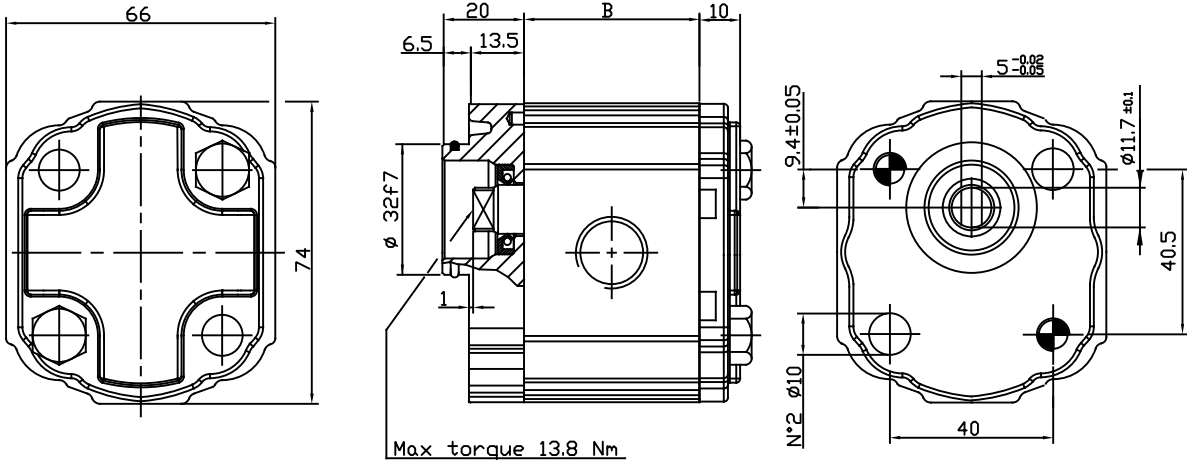

Max torque 13.8 Nm

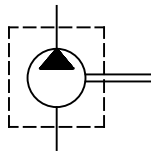
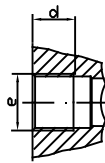

Port	Dimension	e	d
Outlet	3/8"	G 3/8"	14
Inlet	3/8"	G 3/8"	14

Type	Displacement (cc/ rev)	Max working pressure P1 (bar)	Peak pressure P3 (bar)	Max speed (rpm)	Dimension B (mm)	Absorbed torque at 150 bar (Nm)	Code (Anti-clockwise)	Code (Clockwise)
OT 100 P07	0.73	200	240	5000	36.7	1.8	PS1007031S	PS1007031D
OT 100 P11	1.05	240	280	5000	37.8	2.4	PS1007032S	PS1007032D
OT 100 P16	1.45	260	300	5000	39.5	4.2	PS1007033S	PS1007033D
OT 100 P20	1.80	240	300	5000	40.9	5.2	PS1007034S	PS1007034D
OT 100 P26	2.50	240	280	5000	43.0	6.7	PS1007035S	PS1007035D
OT 100 P32	3.05	240	280	5000	45.0	8.3	PS1007036S	PS1007036D
OT 100 P40	3.80	220	260	4500	47.8	10.1	PS1007037S	PS1007037D
OT 100 P49	4.70	200	240	4500	50.9	12.7	PS1007038S	PS1007038D
OT 100 P58	5.55	180	220	4000	54.0	15.0	PS1007039S	PS1007039D
OT 100 P65	6.25	160	200	3750	56.5	16.8	PS1007040S	PS1007040D
OT 100 P79	7.60	140	180	3500	61.2	20.5	PS1017031S	PS1017031D

EXAMPLE OF ORDERING CODE

OT100 P 20 S / G 13 B0

Series

Pump

displacement (see above table)

Rotation

S	Anti-clockwise
D	Clockwise

Neutral flange

Tang shaft short type

Body with threaded ports (BSP)

NOTE

Screws tightening torque : 25 ± 28 Nm

AVAILABLE FOR QUANTITIES

GROUP 1 PUMPS - FOR POWER UNITS

VERSION : G14B0

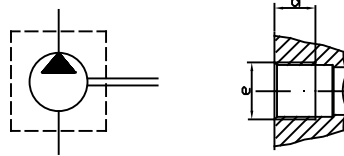
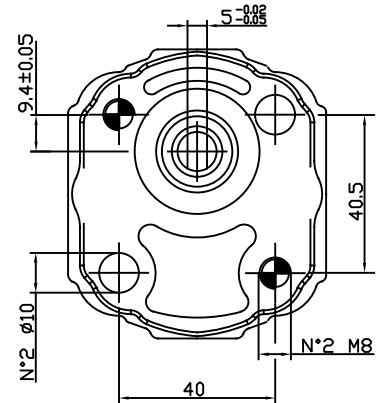
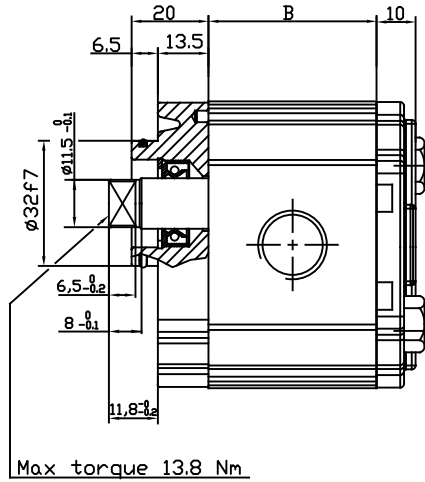
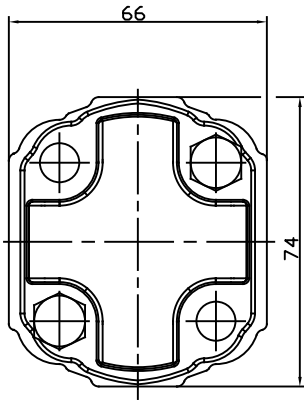

Port	Dimension	e	d
Outlet	3/8"	G 3/8"	14
Inlet	3/8"	G 3/8"	14

Type	Displacement (cc/ rev)	Max working pressure P1 (bar)	Peak pressure P3 (bar)	Max speed (rpm)	Dimension B (mm)	Absorbed torque at 150 bar (Nm)	Code (Anti-clockwise)	Code (Clockwise)
OT 100 P07	0.73	200	240	5000	36.7	1.8	PS1007031S	PS1007031D
OT 100 P11	1.05	240	280	5000	37.8	2.4	PS1007032S	PS1007032D
OT 100 P16	1.45	260	300	5000	39.5	4.2	PS1007033S	PS1007033D
OT 100 P20	1.80	240	300	5000	40.9	5.2	PS1007034S	PS1007034D
OT 100 P26	2.50	240	280	5000	43.0	6.7	PS1007035S	PS1007035D
OT 100 P32	3.05	240	280	5000	45.0	8.3	PS1007036S	PS1007036D
OT 100 P40	3.80	220	260	4500	47.8	10.1	PS1007037S	PS1007037D
OT 100 P49	4.70	200	240	4500	50.9	12.7	PS1007038S	PS1007038D
OT 100 P58	5.55	180	220	4000	54.0	15.0	PS1007039S	PS1007039D
OT 100 P65	6.25	160	200	3750	56.5	16.8	PS1007040S	PS1007040D
OT 100 P79	7.60	140	180	3500	61.2	20.5	PS1017031S	PS1017031D

EXAMPLE OF ORDERING CODE

OT100 P 20 S / G 14 B0

Series

Pump

displacement (see above table)

Rotation

S Anti-clockwise

D Clockwise

Neutral flange

Tang shaft

Body with threaded ports (BSP)

NOTE

☐ Screws tightening torque : 25 ± 28 Nm

GROUP 1 PUMPS - FOR POWER UNITS

VERSION : G2 14B0

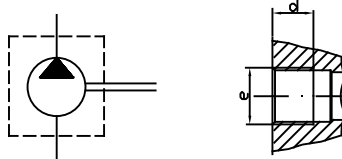
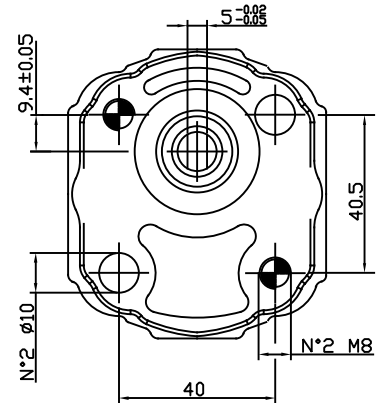
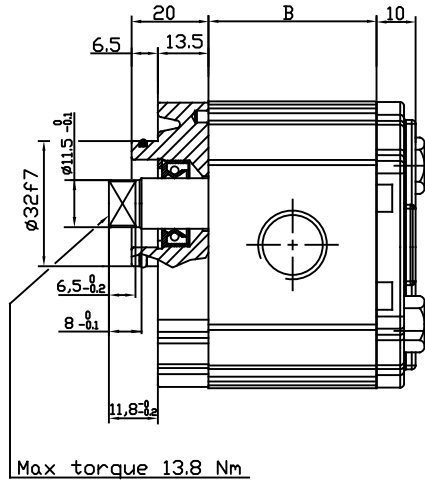
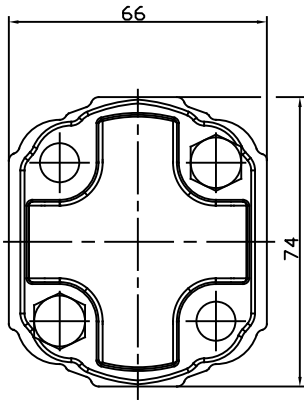

Port	Dimension	e	d
			mm
Outlet	3/8"	G 3/8"	14
Inlet	1/2"	G 1/2"	14

Type	Displacement (cc/rev)	Max working pressure P1 (bar)	Peak pressure P3 (bar)	Max speed (r.p.m)	Dimension		Absorbed torque at 150 bar (Nm)	Code (Anti-clockwise)	Code (Clockwise)
					A	B			
					(mm)			OT100 M79	
OT 100 P49	4.70	240	280	4500	38.45	78.7	12.7	PS1027035S	PS1027035D
OT 100 P58	5.55	200	240	4000	40.00	81.8	15.0	PS1027036S	PS1027036D
OT 100 P65	6.25	190	230	3750	41.25	84.3	16.8	PS1027037S	PS1027037D
OT 100 P79	7.60	170	220	3500	43.60	89.0	20.5	PS1027038S	PS1027038D

EXAMPLE OF ORDERING CODE

OT100 P 58 S / G2 14 B0

Series

Pump

displacement (see above table)

Rotation

S Anti-clockwise

D Clockwise

Neutral flange

Tang shaft

Body with threaded ports (BSP)
Inlet G 1/2"

NOTE

Screws tightening torque : 25 ± 28 Nm

GROUP 1 PUMPS - SAE "AA" STANDARD

VERSION: R11S1

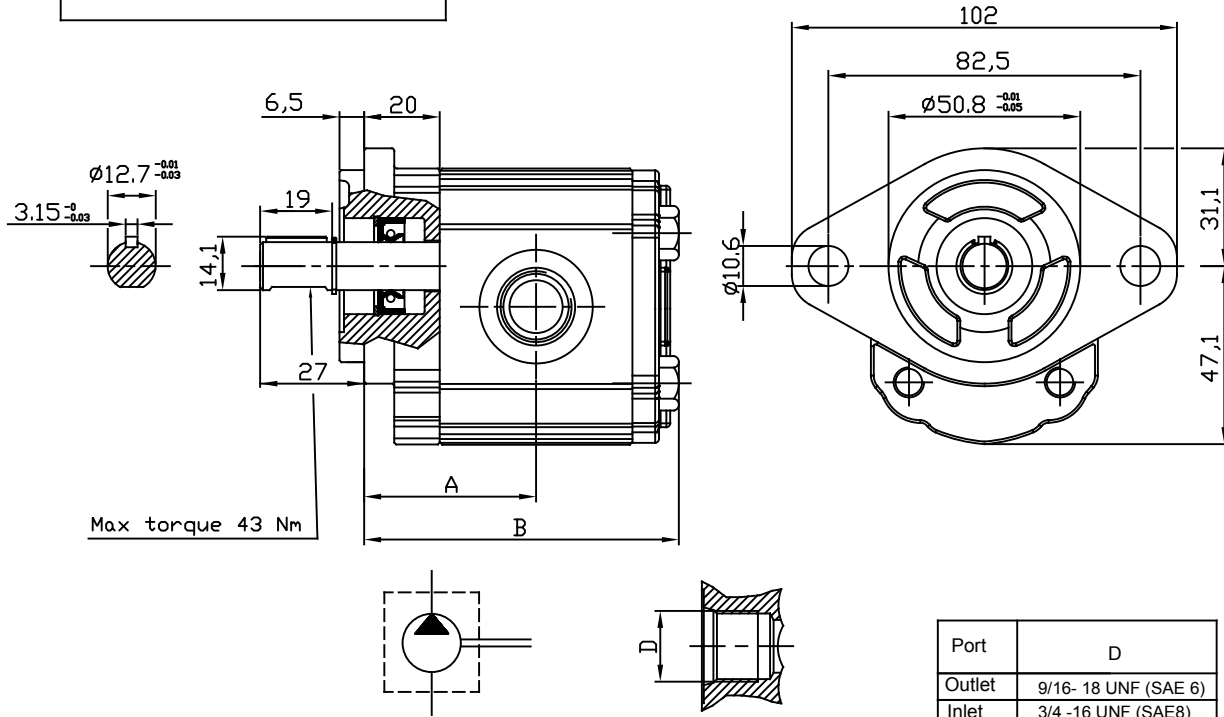

Max torque 43 Nm

Type	Displacement (cc/rev)	Max working pressure P1 (bar)	Peak pressure P3 (bar)	Max speed (r.p.m)	Dimension A B		Absorbed torque at 150 bar (Nm)	Code (Anti-clockwise)	Code (Clockwise)
					(mm)				
OT 100 P07	0.73	200	240	5000	38.35	69.00	1.8	PS1007120S	PS1007120D
OT 100 P11	1.05	240	280	5000	38.90	70.10	2.4	PS1007121S	PS1007121D
OT 100 P16	1.55	260	300	5000	39.75	71.80	4.2	PS1007122S	PS1007122D
OT 100 P20	1.90	260	300	5000	40.45	72.75	5.2	PS1007123S	PS1007123D
OT 100 P25	2.50	260	300	5000	41.50	75.30	6.7	PS1007124S	PS1007124D
OT 100 P32	3.10	260	300	5000	42.50	77.30	8.3	PS1007125S	PS1007125D
OT 100 P40	3.80	260	300	4500	43.90	80.10	10.1	PS1007126S	PS1007126D
OT 100 P49	4.70	240	280	4500	45.45	83.20	12.7	PS1007127S	PS1007127D
OT 100 P58	5.55	200	240	4000	47.00	86.30	15.0	PS1007128S	PS1007128D
OT 100 P65	6.25	190	230	3750	48.25	88.80	16.8	PS1007129S	PS1007129D
OT 100 P79	7.60	170	220	3500	50.60	93.50	20.5	PS1007130S	PS1007130D

EXAMPLE OF ORDERING CODE

OT100 P 20 S / R 11 S1

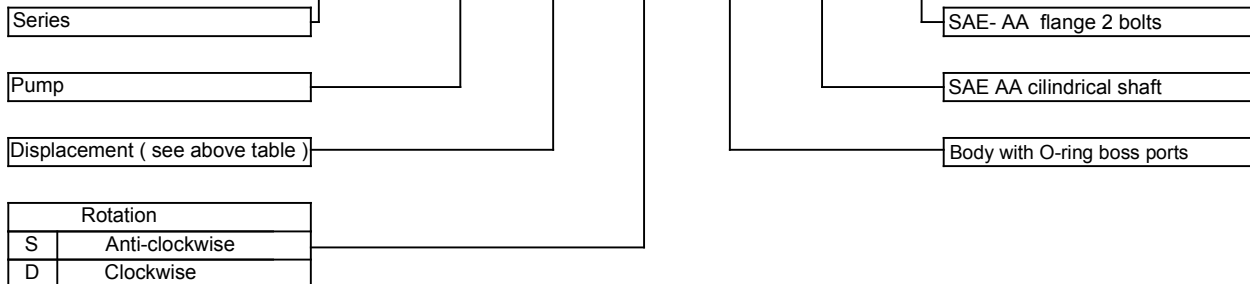

AVAILABLE FOR QUANTITIES

GROUP 1 PUMPS - SAE "AA" STANDARD

VERSION: G11S1

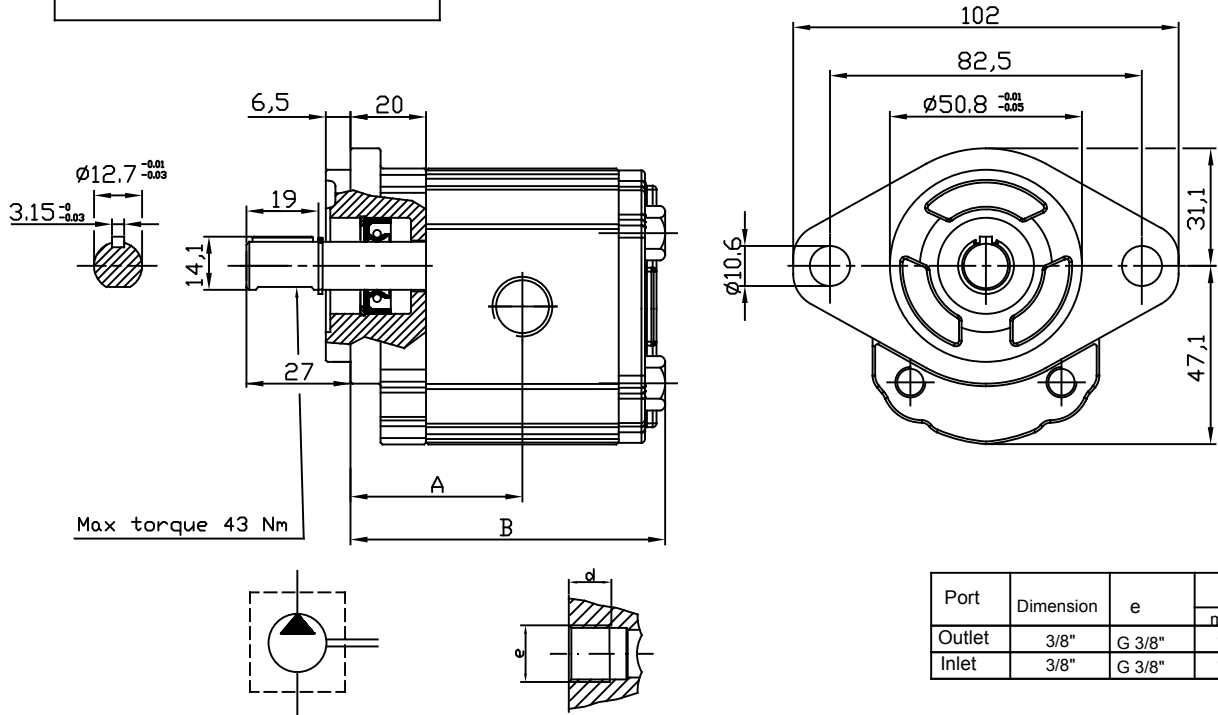

Port	Dimension	e	d
Outlet	3/8"	G 3/8"	14
Inlet	3/8"	G 3/8"	14

Type	Displacement (cc/rev)	Max working pressure P1 (bar)	Peak pressure P3 (bar)	Max speed (r.p.m)	Dimension A B		Absorbed torque at 150 bar (Nm)	Code (Anti-clockwise)	Code (Clockwise)
					(mm)				
OT 100 P07	0.73	200	240	5000	38.35	69.00	1.8	PS1007131S	PS1007131D
OT 100 P11	1.05	240	280	5000	38.90	70.10	2.4	PS1007132S	PS1007132D
OT 100 P16	1.55	260	300	5000	39.75	71.80	4.2	PS1007133S	PS1007133D
OT 100 P20	1.90	260	300	5000	40.45	72.75	5.2	PS1007134S	PS1007134D
OT 100 P25	2.50	260	300	5000	41.50	75.30	6.7	PS1007135S	PS1007135D
OT 100 P32	3.10	260	300	5000	42.50	77.30	8.3	PS1007136S	PS1007136D
OT 100 P40	3.80	260	300	4500	43.90	80.10	10.1	PS1007137S	PS1007137D
OT 100 P49	4.70	240	280	4500	45.45	83.20	12.7	PS1007138S	PS1007138D
OT 100 P58	5.55	200	240	4000	47.00	86.30	15.0	PS1007139S	PS1007139D
OT 100 P65	6.25	190	230	3750	48.25	88.80	16.8	PS1007140S	PS1007140D
OT 100 P79	7.60	170	220	3500	50.60	93.50	20.5	PS1007141S	PS1007141D

EXAMPLE OF ORDERING CODE

OT100 P 20 S / G 11 S1

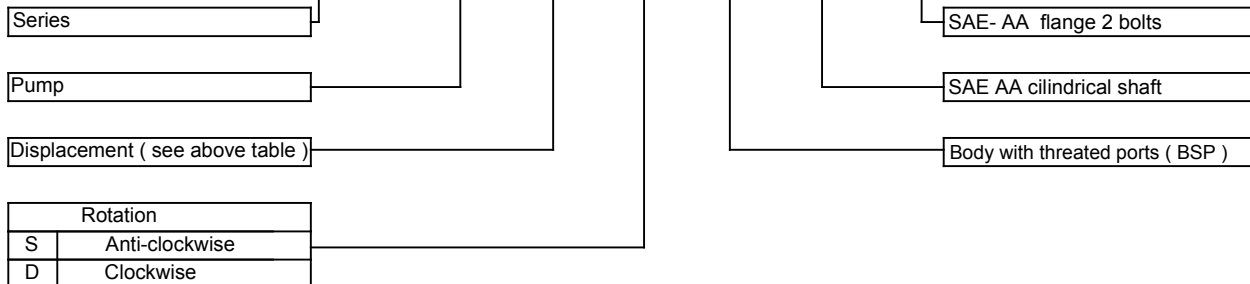

AVAILABLE FOR QUANTITIES

GROUP 1 PUMPS - SAE "AA" STANDARD

VERSION: B11 S1

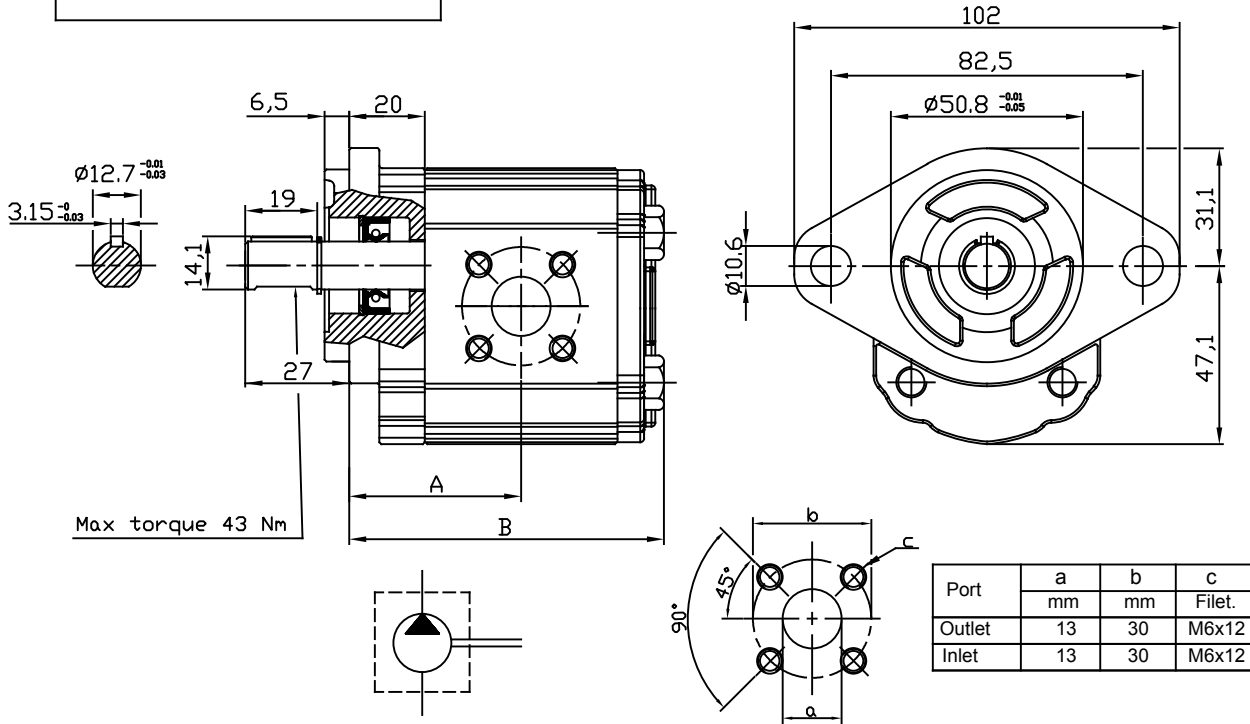

Max torque 43 Nm

Type	Displacement (cc/rev)	Max working pressure P1 (bar)	Peak pressure P3 (bar)	Max speed (r.p.m)	Dimension A B		Absorbed torque at 150 bar (Nm)	Code (Anti-clockwise)	Code (Clockwise)
					(mm)				
OT 100 P07	0.73	200	240	5000	38.35	69.00	1.8	PS1007142S	PS1007142D
OT 100 P11	1.05	240	280	5000	38.90	70.10	2.4	PS1007143S	PS1007143D
OT 100 P16	1.55	260	300	5000	39.75	71.80	4.2	PS1007144S	PS1007144D
OT 100 P20	1.90	260	300	5000	40.45	72.75	5.2	PS1007145S	PS1007145D
OT 100 P25	2.50	260	300	5000	41.50	75.30	6.7	PS1007146S	PS1007146D
OT 100 P32	3.10	260	300	5000	42.50	77.30	8.3	PS1007147S	PS1007147D
OT 100 P40	3.80	260	300	4500	43.90	80.10	10.1	PS1007148S	PS1007148D
OT 100 P49	4.70	240	280	4500	45.45	83.20	12.7	PS1007149S	PS1007149D
OT 100 P58	5.55	200	240	4000	47.00	86.30	15.0	PS1007150S	PS1007150D
OT 100 P65	6.25	190	230	3750	48.25	88.80	16.8	PS1007151S	PS1007151D
OT 100 P79	7.60	170	220	3500	50.60	93.50	20.5	PS1007152S	PS1007152D

EXAMPLE OF ORDERING CODE

OT100 P 20 S / B 11 S1

Series

Pump

Displacement (see above table)

Rotation

S Anti-clockwise

D Clockwise

SAE- AA flange 2 bolts

SAE AA cilindrical shaft

Body for European flanges



AVAILABLE FOR QUANTITIES

GROUP 1 PUMPS - WITH FRONT BEARING

VERSION: B16 T P1

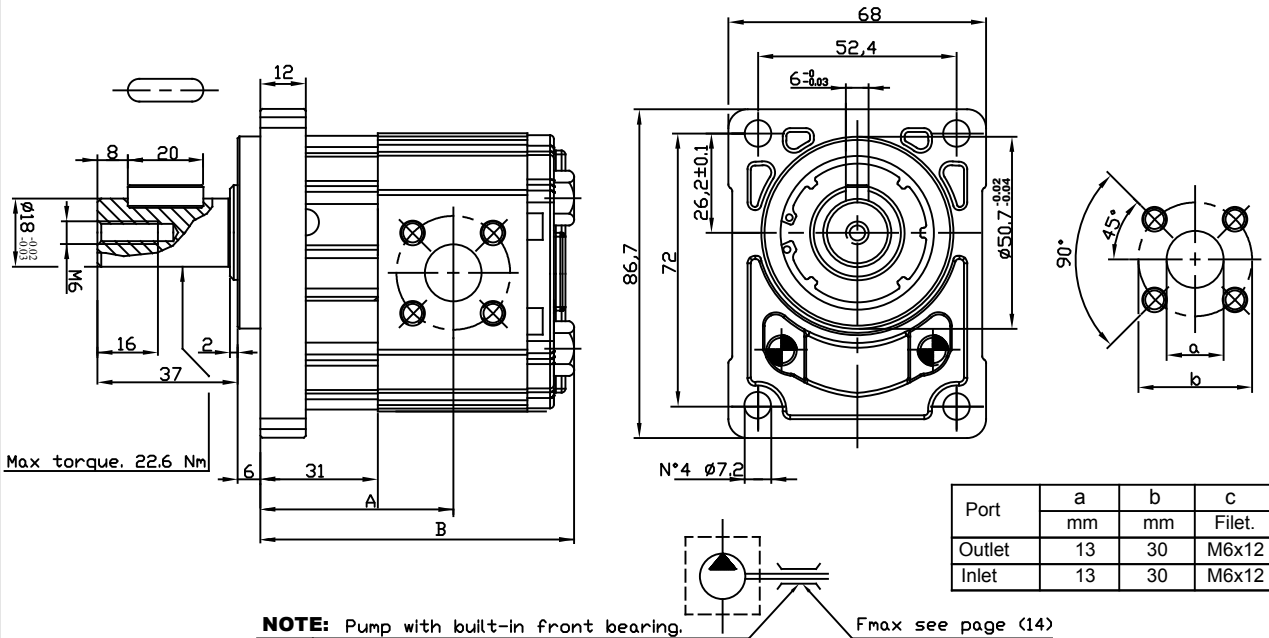

Type	Displacement (cc/rev)	Max working pressure P ₁ (bar)	Peak pressure P ₃ (bar)	Max speed (r.p.m)	Dimension (mm)		Absorbed torque at 150 bar (Nm)	Code (Anti-clockwise)	Code (Clockwise)
					A	B			
OT 100 P07	0.73	200	240	5000	49.30	82.5	1.8	PS1027101S	PS1027101D
OT 100 P11	1.05	240	280	5000	49.90	83.6	2.4	PS1027102S	PS1027102D
OT 100 P13	1.25	260	300	5000	50.60	84.3	3.2	PS1027125S	PS1027125D
OT 100 P16	1.45	260	300	5000	50.75	85.3	4.2	PS1027103S	PS1027103D
OT 100 P20	1.80	260	300	5000	51.45	86.7	5.2	PS1027104S	PS1027104D
OT 100 P25	2.50	260	300	5000	52.50	88.8	6.7	PS1027105S	PS1027105D
OT 100 P32	3.05	260	300	5000	53.50	90.8	8.3	PS1027106S	PS1027106D
OT 100 P40	3.80	260	300	4500	54.90	93.6	10.1	PS1027107S	PS1027107D
OT 100 P43	4.30	240	280	4500	55.45	95.7	12.0	PS1027124S	PS1027124D
OT 100 P49	4.50	240	280	4500	56.45	96.7	12.7	PS1027108S	PS1027108D
OT 100 P58	5.55	200	240	4000	58.00	99.8	15.0	PS1027109S	PS1027109D
OT 100 P65	6.25	190	230	3750	59.25	102.3	16.8	PS1027110S	PS1027110D
OT 100 P79	7.60	170	220	3500	61.60	107.0	20.5	PS1027111S	PS1027111D
OT 100 P99	9.90	130	170	3500	70.40	115.8	26.3	PS1027123S	PS1027123D

EXAMPLE OF ORDERING CODE

OT100 P 20 S / B / T 16 P1

Series

Pump

Displacement (see above table)

Rotation

S	Anti-clockwise
D	Clockwise

European standard flange

Pump shaft

Front bearing

Body for European flanges



AVAILABLE FOR QUANTITIES

GROUP 1 PUMPS - WITH FRONT BEARING

VERSION: G16 T P1

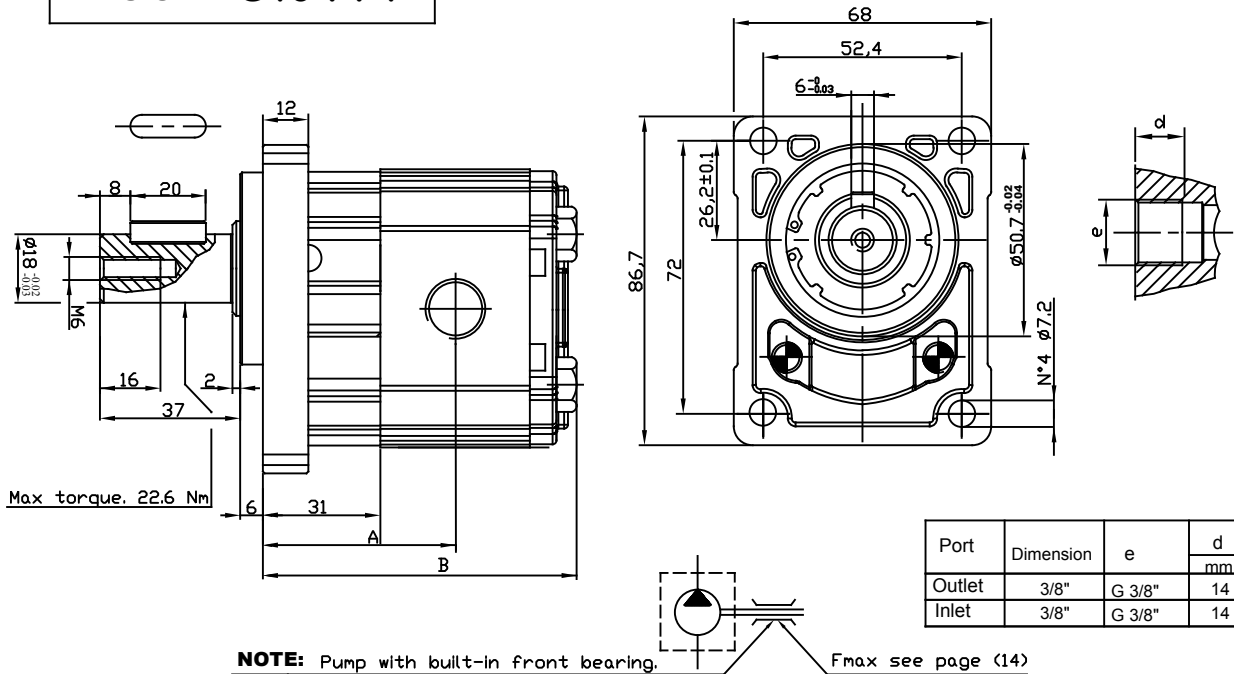

Type	Displacement (cc/rev)	Max working pressure P1 (bar)	Peak pressure P3 (bar)	Max speed (r.p.m)	Dimension		Absorbed torque at 150 bar (Nm)	Code (Anti-clockwise)	Code (Clockwise)
					A	B			
OT 100 P07	0.73	200	240	5000	49.30	82.5	1.8	PS1027112S	PS1027112D
OT 100 P11	1.05	240	280	5000	49.90	83.6	2.4	PS1027113S	PS1027113D
OT 100 P13	1.25	260	300	5000	50.60	84.3	3.2	PS1027128S	PS1027128D
OT 100 P16	1.45	260	300	5000	50.75	85.3	4.2	PS1027114S	PS1027114D
OT 100 P20	1.80	260	300	5000	51.45	86.7	5.2	PS1027115S	PS1027115D
OT 100 P25	2.50	260	300	5000	52.50	88.8	6.7	PS1027116S	PS1027116D
OT 100 P32	3.05	260	300	5000	53.50	90.8	8.3	PS1027117S	PS1027117D
OT 100 P40	3.80	260	300	4500	54.90	93.6	10.1	PS1027118S	PS1027118D
OT 100 P43	4.30	240	280	4500	55.45	95.7	12.0	PS1027127S	PS1027127D
OT 100 P49	4.50	240	280	4500	56.45	96.7	12.7	PS1027119S	PS1027119D
OT 100 P58	5.55	200	240	4000	58.00	99.8	15.0	PS1027120S	PS1027120D
OT 100 P65	6.25	190	230	3750	59.25	102.3	16.8	PS1027121S	PS1027121D
OT 100 P79	7.60	170	220	3500	61.60	107.0	20.5	PS1027122S	PS1027122D
OT 100 P99	9.90	130	170	3500	70.40	115.8	26.3	PS1027126S	PS1027126D

EXAMPLE OF ORDERING CODE

OT100 P 20 S / G / T 16 P1

Series

Pump

Displacement (see above table)

Rotation

S	Anti-clockwise
D	Clockwise

European standard flange

Pump shaft

Front bearing

Body with threaded ports (BSP)



AVAILABLE FOR QUANTITIES

GROUP 1 REVERSIBLE PUMPS - EUROPEAN STANDARD

VERSION: B18 P1

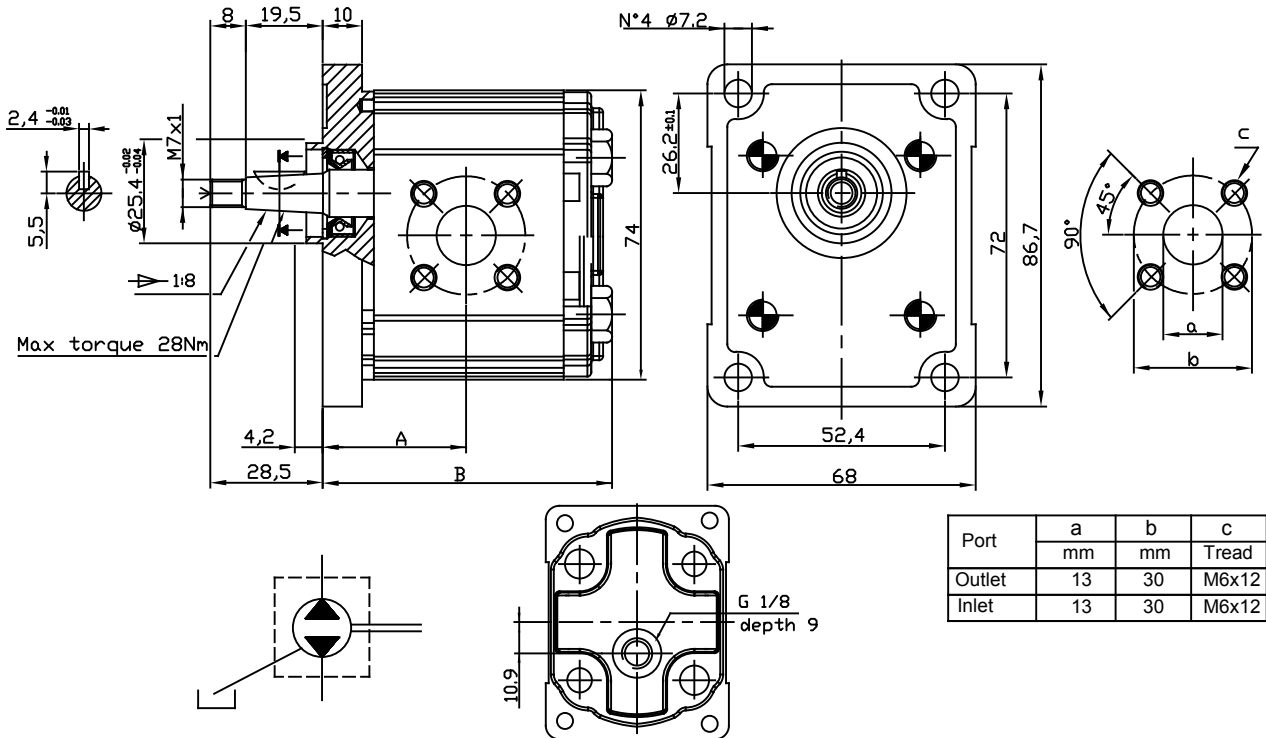

Type	Displacement (cc/rev)	Max working pressure P1 (bar)	Peak pressure P3 (bar)	Max speed (r.p.m)	Dimension A B (mm)		Absorbed torque at 150 bar (Nm)	Code
					A	B		
OT 100 P16	1.45	180	230	5000	32.75	67.3	4.2	PS1007083R
OT 100 P20	1.80	210	250	5000	33.45	68.7	5.2	PS1007084R
OT 100 P25	2.45	210	250	5000	34.50	70.8	6.7	PS1007085R
OT 100 P32	3.05	210	250	5000	35.50	72.8	8.3	PS1007086R
OT 100 P40	3.80	210	250	4500	36.90	75.6	10.1	PS1007087R
OT 100 P49	4.70	200	240	4500	38.45	78.7	12.7	PS1007088R
OT 100 P58	5.55	200	220	4000	40.00	81.8	15.0	PS1007089R
OT 100 P65	6.25	180	210	3750	41.25	84.3	16.8	PS1007090R
OT 100 P79	7.60	160	200	3500	43.60	89.0	20.5	PS1017091R

EXAMPLE OF ORDERING CODE

OT100 P 20 R / B 18 P1

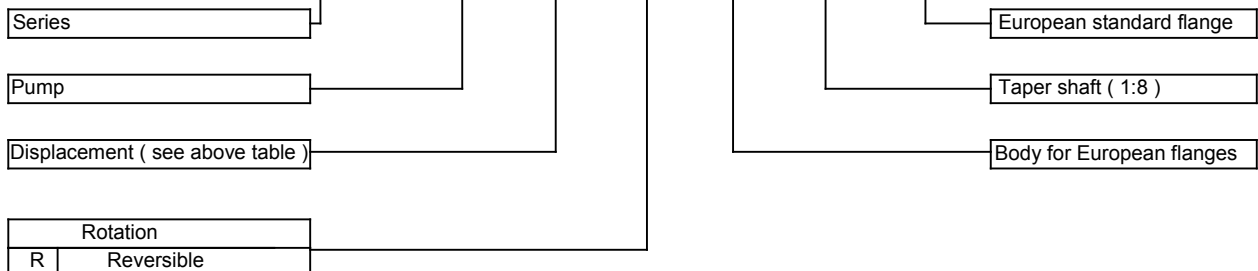

AVAILABLE FOR QUANTITIES

GROUP 1 REVERSIBLE PUMPS - EUROPEAN STANDARD

VERSION: G18 P1

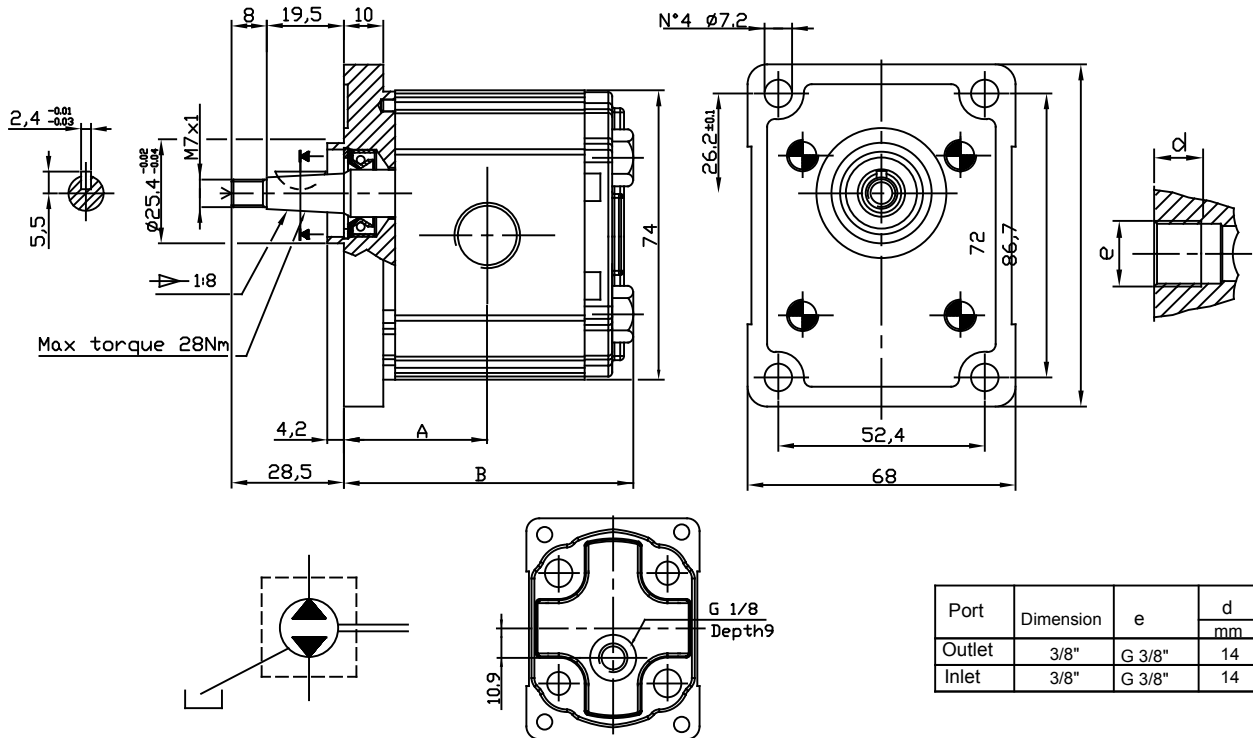

Type	Displacement (cc/rev)	Max working pressure P1 (bar)	Peak pressure P3 (bar)	Max speed (r.p.m)	Dimension B		Absorbed torque at 150 bar (Nm)	Code
					A	B		
OT 100 P16	1.45	180	230	5000	32.75	67.3	4.2	PS1007063R
OT 100 P20	1.80	210	250	5000	33.45	68.7	5.2	PS1007064R
OT 100 P25	2.45	210	250	5000	34.50	70.8	6.7	PS1007065R
OT 100 P32	3.05	210	250	5000	35.50	72.8	8.3	PS1007066R
OT 100 P40	3.80	210	250	4500	36.90	75.6	10.1	PS1007067R
OT 100 P49	4.70	200	240	4500	38.45	78.7	12.7	PS1007068R
OT 100 P58	5.55	200	220	4000	40.00	81.8	15.0	PS1007069R
OT 100 P65	6.25	180	210	3750	41.25	84.3	16.8	PS1007070R
OT 100 P79	7.60	160	200	3500	43.60	89.0	20.5	PS1017071R

EXAMPLE OF ORDERING CODE

OT100 P 20 R / G 18 P1

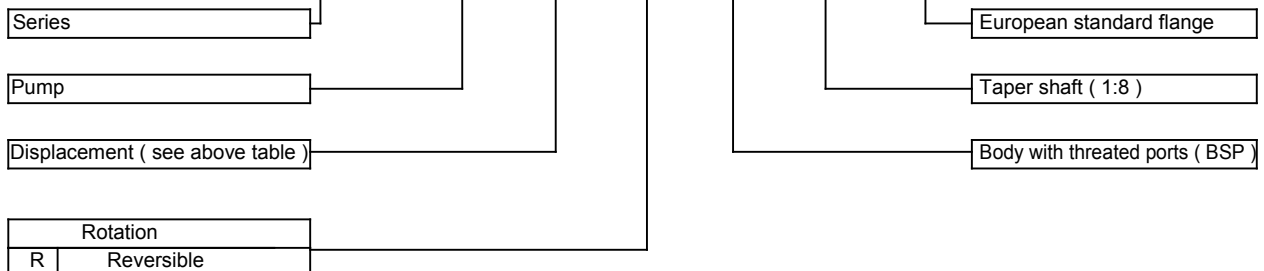

AVAILABLE FOR QUANTITIES

GROUP 1 PUMPS - WITH MAIN RELIEF VALVE

VERSION: G14 B0-VM

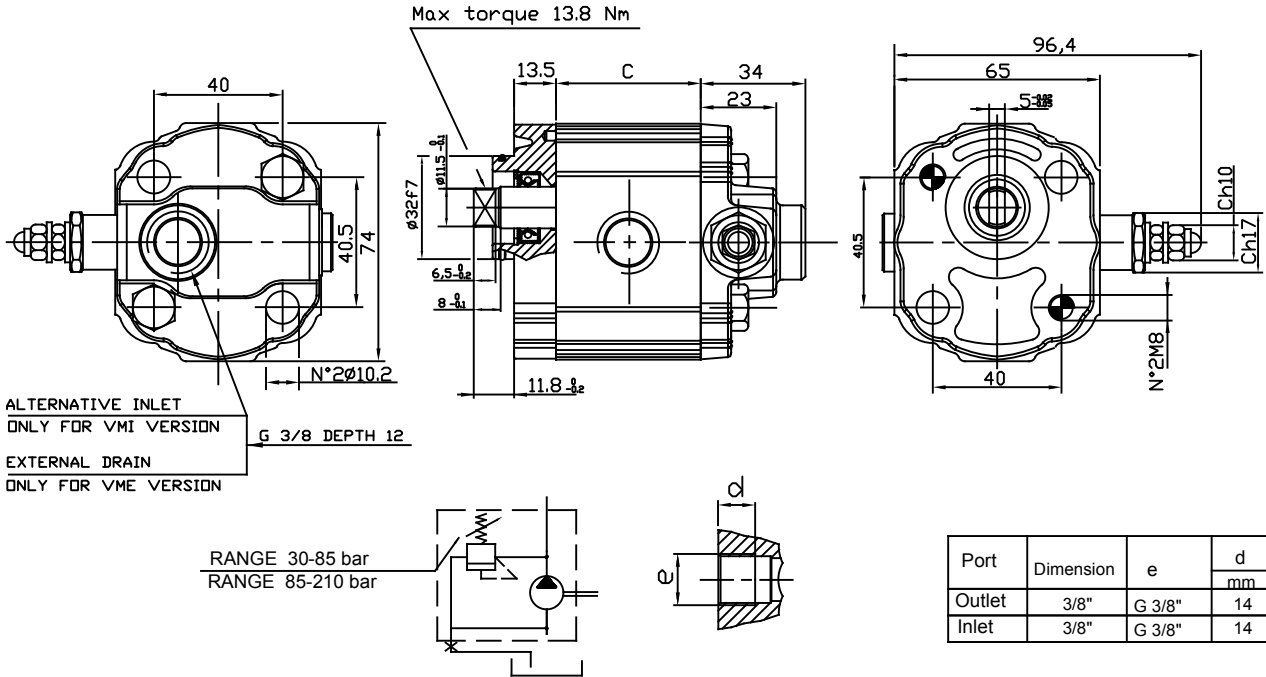

Type	Displacement (cc/rev)	Max speed (r.p.m)	Dimension B (mm)	Absorbed torque at 150 bar (Nm)
OT 100 P07	0.73	5000	36.7	1.8
OT 100 P11	1.05	5000	37.8	2.4
OT 100 P16	1.45	5000	39.5	4.2
OT 100 P20	1.80	5000	40.9	5.2
OT 100 P26	2.45	5000	43.0	6.7
OT 100 P32	3.05	5000	45.0	8.3
OT 100 P40	3.80	4500	47.8	10.1
OT 100 P49	4.70	4500	50.9	12.7
OT 100 P58	5.55	4000	54.0	15.0
OT 100 P65	6.25	3750	56.5	16.8
OT 100 P79	7.60	3500	61.2	20.5

AVAILABLE VERSIONS :

- 1) Lateral or alternative posterior inlet with internal drain.
- 2) Lateral inlet with external drain.

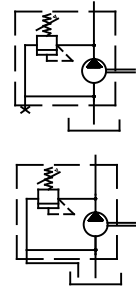

ESEMPIO DI CODICE D'ORDINAZIONE

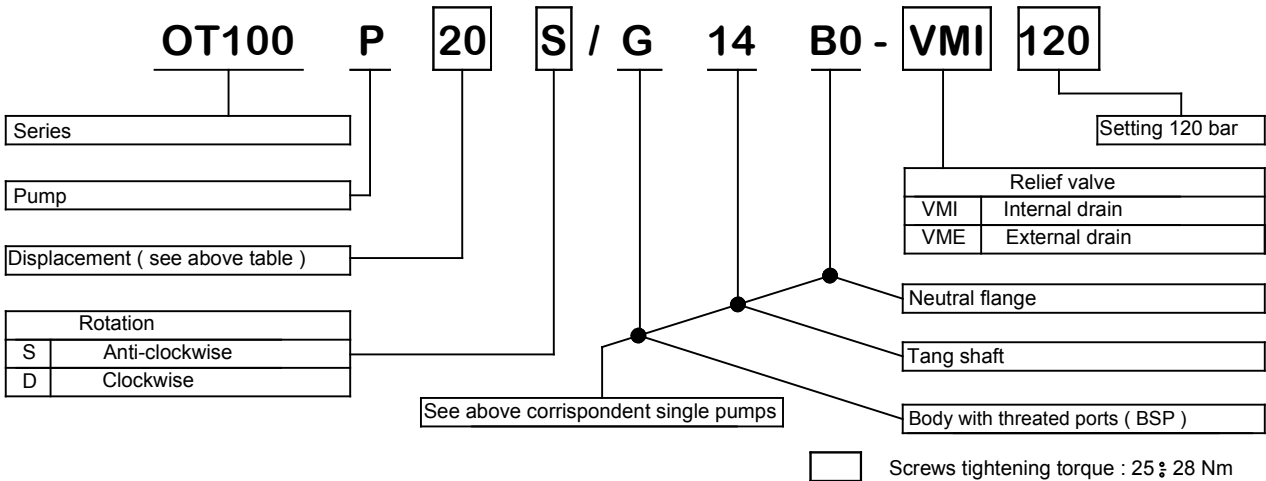

GROUP 1 PUMPS - WITH MAIN RELIEF VALVE

VERSION: B18 P1-VM

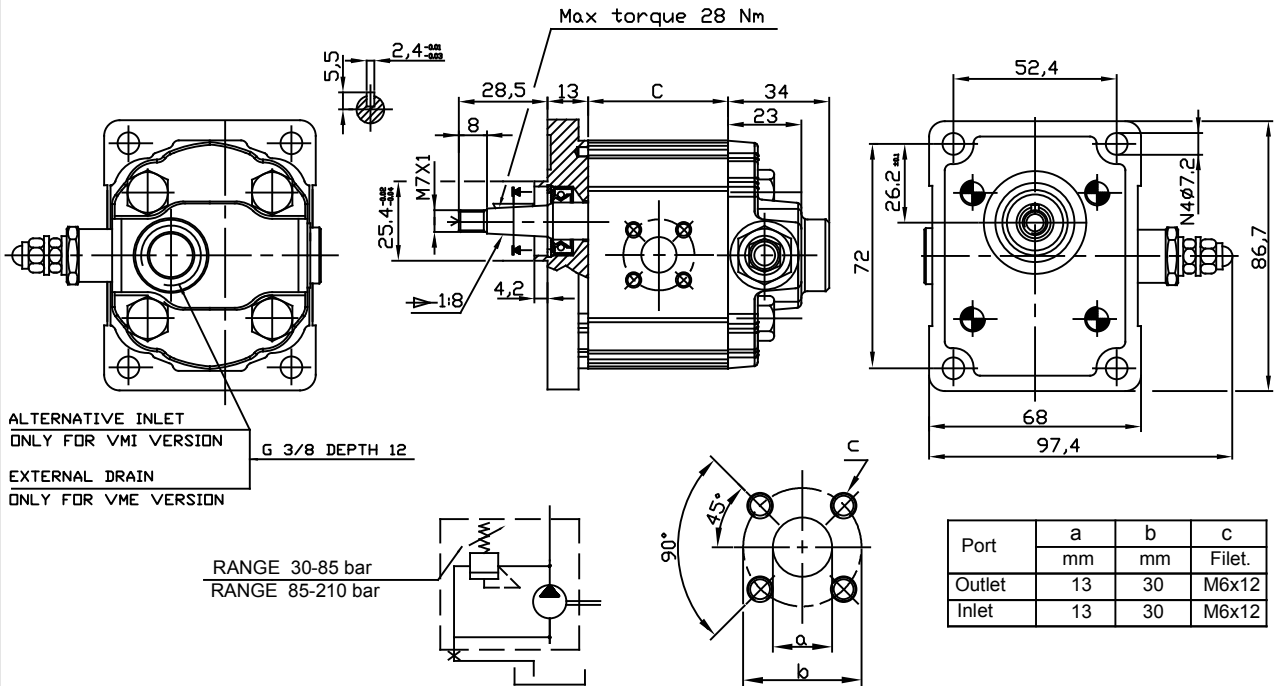

Type	Displacement (cc/rev)	Max speed (r.p.m)	Dimension B (mm)	Absorbed torque at 150 bar (Nm)
OT 100 P07	0.73	5000	36.7	1.8
OT 100 P11	1.05	5000	37.8	2.4
OT 100 P16	1.45	5000	39.5	4.2
OT 100 P20	1.80	5000	40.9	5.2
OT 100 P26	2.45	5000	43.0	6.7
OT 100 P32	3.05	5000	45.0	8.3
OT 100 P40	3.80	4500	47.8	10.1
OT 100 P49	4.70	4500	50.9	12.7
OT 100 P58	5.55	4000	54.0	15.0
OT 100 P65	6.25	3750	56.5	16.8
OT 100 P79	7.60	3500	61.2	20.5

AVAILABLE VERSIONS :

- 1) Lateral or alternative posterior inlet with internal drain.
- 2) Lateral inlet with external drain.

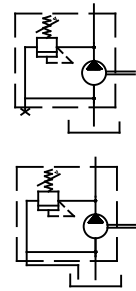

EXAMPLE OF ORDERING CODE

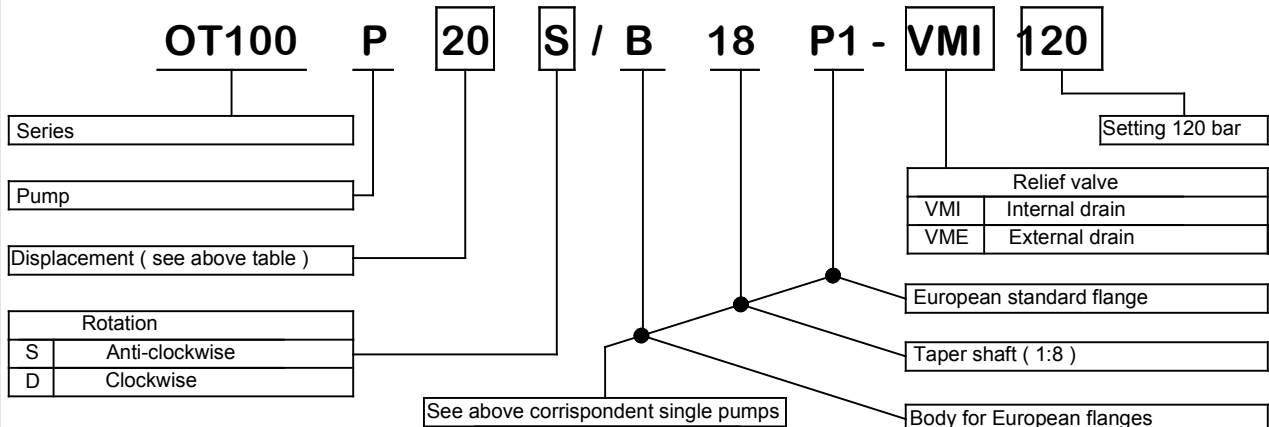

GROUP 1 PUMPS - TANDEM PUMPS

VERSION: G18 P1

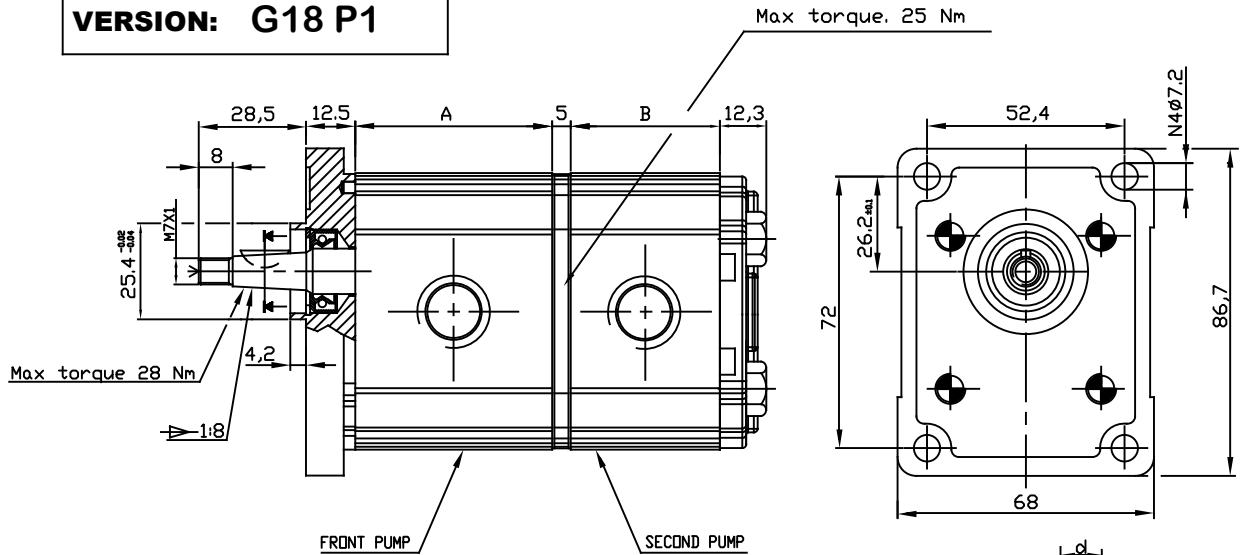

NOTE: The biggest displacement pump must be in the front position

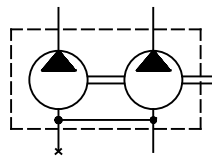

Port	Dimension	e	d
Outlet	3/8"	G 3/8"	14
Inlet	3/8"	G 3/8"	14

Type	Displacement (cc/rev)	Max working pressure P1 (bar)	Peak pressure P3 (bar)	Max speed (r.p.m)	Dimension		Absorbed torque at 150 bar (Nm)
					A	B	
OT 100 P07	0.73	200	240	4000	36.7	36.7	1.8
OT 100 P11	1.05	240	280	4000	37.8	37.8	2.4
OT 100 P16	1.55	260	300	4000	39.5	39.5	4.2
OT 100 P20	1.90	260	300	4000	40.9	40.9	5.2
OT 100 P26	2.50	260	300	4000	43.0	43.0	6.7
OT 100 P32	3.10	260	300	4000	45.0	45.0	8.3
OT 100 P40	3.80	260	300	3500	47.8	47.8	10.1
OT 100 P49	4.70	240	280	3500	50.9	50.9	12.7
OT 100 P58	5.55	200	240	3000	54.0	54.0	15.0
OT 100 P65	6.25	190	230	2750	56.5	56.5	16.8
OT 100 P79	7.60	170	220	2500	61.2	61.2	20.5

EXAMPLE OF ORDERING CODE

OT100 P 40 / 20 S / G 18 P1 / 2

Series	OT100
Pump	P
Front pump displacement (see above table)	40
Second pump displacement (see above table)	20
Rotation	S
	D

1 = One inlet port
2 = Two inlet ports

European standard flange

Taper shaft (1:8)

Body with threaded ports
(BSP)



AVAILABLE FOR QUANTITIES AS SECOND PUMP

GROUP 1 PUMPS - TANDEM PUMPS

VERSION: B18 P1

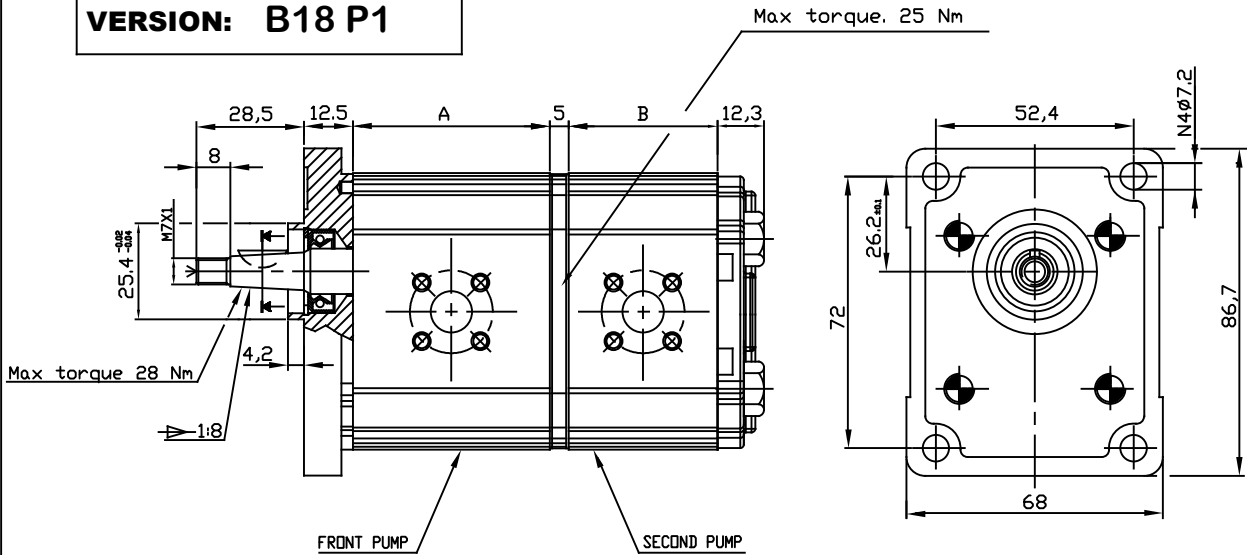

NOTE: The biggest displacement pump must be in the front position

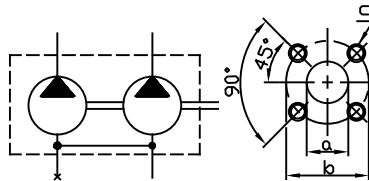

Port	a	b	c
	mm	mm	Tread
Outlet	13	30	M6x12
Inlet	13	30	M6x12

Type	Displacement (cc/rev)	Max working pressure P1 (bar)	Peak pressure P3 (bar)	Max speed (r.p.m)	Dimension		Absorbed torque at 150 bar (Nm)
					A	B	
(mm)							
OT 100 P07	0.73	200	240	4000	36.7	36.7	1.8
OT 100 P11	1.05	240	280	4000	37.8	37.8	2.4
OT 100 P16	1.55	260	300	4000	39.5	39.5	4.2
OT 100 P20	1.90	260	300	4000	40.9	40.9	5.2
OT 100 P26	2.50	260	300	4000	43.0	43.0	6.7
OT 100 P32	3.10	260	300	4000	45.0	45.0	8.3
OT 100 P40	3.80	260	300	3500	47.8	47.8	10.1
OT 100 P49	4.70	240	280	3500	50.9	50.9	12.7
OT 100 P58	5.55	200	240	3000	54.0	54.0	15.0
OT 100 P65	6.25	190	230	2750	56.5	56.5	16.8
OT 100 P79	7.60	170	220	2500	61.2	61.2	20.5

EXAMPLE OF ORDERING CODE

OT100 P 40 / 20 S / B 18 P1 / 2

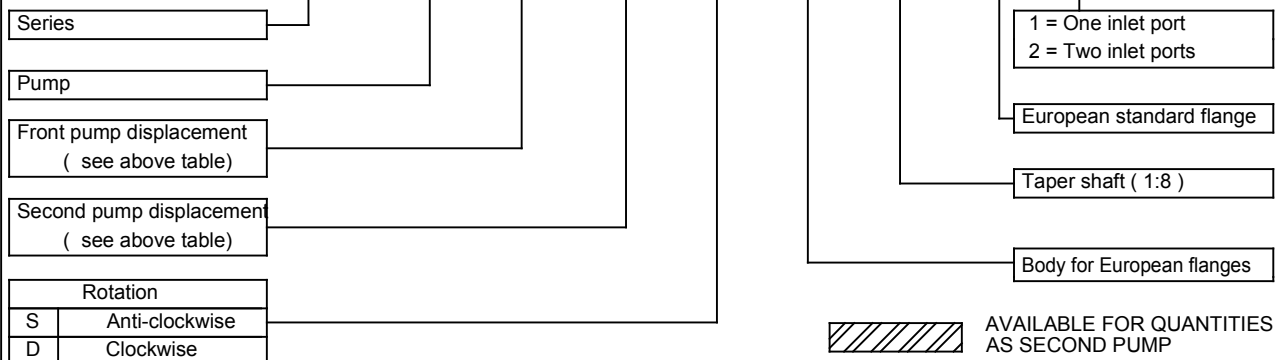

GROUP 1 PUMPS - TANDEM WITH SEQUENCE VALVE HI-LOW

VERSION: G18 P1-SV

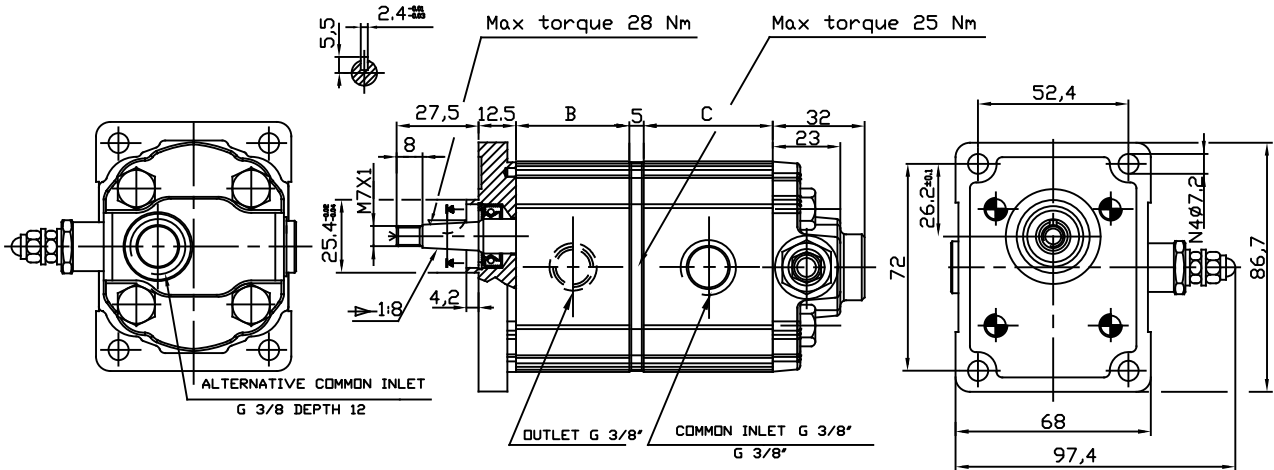

FRONT PUMP

TIPO	P1	P3	B	Cy
DT 100 P11	240	280	37.8	1.05
DT 100 P16	260	300	39.5	1.45
DT 100 P20	260	300	40.9	1.80
DT 100 P26	260	300	43	2.45
DT 100 P32	260	300	40.9	3.05
DT 100 P40	260	300	43	3.80

SECOND PUMP

TIPO	P1	C	Cy
DT 100 P26	15/65	43	2.4
DT 100 P40	15/65	47.8	3.8
DT 100 P49	15/65	50.9	4.6
DT 100 P65	15/65	50.9	6.2

P1 = working pressure (bar)
P3 = peak pressure (bar)
Cy = displacement (cc/rev)

RANGE 15/25 bar (blue spring)
RANGE 25/65 bar (red spring)

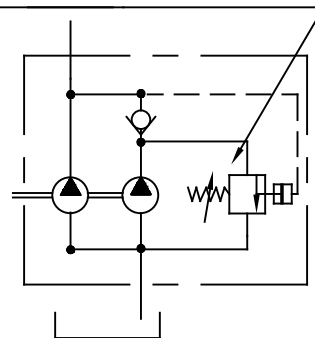

EXAMPLE OF ORDERING CODE

OT100 P 11 / 49 S / G 18 P1 - SV 30

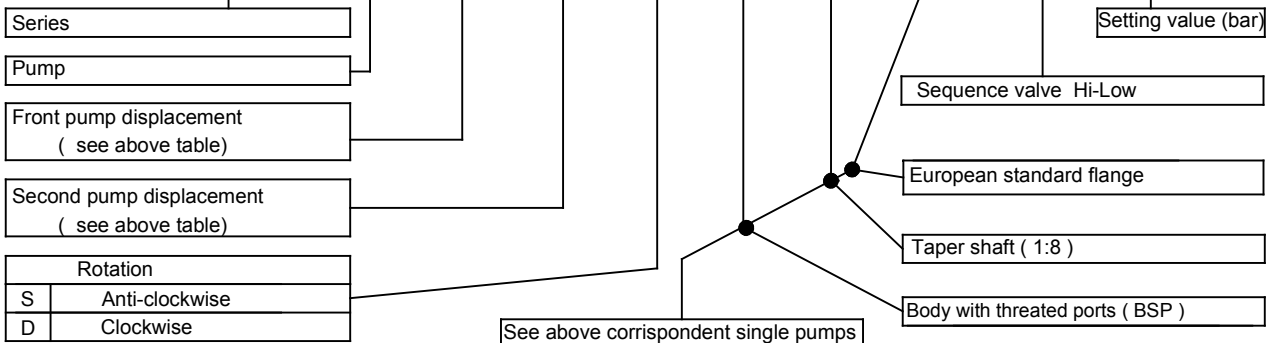

GROUP 1 PUMPS - TANDEM WITH SEQUENCE VALVE HI-LOW

VERSION: N14 B1-SV

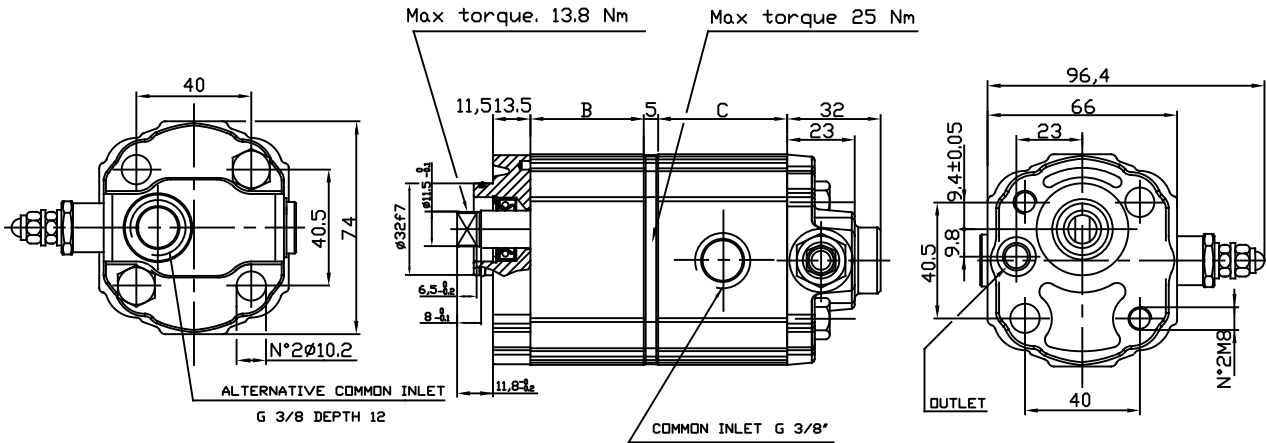

FRONT PUMP				
TIPO	P1	P3	B	Cy
DT 100 P11	240	280	37.8	1.05
DT 100 P16	260	300	39.5	1.45
DT 100 P20	260	300	40.9	1.80
DT 100 P26	260	300	43	2.45
DT 100 P32	260	300	40.9	3.05
DT 100 P40	260	300	43	3.80

SECOND PUMP			
TIPO	P1	C	Cy
DT 100 P26	15/65	43	2.4
DT 100 P40	15/65	47.8	3.8
DT 100 P49	15/65	50.9	4.6
DT 100 P65	15/65	50.9	6.2

P1 = work pressure (bar)
P3 = peak pressure (bar)
Cy = displacement (cc/rev)

RANGE 15/25 bar (blue spring)
RANGE 25/65 bar (red spring)

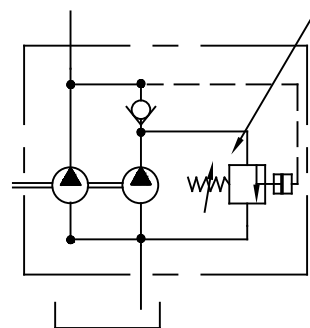

EXAMPLE OF ORDERING CODE

OT100 P 11 / 49 S / N 14 B1 - SV 30

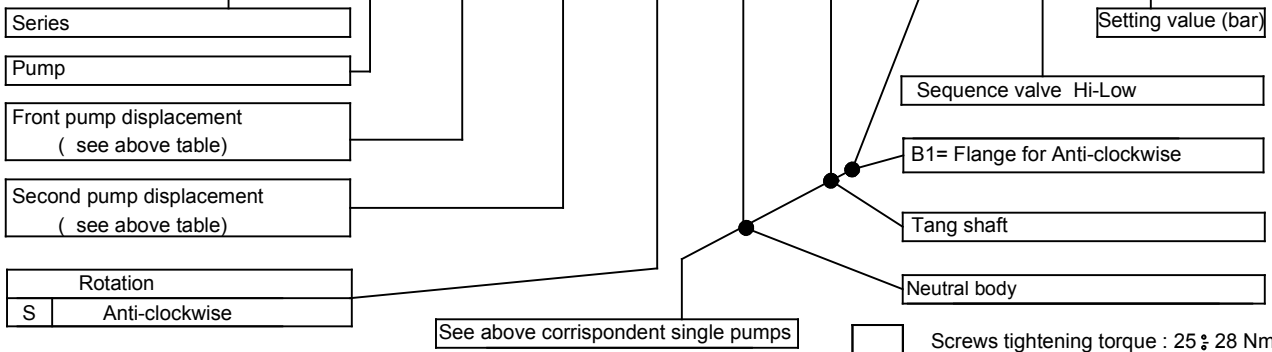

GROUP 1 PUMPS - WITH SEQUENCE VALVE HI-LOW

VERSION: N14 B2-VS

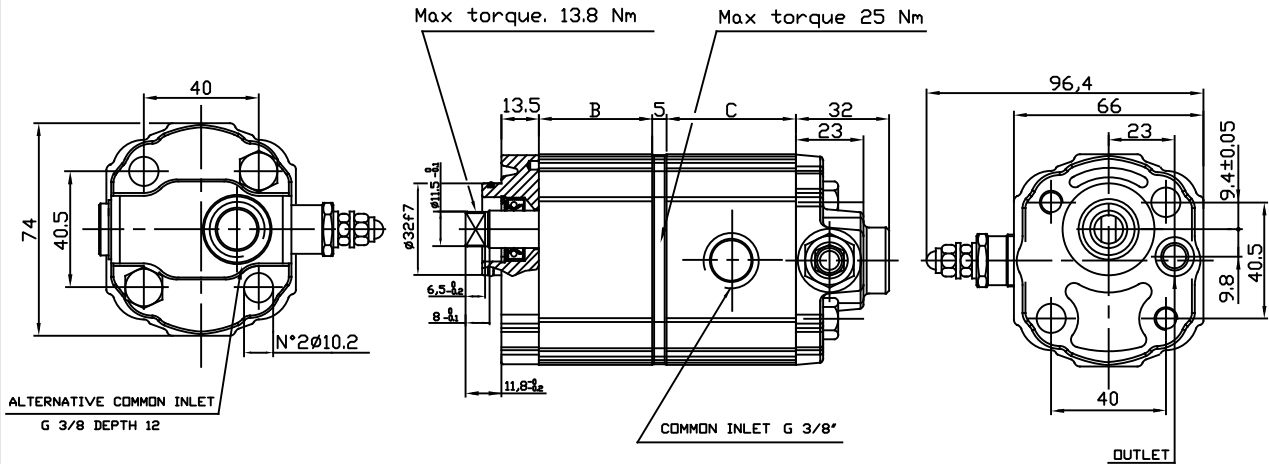

FRONT PUMP

TIPO	P1	P3	B	Cy
DT 100 P11	240	280	37.8	1.05
DT 100 P16	260	300	39.5	1.45
DT 100 P20	260	300	40.9	1.80
DT 100 P26	260	300	43	2.45
DT 100 P32	260	300	40.9	3.05
DT 100 P40	260	300	43	3.80

SECOND PUMP

TIPO	P1	C	Cy
DT 100 P26	15/55	43	2.4
DT 100 P40	15/55	47.8	3.8
DT 100 P49	15/55	50.9	4.6
DT 100 P65	15/55	50.9	6.2

P1 = work pressure (bar)
P3 = peak pressure (bar)
Cy = displacement (cc/rev)

RANGE 15/25 bar (blue spring)
RANGE 25/65 bar (red spring)

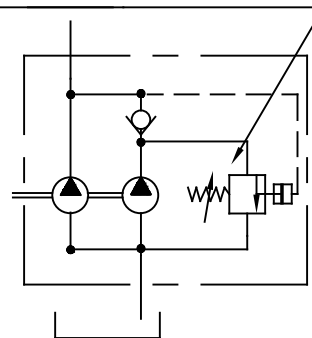

EXAMPLE OF ORDERING CODE

OT100 P 11 / 49 D / N 14 B2 - SV 30

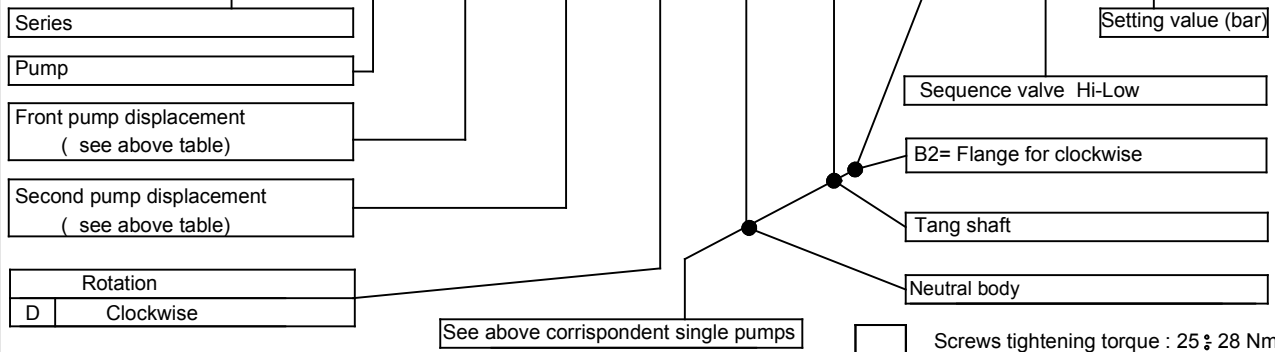



GROUP 1 MOTORS

OT100 SINGLE ROTATION MOTORS GENERAL DATA

MOTOR TYPE	DISPLACEMENT	MAX. PRESSURE			MAX. SPEED	MIN. SPEED
		P1	P2	P3		
	cc / rev	bar			rev	rev
OT100 M16	1.45	250	280	300	5000	600
OT100 M20	1.80					
OT100 M25	2.45					
OT100 M32	3.05					
OT100 M40	3.80					
OT100 M49	4.70	200	220	240	4500	500
OT100 M58	5.55	200	210	230		
OT100 M65	6.25	170	190	220	3500	
OT100 M79	7.60					

P1= Max. continuous pressure

P2= Max. intermittent pressure

P3= Max. peak pressure

**FOR DIMENSION PLEASE CHECK
RELATIVE SINGLE PUMP TABLES**



GROUP 1 MOTORS

FLOW CHARACTERISTICS CURVES

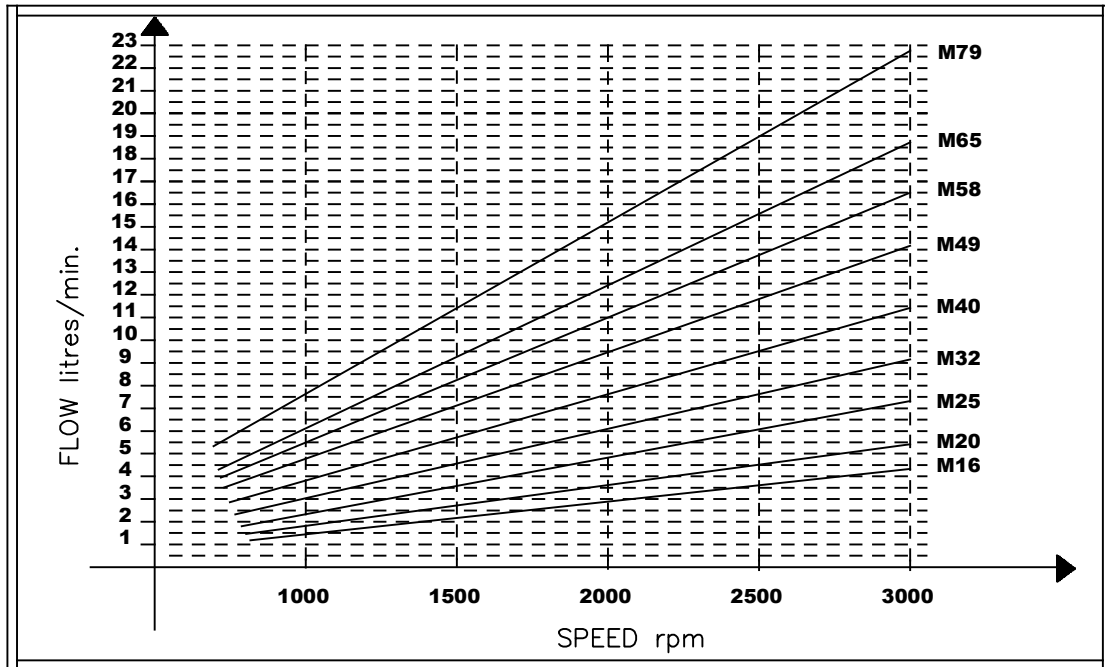

ABSORBED TORQUE

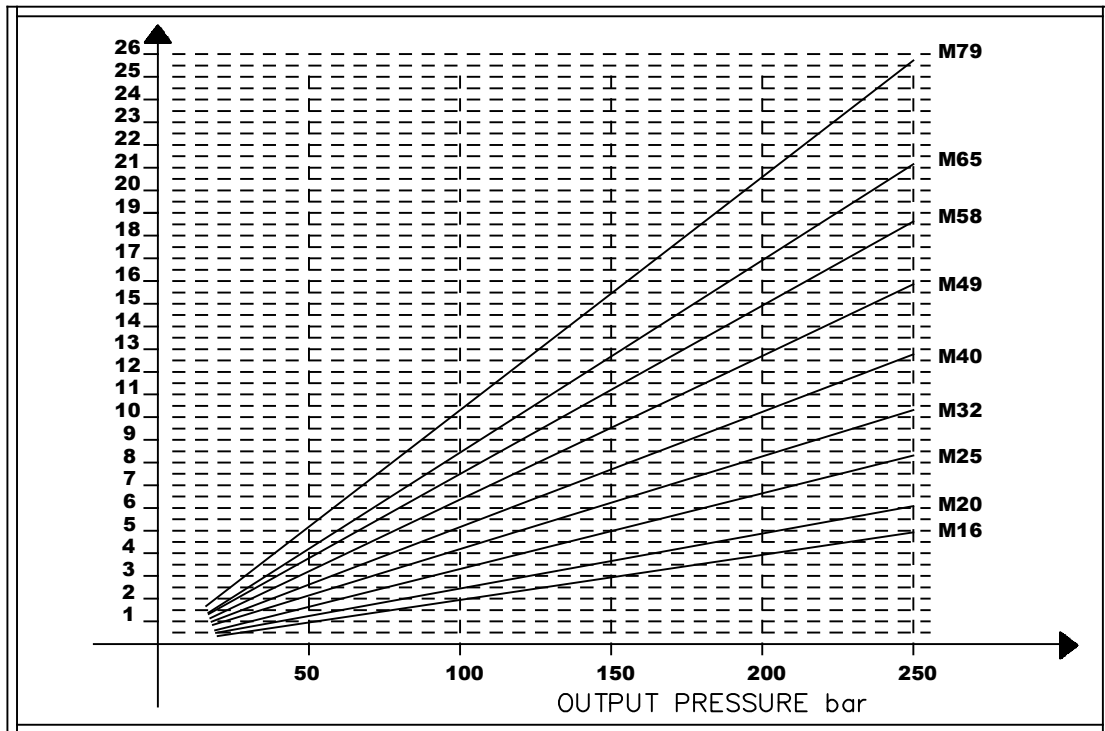

NOTE

The flow characteristics curves have been made at P1 pressure.

**GROUP 1 MOTORS****MOTOR CALCULATION**

V	Displacement	cc/rev
Q	Flow	l/min
P	Power	kW
C	Torque	N · m
N	Speed	rpm
ΔP	Pressure	bar
n_v	Volumetric efficiency	0.95
n_m	Mechanical efficiency	0.85
n_t	Total efficiency	0.81

$$Q = \frac{V \cdot N}{n_v} \cdot 10^{-3} \quad \text{l/min}$$

$$C = \frac{\Delta P \cdot V_m \cdot n}{62.8} \quad \text{N} \cdot \text{m}$$

$$P = \frac{\Delta P \cdot V \cdot N}{612000} \cdot n \quad \text{kW}$$



GROUP 1 MOTORS - TORQUE CHARACTERISTICS CURVES

MOTORS OT100 M16

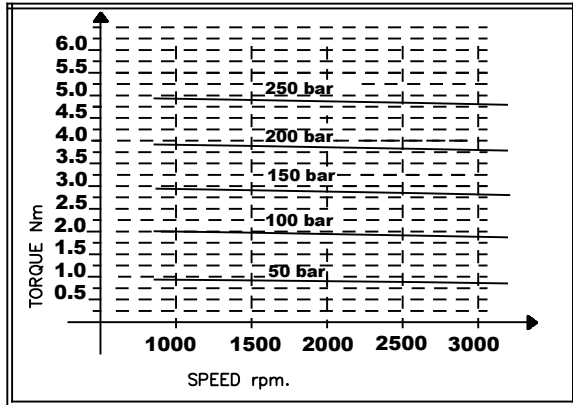

MOTORS OT100 M20

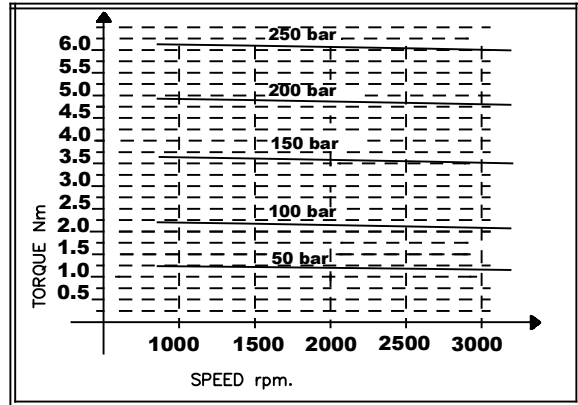

MOTORS OT100 M25

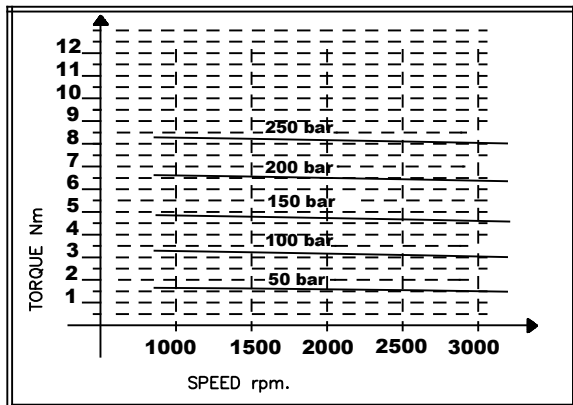

MOTORS OT100 M32

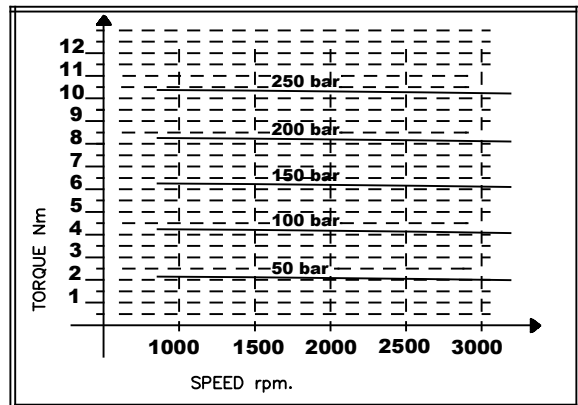

MOTORS OT100 M40

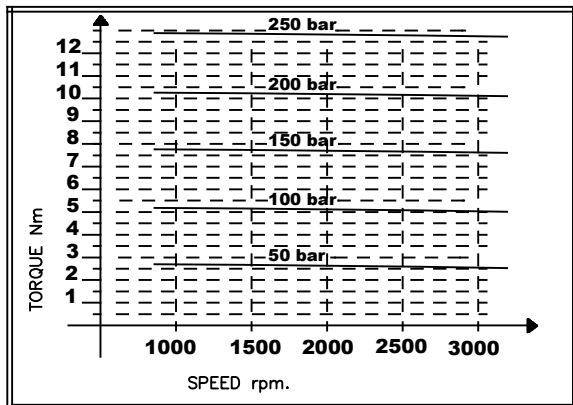

MOTORS OT100 M49

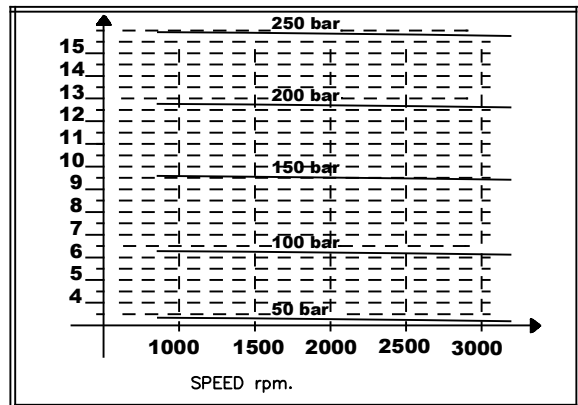



GROUP 1 MOTORS - TORQUE CHARACTERISTICS CURVES

MOTORS OT100 M58

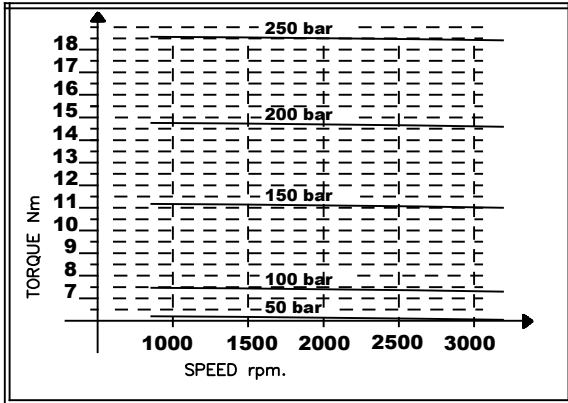

MOTORS OT100 M65

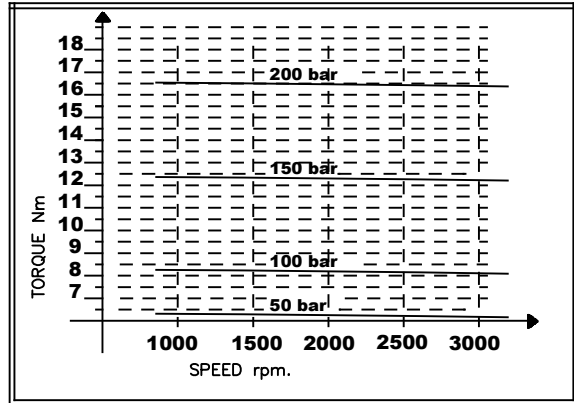

MOTORS OT100 M79

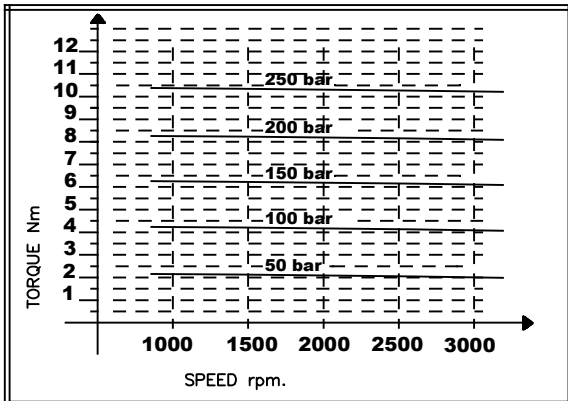

GROUP 1 REVERSIBLE MOTORS - EUROPEAN STANDARD

VERSION: B18 P1

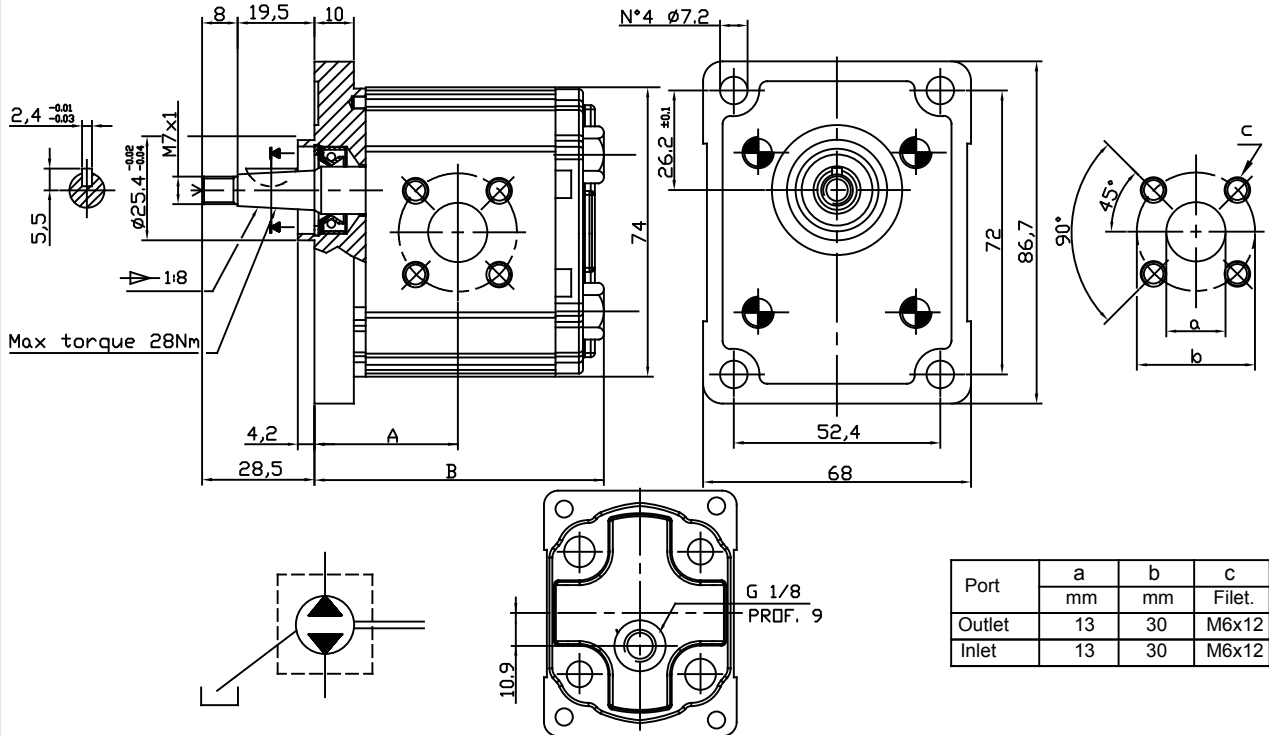

Port	a mm	b mm	c Filet.
Outlet	13	30	M6x12
Inlet	13	30	M6x12

Displacement

Type	(cc/rev)	Max working pressure P1 (bar)	Peak pressure P3 (bar)	Max speed (r.p.m)	Dimension (mm)		Absorbed torque at 150 bar (Nm)	Code
					A	B		
OT 100 M16	1.45	180	230	5000	32.75	67.3	4.2	PS1009083R
OT 100 M20	1.80	210	250	5000	33.45	68.7	5.2	PS1009084R
OT 100 M25	2.45	210	250	5000	34.50	70.8	6.7	PS1009085R
OT 100 M32	3.05	210	250	5000	35.50	72.8	8.3	PS1009086R
OT 100 M40	3.80	210	250	4500	36.90	75.6	10.1	PS1009087R
OT 100 M49	4.70	200	240	4500	38.45	78.7	12.7	PS1009088R
OT 100 M58	5.55	200	220	4000	40.00	81.8	15.0	PS1009089R
OT 100 M65	6.25	180	210	3750	41.25	84.3	16.8	PS1009090R
OT 100 M79	7.60	160	200	3500	43.60	89.0	20.5	PS1019091R

EXAMPLE OF ORDERING CODE

OT100 M 20 R / B 18 P1

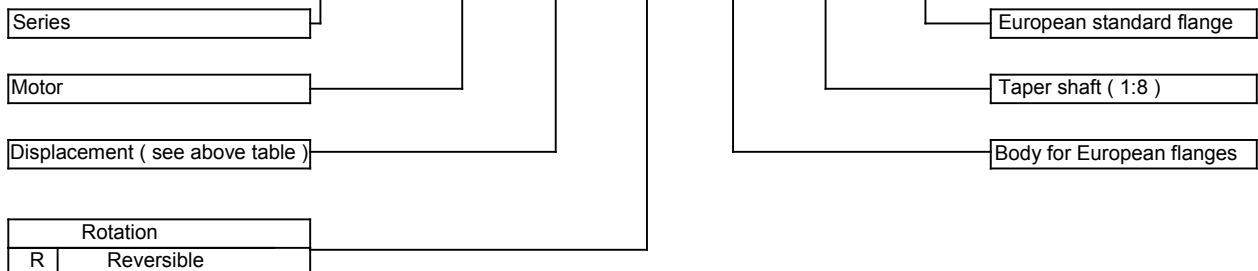

GROUP 1 REVERSIBLE MOTORS - EUROPEAN STANDARD

VERSION: G18 P1

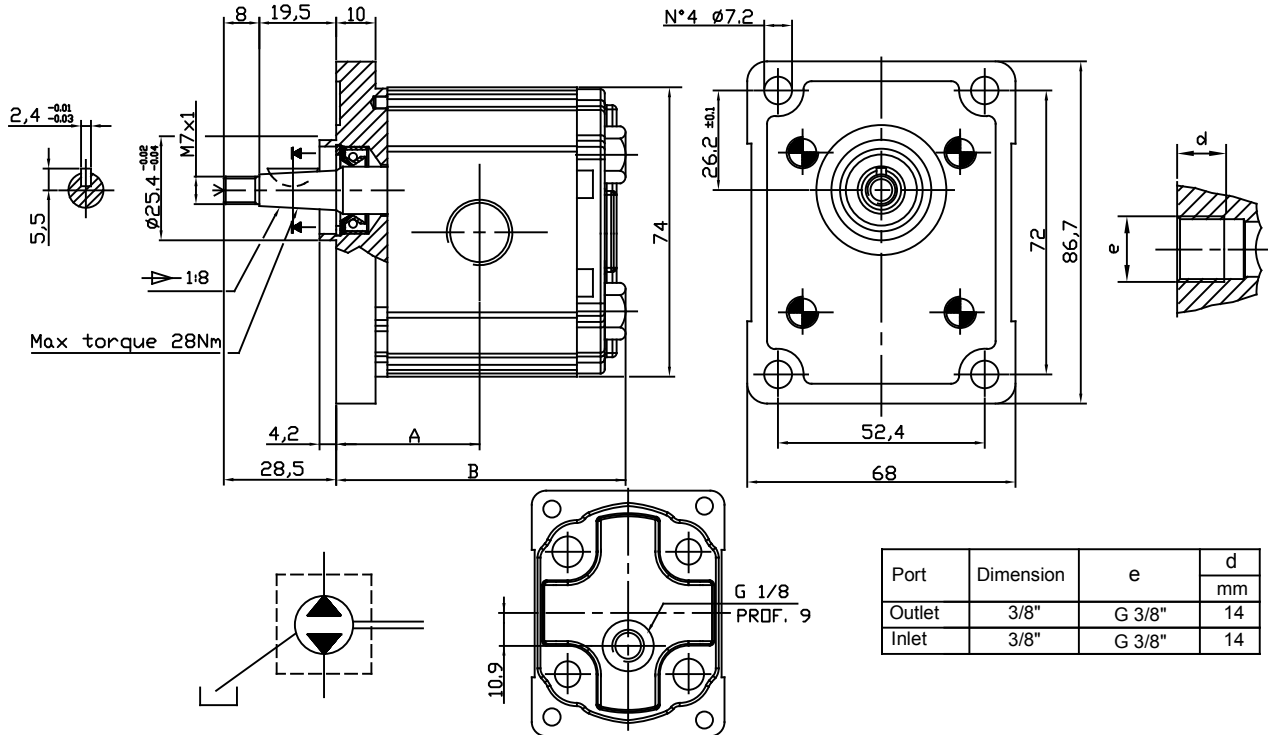

Port	Dimension	e	d
Outlet	3/8"	G 3/8"	14
Inlet	3/8"	G 3/8"	14

Type	Displacement (cc/rev)	Max working pressure P1 (bar)	Peak pressure P3 (bar)	Max speed (r.p.m)	Dimension B		Absorbed torque at 150 bar (Nm)	Code
					A	B		
OT 100 M16	1.45	180	230	5000	32.75	67.3	4.2	PS1009063R
OT 100 M20	1.80	210	250	5000	33.45	68.7	5.2	PS1009064R
OT 100 M25	2.45	210	250	5000	34.50	70.8	6.7	PS1009065R
OT 100 M32	3.05	210	250	5000	35.50	72.8	8.3	PS1009066R
OT 100 M40	3.80	210	250	4500	36.90	75.6	10.1	PS1009067R
OT 100 M49	4.70	200	240	4500	38.45	78.7	12.7	PS1009068R
OT 100 M58	5.55	200	220	4000	40.00	81.8	15.0	PS1009069R
OT 100 M65	6.25	180	210	3750	41.25	84.3	16.8	PS1009070R
OT 100 M79	7.60	160	200	3500	43.60	89.0	20.5	PS1019071R

EXAMPLE OF ORDERING CODE

OT100 M 20 R / G 18 P1

Series

Pump

Displacement (see above table)

Rotation

R Reversible

European standard flange

Taper shaft (1 : 8)

Body with threaded ports (BSP)

GROUP 1 PUMPS - SPECIAL VERSION FOR POWER UNITS

VERSION: N18 B1

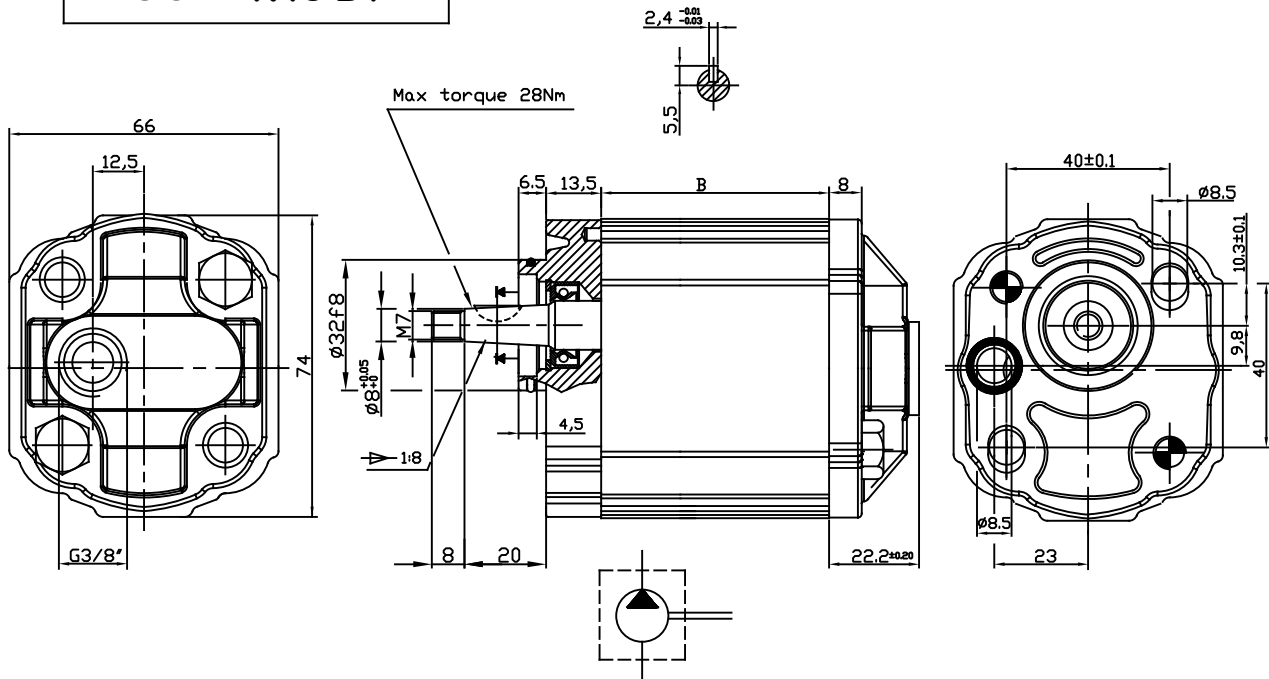

Type	Displacement (cc/ rev)	Max working pressure P1 (bar)	Peak pressure P3 (bar)	Max speed (rpm)	Dimension B (mm)	Absorbed torque at 150 bar (Nm)	Code (Anti- Clockwise)
OT 100 P11	1.05	240	280	5000	37.8	2.4	PS1007302S
OT 100 P16	1.45	260	300	5000	39.5	4.2	PS1007303S
OT 100 P20	1.80	240	300	5000	40.9	5.2	PS1007304S
OT 100 P26	2.45	240	280	5000	43.0	6.7	PS1007305S
OT 100 P32	3.05	240	280	5000	45.0	8.3	PS1007306S
OT 100 P40	3.80	220	260	4500	47.8	10.1	PS1007307S
OT 100 P49	4.70	200	240	4500	50.9	12.7	PS1007308S
OT 100 P58	5.55	180	220	4000	54.0	15.0	PS1007309S
OT 100 P65	6.25	160	200	3750	56.5	16.8	PS1007310S
OT 100 P79	7.60	140	180	3500	61.2	20.5	PS1017301S

EXAMPLE OF ORDERING CODE

OT100 P 20 S / N 18 B1

Series

Pump

Displacement (see above table)

Rotation

S Anti-clockwise

B1= Flange for Anti-clockwise

Taper shaft (1:8)

Body without ports

□ Screws tightening torque : 25 ± 28 Nm

GROUP 1 PUMPS - SPECIAL VERSION FOR POWER UNITS

VERSION: N18 B2

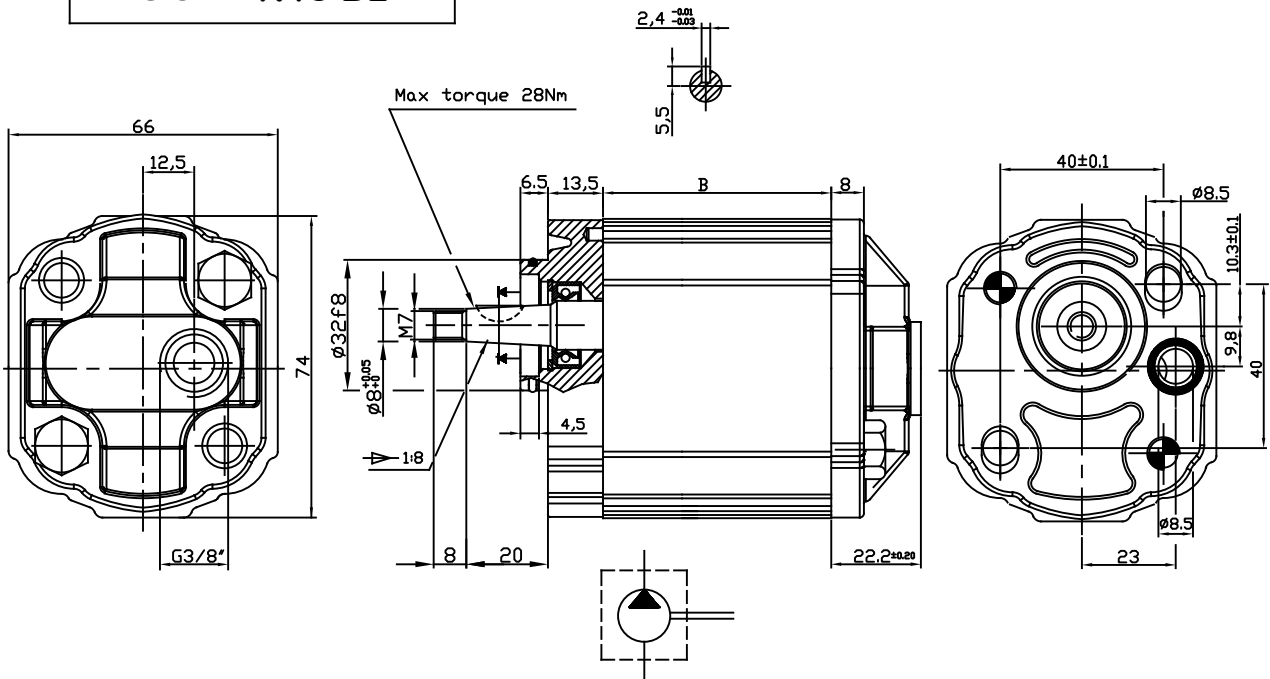

Type	Displacement (cc/rev)	Max working pressure P1 (bar)	Peak pressure P3 (bar)	Max speed (rpm)	Dimension B (mm)	Absorbed torque at 150 bar (Nm)	Code (Anti-Clockwise)
OT 100 P11	1.05	240	280	5000	37.8	2.4	PS1007302D
OT 100 P16	1.45	260	300	5000	39.5	4.2	PS1007303D
OT 100 P20	1.80	240	300	5000	40.9	5.2	PS1007304D
OT 100 P26	2.45	240	280	5000	43.0	6.7	PS1007305D
OT 100 P32	3.05	240	280	5000	45.0	8.3	PS1007306D
OT 100 P40	3.80	220	260	4500	47.8	10.1	PS1007307D
OT 100 P49	4.70	200	240	4500	50.9	12.7	PS1007308D
OT 100 P58	5.55	180	220	4000	54.0	15.0	PS1007309D
OT 100 P65	6.25	160	200	3750	56.5	16.8	PS1007310D
OT 100 P79	7.60	140	180	3500	61.2	20.5	PS1017301D

EXAMPLE OF ORDERING CODE

OT100 P 20 D / N 18 B2

Series

Pump

Displacement (see above table)

Rotation

D clockwise

B2= Flange for clockwise

Taper shaft (1:8)

Body without ports

Screws tightening torque : 25 ± 28 Nm



BREVINI[®]

Motion Systems

Dana Brevini S.p.A.

Via Luciano Brevini 1/a

42124 Reggio Emilia

Tel. +39 0522 270711

Fax +39 0522 270660

www.dana.com/brevini

info@brevinifluidpower.com



1800-OILSOL
1800-645765

<https://oilsolutions.com.au/>

sales@oilsolutions.com.au

Catalogue code: OT 100 TEC. E. 06.2018

Dana Incorporated

OT OilTechnology S.r.l.u.

Strada Romitaggio, 23

43010 Bianconese di Fontevivo (PR) Italy

Tel.: +39 0521 628761

Fax: +39 0521 667764

www.ot-oiltechnology.com

sales@ot-oiltechnology.com