

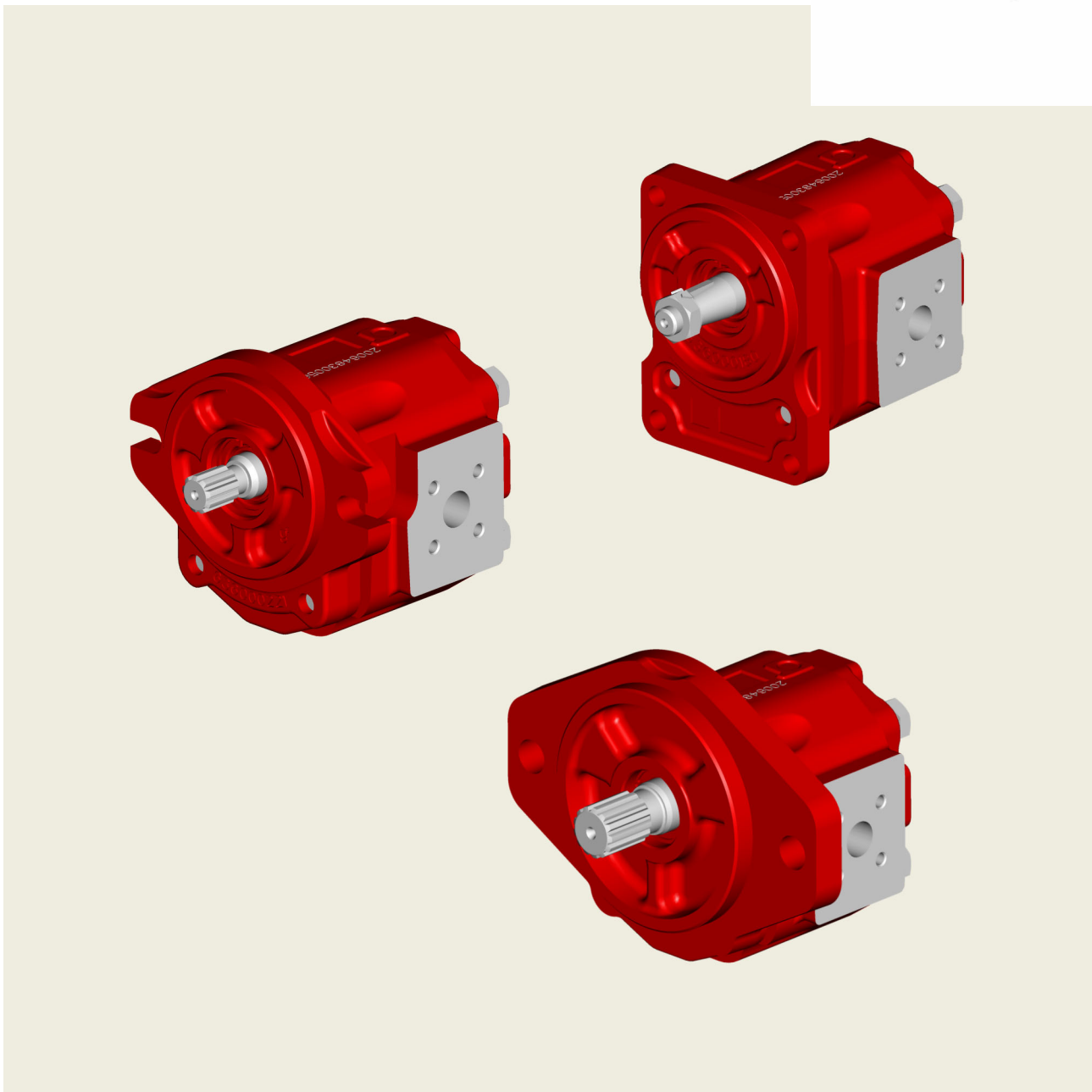

AP212HP Cast Iron Gear Pumps

Standard and Low Noise series



Contents

Page

1	General information	4
1.1	External gear pumps components	5
1.2	Technical data	6
1.3	Pressure	6
1.4	Suction	7
1.5	General precaution	7
1.6	Identifying the rotation direction	8
1.7	Motor-pump coupling	8
1.8	Non-standard symbols used in the text	9
1.9	Calculating the specification of a gear pump	9
1.10	Diagrams	10
2	Overview standard types	12
2.1	Standard configuration	12
3	AP212HP Single pump customised versions	29
3.1	Single pump customised versions order example	30
3.2	Single pump dimensions	31
3.3	Shaft end code	32
3.4	Front cover	33
3.5	Cast iron body	36
3.6	Back covers	39
4	Multiple gear pumps	42
4.1	Drive torque	42
4.2	Tandem pumps dimensions AP212HP+AP212HP (standard version without shaft seal between the pumps)	43
4.3	Tandem pumps dimensions AP212HP+AP212HP (standard version with shaft seal between the pumps)	44
4.4	Tandem pumps dimensions AP212HP+AP212 aluminium body (standard version without shaft seal between the pumps)	45
4.5	Tandem pumps dimensions AP212HP+AP212 aluminium body (standard version with shaft seal between the pumps)	47
4.6	How to order tandem pumps (with or without shaft seal between the pumps)	49
5	Circuits/valves option	50
5.1	Load sensing circuits	50

6	Rotation changing instructions	52
7	Pumps seal kit NBR + HNBR standard type	53
8	Product identification plate	54
9	Application form	55

1 General information

The product range of Bucher Hydraulics SpA includes single pumps 05-100-212-212HP-250HP-300-312HP (corresponding with the common group denominations: 05-1-2-2.5-3) and several combinations of double pumps, triple pumps, and so on, that can be assembled together according to

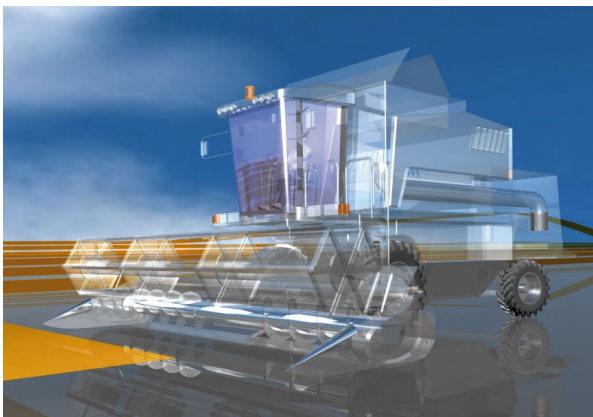

Bucher Hydraulics has so achieved these results by constantly improving its design, control and manufacturing techniques inline with the latest technological developments, while simultaneously enhancing our Quality

versions of displacement, flanging, and auxiliary valves. External gear pumps are widely used in modern hydraulic systems due to their high performance, long service life and low purchase and maintenance costs.

Here following we introduce you the new AP212HP family range.

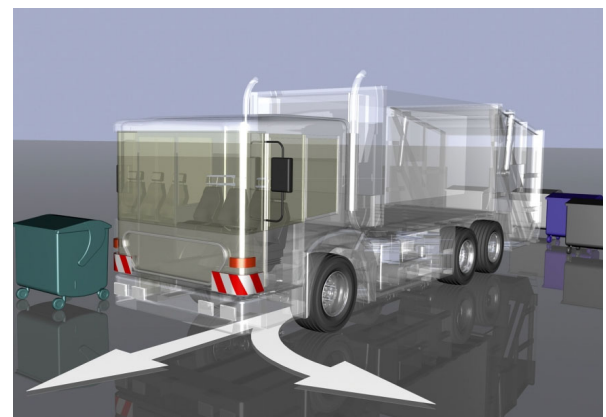

Control System which ensures that every single product offers the same high standards.

Maintaining all the basic AP212 project characteristics, the new AP212HP series is improving the reliability of the complete product, strongly increasing the mechanical resistance of the pump body.

This important feature, reached through the use of cast iron material and dedicated body shape, allows the life extension of the products improving working and maximum pressures, reaching very high performance limits.

With this reliability performances it is possible to replace traditional aluminium pumps in applications where high working pressure in combination with high number of insertions and long life are requested.

The new AP212HP series pump is completed with front and rear cast iron covers: the mechanical strength of this product also allows to reduce noise and vibrations.

Other internal components, such as balancing blocks and gears, are the same used in the AP212 series; this means that the new AP212HP (unidirectional and reversible) is available in standard and low noise version.

Due to their compatible interface, tandem or multiple pumps are manufacturable both with common or split inlet suction lines.

1.1 External gear pumps components

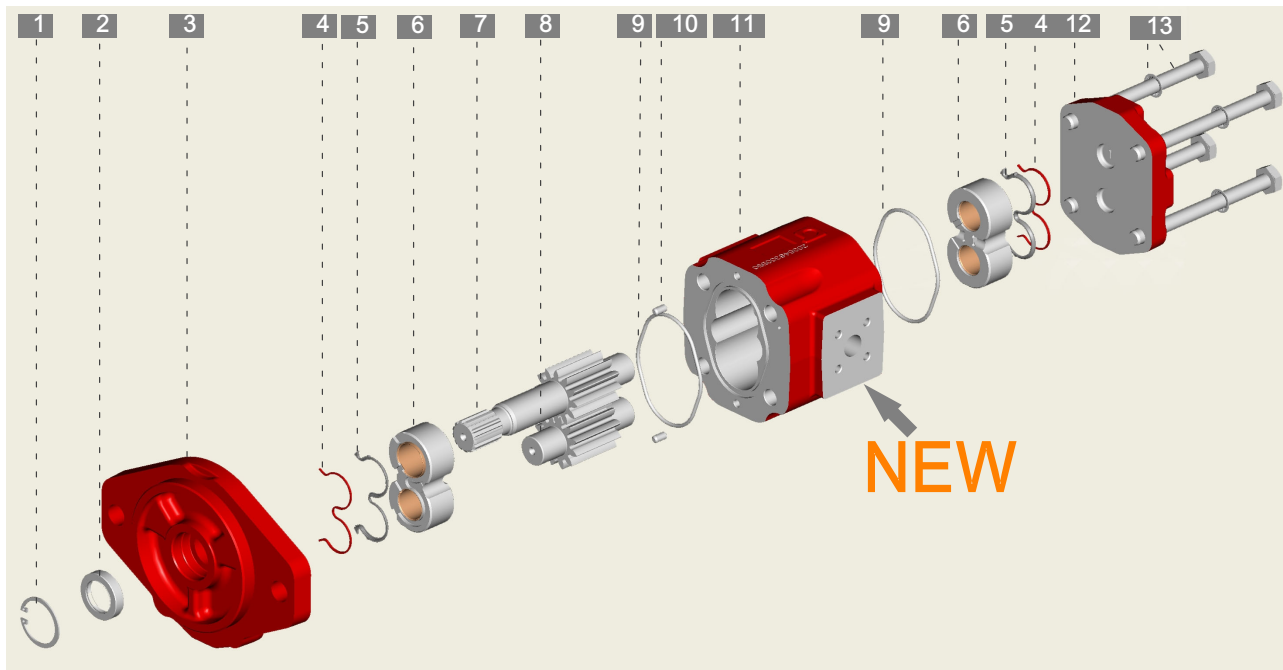

1. Retaining ring
2. Shaft seal
3. Front cover cast iron made
4. Balancing seals
5. Back up seals
6. Balancing blocks
7. Drive gear, standard or low noise type

8. Driven gear, standard or low noise type
9. Oil seal
10. Centering pins
11. Pump body, cast iron made
12. Back cover, cast iron made
13. Fixing screws and washers

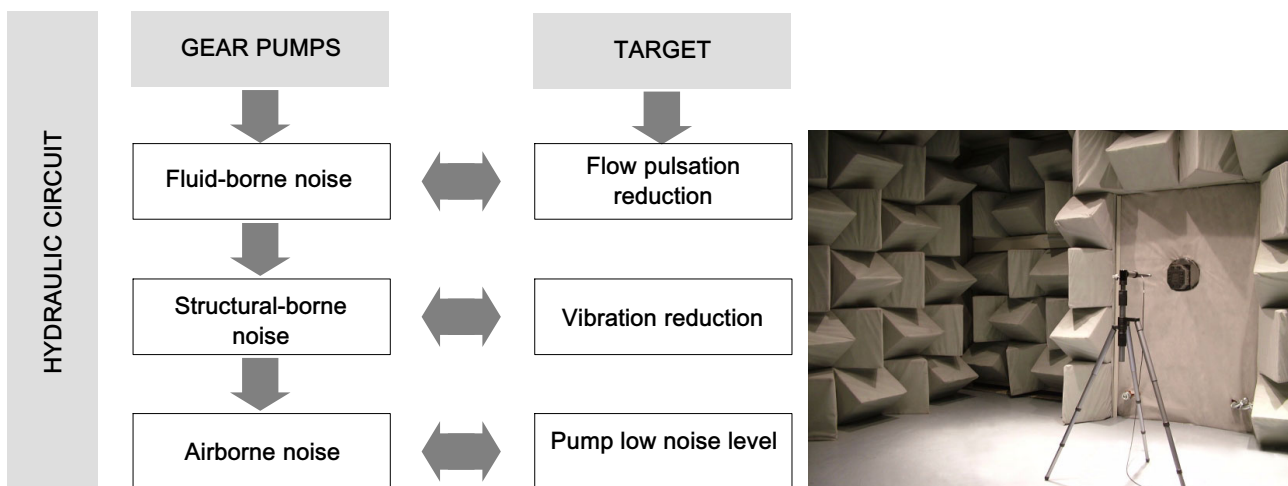

1.2 Technical data

Features	
Operating fluid temperature range (mineral oil):	NBR HNBR FPM (VITON)
Recommended fluids	hydraulic mineral oil-based
Viscosity range:	Recommended Permitted Permitted for starting
Cleanliness:	recommended for operating pressure > 170 bar recommended for operating pressure < 170 bar
Standard seals material (valves not included)	NBR + HNBR standard (ISO1629)

Type	AP212HP Displacement		AP212HPLN Displacement		Max. pressure**						n min. P2 < 100 bar rpm	n min. 100 < n < 180 bar rpm	n min. 180 < n < P2 rpm	n max. rpm
	cm ³ /rev	Cu.In. P.R.	cm ³ /rev	Cu.In. P.R.	P1 (continuous)		P2 (intermittent)		P3 (peak)					
					bar	psi	bar	psi	bar	psi				
15	15.1	.921	15.7	.958	250	3630	280	4060	300	4350	500	750	1000	3500
19	19.2	1.172	19.8	1.208	250	3630	280	4060	300	4350	500	750	1000	3500
22	22.2	1.355	23	1.404	250	3630	270	3920	300	4350	500	750	1000	3000
26	26.2	1.599	27.1	1.654	250	3630	260	3770	280	4060	500	750	1000	2800
29 (*)	28.9	1.764	29.9	1.825	220	3190	240	3480	250	3630	500	750	1000	2500
33 (*)	33	2.014	34.1	2.081	200	2900	220	3190	240	3480	500	750	1000	2400

(*) Displacements on request: please contact our Sales Department.
In case of use as tandem pump max pressure must be limited, please contact our Sales Center.

** Referred to pumps with flanged ports. Utilising threaded ports, please to consider a significantly de-rated performances.
The mechanical stress localised on threaded ports cause a reduced pump life performances.



IMPORTANT!: Please consult Bucher Hydraulics if even one of the operating limits indicated in the table (temperature, pressure, rpm) is exceeded, as well as in the case of two or more maximum values at the same time, or for applications with particularly heavy-duty cycles

1.3 Pressure

Pressure levels:

P1 = continuous pressure

P2 = intermittent pressure

P3 = peak pressure

The recommended oil speed in the pressure pipes is:

$v = 2$ to 5 m/s

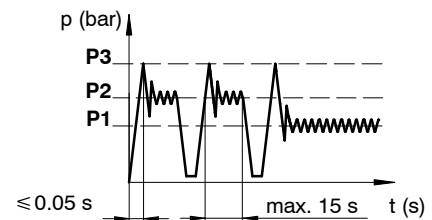

1.4 Suction

The absolute suction pressure must be $P_{in} \geq 0.75$ bar (11 PSI); therefore, the following conditions must be avoided:

- large height differences between pump and tank
- long stretches of piping
- special features such as:
 - bends
 - reductions in diameter
 - quick couplings
 - etc.

It is also advisable to choose a filter of a suitable size to minimise any pressure drop and to take measures to prevent gradual clogging over time.

(Example 1)

In certain cases, the suction pressure can exceed 1 bar (14.3 PSI), or atmospheric pressure.

Please contact our Sales Department, solution for

$P_{in} \leq 3.5$ bar (50 PSI), are available.

If in a particular application the P_{in} pressure is higher than the recommended value, contact our Sales Office.

The diameter of the suction pipe should ensure that the oil speed will fall within the range: $v = 0.6 - 1.2$ m/s.

(Example 2)

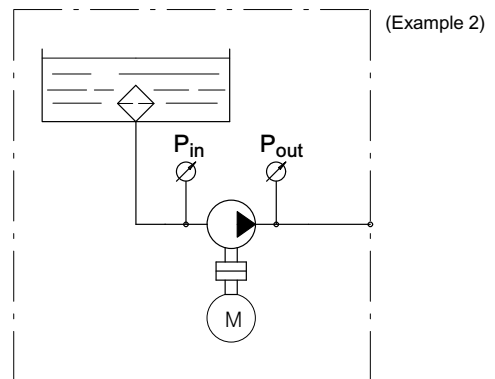
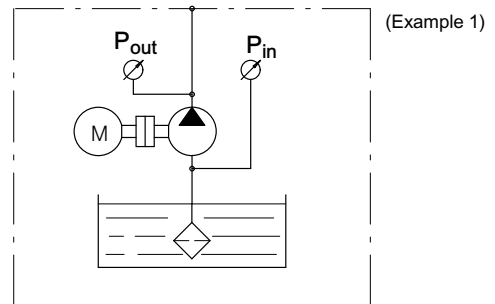

1.5 General precaution

In addition to the recommendations regarding fluids, filtration, coupling, etc., we suggest the following:

- Always check the rotation direction of the pump's drive shaft; it must be compatible with the rotation direction of the pump itself.
- Be particularly careful in cleaning and make sure, when connecting the suction and pressure piping, that no chips, rag threads, teflon tape, etc. get into the pump circulation system.
- Check the tightness of the suction and pressure fittings, the correct positioning of the O-Ring, and make sure there is no dirt between the flange and the pump body.
- The first pump start-up can be facilitated by manually filling the suction piping and the pump itself with oil. To facilitate air bleeding, start the pump with the circuit not pressurised.

- To ensure the best heat distribution inside the tank, make sure the return pipe is not too close to the pump's suction piping. The pipings themselves should be below oil tank level to prevent the formation of foam.
- Do not subject the pumps to operating conditions different from those indicated on section 1.2; for extreme operations, always contact our Technical Department.
- Never use fluids different from those indicated in section 1.2 and do not use fluids incompatible with the pump seals (i.e. HNBR)
- In the event of pump painting, do not use solvents or paints that are incompatible with the material of the seals.
Do not bake paint with excessively high temperatures. Do not paint over the product identification plate.

1.5.1 Directives and standards

- Atex:



Attention: The equipment and protective systems of this catalogue ARE NOT intended for use in potentially explosive atmospheres. Ref: Directive 99/92/EC and Directive 2014/34/UE

- ISO 9001:2015 / ISO 14001:2015

Bucher Hydraulics S.p.A. is certified for research, development and production of directional control valves, power units, gear pumps and motors, electro pumps, cartridge valves and integrated manifolds for hydraulic applications.

1.6 Identifying the rotation direction

The rotation direction of a gear pump is identified by looking at the pump from the front and with the drive gear turned upwards (see figures below).

Pumps with clockwise rotation (D) have a drive gear which turns clockwise, with the suction port on the left and the pressure port on the right.

Pumps with counterclockwise rotation (S) have a drive gear which turns counterclockwise, with the suction port on the right and the pressure port on the left.

The figure also shows the pressure flow inside the pumps as the oil is transferred from the suction port to the pressure port.

As regards reversible pumps (R), the ports are alternatively for suction and pressure.

Pumps with a unidirectional rotation (D or S) have the denomination AP.

Pumps with reversible rotation have the denomination APR.

Pumps with "Low Noise" components have the denomination LN.

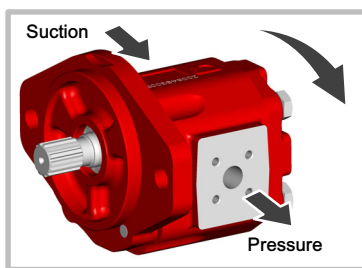

Right-hand rotation D

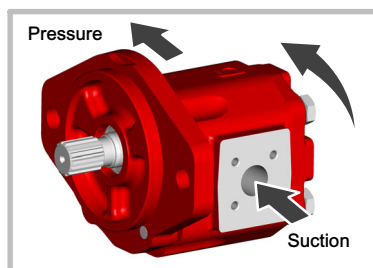

Left-hand rotation S

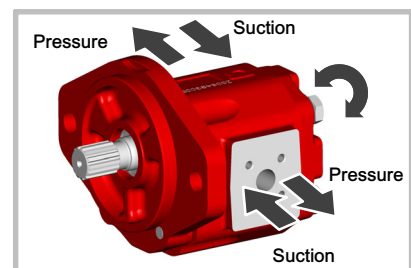

Reversible rotation R

1.7 Motor-pump coupling

Absolutely no radial or axial forces should be transmitted to the drive shaft in the motor-pump coupling.

Such forces cause rapid and irregular wear on the balancing surface of the bushings and gear support, with a consequent worsening in pump performance.

The coupling joint must be able to absorb any discrepancies in the coaxial alignment of the motor-pump shafts without placing any load on the pump shaft.

In the couplings between splined shafts, the connecting sleeve must be free to move along its axis.

The length of the sleeve must be sufficient to cover the splined sections of the motor-pump shafts completely in any position.

A clearance between shaft ends it is necessary.

Make sure that the splined coupling is suitably lubricated to protect it against rapid deterioration.

If there are radial and/or axial loads on the drive shaft, such as when it is driven by a V-belt and pulley or pair of gear wheels, it should be fitted with a front cover with supporting bearings. (See examples in section 3.4.3)

Depending on the pump model concerned, these supports can replace the front cover of the pump or can be fitted in addition to and over the front cover.

1.8 Non-standard symbols used in the text

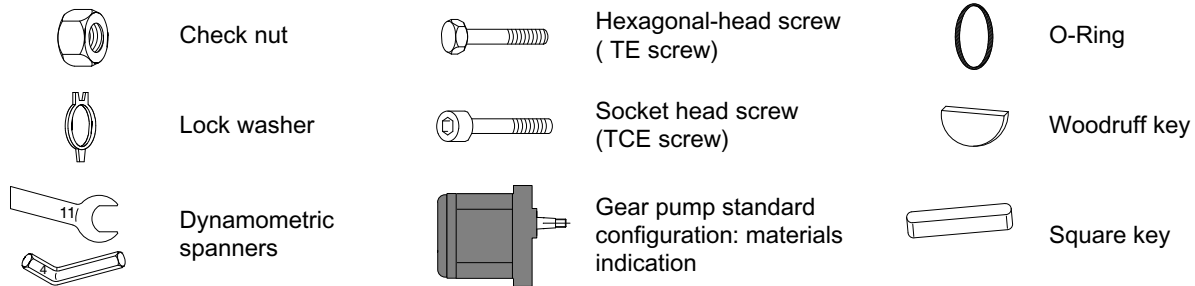

1.9 Calculating the specification of a gear pump

The following parameters are defined:

V_c = (cm³/rev) pump displacement;

n = (rev/min) no. of rpms of the drive shaft;

Q = (l/min) flow rate;

p = (bar) operating pressure;

T = (Nm) drive torque;

N = (kW) Absorbed power;

η_v = (%) volumetric efficiency;

η_m = (%) mechanical efficiency;

η_t = (%) total efficiency

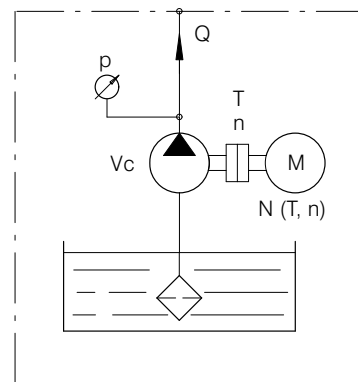

$$Q = \frac{V_c \cdot n}{100000} \cdot \eta_v$$

$$T = 1.59 \cdot \frac{p \cdot V_c}{\eta_m}$$

$$N = \frac{Q \cdot p}{6 \cdot \eta_t}$$

Example

AP212HP/15 $V_c = 15.1 \text{ cm}^3/\text{r}$ $n = 1500 \text{ r/min}$ $p = 200 \text{ bar}$ $\eta_v = 94\%$ $\eta_m = 90\%$ $\eta_t = 84.6\%$

$$Q = \frac{15.1 \cdot 1500}{100000} \cdot 94 = 21.29 \text{ l/min.}$$

$$T = 1.59 \cdot \frac{200 \cdot 15.1}{90} = 53.35 \text{ Nm}$$

$$N = \frac{21.29 \cdot 200}{6 \cdot 84.6} = 8.39 \text{ kW}$$

1.10 Diagrams

Oil viscosity: 37 mm²/s

Oil temperature: 40°C

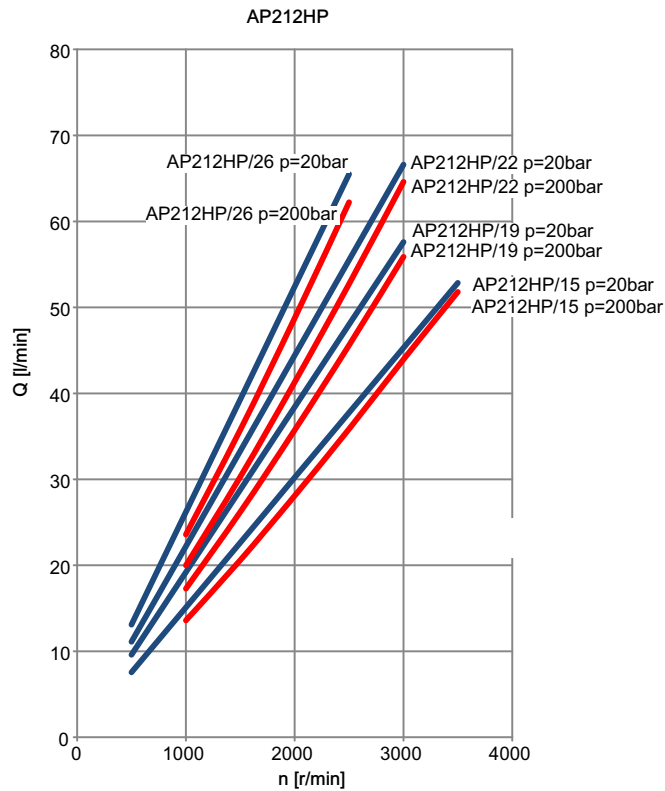

AP212HP/15

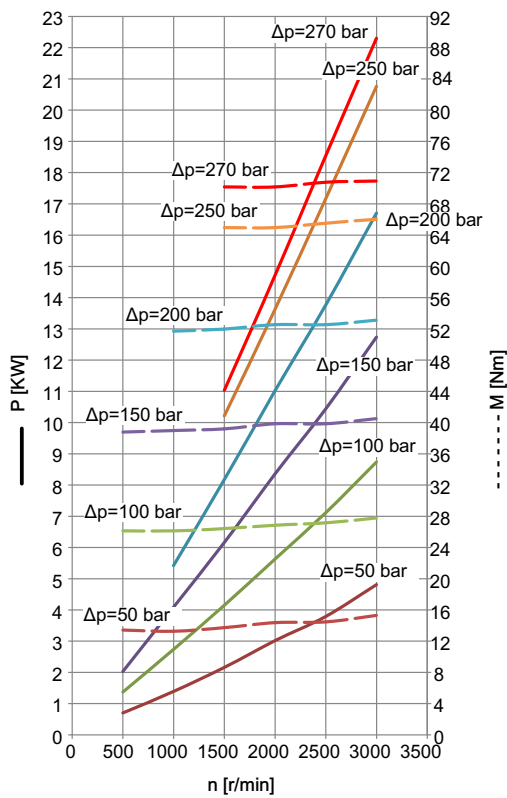

AP212HP/19

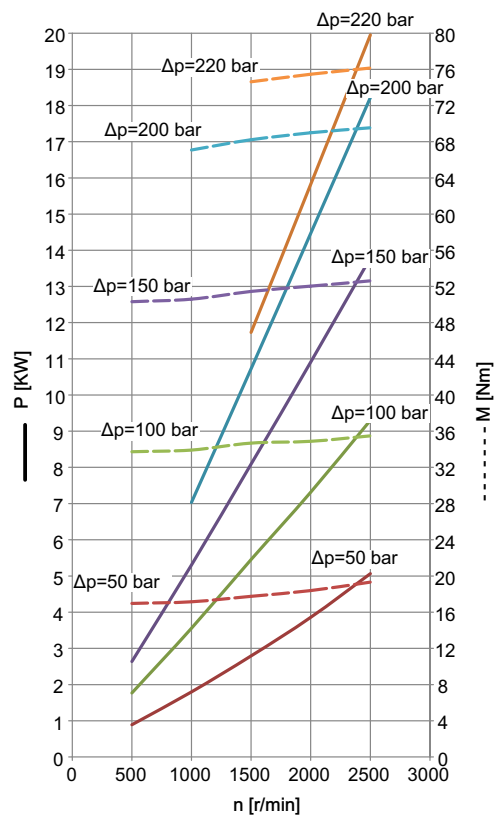

AP212HP/22

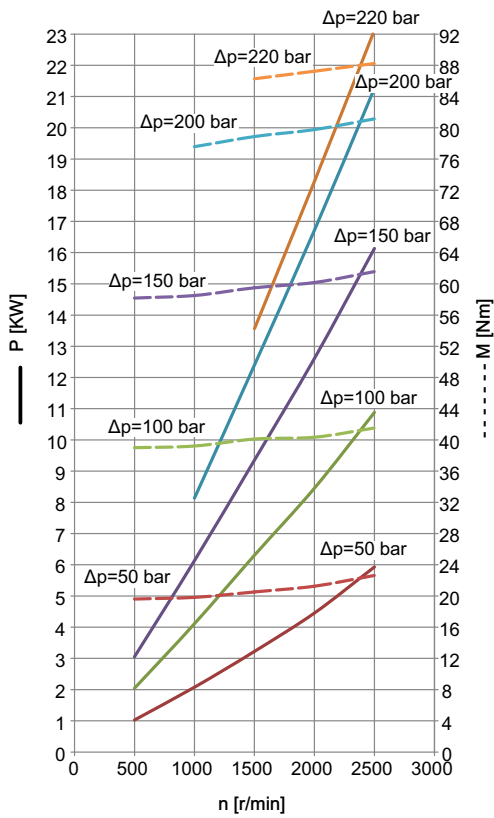

AP212HP/26

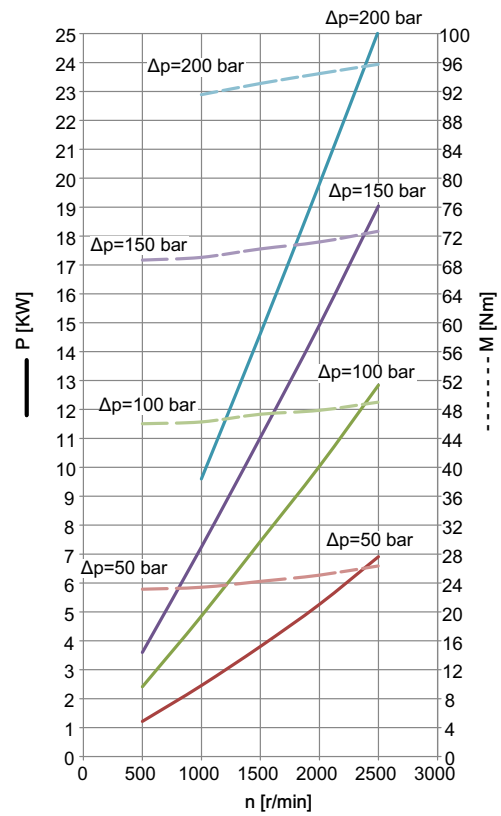

2 Overview standard types

This pumps configuration are considered as "standard".

218	818	225	227	235	245	237	247
887S	880	887S-NPTF	880-NPTF	287S-B	280-B	287S-SAEB	

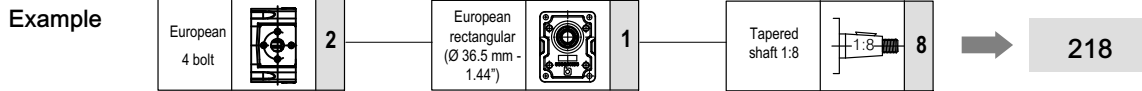





In the next pages, front, rear cover, and seals materials are listed for each pump series.

For ordering purposes, it is enough to outline the complete pump description (for example: AP212HP/15 D 218).

In case of a different configuration request (or a combination of different features, such as port threads, front flange materials, etc.), the description configurator shown in section 3.1 can be easily used.

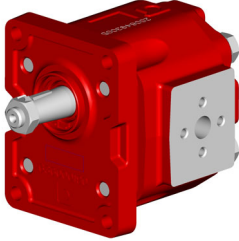
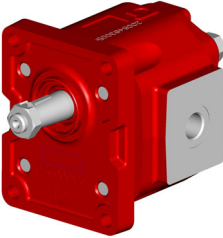
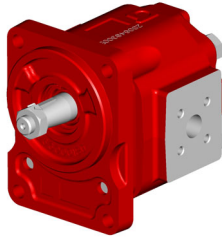
2.1 Standard configuration

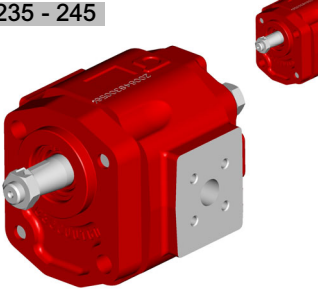
Port type			Front cover type (cast iron made)			Drive shaft		
European 4 bolts flanged		2	European rectangular (Ø 36.5 mm - 1.44")		1	Tapered shaft 1:8		8
German 4 bolts flanged		2	German rectangular (Ø 80 mm - 3.15 inches)		2	Tapered shaft 1:5		5
BSPP Threaded ports		8	Through 2 bolts (Ø 50 mm - 1.97")		3	9 Teeth external spline B17X14 DIN5482		7
SAE Threaded ports		8	Through 2 bolts (Ø 50 mm - 1.97")		4	9 teeth external spline SAE J 498-9T 16/32 DP		7S
NPTF Threaded ports		8	SAE-A 2 bolts (Ø 82.55 mm - 3.25 inches)		8	Straight keyed Ø 15,85 mm - 0.62 inches		0
			SAE-B 2 bolts (Ø 101,6 mm - 4 inches)		8			

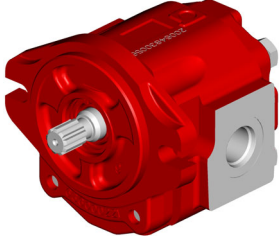
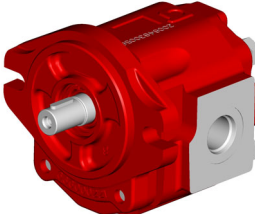
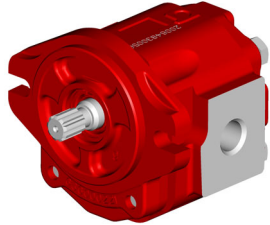
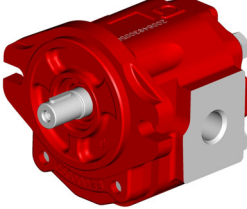
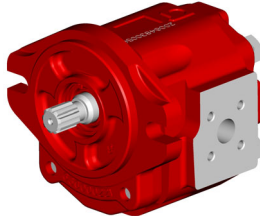
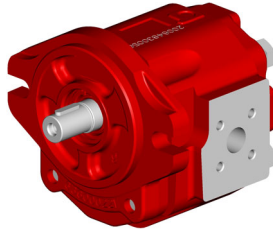
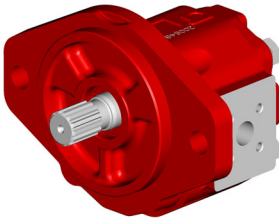
Serie	page	Serie	page	Serie	page
218	14	818	15	225	16
					
227	17	235 - 245	18 19	237 - 247	20 21
					
887S	22	880	23	887S-NPTF	24
					
880-NPTF	25	287S-B	26	280-B	27
					
287S-SAEB	28				
					

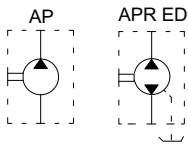

Serie 218

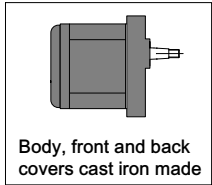
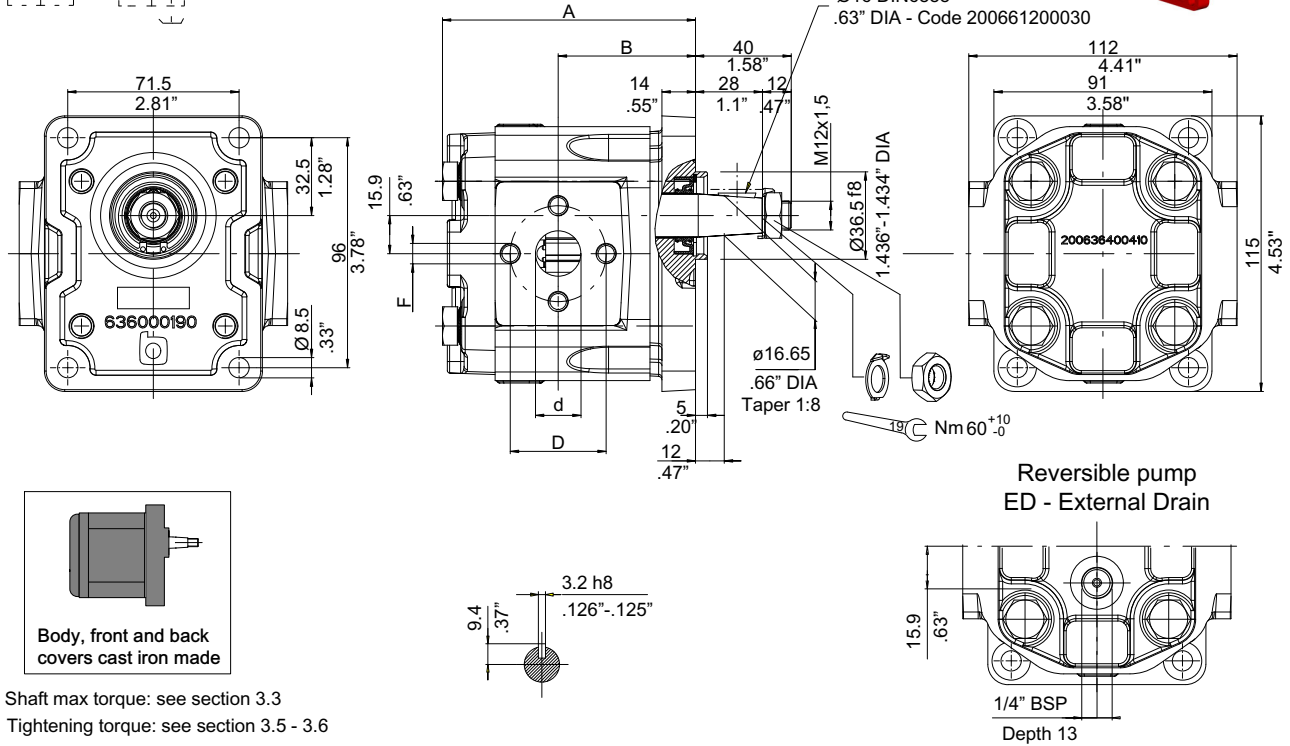
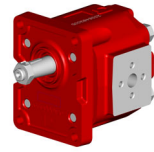

Shaft max torque: see section 3.3
Tightening torque: see section 3.5 - 3.6

Type	Displacement cm ³ /rev		Dimensions				Suction					Pressure				
	AP212HP	AP212HPLN	A	B	d	D	F	d	D	F	d	D	F			
			mm	inch	mm	inch	mm	inch	mm	inch	mm	inch	mm	inch	mm	
15	15.1	15.7	105.6	4.16	57.3	2.26	19	.75	40	1.58	M8X 1.25	13.5	.53	30	1.18	M6X1
19	19.2	19.8	111.6	4.39	60.3	2.37						19	.75	40	1.58	M8X 1.25
22	22.2	23	116.6	4.59	62.55	2.46						19	.75	40	1.58	M8X 1.25
26	26.2	27.1	122.1	4.81	65.55	2.58						19	.75	40	1.58	M8X 1.25
29	28.9	1.764	Displacements on request: please contact our Sales Department													
33	33	2.014														

Clockwise rotation: D		Counter-clockwise rotation: S		Reversible pump External Drain	
Standard	Low Noise	Standard	Low Noise	Standard	Low Noise
AP212HP/15 D 218	AP212HP/15LN D 218	AP212HP/15 S 218	AP212HP/15LN S 218	APR212HP/15 ED 218	APR212HP/15LN ED 218
AP212HP/19 D 218	AP212HP/19LN D 218	AP212HP/19 S 218	AP212HP/19LN S 218	APR212HP/19 ED 218	APR212HP/19LN ED 218
AP212HP/22 D 218	AP212HP/22LN D 218	AP212HP/22 S 218	AP212HP/22LN S 218	APR212HP/22 ED 218	APR212HP/22LN ED 218
AP212HP/26 D 218	AP212HP/26LN D 218	AP212HP/26 S 218	AP212HP/26LN S 218	APR212HP/26 ED 218	APR212HP/26LN ED 218

For reversible pumps alternative inlet and outlet ports have the same sizes as per inlet unidirectional rotation.

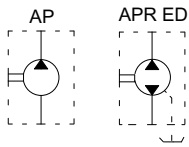

Serie
818

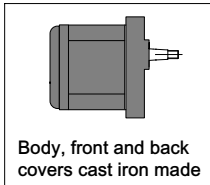
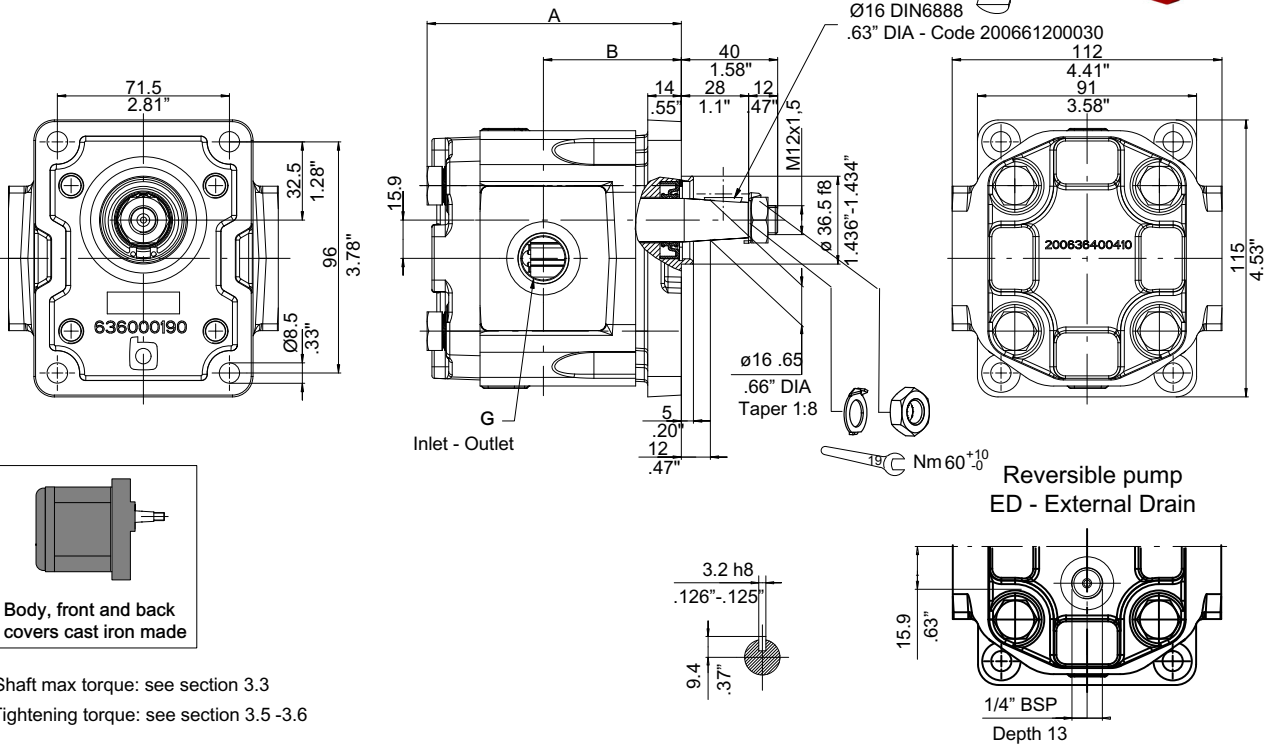
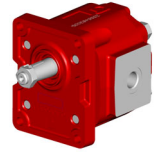

Shaft max torque: see section 3.3
Tightening torque: see section 3.5 -3.6

Type	Displacement cm ³ /rev		Dimensions				Suction	Pressure
	AP212HP	AP212HPLN	A		B		G	G
			mm	inch	mm	inch	BSP	BSP
15	15.1	15.7	105.6	4.16	57.3	2.26	1/2"	3/8"
19	19.2	19.8	111.6	4.39	60.3	2.37	3/4"	1/2"
22	22.2	23	116.6	4.59	62.55	2.46		
26	26.2	27.1	122.1	4.81	65.55	2.58		
29	28.9	1.764	Displacements on request: please contact our Sales Department					
33	33	2.014						

Clockwise rotation: D		Counter-clockwise rotation: S		Reversible pump External Drain	
Standard	Low Noise	Standard	Low Noise	Standard	Low Noise
AP212HP/15 D 818	AP212HP/15LN D 818	AP212HP/15 S 818	AP212HP/15LN S 818	APR212HP/15 ED 818	APR212HP/15LN ED 818
AP212HP/19 D 818	AP212HP/19LN D 818	AP212HP/19 S 818	AP212HP/19LN S 818	APR212HP/19 ED 818	APR212HP/19LN ED 818
AP212HP/22 D 818	AP212HP/22LN D 818	AP212HP/22 S 818	AP212HP/22LN S 818	APR212HP/22 ED 818	APR212HP/22LN ED 818
AP212HP/26 D 818	AP212HP/26LN D 818	AP212HP/26 S 818	AP212HP/26LN S 818	APR212HP/26 ED 818	APR212HP/26LN ED 818

For reversible pumps alternative inlet and outlet ports have the same sizes as per inlet unidirectional rotation.

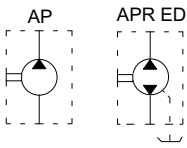

Serie
225

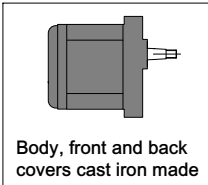
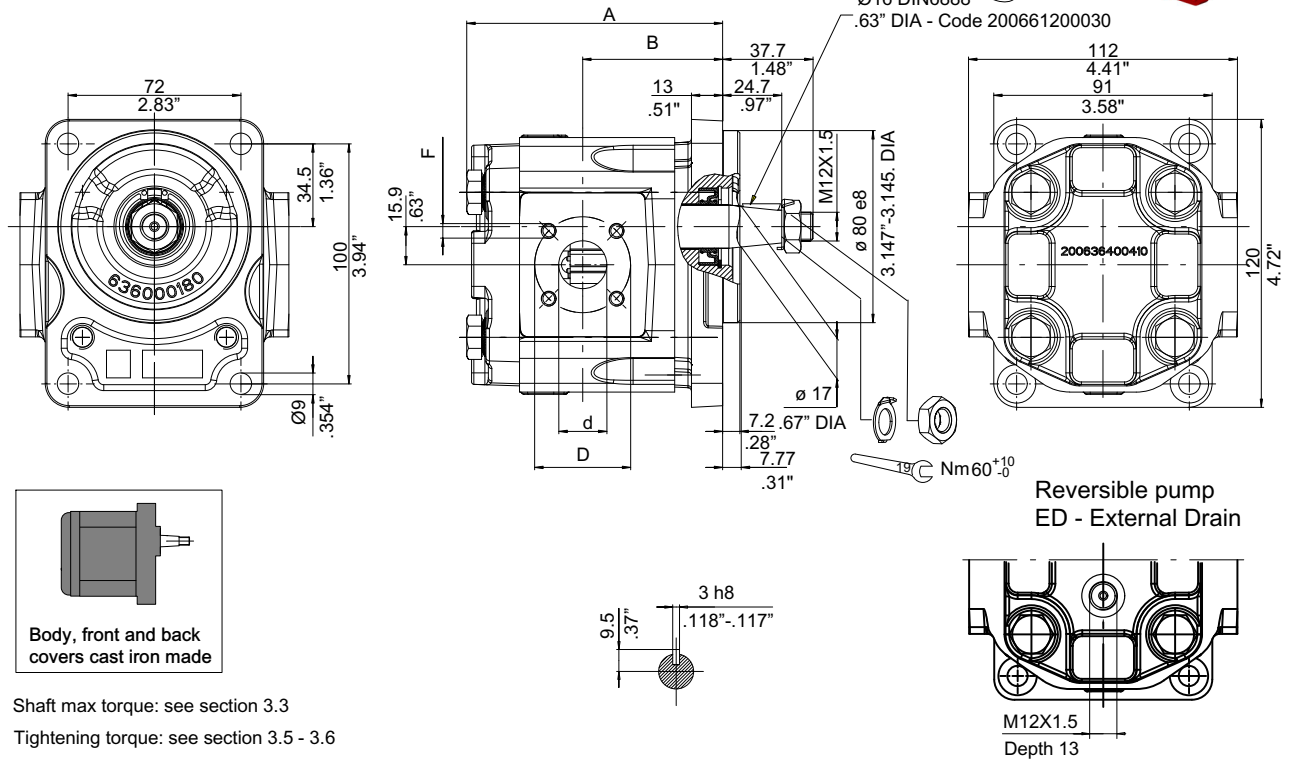

Reversible pump
ED - External Drain

Shaft max torque: see section 3.3
Tightening torque: see section 3.5 - 3.6

Type	Displacement cm ³ /rev		Dimensions				Suction			Pressure						
	AP212HP	AP212HPLN	A	B	d	D	F	d	D	F						
			mm	inch	mm	inch	mm	inch	mm	inch	mm	inch	mm			
15	15.1	15.7	106.6	4.20	58.3	2.30	20	.79	40	1.58	M6X1	15	.59	35	1.38	M6X1
19	19.2	19.8	112.6	4.43	61.3	2.41										
22	22.2	23	117.1	4.61	63.55	2.50										
26	26.2	27.1	123.1	4.85	66.55	2.62										
29	28.9	1.764	Displacements on request: please contact our Sales Department													
33	33	2.014														

Clockwise rotation: D		Counter-clockwise rotation: S		Reversible pump External Drain	
Standard	Low Noise	Standard	Low Noise	Standard	Low Noise
AP212HP/15 D 225	AP212HP/15LN D 225	AP212HP/15 S 225	AP212HP/15LN S 225	APR212HP/15 ED 225	APR212HP/15LN ED 225
AP212HP/19 D 225	AP212HP/19LN D 225	AP212HP/19 S 225	AP212HP/19LN S 225	APR212HP/19 ED 225	APR212HP/19LN ED 225
AP212HP/22 D 225	AP212HP/22LN D 225	AP212HP/22 S 225	AP212HP/22LN S 225	APR212HP/22 ED 225	APR212HP/22LN ED 225
AP212HP/26 D 225	AP212HP/26LN D 225	AP212HP/26 S 225	AP212HP/26LN S 225	APR212HP/26 ED 225	APR212HP/26LN ED 225

For reversible pumps alternative inlet and outlet ports have the same sizes as per inlet unidirectional rotation.

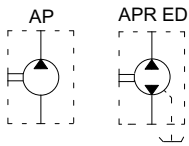

Serie
227

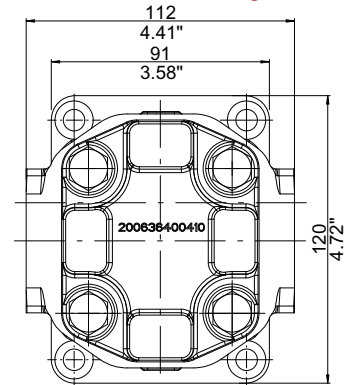
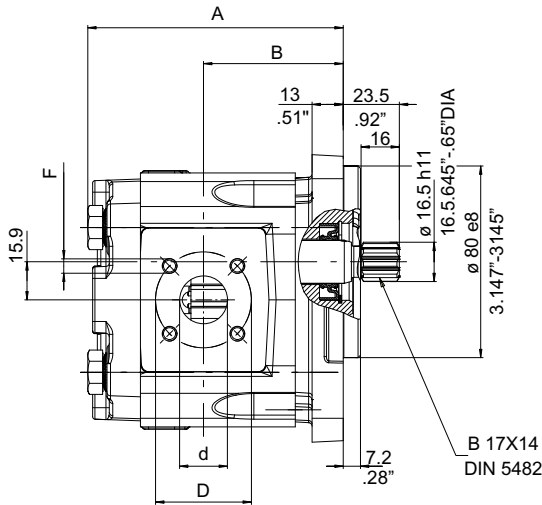
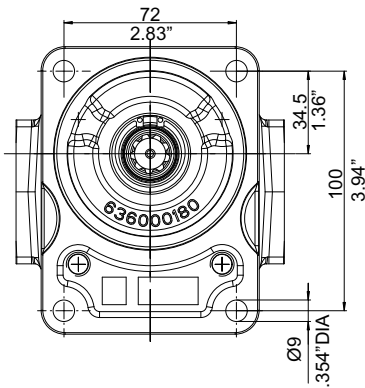

Reversible pump
ED - External Drain

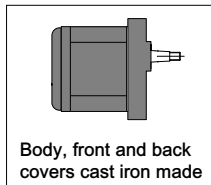
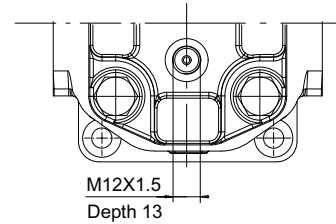

Shaft max torque: see section 3.3

Tightening torque: see section 3.5 - 3.6

Type	Displacement cm ³ /rev		Dimensions				Suction					Pressure				
	AP212HP	AP212HPLN	A		B		d		D		F	d		D		F
			mm	inch	mm	inch	mm	inch	mm	inch	mm	mm	inch	mm	inch	mm
15	15.1	15.7	106.6	4.20	58.3	2.30	20	.79	40	1.58	M6X1	15	.59	35	1.38	M6X1
19	19.2	19.8	112.6	4.43	61.3	2.41										
22	22.2	23	117.1	4.61	63.55	2.50										
26	26.2	27.1	123.1	4.85	66.55	2.62										
29	28.9	1.764	Displacements on request: please contact our Sales Department													
33	33	2.014														

Clockwise rotation: D		Counter-clockwise rotation: S		Reversible pump External Drain	
Standard	Low Noise	Standard	Low Noise	Standard	Low Noise
AP212HP/15 D 227	AP212HP/15LN D 227	AP212HP/15 S 227	AP212HP/15LN S 227	APR212HP/15 ED 227	APR212HP/15LN ED 227
AP212HP/19 D 227	AP212HP/19LN D 227	AP212HP/19 S 227	AP212HP/19LN S 227	APR212HP/19 ED 227	APR212HP/19LN ED 227
AP212HP/22 D 227	AP212HP/22LN D 227	AP212HP/22 S 227	AP212HP/22LN S 227	APR212HP/22 ED 227	APR212HP/22LN ED 227
AP212HP/26 D 227	AP212HP/26LN D 227	AP212HP/26 S 227	AP212HP/26LN S 227	APR212HP/26 ED 227	APR212HP/26LN ED 227

For reversible pumps alternative inlet and outlet ports have the same sizes as per inlet unidirectional rotation.

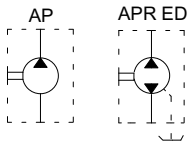

Serie
235

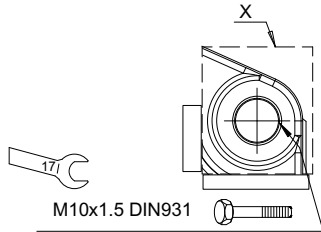
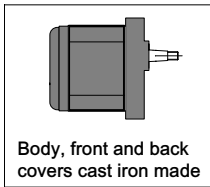
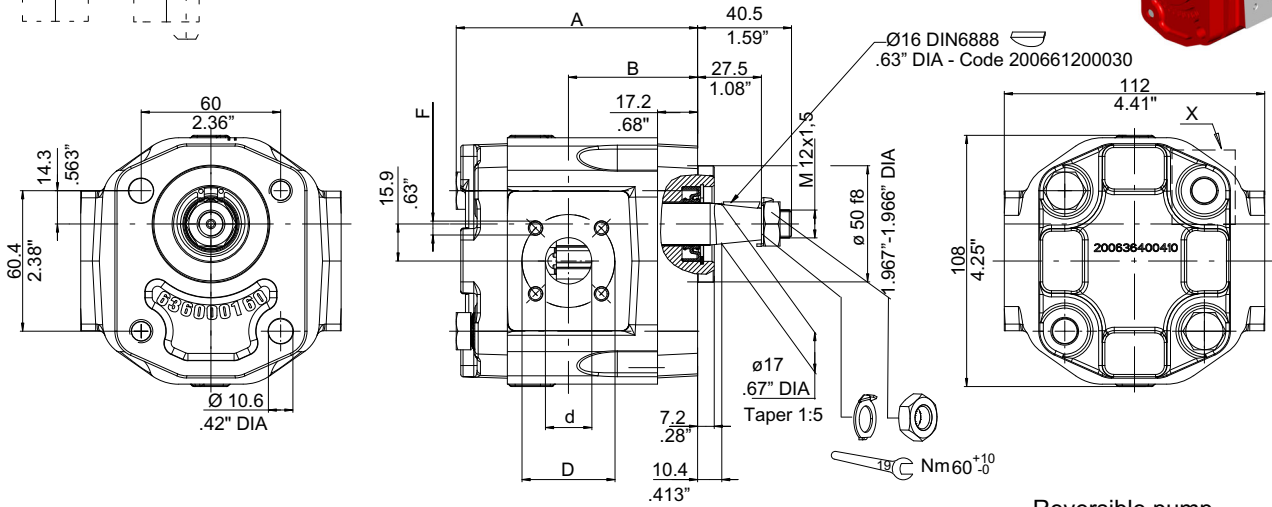
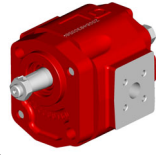

Reversible pump
ED - External Drain

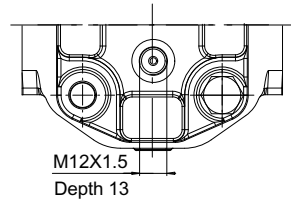

Shaft max torque: see section 3.3
Tightening torque: see section 3.5 - 3.6

Type	Displacement cm ³ /rev		Dimensions				Suction					Pressure				
	AP212HP	AP212HPLN	A	B	d	D	F	d	D	F	d	D	F			
			mm	inch	mm	inch	mm	inch	mm	inch	mm	inch	mm	inch	mm	
15	15.1	15.7	103.8	4.09	55.5	2.19	20	.79	40	1.58	M6X1	15	.59	35	1.38	M6X1
19	19.2	19.8	109.8	4.32	58.5	2.30										
22	22.2	23	114.3	4.5	60.75	2.39										
26	26.2	27.1	120.3	4.74	63.75	2.51										
29	28.9	1.764	Displacements on request: please contact our Sales Department													
33	33	2.014														

Clockwise rotation: D		Counter-clockwise rotation: S		Reversible pump External Drain	
Standard	Low Noise	Standard	Low Noise	Standard	Low Noise
AP212HP/15 D 235	AP212HP/15LN D 235	AP212HP/15 S 235	AP212HP/15LN S 235	APR212HP/15 ED 235	APR212HP/15LN ED 235
AP212HP/19 D 235	AP212HP/19LN D 235	AP212HP/19 S 235	AP212HP/19LN S 235	APR212HP/19 ED 235	APR212HP/19LN ED 235
AP212HP/22 D 235	AP212HP/22LN D 235	AP212HP/22 S 235	AP212HP/22LN S 235	APR212HP/22 ED 235	APR212HP/22LN ED 235
AP212HP/26 D 235	AP212HP/26LN D 235	AP212HP/26 S 235	AP212HP/26LN S 235	APR212HP/26 ED 235	APR212HP/26LN ED 235

For reversible pumps alternative inlet and outlet ports have the same sizes as per inlet unidirectional rotation.

Serie
245

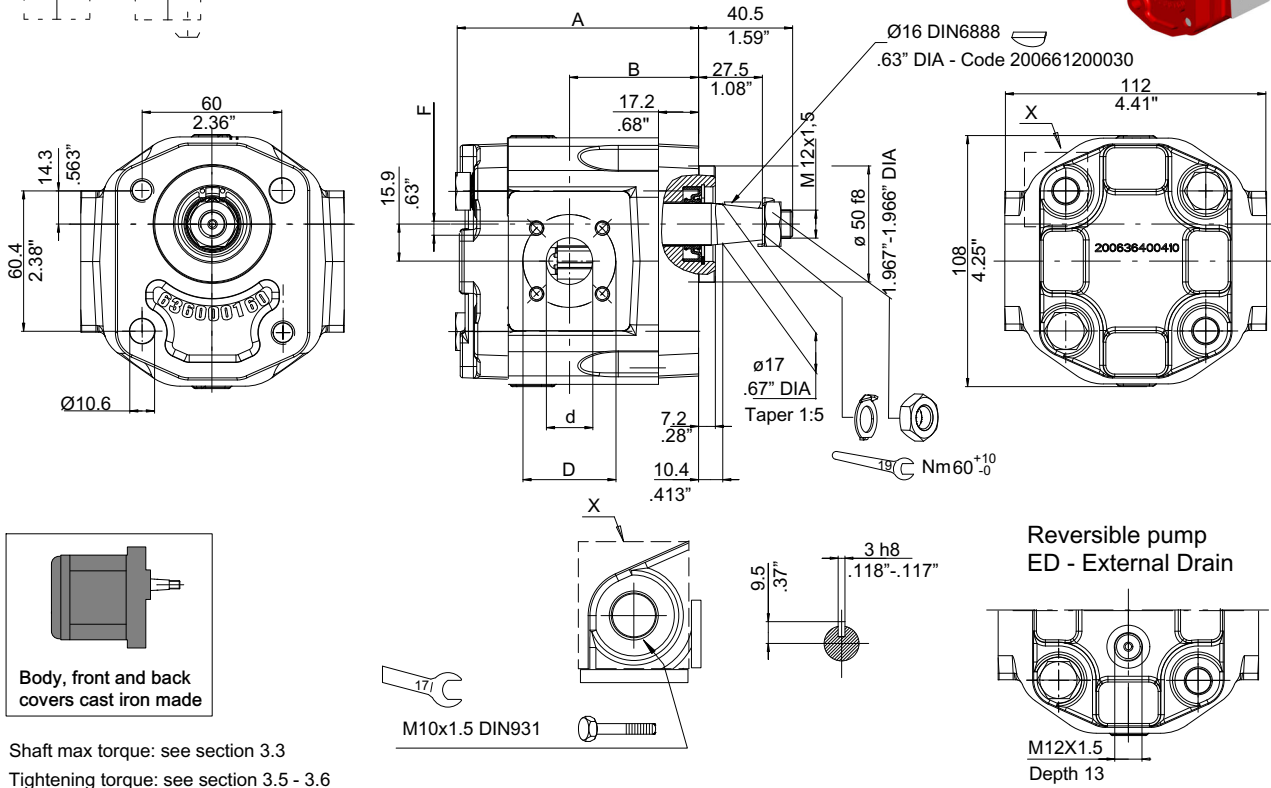
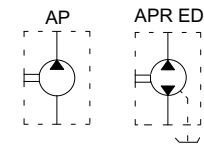

Type	Displacement cm ³ /rev		Dimensions				Suction					Pressure				
	AP212HP	AP212HPLN	A		B		d		D		F	d		D		F
			mm	inch	mm	inch	mm	inch	mm	inch	mm	mm	inch	mm	inch	mm
15	15.1	15.7	103.8	4.09	55.5	2.19	20	.79	40	1.58	M6X1	15	.59	35	1.38	M6X1
19	19.2	19.8	109.8	4.32	58.5	2.30										
22	22.2	23	114.3	4.5	60.75	2.39										
26	26.2	27.1	120.3	4.74	63.75	2.51										
29	28.9	1.764	Displacements on request: please contact our Sales Department													
33	33	2.014														

Clockwise rotation: D		Counter-clockwise rotation: S		Reversible pump External Drain	
Standard	Low Noise	Standard	Low Noise	Standard	Low Noise
AP212HP/15 D 245	AP212HP/15LN D 245	AP212HP/15 S 245	AP212HP/15LN S 245	APR212HP/15 ED 245	APR212HP/15LN ED 245
AP212HP/19 D 245	AP212HP/19LN D 245	AP212HP/19 S 245	AP212HP/19LN S 245	APR212HP/19 ED 245	APR212HP/19LN ED 245
AP212HP/22 D 245	AP212HP/22LN D 245	AP212HP/22 S 245	AP212HP/22LN S 245	APR212HP/22 ED 245	APR212HP/22LN ED 245
AP212HP/26 D 245	AP212HP/26LN D 245	AP212HP/26 S 245	AP212HP/26LN S 245	APR212HP/26 ED 245	APR212HP/26LN ED 245

For reversible pumps alternative inlet and outlet ports have the same sizes as per inlet unidirectional rotation.

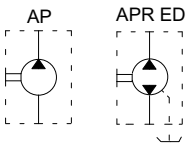

Serie
237

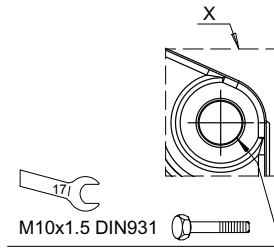
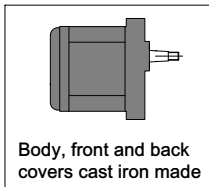
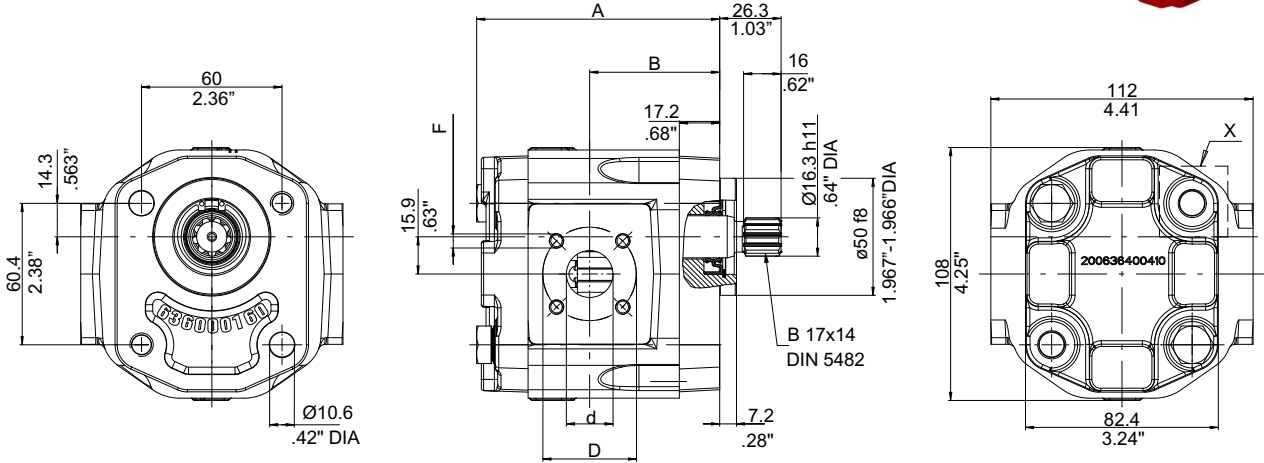

Reversible pump
ED - External Drain

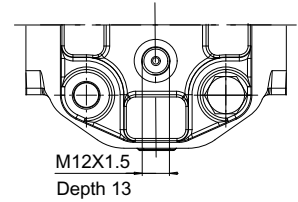

Shaft max torque: see section 3.3

Tightening torque: see section 3.5 - 3.6

Type	Displacement cm ³ /rev		Dimensions				Suction					Pressure				
	AP212HP	AP212HPLN	A	B	d	D	F	d	D	F	d	D	F			
			mm	inch	mm	inch	mm	inch	mm	inch	mm	inch	mm	inch	mm	
15	15.1	15.7	103.8	4.09	55.5	2.19	20	.79	40	1.58	M6X1	15	.59	35	1.38	M6X1
19	19.2	19.8	109.8	4.32	58.5	2.30										
22	22.2	23	114.3	4.5	60.75	2.39										
26	26.2	27.1	120.3	4.74	63.75	2.51										
29	28.9	1.764	Displacements on request: please contact our Sales Department													
33	33	2.014														

Clockwise rotation: D		Counter-clockwise rotation: S		Reversible pump External Drain	
Standard	Low Noise	Standard	Low Noise	Standard	Low Noise
AP212HP/15 D 237	AP212HP/15LN D 237	AP212HP/15 S 237	AP212HP/15LN S 237	APR212HP/15 ED 237	APR212HP/15LN ED 237
AP212HP/19 D 237	AP212HP/19LN D 237	AP212HP/19 S 237	AP212HP/19LN S 237	APR212HP/19 ED 237	APR212HP/19LN ED 237
AP212HP/22 D 237	AP212HP/22LN D 237	AP212HP/22 S 237	AP212HP/22LN S 237	APR212HP/22 ED 237	APR212HP/22LN ED 237
AP212HP/26 D 237	AP212HP/26LN D 237	AP212HP/26 S 237	AP212HP/26LN S 237	APR212HP/26 ED 237	APR212HP/26LN ED 237

For reversible pumps alternative inlet and outlet ports have the same sizes as per inlet unidirectional rotation.

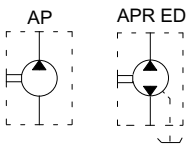

Serie
247

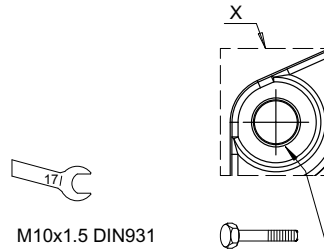
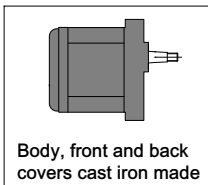
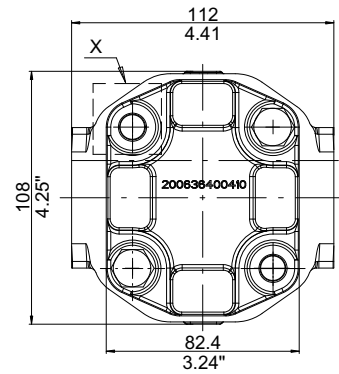
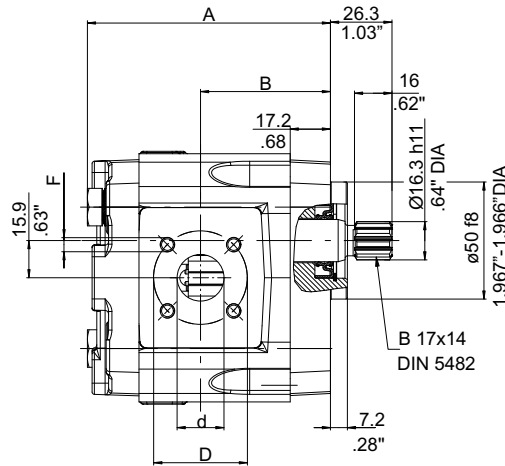
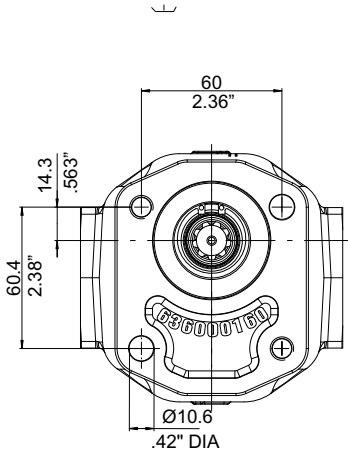

Reversible pump
ED - External Drain

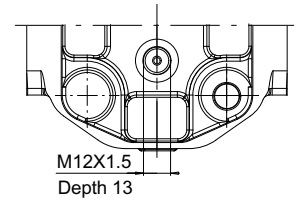

Shaft max torque: see section 3.3

Tightening torque: see section 3.5 - 3.6

Type	Displacement cm ³ /rev		Dimensions				Suction					Pressure				
	AP212HP	AP212HPLN	mm	inch	mm	inch	d	D	F	d	D	F	d	D	F	
15	15.1	15.7	103.8	4.09	55.5	2.19	20	.79	40	1.58	M6X1	15	.59	35	1.38	M6X1
19	19.2	19.8	109.8	4.32	58.5	2.30										
22	22.2	23	114.3	4.5	60.75	2.39										
26	26.2	27.1	120.3	4.74	63.75	2.51										
29	28.9	1.764	Displacements on request: please contact our Sales Department													
33	33	2.014														

Clockwise rotation: D		Counter-clockwise rotation: S		Reversible pump External Drain	
Standard	Low Noise	Standard	Low Noise	Standard	Low Noise
AP212HP/15 D 247	AP212HP/15LN D 247	AP212HP/15 S 247	AP212HP/15LN S 247	APR212HP/15 ED 247	APR212HP/15LN ED 247
AP212HP/19 D 247	AP212HP/19LN D 247	AP212HP/19 S 247	AP212HP/19LN S 247	APR212HP/19 ED 247	APR212HP/19LN ED 247
AP212HP/22 D 247	AP212HP/22LN D 247	AP212HP/22 S 247	AP212HP/22LN S 247	APR212HP/22 ED 247	APR212HP/22LN ED 247
AP212HP/26 D 247	AP212HP/26LN D 247	AP212HP/26 S 247	AP212HP/26LN S 247	APR212HP/26 ED 247	APR212HP/26LN ED 247

For reversible pumps alternative inlet and outlet ports have the same sizes as per inlet unidirectional rotation.

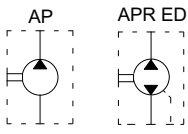

Serie
887S

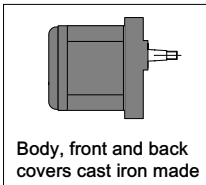
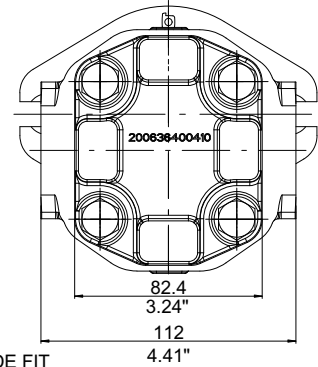
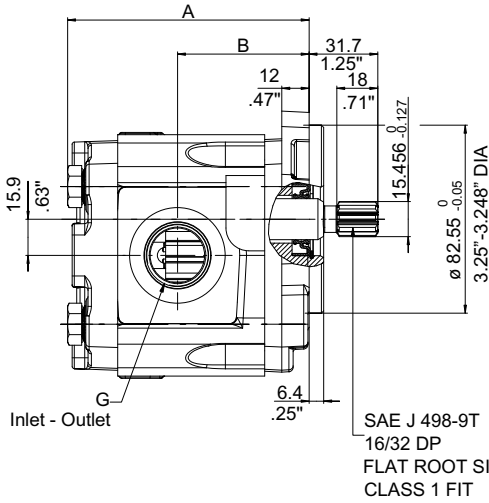
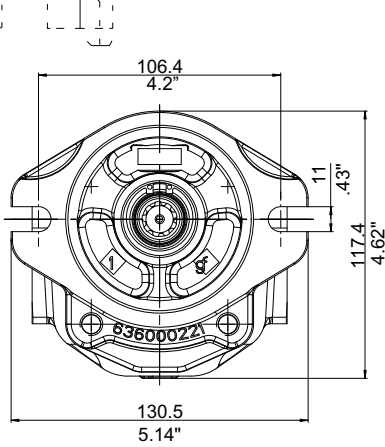
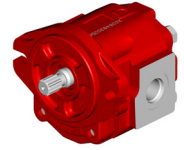

Reversible pump
ED - External Drain

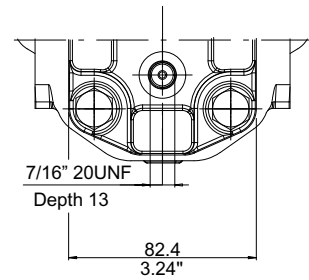

Shaft max torque: see section 3.3
Tightening torque: see section 3.5 - 3.6

Type	Displacement cm ³ /rev		Dimensions				Suction G UNF-2B	Pressure G UNF-2B
	AP212HP	AP212HPLN	A		B			
			mm	inch	mm	inch		
15	15.1	15.7	104.5	4.11	56.3	2.22	1-1/16" 12 (SAE12)	7/8" 14 (SAE10)
19	19.2	19.8	110.5	4.35	59.3	2.33		
22	22.2	23	115	4.52	61.55	2.42		
26	26.2	27.1	121	4.76	64.55	2.54		
29	28.9	1.764	Displacements on request: please contact our Sales Department					
33	33	2.014						

Clockwise rotation: D		Counter-clockwise rotation: S		Reversible pump External Drain	
Standard	Low Noise	Standard	Low Noise	Standard	Low Noise
AP212HP/4.5 D 887S	AP212HP/4.5LN D 887S	AP212HP/4.5 S 887S	AP212HP/4.5LN S 887S	APR212HP/4.5 ED 887S	APR212HP/4.5LN ED 887S
AP212HP/19 D 887S	AP212HP/19LN D 887S	AP212HP/19 S 887S	AP212HP/19LN S 887S	APR212HP/19 ED 887S	APR212HP/19LN ED 887S
AP212HP/22 D 887S	AP212HP/22LN D 887S	AP212HP/22 S 887S	AP212HP/22LN S 887S	APR212HP/22 ED 887S	APR212HP/22LN ED 887S
AP212HP/26 D 887S	AP212HP/26LN D 887S	AP212HP/26 S 887S	AP212HP/26LN S 887S	APR212HP/26 ED 887S	APR212HP/26LN ED 887S

For reversible pumps alternative inlet and outlet ports have the same sizes as per inlet unidirectional rotation.

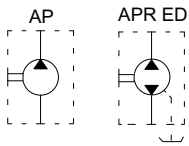

Serie
880

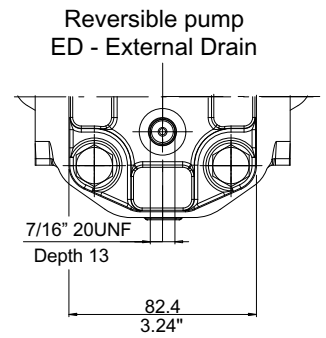
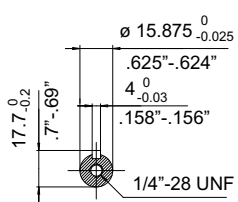
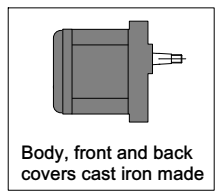
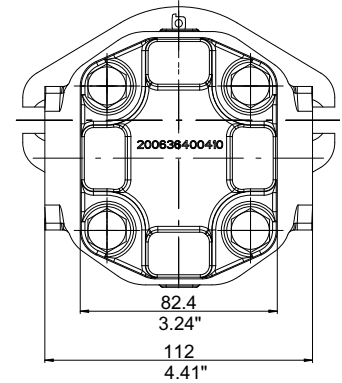
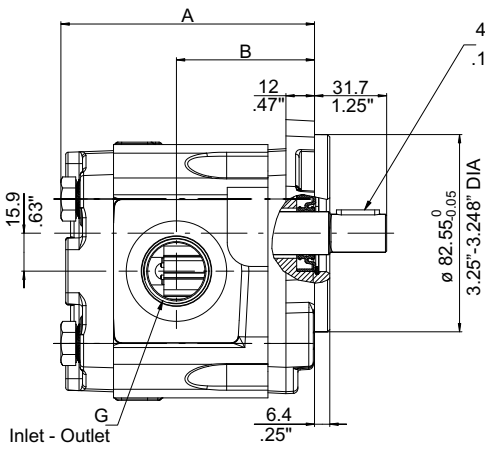
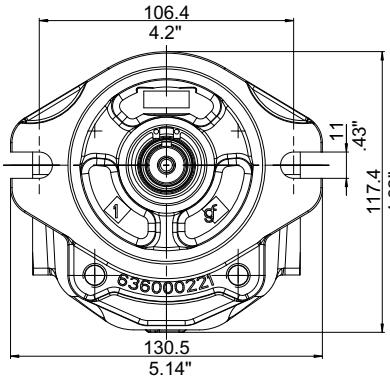
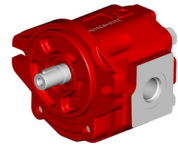

Reversible pump
ED - External Drain

Shaft max torque: see section 3.3
Tightening torque: see section 3.5 - 3.6

Type	Displacement cm ³ /rev		Dimensions				Suction G UNF-2B	Pressure G UNF-2B
	AP212HP	AP212HPLN	A		B			
			mm	inch	mm	inch		
15	15.1	15.7	104.5	4.11	56.3	2.22	1-1/16" 12 (SAE12)	7/8" 14 (SAE10)
19	19.2	19.8	110.5	4.35	59.3	2.33		
22	22.2	23	115	4.52	61.55	2.42		
26	26.2	27.1	121	4.76	64.55	2.54		
29	28.9	1.764	Displacements on request: please contact our Sales Department					
33	33	2.014						

Clockwise rotation: D		Counter-clockwise rotation: S		Reversible pump External Drain	
Standard	Low Noise	Standard	Low Noise	Standard	Low Noise
AP212HP/15 D 880	AP212HP/15LN D 880	AP212HP/15 S 880	AP212HP/15LN S 880	APR212HP/15 ED 880	APR212HP/15LN ED 880
AP212HP/19 D 880	AP212HP/19LN D 880	AP212HP/19 S 880	AP212HP/19LN S 880	APR212HP/19 ED 880	APR212HP/19LN ED 880
AP212HP/22 D 880	AP212HP/22LN D 880	AP212HP/22 S 880	AP212HP/22LN S 880	APR212HP/22 ED 880	APR212HP/22LN ED 880
AP212HP/26 D 880	AP212HP/26LN D 880	AP212HP/26 S 880	AP212HP/26LN S 880	APR212HP/26 ED 880	APR212HP/26LN ED 880

For reversible pumps alternative inlet and outlet ports have the same sizes as per inlet unidirectional rotation.

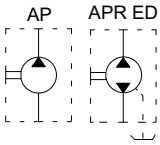

Serie
887S-NPTF

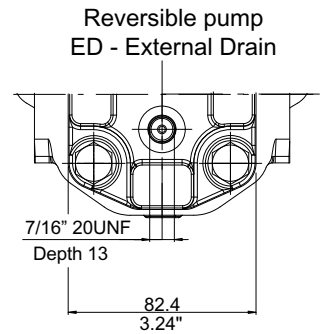
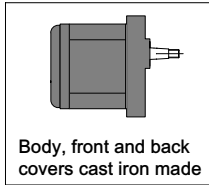
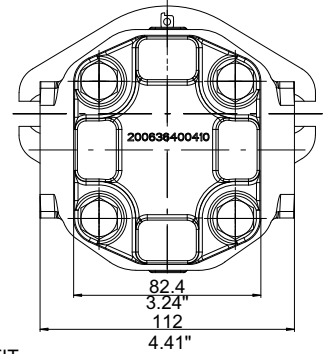
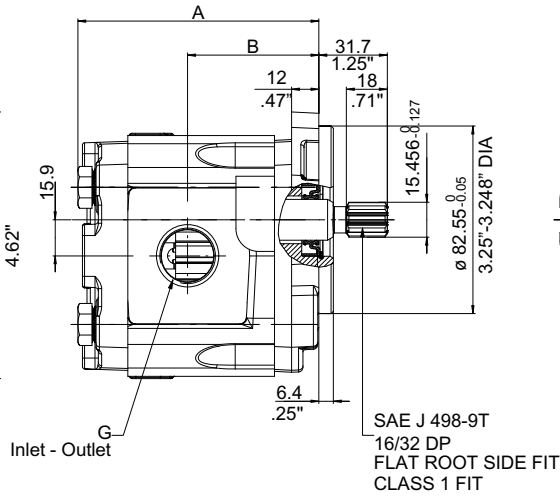
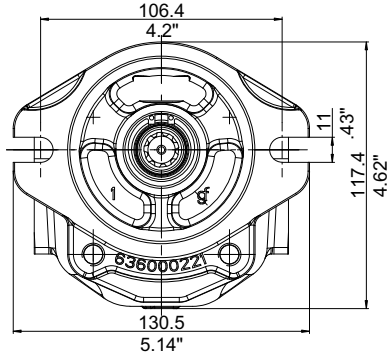
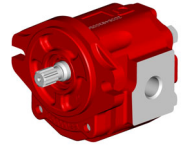

Shaft max torque: see section 3.3
Tightening torque: see section 3.5 - 3.6

Type	Displacement cm ³ /rev		Dimensions				Suction G NPTF	Pressure G NPTF
	AP212HP	AP212HPLN	mm	inch	mm	inch		
15	15.1	15.7	104.5	4.11	56.3	2.22	3/4"	1/2"
19	19.2	19.8	110.5	4.35	59.3	2.33		
22	22.2	23	115	4.52	61.55	2.42		
26	26.2	27.1	121	4.76	64.55	2.54		
29	28.9	1.764	Displacements on request: please contact our Sales Department					
33	33	2.014						

Clockwise rotation: D		Counter-clockwise rotation: S		Reversible pump External Drain	
Standard	Low Noise	Standard	Low Noise	Standard	Low Noise
AP212HP/15 D 887S-NPTF	AP212HP/15LN D 887S-NPTF	AP212HP/15 S 887S-NPTF	AP212HP/15LN S 887S-NPTF	APR212HP/15 ED 887S-NPTF	APR212HP/15LN ED 887S-NPTF
AP212HP/19 D 887S-NPTF	AP212HP/19LN D 887S-NPTF	AP212HP/19 S 887S-NPTF	AP212HP/19LN S 887S-NPTF	APR212HP/19 ED 887S-NPTF	APR212HP/19LN ED 887S-NPTF
AP212HP/22 D 887S-NPTF	AP212HP/22LN D 887S-NPTF	AP212HP/22 S 887S-NPTF	AP212HP/22LN S 887S-NPTF	APR212HP/22 ED 887S-NPTF	APR212HP/22LN ED 887S-NPTF
AP212HP/26 D 887S-NPTF	AP212HP/26LN D 887S-NPTF	AP212HP/26 S 887S-NPTF	AP212HP/26LN S 887S-NPTF	APR212HP/26 ED 887S-NPTF	APR212HP/26LN ED 887S-NPTF

For reversible pumps alternative inlet and outlet ports have the same sizes as per inlet unidirectional rotation.

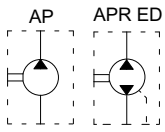

Serie
880-NPTF

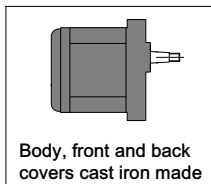
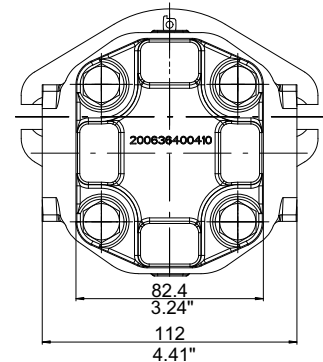
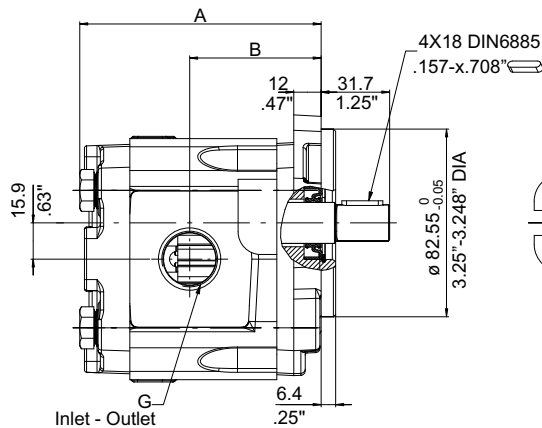
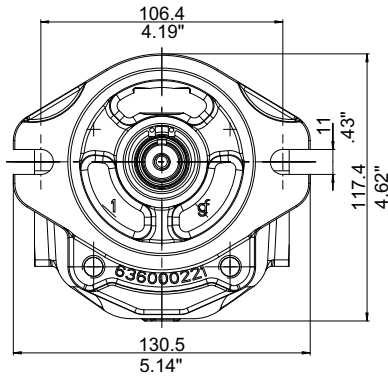
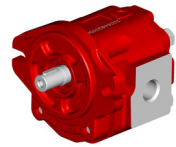

Shaft max torque: see section 3.3

Tightening torque: see section 3.5 - 3.6

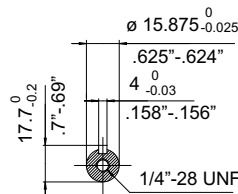

Reversible pump
ED - External Drain

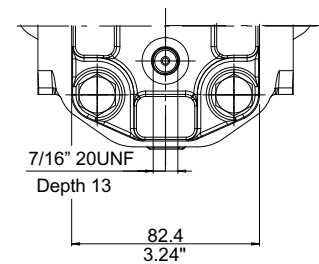

Type	Displacement cm ³ /rev		Dimensions				Suction G NPTF	Pressure G NPTF
	AP212HP	AP212HPLN	A		B			
			mm	inch	mm	inch		
15	15.1	15.7	104.5	4.11	56.3	2.22	3/4"	1/2"
19	19.2	19.8	110.5	4.35	59.3	2.33		
22	22.2	23	115	4.52	61.55	2.42		
26	26.2	27.1	121	4.76	64.55	2.54		
29	28.9	1.764	Displacements on request: please contact our Sales Department					
33	33	2.014						

Clockwise rotation: D		Counter-clockwise rotation: S		Reversible pump External Drain	
Standard	Low Noise	Standard	Low Noise	Standard	Low Noise
AP212HP/15 D 880-NPTF	AP212HP/15LN D 880-NPTF	AP212HP/15 S 880-NPTF	AP212HP/15LN S 880-NPTF	APR212HP/15 ED 880-NPTF	APR212HP/15LN ED 880-NPTF
AP212HP/19 D 880-NPTF	AP212HP/19LN D 880-NPTF	AP212HP/19 S 880-NPTF	AP212HP/19LN S 880-NPTF	APR212HP/19 ED 880-NPTF	APR212HP/19LN ED 880-NPTF
AP212HP/22 D 880-NPTF	AP212HP/22LN D 880-NPTF	AP212HP/22 S 880-NPTF	AP212HP/22LN S 880-NPTF	APR212HP/22 ED 880-NPTF	APR212HP/22LN ED 880-NPTF
AP212HP/26 D 880-NPTF	AP212HP/26LN D 880-NPTF	AP212HP/26 S 880-NPTF	AP212HP/26LN S 880-NPTF	APR212HP/26 ED 880-NPTF	APR212HP/26LN ED 880-NPTF

For reversible pumps alternative inlet and outlet ports have the same sizes as per inlet unidirectional rotation.

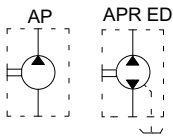

Serie
287S-B

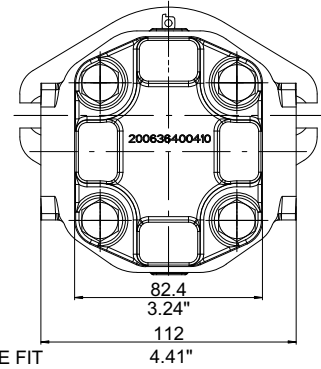
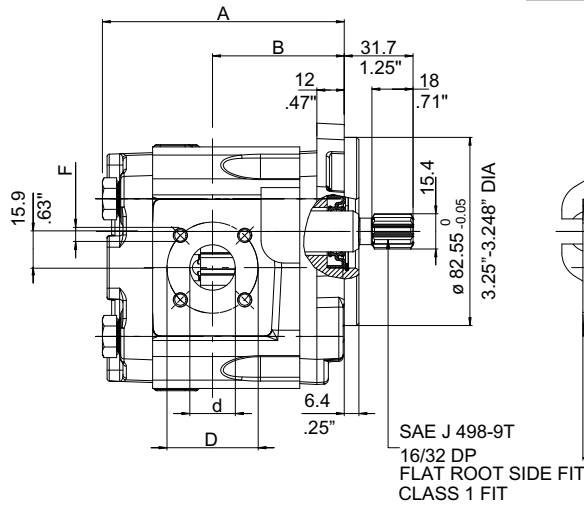
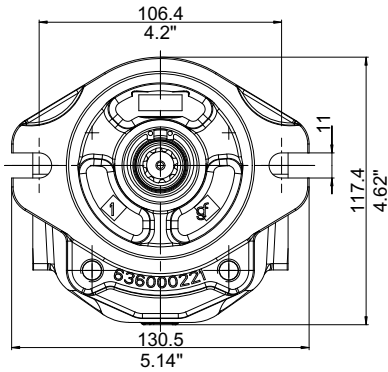
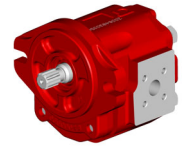

Reversible pump
ED - External Drain

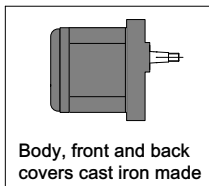
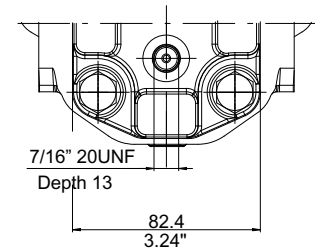

Body, front and back covers cast iron made

Shaft max torque: see section 3.3
Tightening torque: see section 3.5 - 3.6

Type	Displacement cm ³ /rev		Dimensions				Suction			Pressure						
	AP212 HP	AP212HP LN	mm	inch	mm	inch	d	D	F	d	D	F				
15	15.1	15.7	104.5	4.11	56.3	2.22	20	.79	40	1.58	M6X1	15	.59	35	1.38	M6X1
19	19.2	19.8	110.5	4.35	59.3	2.33										
22	22.2	23	115	4.52	61.55	2.42										
26	26.2	27.1	121	4.76	64.55	2.54										
29	28.9	1.764	Displacements on request: please contact our Sales Department													
33	33	2.014														

Clockwise rotation: D		Counter-clockwise rotation: S		Reversible pump External Drain	
Standard	Low Noise	Standard	Low Noise	Standard	Low Noise
AP212HP/15 D287S-B	AP212HP/15LN D287S-B	AP212HP/15 S287S-B	AP212HP/15LN S287S-B	APR212HP/15 ED287S-B	APR212HP/15LN ED287S-B
AP212HP/19 D287S-B	AP212HP/19LN D287S-B	AP212HP/19 S287S-B	AP212HP/19LN S287S-B	APR212HP/19 ED287S-B	APR212HP/19LN ED287S-B
AP212HP/22 D287S-B	AP212HP/22LN D287S-B	AP212HP/22 S287S-B	AP212HP/22LN S287S-B	APR212HP/22 ED287S-B	APR212HP/22LN ED287S-B
AP212HP/26 D287S-B	AP212HP/26LN D287S-B	AP212HP/26 S287S-B	AP212HP/26LN S287S-B	APR212HP/26 ED287S-B	APR212HP/26LN ED287S-B

For reversible pumps alternative inlet and outlet ports have the same sizes as per inlet unidirectional rotation.

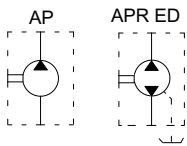

Serie
280-B

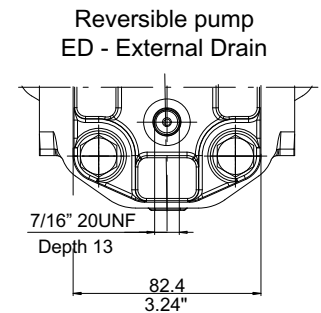
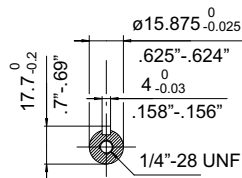
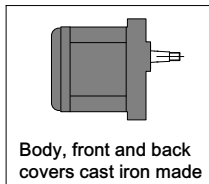
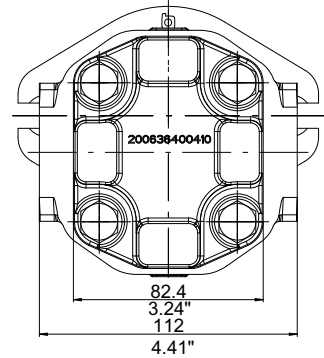
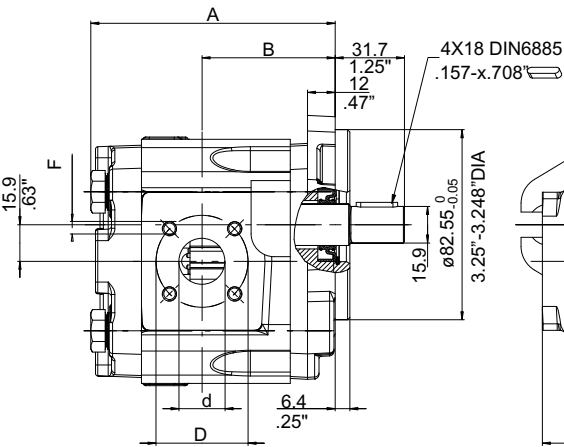
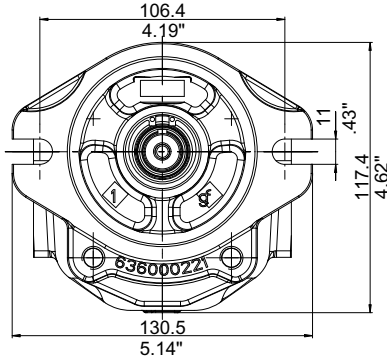
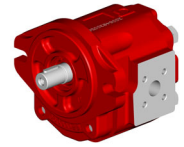

Shaft max torque: see section 3.3
Tightening torque: see section 3.5 - 3.6

Type	Displacement cm ³ /rev		Dimensions				Suction					Pressure				
	AP212 HP	AP212HP LN	mm	inch	mm	inch	d	inch	D	inch	F	d	inch	D	inch	F
15	15.1	15.7	104.5	4.11	56.3	2.22	20	.79	40	1.58	M6X1	15	.59	35	1.38	M6X1
19	19.2	19.8	110.5	4.35	59.3	2.33										
22	22.2	23	115	4.52	61.55	2.42										
26	26.2	27.1	121	4.76	64.55	2.54										
29	28.9	1.764	Displacements on request: please contact our Sales Department													
33	33	2.014														

Clockwise rotation: D		Counter-clockwise rotation: S		Reversible pump External Drain	
Standard	Low Noise	Standard	Low Noise	Standard	Low Noise
AP212HP/15 D 280-B	AP212HP/15LN D 280-B	AP212HP/15 S 280-B	AP212HP/15LN S 280-B	APR212HP/15 ED 280-B	APR212HP/15LN ED 280-B
AP212HP/19 D 280-B	AP212HP/19LN D 280-B	AP212HP/19 S 280-B	AP212HP/19LN S 280-B	APR212HP/19 ED 280-B	APR212HP/19LN ED 280-B
AP212HP/22 D 280-B	AP212HP/22LN D 280-B	AP212HP/22 S 280-B	AP212HP/22LN S 280-B	APR212HP/22 ED 280-B	APR212HP/22LN ED 280-B
AP212HP/26 D 280-B	AP212HP/26LN D 280-B	AP212HP/26 S 280-B	AP212HP/26LN S 280-B	APR212HP/26 ED 280-B	APR212HP/26LN ED 280-B

For reversible pumps alternative inlet and outlet ports have the same sizes as per inlet unidirectional rotation.

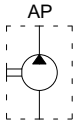

Serie
287S-SAEB

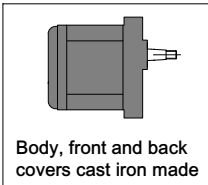
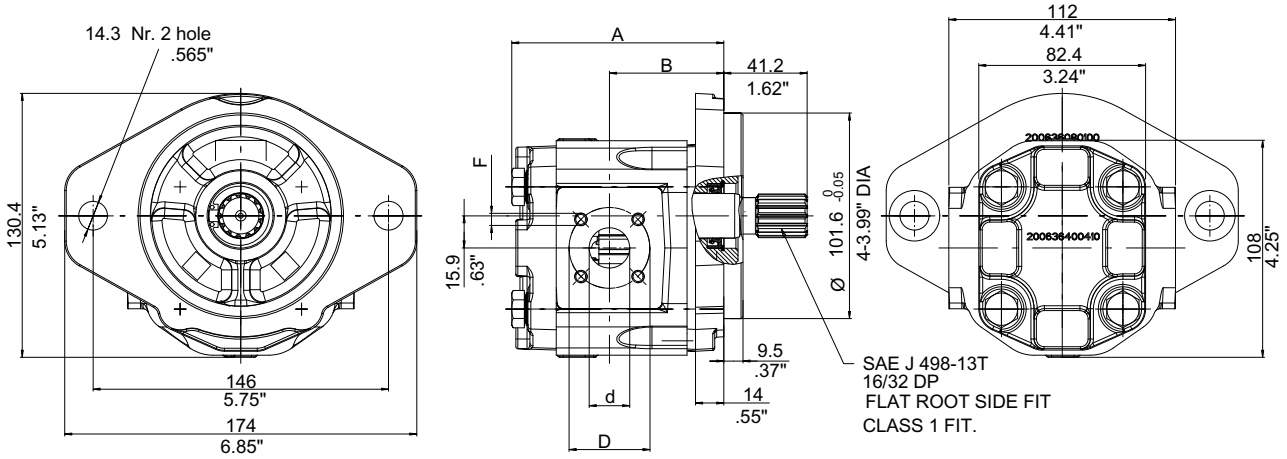
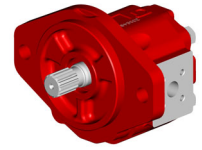

Attention! It is not possible to change the rotation direction. Please order always with the right code

Shaft max torque: see section 3.3

Tightening torque: see section 3.5 - 3.6

Type	Displacement cm ³ /rev		Dimensions				Suction					Pressure				
	AP212HP	AP212HPLN	A	B	d	D	F	d	D	F	d	D	F			
			mm	inch	mm	inch	mm	inch	mm	inch	mm	inch	mm	inch	mm	
15	15.1	15.7	104.5	4.11	56.3	2.18	20	.79	40	1.58	M6X1	15	.59	35	1.38	M6X1
19	19.2	19.8	110.5	4.35	59.3	2.33										
22	22.2	23	115	4.52	61.55	2.42										
26	26.2	27.1	121	4.76	64.55	2.54										
29	28.9	29.9	125	4.92	66.55	2.62	24	.94	55	2.16	M8x 1.25					
33	33	34.1	131	5.15	69.55	2.74										

Clockwise rotation: D		Counter-clockwise rotation: S	
Standard	Low Noise	Standard	Low Noise
AP212HP/15 D 287S-SAEB	AP212HP/15LN D 287S-SAEB	AP212HP/15 S 287S-SAEB	AP212HP/15LN S 287S-SAEB
AP212HP/19 D 287S-SAEB	AP212HP/19LN D 287S-SAEB	AP212HP/19 S 287S-SAEB	AP212HP/19LN S 287S-SAEB
AP212HP/22 D 287S-SAEB	AP212HP/22LN D 287S-SAEB	AP212HP/22 S 287S-SAEB	AP212HP/22LN S 287S-SAEB
AP212HP/26 D 287S-SAEB	AP212HP/26LN D 287S-SAEB	AP212HP/26 S 287S-SAEB	AP212HP/26LN S 287S-SAEB

For reversible pumps alternative inlet and outlet ports have the same sizes as per inlet unidirectional rotation.

3 AP212HP Single pump customised versions

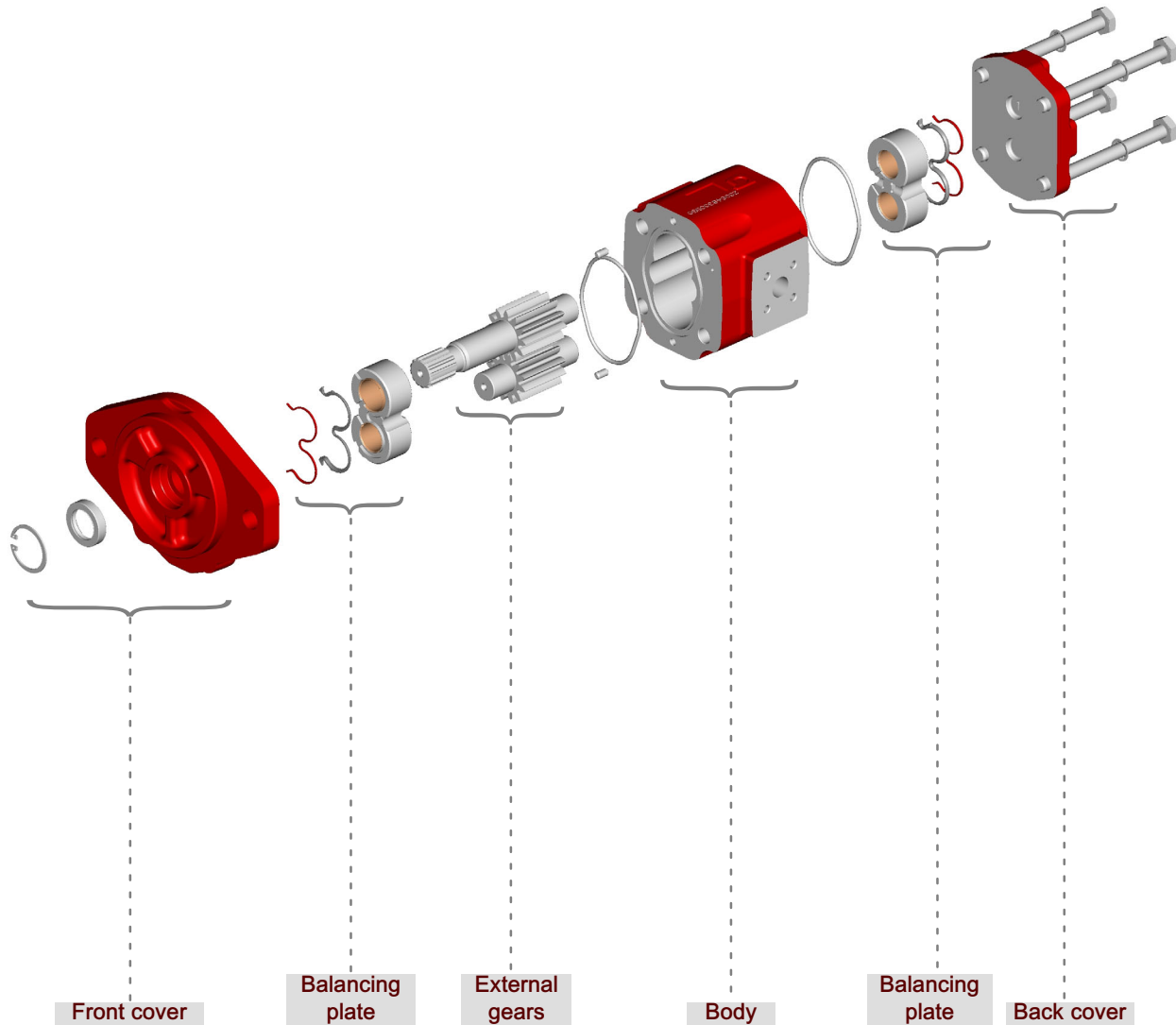

In this section, a single AP212HP pump can be configured and customized.

AP212HP wide availability of covers, bodies, gears and seals sets provides great flexibility to AP212HP pump range and allows several different pump configurations.

In order to simplify the selection of the desired pump combination, a 'configurator form' is available and, by filling it out, it will guide you in the pump creation process.

3.1 Single pump customised versions order example

A	P	2	1	2	H	P	/	1	5	L	N	-	S	-	A	0	S	-	8	A	-	G	H			-	A
<div style="border: 1px solid black; padding: 5px;"> <p>Function AP= single gear pump - unidirectional APR = single gear pump - reversible</p> <p>Series 212HP</p> <p>Displacement 15= 15.1 cm³/rev 19= 19.2 cm³/rev 22= 22.2 cm³/rev 26= 26.2 cm³/rev 29= 28.9 cm³/rev 33= 33 cm³/rev</p> <p>Version Omitted if 12 teeth standard LN= 12 teeth Low Noise version</p> <p>Rotation S = left-hand rotation D = Right-hand rotation Omitted if reversible version</p> <p>Shaft end code see section 3.3</p> <p>Shaft seal material type code see section 3.4.1</p> <p>Front cover series/material with/without bearing code see section 3.4.2 and 3.4.3</p> <p>Type of ports code see section 3.5</p> <p>Inlet/outlet port size code combination see section 3.5</p> <p>Back cover type see section 3.6</p> <p>BHRE section : Version - Progressive number (omitted)</p> </div>																											

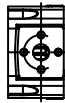
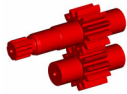

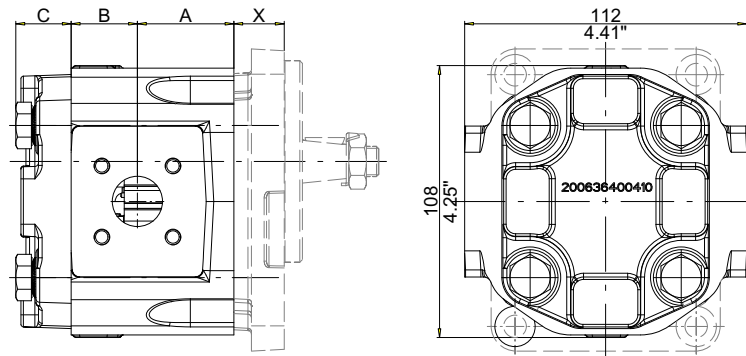

3.2 Single pump dimensions



Pump size	A		B		C*	
	mm	inches	mm	inches	mm	inches
AP212HP/15	38.3	1.51	26.3	1.04	22 (28 with tie rod + nut for tandem)	0.87" (1.10" with tie rod + nut for tandem)
AP212HP/19	41.3	1.63	29.3	1.15		
AP212HP/22	43.55	1.71	31.55	1.24		
AP212HP/26	46.55	1.83	34.55	1.36		
AP212HP/29	48.55	1.91	36.55	1.44		
AP212HP/33	51.55	2.03	39.55	1.56		

C*: dimensions with standard cast iron back cover and screws.
For other back covers dimension see section 3.6

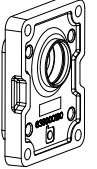
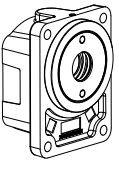
3.2.1 Cast iron front cover dimensions

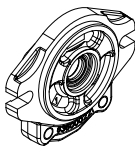
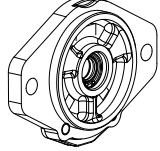
Front cover type	x		Front cover type	x	
	mm	inches		mm	inches
German rectangular 	20	0.79	European rectangular 	19	0.75
Bearing support German version 	48.5	1.91	Through 2 bolts 	17.2	0.68
SAE-A 2 bolts 	19.5	0.77	SAE-B 2 bolts 	18.2	0.72

3.3 Shaft end code

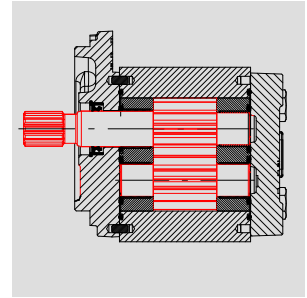
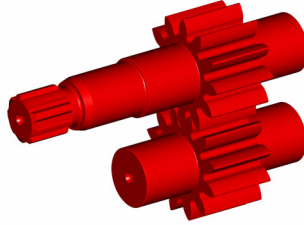

A P 2 1 2 H P / 1 5 - S - A 0 S - 8 A - V E 1 6 - A

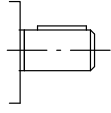
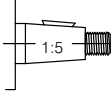
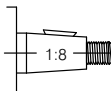
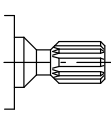
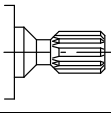
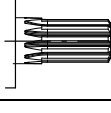
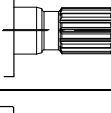
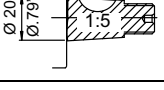
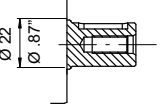
Shaft end shape	Shaft end ordering code	Max torque	
	Straight keyed Ø 15,85 mm - 0.62 inches	S	T max = 65 Nm
	Tapered shaft 1:5	G	T max = 135 Nm
	Tapered shaft 1:8	E	T max = 135 Nm
	9 Teeth external spline B17X14 DIN5482	D	T max = 110 Nm
	9 teeth external spline SAE J 498-9T 16/32 DP	A	T max = 90 Nm
	11 teeth external spline SAE J 498-11T 16/32 DP	T	T max = 140 Nm
	13 teeth external spline SAE J 498-13T 16/32 DP	B	T max = 270 Nm
	Bearing application 1:5	See section 3.4.3	T max = 100 Nm
	Bearing application Straight 22 mm - 0.87 inches	See section 3.4.3	T max = 100 Nm

3.4 Front cover

3.4.1 Shaft seal material

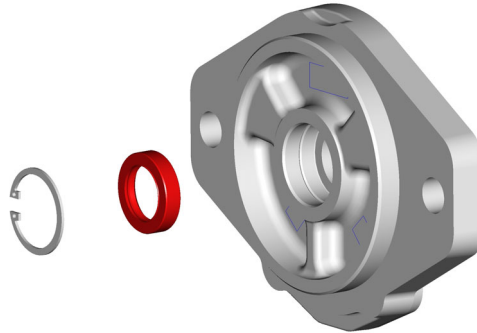

A P 2 1 2 H P / 1 5 - S - A 0 S - 8 A - V E 1 6 - A



Shaft seal Type/material	Ordering code
Shaft seal pump NBR (standard)	0
Shaft seal pump HNBR	1
FPM (VITON)	2
Shaft seal front bearing application	see section 3.4.3

3.4.2 Cast iron front cover type

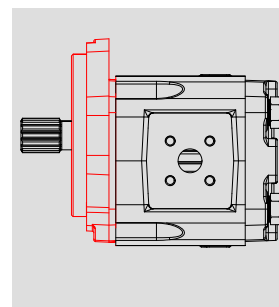
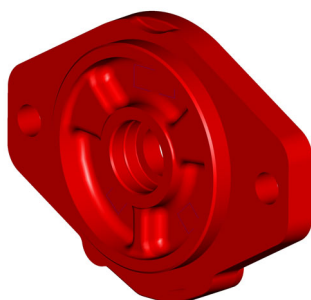

A P 2 1 2 H P / 1 5 - S - A 0 S - 8 A - V E 1 6 - A

Type	Cast iron		Cast iron + bearing	
	Shape	Ordering code	Shape	Ordering code
German rectangular (Ø 80 mm - 3.15 inches)		B		see section 3.4.3
European rectangular (Ø 36.5 mm - 1.44")		E		*
Through 2 bolts (Ø 50 mm - 1.97")		H		*
Through 2 bolts (Ø 50 mm - 1.97")		M		*
SAE-A 2 bolts (Ø 82.55 mm - 3.25 inches)		S		*
SAE-B 2 bolts (Ø 101,6 mm - 4 inches)		V		

Cast iron front cover dimensions: see standard pumps data sheet

* Please contact our Sales Department

3.4.3 Front bearing application

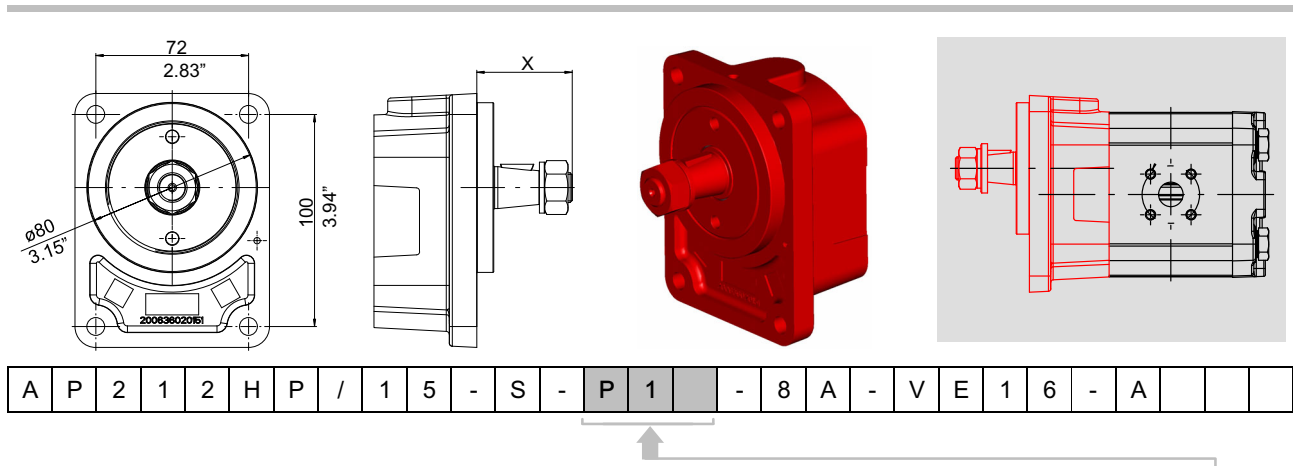

A	P	2	1	2	H	P	/	1	5	-	S	-	P	1	-	8	A	-	V	E	1	6	-	A		
---	---	---	---	---	---	---	---	---	---	---	---	---	---	---	---	---	---	---	---	---	---	---	---	---	--	--

	+	 T max = 100 Nm X = 45 mm (1.77 inches)	+	Shaft seal material: HNBR	=	P1
	+	 T max = 100 Nm Straight 22 mm - 0.87 inches X = 48.5 mm (1.91 inches)	+	Shaft seal material: HNBR	=	C1

Front bearing should be utilized in presence of radial and/or axial load. If there are radial and/or axial loads on the drive shaft, such as when it is driven by a V-belt and pulley or pair of gear wheels, it should be fitted with a front cover with supporting bearings. (See example 1 and 2)

Depending on the pump model concerned, these supports can replace the front cover of the pump or can be fitted in addition to and over the front cover.

(Example 1)

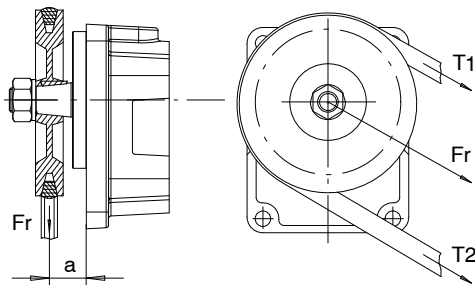

Maximum radial force admitted 1000h

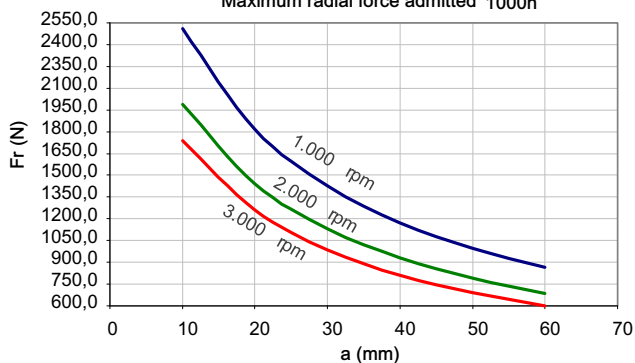

(Example 2)

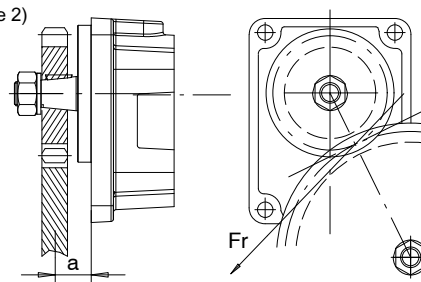

Maximum radial force admitted 5000h

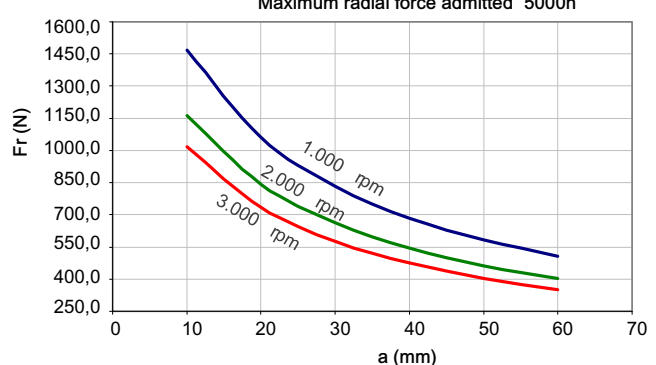

3.5 Cast iron body

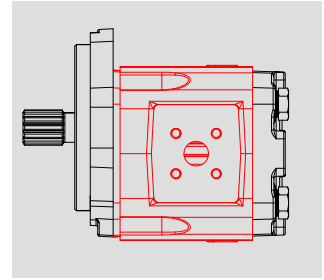
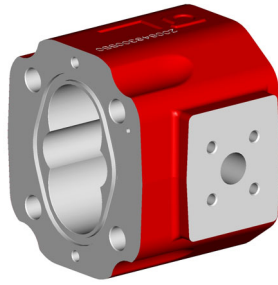

For reversible pumps alternative inlet and outlet ports have the same sizes as per inlet unidirectional rotation.

A	P	2	1	2	H	P	/	1	5	-	S	-	A	0	S	-	8	A	-	V	E	1	6	-	A		
---	---	---	---	---	---	---	---	---	---	---	---	---	---	---	---	---	---	---	---	---	---	---	---	---	---	--	--

Port type		Ordering code	Displacement	Dimension (mm - inch)		Ordering code
				Suction	Pressure	
	without	0	All			0
			19-22-26 29-33			D

Port type		Ordering code	Displacement	Dimension (mm - inch)		Ordering code
				Suction	Pressure	
	metric	1	15	On demand		B
			19-22-26			C
			29-33			D
	BSPP threaded ports	4	15	1/2"	3/8"	B
			19-22-26	3/4"	1/2"	C
			29-33	1"	1/2"	D

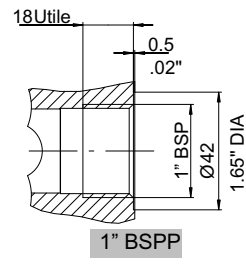
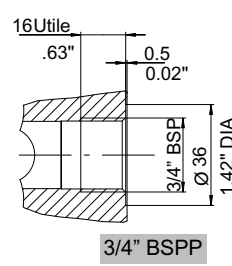
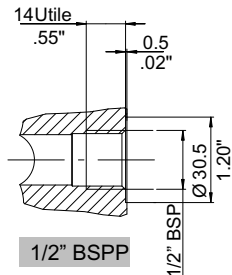
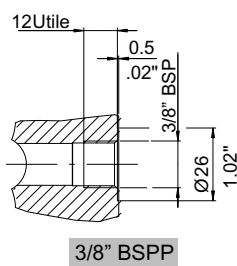

Recommended tightening torque for work port fittings - Nm / lbf

BSP - ISO 228-1	3/8" BSP	1/2" BSP	3/4" BSP	1" BSP
With copper washer (ISO 1179-1)	40 / 29.5 (±10%)	60 / 44.3 (±10%)	90 / 66.4 (±10%)	100 / 73.8 (±10%)
With rubber washer or steel (ISO 1179-1)	35 / 25.8 (±10%)	60 / 44.3 (±10%)	70 / 51.7 (±10%)	90 / 66.4 (±10%)

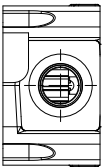
Port type	Ordering code	Displacement	Dimension (mm - inch)		Ordering code	
			Suction	Pressure		
	SAE threaded ports	8	all	1-1/16" 12 UNF-2B (SAE12)	7/8" 14 UNF-2B (SAE10)	A

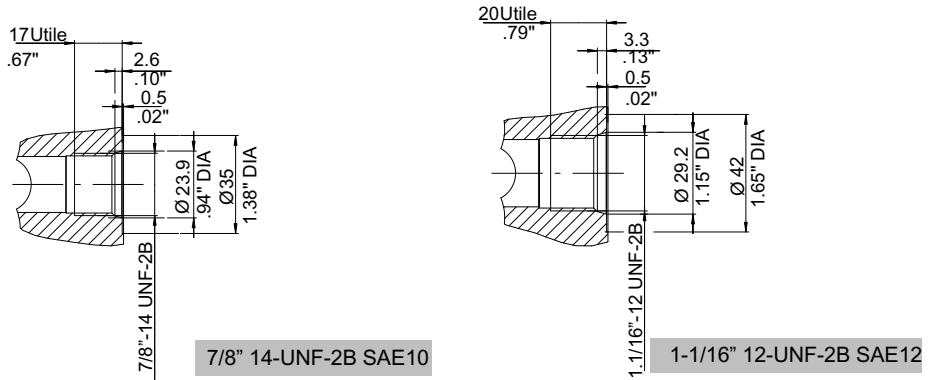

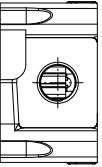
	NPTF threaded ports	6	15-19-22-26	3/4"	1/2"	B
			29-33	1"	1/2"	E

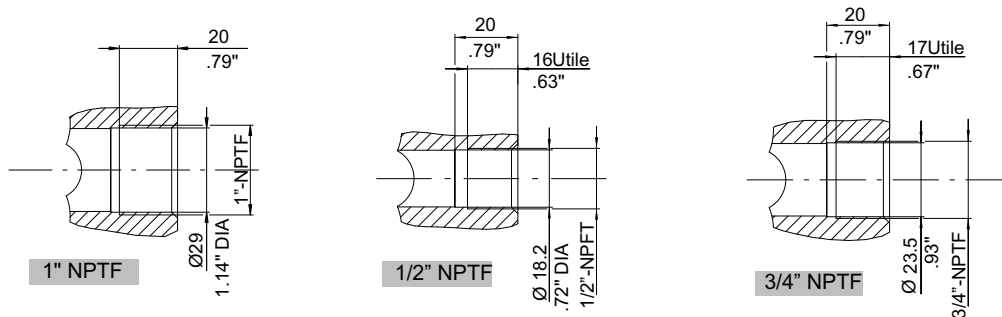

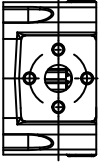
	European 4 bolt	3	15	19 - .75 (d) 40 - 1.58 (D) M8 (F)	13.5 - .53 (d) 30 - 1.18 (D) M6 (F)	B
			19-22-26-29-33	19 - .75 (d) 40 - 1.58 (D) M8 (F)	19 - .75 (d) 40 - 1.58 (D) M8 (F)	C

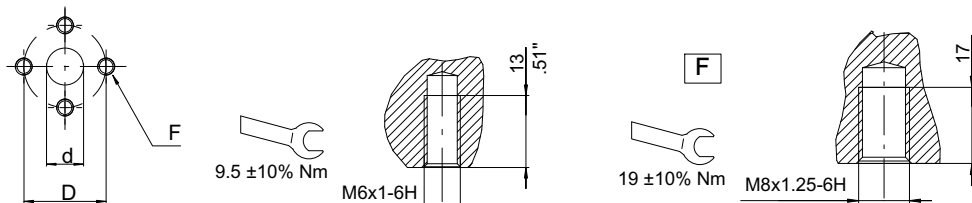

Recommended tightening torque for work port fittings - Nm / lbf

UN-UNF - ISO 263	SAE10 - 7/8-14UNF	SAE12 - 1-1/16-12UNF
With O-Ring seal (ISO 11926-1)	60 / 44.3 (±10%)	90 / 66.4 (±10%)

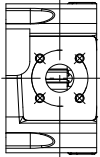
Type	Ordering code	Displacement	Dimension (mm - inch)		Ordering code
			Suction	Pressure	
 German 4 bolt flanged	2	15-19-22-26	20 - .79 (d) 40 - 1.58 (D) M6 (F)	15 - .59 (d) 35 - 1.38 (D) M6 (F) <u>287-S SAEB: M5 (F)?</u>	B
		29-33 (287-S SAEB)	24 - .95 (d) 55 - 2.17 (D) M8 (F) (287-S SAEB)		

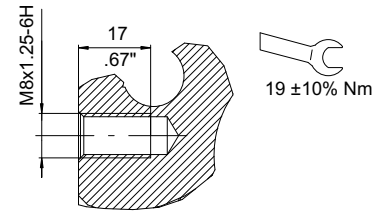
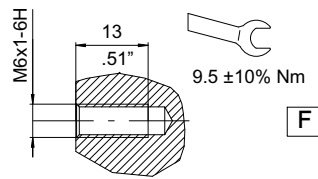
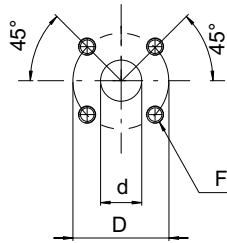

Other ports	9	If the requested port type is not included in the previous versions, please indicate number "9" and specify the details in the request note
-------------	---	---

3.5.1 Body seals material: HNBR (standard)

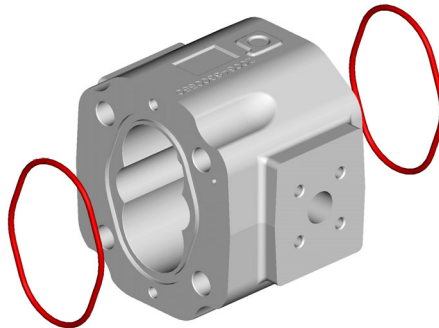

3.6.3 Cast iron back cover with relief valve VI (internal drain)

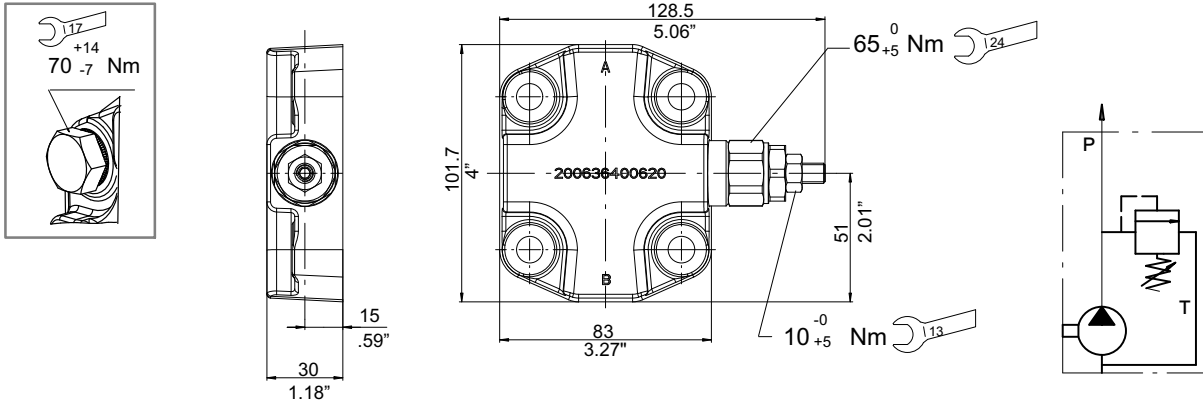

A	P	2	1	2	H	P	/	1	5	-	S	-	A	1	S	-	8	A	-	V	I	*	*	-	A		
---	---	---	---	---	---	---	---	---	---	---	---	---	---	---	---	---	---	---	---	---	---	---	---	---	---	--	--

Type	Ordering code
Cast iron back cover with relief valve. Return to internal pump suction	VI**

** pressure set value (bar) - in example: VI15 = 150 bar



Attention: Please take care that when the relief valve open, oil temperature increase quickly. These conditions have effect in the pump performances and life

3.6.4 Cast iron back cover with relief valve VE (external drain)

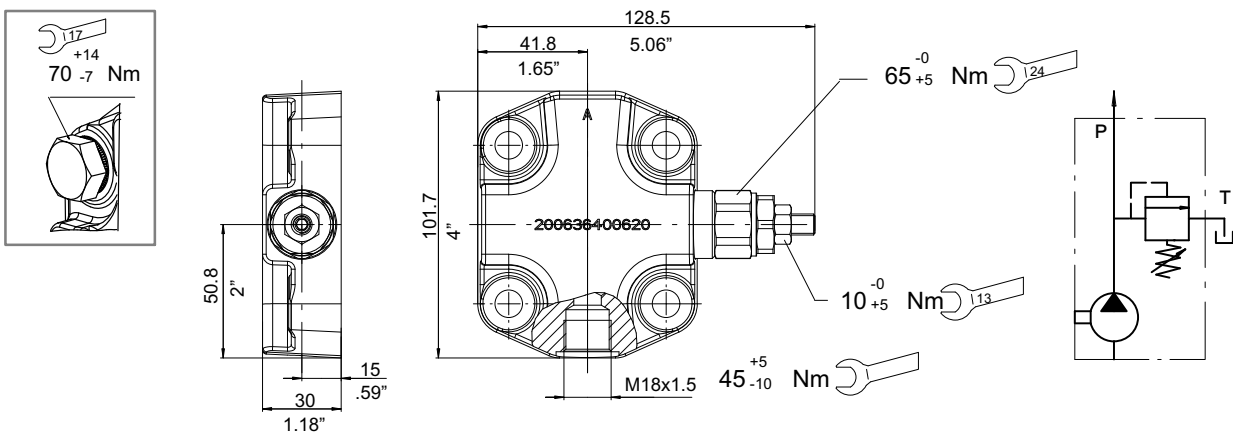

A	P	2	1	2	H	P	/	1	5	-	S	-	A	1	S	-	1	C	-	V	E	*	*	-	A		
---	---	---	---	---	---	---	---	---	---	---	---	---	---	---	---	---	---	---	---	---	---	---	---	---	---	--	--

Type	Ordering code
Cast iron back cover with relief valve. Return to external pump tank	VE**

** pressure set value (bar) - in example: VE06 = 60 bar

3.6.5 Pressure relief valve : **VM01C VI** and VE** pressure setting range

Direct acting
Balanced piston
Adjustable setting
Four setting ranges

Max. Pressure 350 bar ***
Max flow rate 60 l/min.
Temperature range -20/+100 °C
Weight: 0.155 Kg.

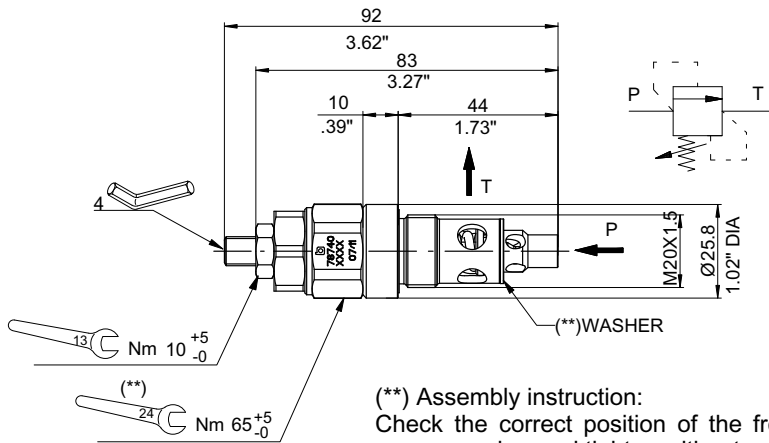

(**) Assembly instruction:
Check the correct position of the front copper washer and tighten with a torque wrench at the indicated value

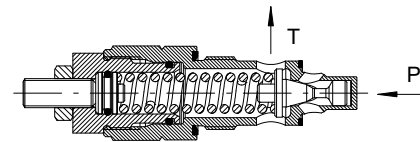

The valve can be sealed against tampering

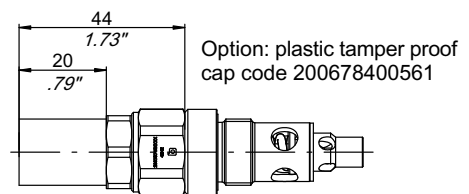

Pressure viscosity characteristic 46 cSt at 40°C

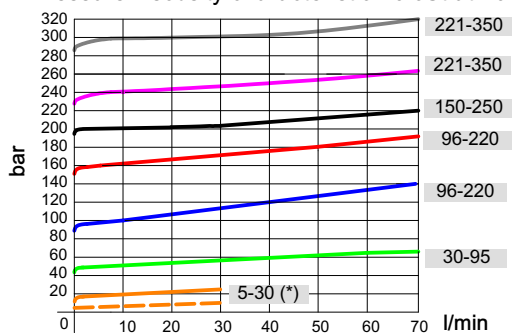

(*) see performances trace/minimum pressure setting (---)

The purpose of a relief valve is to keep the maximum system pressure at a safe level. When the external gear pump is supplied with pressure relief valves, the correct calibration is provided by Bucher Hydraulics S.p.A. and there are no reasons to change this value. When ordering, state in full the sheath part number, and, if the valve is to be supplied with sheath already fitted, the relief pressure setting required.

*** Maximum admitted pressure value: referred to valve only. For max admitted values see pump limits.

Performances	
Max. flow	60 l/min.
Pressure setting flow	5 l/min
Max internal leakage	200 cm ³ /min at 80% of nominal pressure setting
Oil viscosity	12 to 400 cSt
Oil temperature	-20 to 100 °C
Recommended filtration	21/19/16 (10 NAS 1638)
Marking info:	Printed code and date

Spring	Spring code	Setting range	Standard setting	Q max (l/min)	Type	Relief valve only code
00	-	Plugged	Without valve	-	00VC00	200978400140
02	200662403160	5 - 30 bar	20 bar	30 (*)	02VM01C	200787403600
05	200662403080	30 - 95 bar	50 bar	60	05VM01C	200787403480
12	200662403050	96 - 220 bar	120 bar	60	12VM01C	200787403420
15	200662403070	150 - 250 bar	150 bar	60	15VM01C	200787403470
23	200662403060	221 - 350 bar	230 bar	60	23VM01C	200787403430

Pressure setting valve referred to 5 l/min

4 Multiple gear pumps

The multiple external gear pumps standard version includes an intermediate cover without shaft seal between the pumps.

If needed, it is possible to order a customised version with intermediate seal, see section 4.3 (4.5 for tandem pumps AP212HP+AP212 aluminium body).

4.1 Drive torque

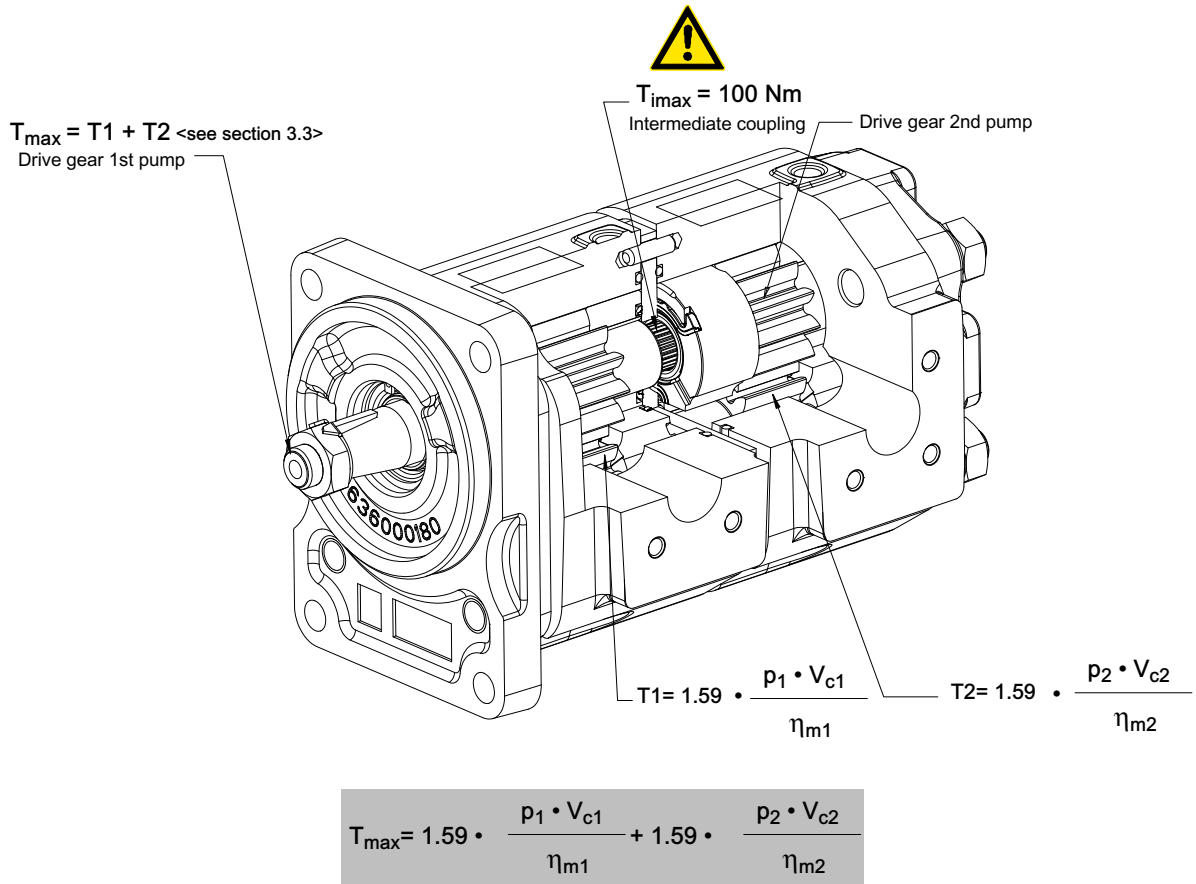

Example: AP212HP/19 + AP212HP/15

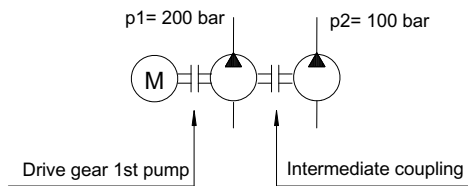

$$T_{\max} = 1.59 \cdot \frac{19.2 \cdot 200}{90} + 1.59 \cdot \frac{15.1 \cdot 100}{90} = 68 + 26.7 = 94.7 \text{ Nm}$$

$$T_{\max} = 94.7 \leq 130 \text{ Nm}$$

(taper 1:8)

$$T_2 = 26.7 \leq T_{\max} 100 \text{ Nm}$$

4.2 Tandem pumps dimensions AP212HP+AP212HP (standard version without shaft seal between the pumps)

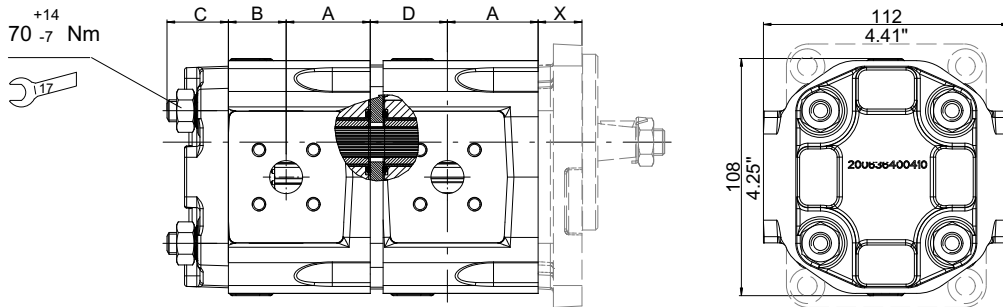

Pump size	A		B		D (B + 5.8)		C*	
	mm	inches	mm	inches	mm	inches	mm	inches
AP212HP/15	38.3	1.51	26.3	1.04	32.1	1.26	28	1.10
AP212HP/19	41.3	1.63	29.3	1.15	35.1	1.38		
AP212HP/22	43.55	1.71	31.55	1.24	37.35	1.47		
AP212HP/26	46.55	1.83	34.55	1.36	40.35	1.59		
AP212HP/29	48.55	1.91	36.55	1.44	42.35	1.67		
AP212HP/33	51.55	2.03	39.55	1.56	45.35	1.79		

C*: dimensions with standard cast iron back cover with tie rod + nut .
For other back covers dimension see section 3.6

4.2.1 Standard versions, dimensions example

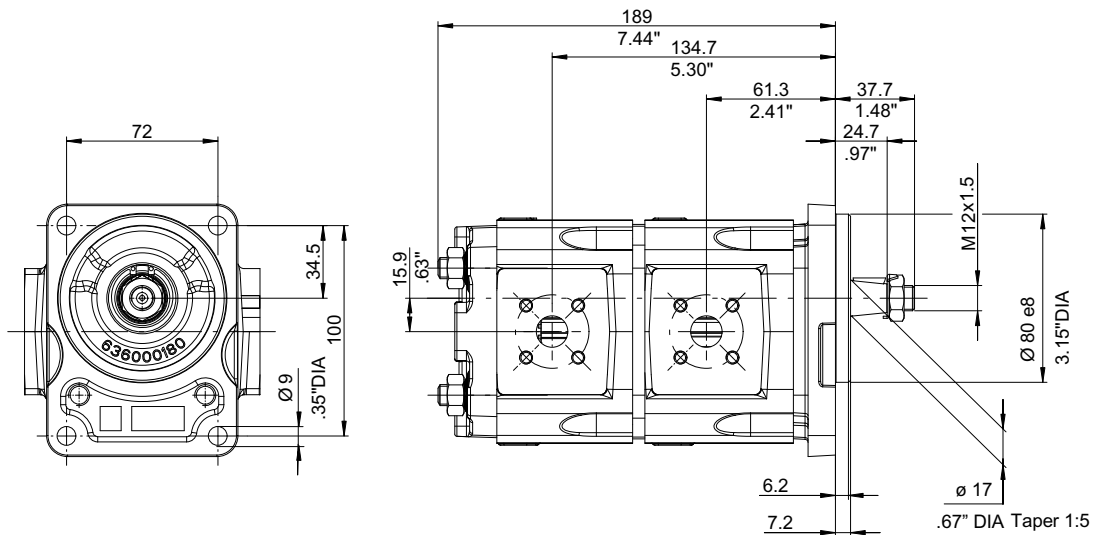

Example

Total length: 189 mm = 20 + 41.3 + 35.1 + 38.3 + 26.3 + 28 (X + A + D + A + B + C)

Port position: 134.7 mm = 20 + 41.3 + 35.1 + 38.3 (X + A + D + A)

61.3 mm = 20 + 41.3 (X + A)

4.3 Tandem pumps dimensions AP212HP+AP212HP (standard version with shaft seal between the pumps)

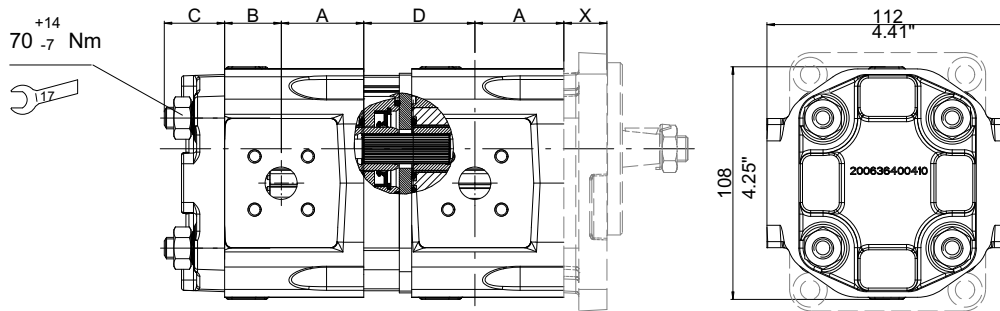

Pump size	A		B		D (B + 5.8)		C*	
	mm	inches	mm	inches	mm	inches	mm	inches
AP212HP/15	38.3	1.51	26.3	1.04	48.6	1.91	28	1.10
AP212HP/19	41.3	1.63	29.3	1.15	51.6	2.03		
AP212HP/22	43.55	1.71	31.55	1.24	53.85	2.12		
AP212HP/26	46.55	1.83	34.55	1.36	56.85	2.24		
AP212HP/29	48.55	1.91	36.55	1.44	58.85	2.32		
AP212HP/33	51.55	2.03	39.55	1.56	61.85	2.44		

C*: dimensions with standard cast iron back cover with tie rod + nut .
For other back covers dimension see section 3.6

4.3.1 Standard versions, dimensions example

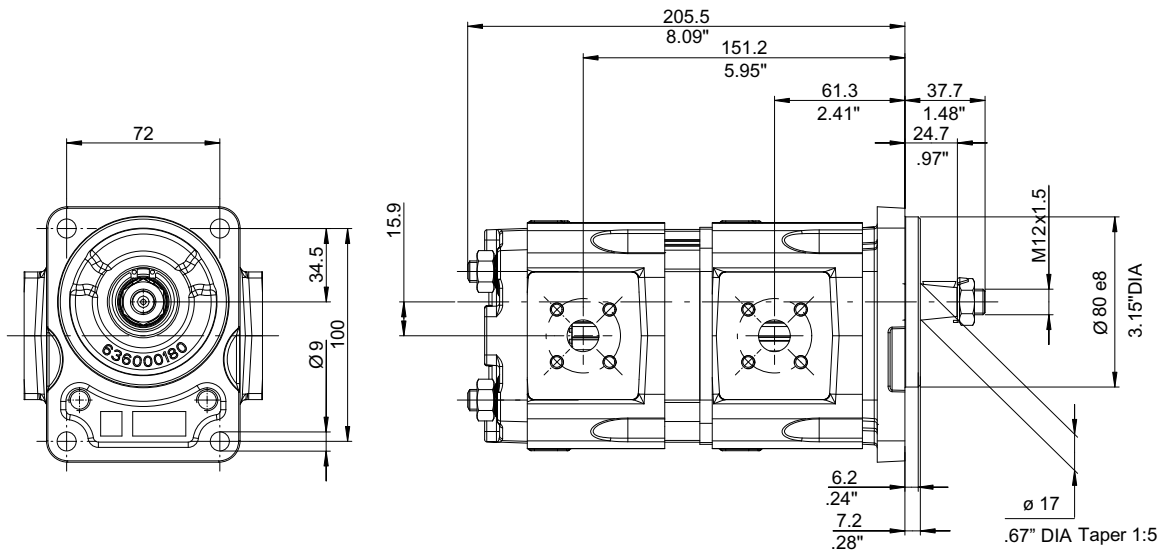

Example

Total length: $205.5 \text{ mm} = 20 + 41.3 + 51.6 + 38.3 + 26.3 + 28$ (X + A + D + A + B + C)

Port position: $151.2 \text{ mm} = 20 + 41.3 + 51.6 + 38.3$ (X + A + D + A)

$61.3 \text{ mm} = 20 + 41.3$ (X + A)

4.4 Tandem pumps dimensions AP212HP+AP212 aluminium body (standard version without shaft seal between the pumps)

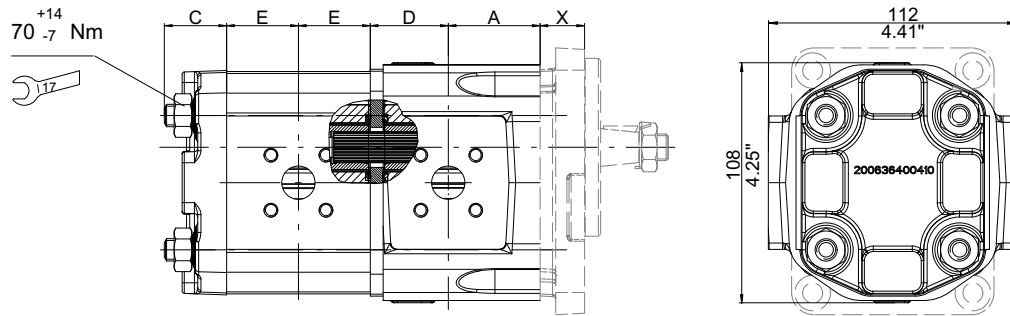

Pump size	A		D (B + 5.8)		C*	
	mm	inches	mm	inches	mm	inches
AP212HP/15	38.3	1.51	32.1	1.26	28	1.10
AP212HP/19	41.3	1.63	35.1	1.38		
AP212HP/22	43.55	1.71	37.35	1.47		
AP212HP/26	46.55	1.83	40.35	1.59		
AP212HP/29	48.55	1.91	42.35	1.67		
AP212HP/33	51.55	2.03	45.35	1.79		

Pump size AP212	E	
	mm	inches
AP212/4.5	24.3	0.96
AP212/6.5	25.8	1.02
AP212/8.5	27.3	1.08
AP212/11	29.3	1.54
AP212/15	32.3	1.27
AP212/19	35.3	1.39
AP212/22	37.6	1.48
AP212/26	40.6	1.60

C*: dimensions with standard back cover in cast iron .
For other back covers dimension see section 3.6

4.4.1 Standard versions, dimensions example

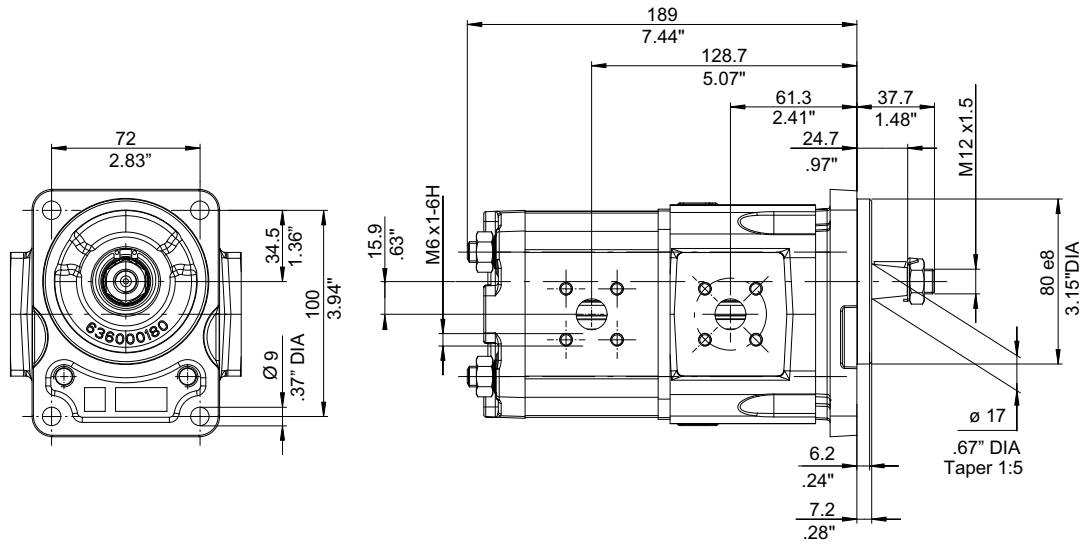

Example

Total length: 189 mm = 20 + 41.3 + 35.1 + 32.3 + 32.3 + 28 (X + A + D + A + A + C)

Port position: 128.7 mm = 20 + 41.3 + 35.1 + 32.3 (X + A + D + A)

61.3 mm = 20 + 41.3 (X + A)

4.5 Tandem pumps dimensions AP212HP+AP212 aluminium body (standard version with shaft seal between the pumps)

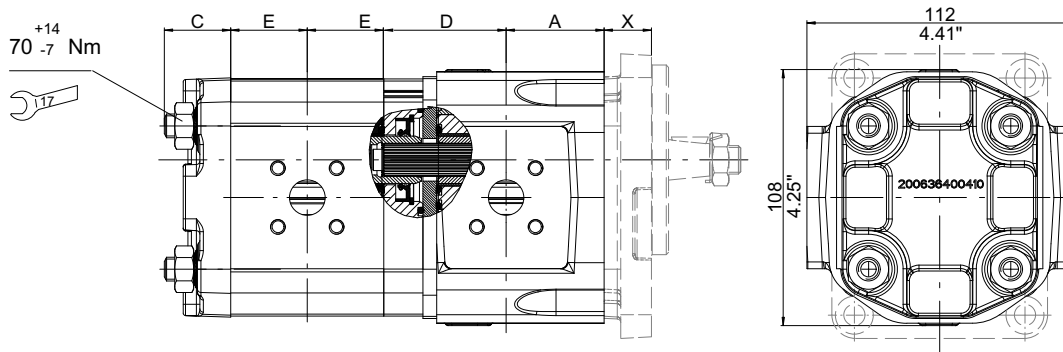

Pump size	A		D (B + 22.3)		C*	
	mm	inches	mm	inches	mm	inches
AP212HP/15	38.3	1.51	48.6	1.91	28	1.10
AP212HP/19	41.3	1.63	51.6	2.03		
AP212HP/22	43.55	1.71	53.85	2.12		
AP212HP/26	46.55	1.83	56.85	2.24		
AP212HP/29	48.55	1.91	58.85	2.32		
AP212HP/33	51.55	2.03	61.85	2.44		

Pump size AP212	E	
	mm	inches
AP212/4.5	24.3	0.96
AP212/6.5	25.8	1.02
AP212/8.5	27.3	1.08
AP212/11	29.3	1.54
AP212/15	32.3	1.27
AP212/19	35.3	1.39
AP212/22	37.6	1.48
AP212/26	40.6	1.60

C*: dimensions with standard back cover in cast iron .
For other back covers dimension see section 3.6

4.5.1 Standard versions, dimensions example

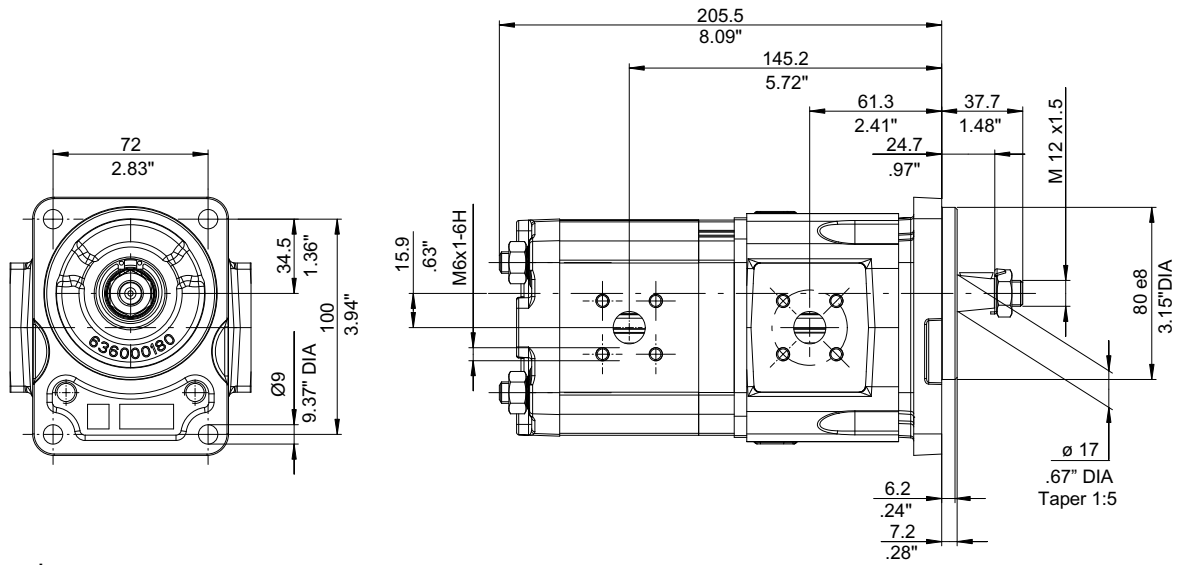

Example

Total length: 205.5 mm = 20 + 41.3 + 51.6 + 32.3 + 32.3 + 28 (X + A + D + A + A + C)

Port position: 145.2 mm = 20 + 41.3 + 51.6 + 32.3 (X + A + D + A)

61.3 mm = 20 + 41.3 (X + A)

4.6 How to order tandem pumps (with or without shaft seal between the pumps)

1st PUMP										2nd PUMP										1st BODY		2nd BODY																		
1	2				3	4	2				3	4	5	6	7	8	9	10	9	10	11		12																	
A	P	2	1	2	H	P	/	1	9	L	N	-	2	1	2	H	P	/	1	5	L	N	-	S	-	A	0	S	-	8	A	-	8	A	-	V	E	1	6	P

1 Function

AP= single gear pump - unidirectional
APR = single gear pump - reversible

2 Series

212HP

3 Displacement

15= 15.1 cm³/rev
19= 19.2 cm³/rev
22= 22.2 cm³/rev
26= 26.2 cm³/rev
29= 28.9 cm³/rev
33= 33 cm³/rev

4 Version

Omitted if 12 teeth standard
LN= 12 teeth Low Noise version

5 Rotation

S = left-hand rotation
D = Right-hand rotation
Omitted if reversible version

6 Shaft end code

see section 3.3

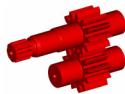

7 Shaft seal material type code

see section 3.4.1



8 Front cover series/material with/without bearing code

see section 3.4.2 and 3.4.3



9 Type of ports code

see section 3.5



10 Inlet/outlet port size code combination

see section 3.5



11 Back cover type / Valve setting value

see section 3.6



12 For Tandem pumps with or without shaft seal between the pumps

Omitted if without shaft seal between the pumps (standard versions)
P= with shaft seal between the pumps (special versions)

5 Circuits/valves option

For Technical features and availability please contact our Sales Department

5.1 Load sensing circuits

5.1.1 Load sensing valve rear cover assembly position

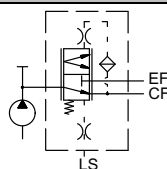
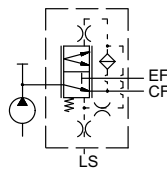
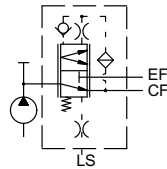
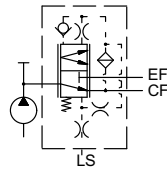
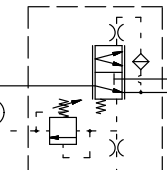
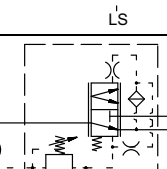
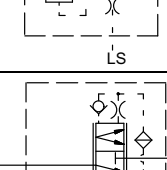
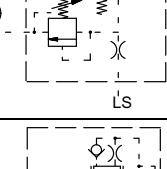
Hydraulic scheme	Family	Description	Code
	STATIC	Static LS signal	LSB01
	DYNAMIC	Dynamic LS signal	LDB01
	STATIC	Static LS signal + check valve on CF line	LSB02
	DYNAMIC	Dynamic LS signal + check valve on CF line	LDB02
	STATIC	Static LS signal + relief valve on LS signal	LSB03
	DYNAMIC	Dynamic LS signal + relief valve on LS signal	LDB03
	STATIC	Static LS signal + check valve on CF line and relief valve on LS signal	LSB04
	DYNAMIC	Dynamic LS signal + check valve on CF line and relief valve on LS signal	LDB04

5.1.2 Load sensing valve lateral assembly position

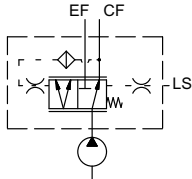
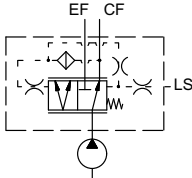
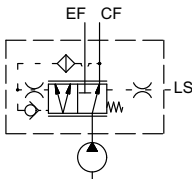
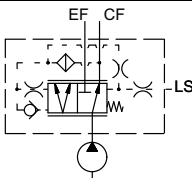
Hydraulic scheme	Family	Description	Code
	STATIC	Static LS signal	LSS01
	DYNAMIC	Dynamic LS signal	LDS01
	STATIC	Static LS signal + check valve on CF line	LSS02
	DYNAMIC	Dynamic LS signal + check valve on CF line	LDB02

6 Rotation changing instructions

For the AP212HP pumps with unidirectional left (S) or right (D) rotation (not for 287S-SAEB pump) it is possible to change the rotation direction of the entire range without having to replace any component. To ensure a good technical result, we recommended in any case that such inversion should be carried out at our factory.

Following we represented a procedure for the pump rotation inversion, here in example a clockwise rotation pump (D). To obtain a counter-clockwise rotation (S) see the following pictures/instructions.

At start up increase pressure slowly where possible.

Picture -1-

Initial configuration "Right" (D)

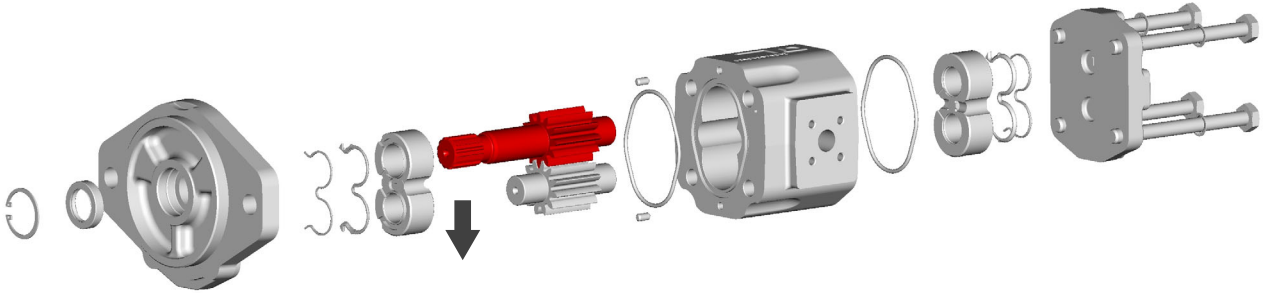
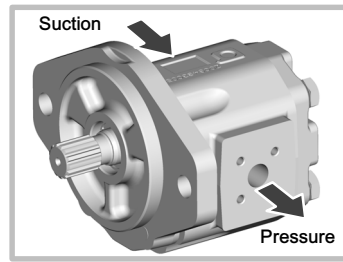

Picture -2-

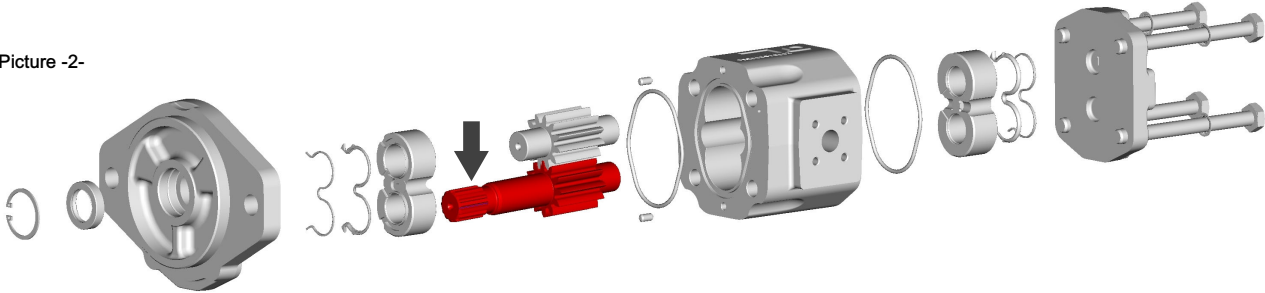

Picture -3-

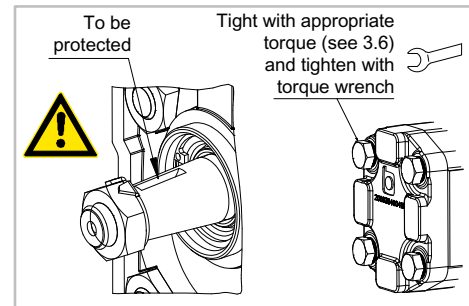
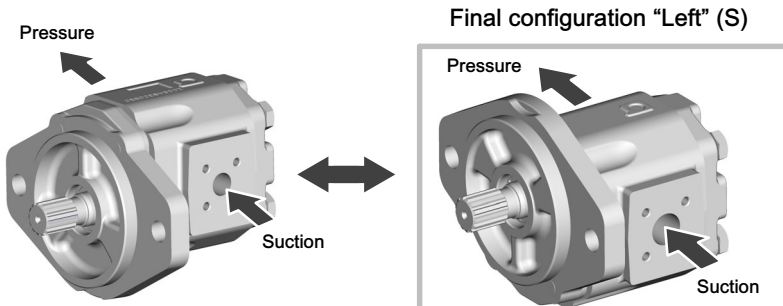
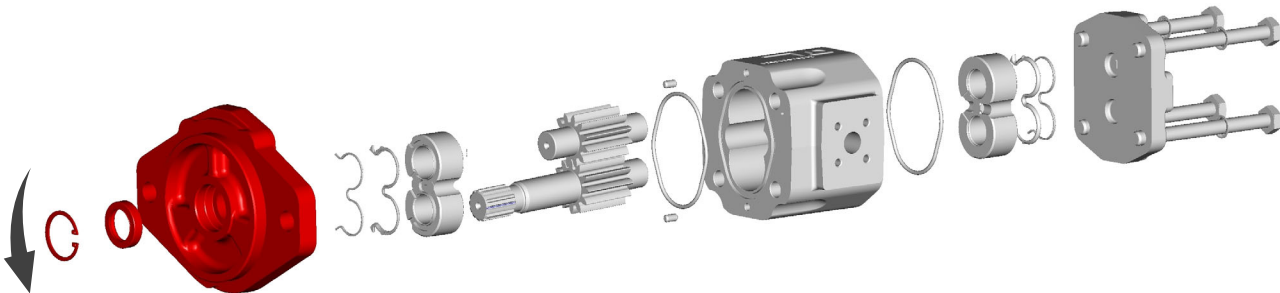

7 Pumps seal kit NBR + HNBR standard type

The seal Kit code includes:
OR and shaft seal

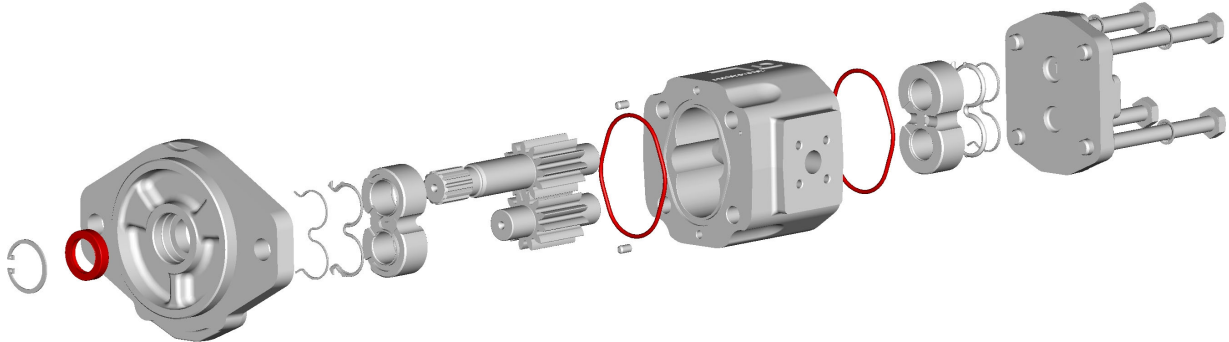

Type	Code
AP/APR212HP	200974001570

Minimum kit order quantity is requested: please contact our Sales Center

8 Product identification plate

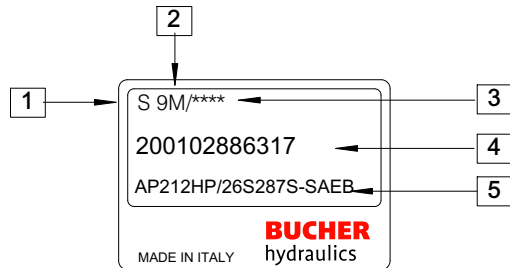

- 1 : Rotation
(D= Clockwise rotation - S= Counterclockwise rotation)
- 2 : Manufacturing year and month
- 3 : Progressive identification no. (optional)
- 4 : Bucher Hydraulics S.p.A. product code
- 5 : Description

Manufacturing month	Manufacturing year						
	2017	2018	2019	2020	2021	2022	2023
January	7A	8M	9M	0M	1M	2M	3M
February	7B	8N	9N	0N	1N	2N	3N
March	7C	8P	9P	0P	1P	2P	3P
April	7D	8Q	9Q	0Q	1Q	2Q	3Q
May	7E	8R	9R	0R	1R	2R	3R
June	7F	8S	9S	0S	1S	2S	3S
July	7G	8T	9T	0T	1T	2T	3T
August	7H	8U	9U	0U	1U	2U	3U
September	7I	8V	9V	0V	1V	2V	3V
October	7J	8Z	9Z	0Z	1Z	2Z	3Z
November	7K	8X	9X	0X	1X	2X	3X
December	7L	8Y	9Y	0Y	1Y	2Y	3Y

9 Application form

Date:			
Contact:			
Customer:			
Location:			
Overall quantity per year:			
Minimum batch size:			
Delivery time requested:	Feasibility:	Prototypes:	Series:
Target price:			
Type of application:			

External gear pump general data					
Rotation	S	D	R	Speed range	
Displacement: Single pump (cm ³ /rev)				Continuous work pressure (bar)	1st 2nd 3rd
Double pump (cm ³ /rev)	1st	2nd		Peak work pressure (bar)	1st 2nd 3rd
Multiple pump (cm ³ /rev)	1st	2nd	3rd	Oil type	
Drive shaft				Oil temperature (°C)	min max
Port type				Oil viscosity (cSt)	min max
Front cover type				Suction line pressure	
Bearing support				Voltage	
Front cover material				Drain case pressure	
Intermediate cover (with or without shaft seal)	with	without		Radial load (N)	
Back cover type/circuit				Axial load (N)	
Back cover material	aluminium	cast iron		Working hours per year	
Valves				Cycles per year	

Additional notes:

info.it@bucherhydraulics.com

www.bucherhydraulics.com

© 2020 by Bucher Hydraulics S.p.A, I-42124 Reggio Emilia

All rights reserved.

Data is provided for the purpose of product description only, and must not be construed as warranted characteristics in the legal sense. The information does not relieve users from the duty of conducting their own evaluations and tests. Because the products are subject to continual improvement, we reserve the right to amend the product specifications contained in this catalogue.

Classification: 410.110.000