

AP312HP Gear Pumps

Single and multiple cast iron gear pumps



OIL SOLUTIONS

PO Box 38
Strathfieldsaye, VIC, 3551
1800 OIL SOL
1800 645 765

sales@oilsolutions.com.au

www.oilsolutions.com.au

"For All Your Hydraulic Needs"

Contents

Page

1	General information	3
1.1	External gear pumps components and construction / benefits	4
1.2	Technical data	5
1.3	Pressure	6
1.4	Suction	6
1.5	General precaution	6
1.6	Identifying the rotation direction	7
1.7	Formulas to determinate main gear pump operate parameters	8
2	Overview standard pump configurations	8
2.1	Standard components configuration	9
3	AP312HP Single pump customised versions	26
3.1	Single pump customised versions order example	27
3.2	Shaft end code	28
3.3	Front cover/mounting flange	30
3.4	Single pump dimensions	35
4	Multiple gear pumps	37
4.1	Multiple gear pumps: AP312HP+AP312HP standard cast iron versions	37
4.2	Multiple gear pumps: AP312HP+AP212HP standard cast iron versions	40
4.3	Multiple gear pumps: AP312HP+AP212 aluminium version	44
4.4	Multiple gear pumps: AP312HP+AP312HP+AP212HP cast iron versions	48
4.5	Multiple gear pumps: AP312HP+AP312HP+AP212 aluminium version	52
5	Product identification plate	56
6	Application form	57

1 General information

The product range of Bucher Hydraulics SpA includes single pumps 05-100-212-212HP-250HP-312HP (corresponding with the common group denominations: 05-1-2-2.5-3) and several combinations of double pumps, multiple pumps, that can be assembled together according to versions of displacement, flanging, and auxiliary valves.

Bucher Hydraulics SpA has supplied a wide range of external gear pumps and motors to industrial and mobile applications since many years.

Bucher's external gear pumps are widely used in modern hydraulic system to obtain high performances, long life service and low purchase and maintenance costs.

Thanks to the positive field experiences recorded on the group 2 (AP212HP) and group 2.5 (AP250HP) cast iron pump and motor series, Bucher Hydraulics has completed its product range introducing the new AP312HP cast iron pump group 3. The new pump has been developed with

modern and robust design concepts.

Strong "2 pieces" structure, big shafts diameter as well as high quality materials, allows to the AP312HP to reach very high quality and performance levels, in order to fulfill the most innovative types of machines and applications.

Bucher designed this new pump with support bearings mounted in the cast iron body and covers.

Tandem and multiple pumps are also available to fulfill all applications such as telehandler, excavator, crusher, wheel loader, harvester and earth drilling machine.

Bucher Hydraulics has so achieved this state of the art by constantly improving its design, control and manufacturing techniques aligned with the latest technological developments, while simultaneously enhancing its Quality System ensuring that every single product offers the same high standards.

Main applications and benefits

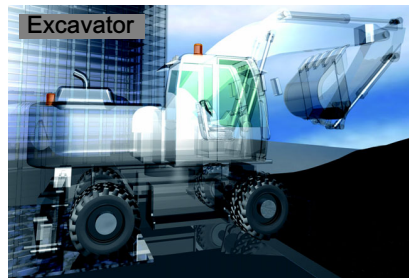

- Robust design in compact dimensions
- Teeth design optimisation oriented to reduce pressure pulsation
- Reduced noise and vibration
- Reduced number of components - reduced weight
- Double shaft seals - More shaft protection and long life without external leakage
- HNBR seals
- Wide fluid temperature range admitted
- High volumetric and mechanical efficiencies
- Single or multistage possible configurations
- Strong splined shaft multistage connections
- AP212 aluminium / AP212HP cast iron rear interface
- Bucher validation method: long life expectancy

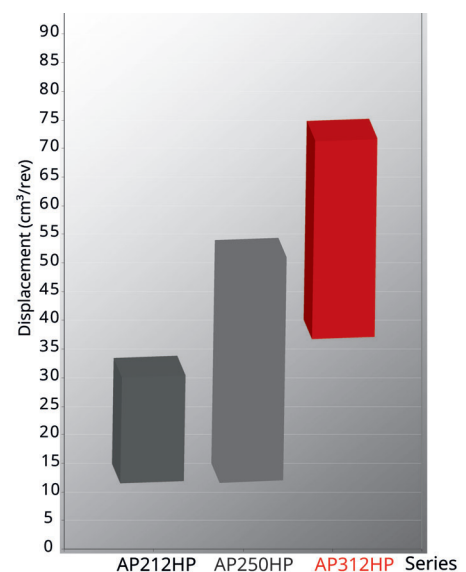

1.1 External gear pumps components and construction / benefits

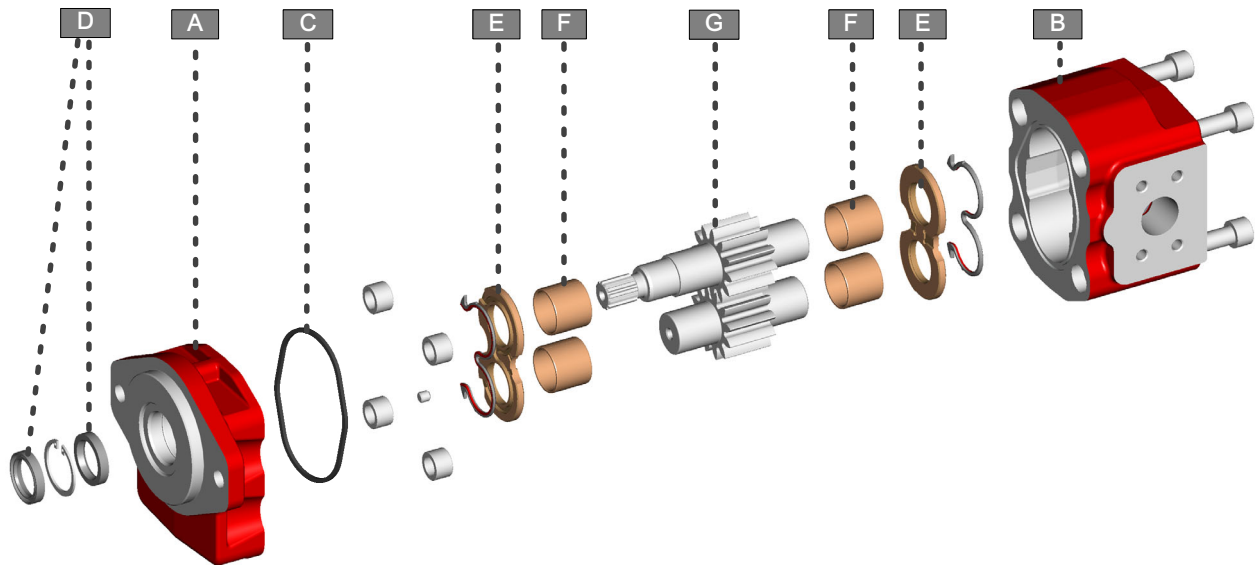

A
Cast iron front cover: the standard front-cover design can be fitted to four different pump interfaces

B
Cast iron main pump body: wide range of displacements obtainable with two different basic bodies both with back cover integrated. Rear ports on request.

C
HNBR seal material instead of NBR

D
Double HNBR shaft seals

E
Strong bimetallic pressure-balance plate instead of aluminium. Balancing area and intermediate notches optimised

F
Large-diameter bearings, fitted both in front cover and body

G
Large number of teeth, tooth profile optimised, larger shaft diameter

BENEFITS

- A B** Flexibility/smaller number of components
- A B D** Reduced risk of external leakage
- A B E** High efficiencies/pressure limits
- A B E** Long life expectancy
- C D** Wider temperature range
- E G** Lower pressure ripple
- E G** Noise/vibration reduction
- E F G** Higher load capacity and transmissible torque
- E F G** Low friction and high mechanical efficiency
- E F G** Higher max. pressure limit

The front mounting flange and the body/backcover are made of high-strength cast iron to give thermal stability, resistance to contamination and the strength necessary for persistently high levels of performance and life, needed in demanding heavy duty applications. Body/back cover integrated, larger shaft diameter, large-diameter bearing and bronze trust plate have been optimized to provide heavy

duty, high pressure limits, high efficiencies and long life expectancy.

Noise and vibration reduction due to the large number of teeth.

The bearings are located in the front mounting flange, in the body/back cover and, for multiple pumps, in the body pumps.

1.2 Technical data

Features	
Operating fluid temperature range (mineral oil): HNBR	-20 / +90 °C (peak: -30 / +110 °C)
Recommended fluids	hydraulic mineral oil-based
Viscosity range: Recommended Permitted Permitted for starting	20-120 mm ² /s (cSt) up to 700 mm ² /s (cSt) 2000 mm ² /s (cSt)
Cleanliness: recommended for operating pressure > 170 bar recommended for operating pressure < 170 bar	21/18/15 ISO 4406 22/19/16 ISO 4406
Standard seals material (valves not included)	HNBR standard

Extreme working limit values can not be combined

Type	Displacement		Pressure				Min speed rpm	Max speed** rpm
	cm ³ /rev	Cu.In.P.R.	P1		P3			
			bar	P.S.I.	bar	P.S.I.		
40	40.2	2.45	300	4300	320	4600	500	3000
45	45	2.75	300	4300	320	4600	500	3000
54	54.4	3.32	290	4100	310	4400	500	3000
63	63.1	3.85	280	4000	300	4300	500	2500
75	75.3	4.60	240	3400	260	3700	500	2000

** : The max admitted speed is referred to single pump/single inlet configuration. In case of multiple pumps with common suction line, a speed reduction must be considered.



IMPORTANT!: The pressure values are referred to unidirectional pumps, single versions only.

Please consult Bucher Hydraulics if even one of the operating limits indicated in the table (temperature, pressure, rpm) is exceeded, as well as in the case of two or more maximum values at the same time, or for applications with particularly heavy-duty cycles

1.3 Pressure

Pressure levels:

P1 = continuous pressure

P3 = peak pressure

The recommended oil speed in the pressure pipes is:

$v = 2$ to 5 m/s

1.4 Suction

The absolute suction pressure must be $P_{in} \geq 0.75$ bar (11 PSI); therefore, the following must be avoided:

- large height differences between pump and tank
- long stretches of piping
- special features such as:
 - bends
 - reductions in diameter
 - quick couplings
 - etc.

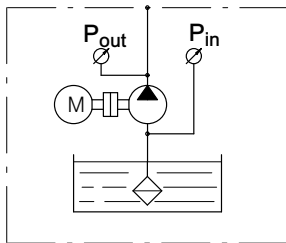

(Example 1)

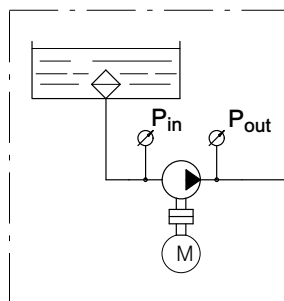

(Example 2)

1.5 General precaution

In addition to the recommendations regarding fluids, filtration, coupling, etc., we suggest the following:

- Always check the rotation direction of the pump's drive shaft; it must be compatible with the rotation direction of the pump itself.
- Be particularly careful in cleaning and make sure, when connecting the suction and pressure piping, that no chips, rag threads, teflon tape, etc. get into the pump circulation system.
- Check the tightness of the suction and pressure fittings, the correct positioning of the O-Ring, and make sure there is no dirt between the flange and the pump body.
- The first pump start-up can be facilitated by manually filling the suction piping and the pump itself with oil. To facilitate air bleeding, start the pump with the circuit not pressurised.

1.5.1 Hydraulic fluid

The main function of the fluid used in hydraulic systems is to transfer energy but it performs also other important functions: protect the components from corrosion, lubricate the pump moving parts, remove particles and heat from the system.

In order to ensure proper operation and long life of the system it is important to choose the correct hydraulic fluid with proper additives.

Bucher Hydraulics recommends to use a mineral based oil responding to ISO 6743/4 requirements, only.

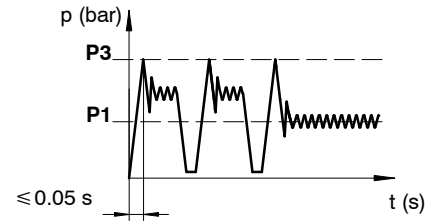

It is also advisable to choose a filter of a suitable size to minimise any pressure drop and to take measures to prevent gradual clogging over time.

- To ensure the best heat distribution inside the tank, make sure the return pipe is not too close to the pump's suction piping. The pipings themselves should be below oil tank level to prevent the formation of foam.
- Do not subject the pumps to operating conditions different from those indicated on section 1.2 ; for extreme operations, always contact our Sales Department.
- In the event of pump painting, do not use solvents or paints that are incompatible with the material of the seals. Do not bake paint with excessively high temperatures. Do not paint over the product identification plate.

The system should be operated only with hydraulic oil containing anti-foaming and antioxidant additives. Before using other types of fluid, please contact our Sales Dept, since they can cause serious damage to the directional valve components and jeopardize the correct function of the system.

Never use fluids different from those indicated in section 1.2 and do not use fluids incompatible with the pump seals (i.e. HNBR)

1.5.2 Filtration

In order to ensure proper operation and long life of the pump components it is extremely important to provide a proper and effective filtration of the hydraulic fluid.

It is advisable to follow filter manufacturers instruction and recommendations.

The fineness of the filter should be selected in order to guarantee that a contamination levels indicated on section 1.2. When the high reliability of the system is an important requirement, a pressure filter must be used. In these cases it is also advisable to use a pressure filter with by-pass and indicator.

The size of the return filters must suit the maximum return

flow whereas the size of the pressure filters must suit the maximum pump flow.

It is advisable to fit filters with pressure gauge or dirt indicator in order to make it possible to verify the filter condition. Particular attention has to be paid to the cleaning of the machine hydraulic circuit and its components before the first run-in, since the presence of foreign materials could cause damages even if a proper filtration is provided.

In order to obtain the best performance of the system we recommend to strictly follow the conditions advised here above, failing which warranty shall be void.

1.5.3 Directives and standards

Atex



Attention: The equipment and protective systems of this catalogue ARE NOT intended for use in potentially explosive atmospheres. Ref: Directive 99/92/EC and Directive 2014/34/EU.

- ISO 9001: 2015 / ISO 14001:2015

Bucher Hydraulics S.p.A. is certified for research, development and production of directional control valves, gear pumps and motors, power units, electro pumps, cartridge valves and integrated manifolds for hydraulic applications.

1.6 Identifying the rotation direction

The rotation direction of a gear pump is identified by looking at the pump from the front and with the drive gear turned upwards (see figures below).

Pumps with clockwise rotation (D) have a drive gear which turns clockwise, with the suction port on the left and the pressure port on the right.

Pumps with counterclockwise rotation (S) have a drive gear which turns counterclockwise, with the suction port on the

right and the pressure port on the left. The figure also shows the pressure flow inside the pumps as the oil is transferred from the suction port to the pressure port.

Pumps with a unidirectional rotation (D or S) have the denomination AP.

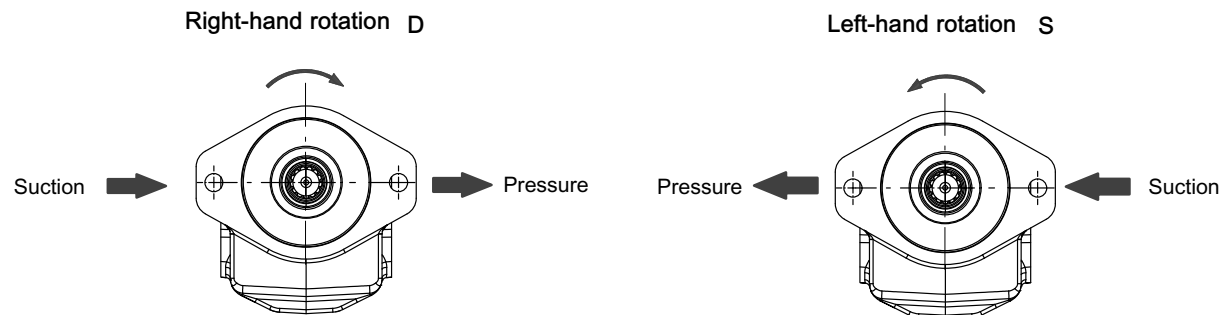

1.7 Formulas to determinate main gear pump operate parameters

The following parameters are defined:

V_c = (cm³/rev) pump displacement;

n = (rev/min) no. of rpms of the drive shaft;

Q = (l/min) flow rate;

p = (bar) operating pressure;

T = (Nm) drive torque;

N = (kW) Absorbed power;

η_v = (%) volumetric efficiency;

η_m = (%) mechanical efficiency;

η_t = (%) total efficiency

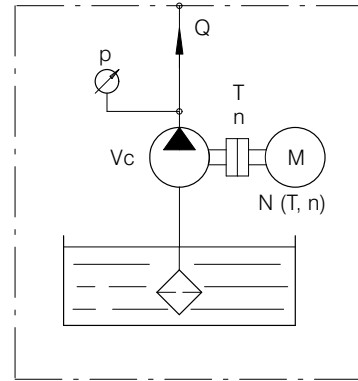

$$Q = \frac{V_c \cdot n}{100000} \cdot \eta_v \quad T = 1.59 \cdot \frac{p \cdot V_c}{\eta_m} \quad N = \frac{Q \cdot p}{6 \cdot \eta_t}$$

Example

AP312HP/40 $V_c = 40 \text{ cm}^3/\text{r}$ $n = 1500 \text{ r/min}$ $p = 200 \text{ bar}$ $\eta_v = 94\%$ $\eta_m = 90\%$ $\eta_t = 84.6\%$

$$Q = \frac{40 \cdot 1500}{100000} \cdot 94 = 56.4 \text{ l/min.}$$

$$T = 1.59 \cdot \frac{200 \cdot 40}{90} = 141.3 \text{ Nm}$$

$$N = \frac{56.4 \cdot 200}{6 \cdot 84.6} = 22.22 \text{ kW}$$

2 Overview standard pump configurations

This pumps configuration are considered as "standard".

13 teeth	S38B2S	S38B8G	S38B8S
15 teeth	S58B2S	S58B8G	S58B8S
Straight keyed $\varnothing 25.4 \text{ mm}$	C18B2S	C18B8G	C18B8S
Straight keyed $\varnothing 22.225 \text{ mm}$	C28B2S	C28B8G	C28B8S

14 teeth	S48C2S	S48C8G	S48C8S
----------	--------	--------	--------

14 teeth	S414C2S	S414C8G	S414C8S
15 teeth	S514C8G	S514C8G	S514C8S

Tapered 1:8	C81P2P	C81P8G	
-------------	--------	--------	--

Example

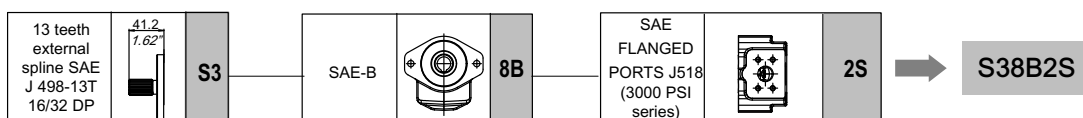

In the next pages, front, body/rear cover, and seals materials are listed for each pump series.

For ordering purposes, it is enough to outline the complete pump description (for example: AP312HP/40 S38B2S).

In case of a different configuration request (or a combination of different features, such as port threads, front flange materials, etc.), the description configurator shown in section 3.1 can be easily used.

2.1 Standard components configuration

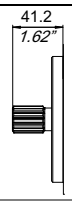
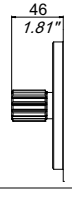
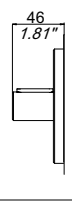
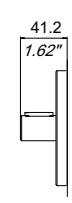
Drive shaft		
13 teeth external spline SAE J 498-13T 16/32 DP T _{max} = 270 Nm		S3
15 teeth external spline SAE J 498-15T 16/32 DP T _{max} = 460 Nm		S5
Straight keyed Ø 25.4 mm		C1
Straight keyed Ø 22.225 mm		C2

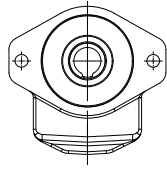
Cast iron flange		
SAE-B		8B

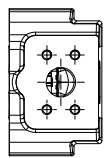
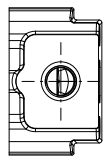
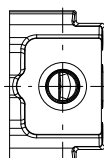
Cast iron body/back cover		
Port type		
SAE FLANGED PORTS J518 (3000 PSI series)		2S
BSP Ports		8G
SAE threaded ports UNF		8S

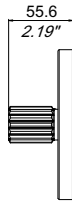
Drive shaft		
14 teeth external spline SAE J 498-14T 12/24 DP T _{max} = 950 Nm		S4

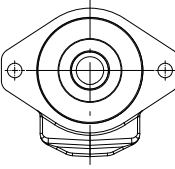
Cast iron flange		
SAE-C 2 fixing holes		8C

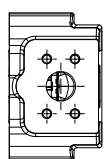
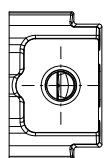
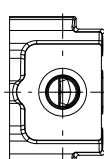
Cast iron body/back cover		
Port type		
SAE FLANGED PORTS J518 (3000 PSI series)		2S
BSP Ports		8G
SAE threaded ports UNF		8S

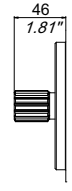
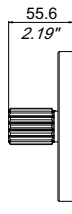
Drive shaft		
15 teeth external spline SAE J 498-15T 16/32 DP $T_{max} = 460 \text{ Nm}$		S51
14 teeth external spline SAE J 498-14T 12/24 DP $T_{max} = 950 \text{ Nm}$		S41

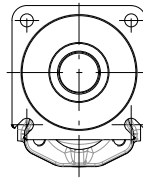

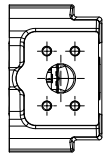
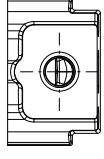
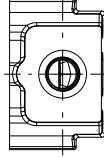
Cast iron flange		
SAE-C 4 fixing holes		4C
Flange 4C refers to standard applications without axial and radial loads. For applications requiring bearings, please contact our Sales Department.		

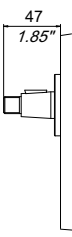
Cast iron body/back cover Port type		
SAE FLANGED PORTS J518 (3000 PSI series)		2S
BSP Ports		8G
SAE threaded ports UNF		8S

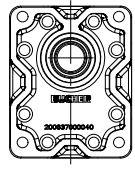
Drive shaft		
Tapered 1:8		C8

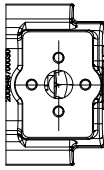
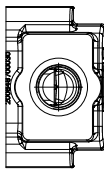
Cast iron flange		
European rectangular		1P

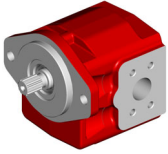
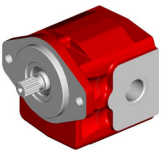
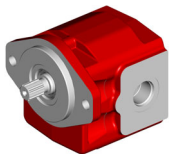
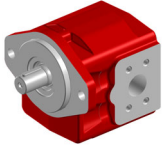
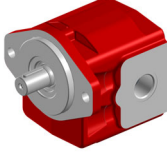
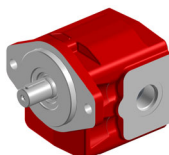
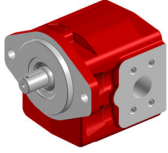
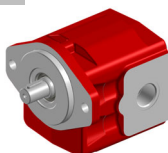
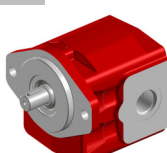
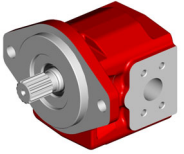
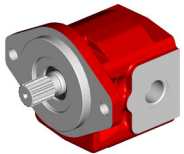
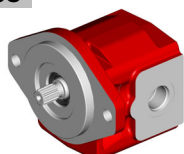
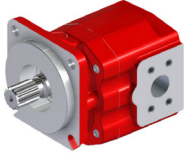
Cast iron body/back cover Port type		
European 4 bolts flanged		2P
BSP Ports		8G

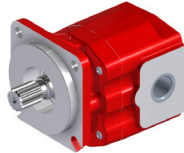
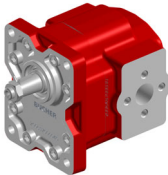
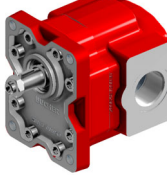
Serie	page	Serie	page	Serie	page
S38B2S-S58B2S 	12	S38B8G-S58B8G 	13	S38B8S-S58B8S 	14
C18B2S 	15	C18B8G 	16	C18B8S 	17
C28B2S 	15	C28B8G 	16	C28B8S 	17
S48C2S 	18	S48C8G 	19	S48C8S 	20
S414C2S - S514C8G 	21	S414C8G - S514C8G 	22	S414C8S - S514C8S 	23
C81P2P 	24	C81P8G 	25		

Unpainted pumps are Bucher Hydraulics standard; should a painted component be required, this feature must be specified in its purchase order.

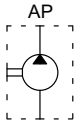

S38B2S
S58B2S

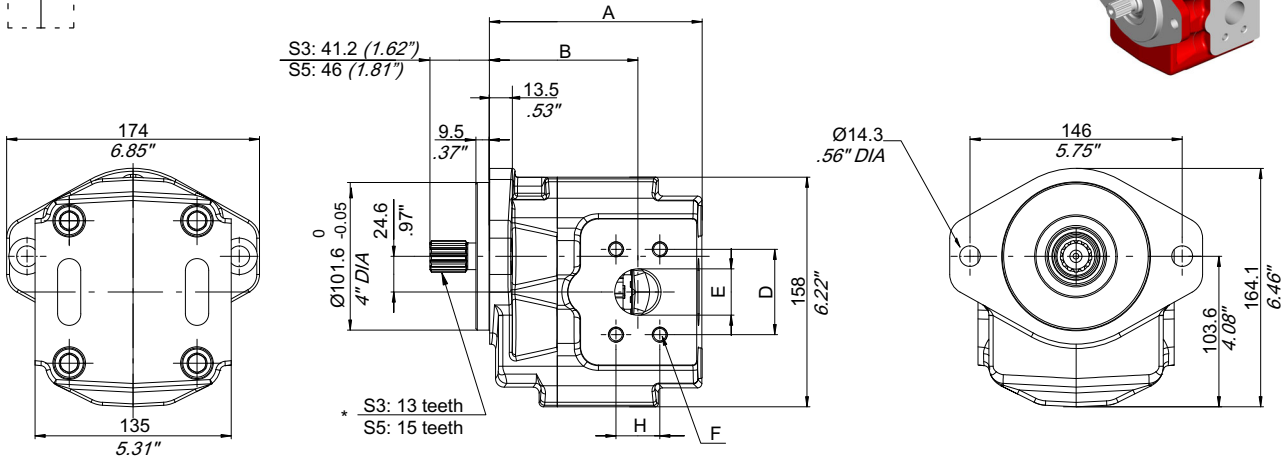
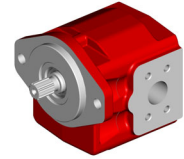

Type	A		B		Suction						Pressure															
	mm	inch	mm	inch	H		D		E		F	H		D		E		F								
40	132	5.20	87.8	3.46	30.17	1.19	58.72	2.31	31.8	1.25	M10x 1.5															
45	135	5.31	90.8	3.57	35.71	1.40	69.85	2.75	38.1	1.5	M12x 1.75	26.19	1.03	52.37	2.06	25.4	1	M10x 1.5								
54	140.8	5.54	96.6	3.80																						
63	146.2	5.76	102	4.02																						
75	153.8	6.06	109.6	4.31																30.17	1.19	58.72	2.31	31.8	1.25	

Pump description example:

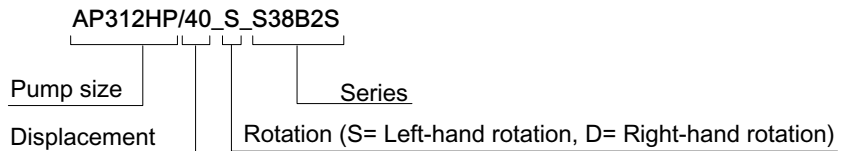

* For S3- S5 dimensions see 3.2

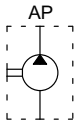

S38B8G
S58B8G

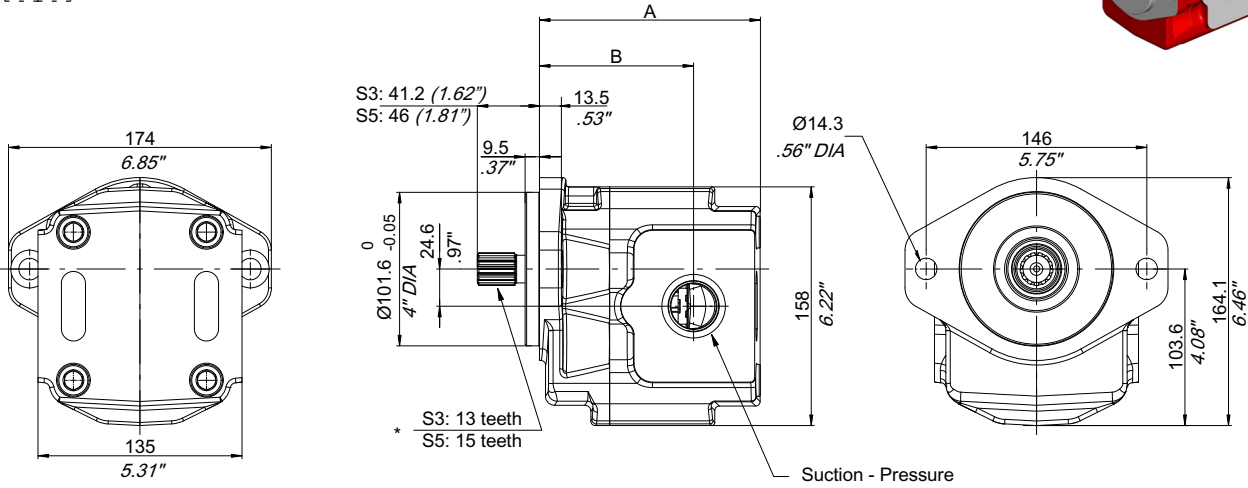
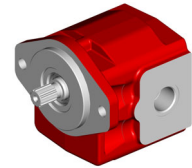

Type	A		B		Suction BSPP	Pressure BSPP
	mm	inch	mm	inch		
40	132	5.20	87.8	3.46	1 1/4" BSP	1" BSP
45	135	5.31	90.8	3.57		
54	140.8	5.54	96.6	3.80		
63	146.2	5.76	102	4.02		
75	153.8	6.06	109.6	4.31		

Pump description example:

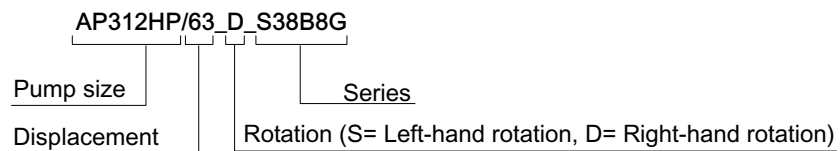

* For S3- S5 dimensions see 3.2

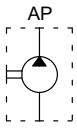

S38B8S
S58B8S

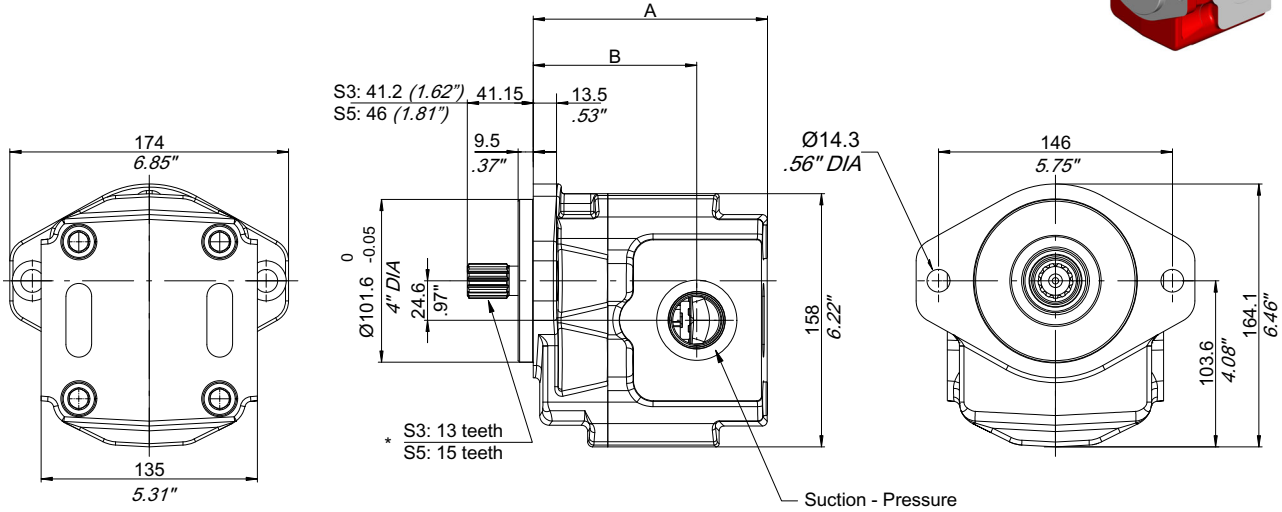
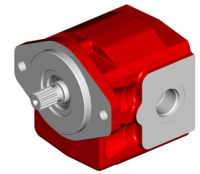

Type	A		B		Suction UNF	Pressure UNF
	mm	inch	mm	inch		
40	132	5.20	87.8	3.46	1 5/8" - 12 UNF-2B (SAE20)	1 5/16" - 12 UNF-2B (SAE16)
45	135	5.31	90.8	3.57		
54	140.8	5.54	96.6	3.80		
63	146.2	5.76	102	4.02		
75	153.8	6.06	109.6	4.31		

Pump description example:

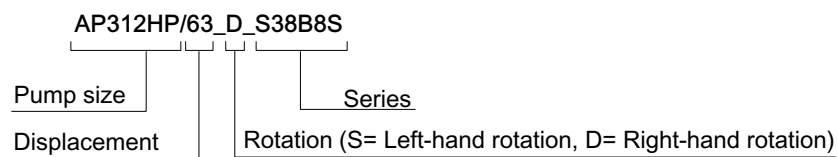

* For S3- S5 dimensions see 3.2

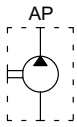

C18B2S
C28B2S

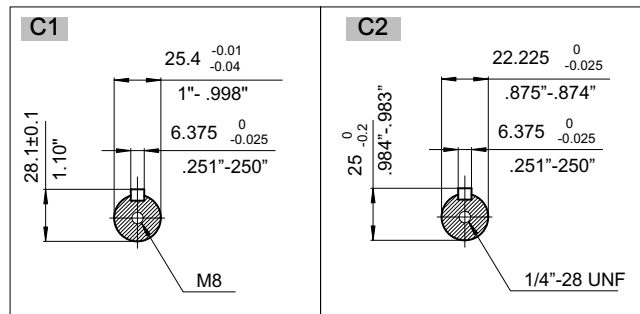
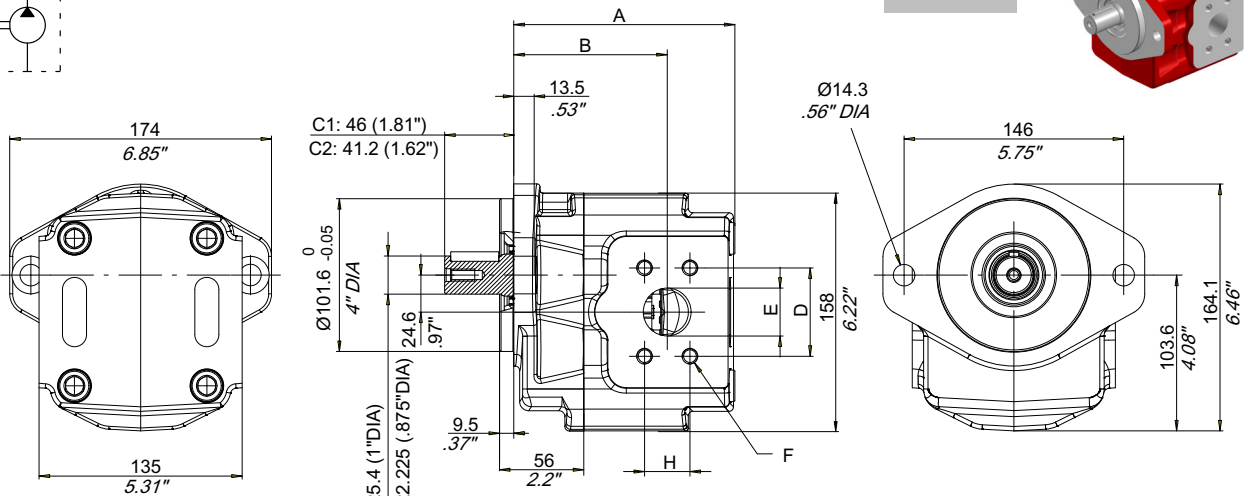
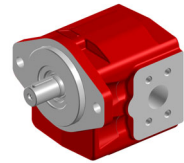

Type	A		B		Suction						Pressure							
	mm	inch	mm	inch	H		D		E		F	H		D		E		F
					mm	inch	mm	inch	mm	inch	mm	mm	inch	mm	inch	mm	inch	mm
40	132	5.20	87.8	3.46	30.17	1.19	58.72	2.31	31.8	1.25	M10x 1.5							
45	135	5.31	90.8	3.57								26.19	1.03	52.37	2.06	25.4	1	
54	140.8	5.54	96.6	3.80														M10x 1.5
63	146.2	5.76	102	4.02	35.71	1.40	69.85	2.75	38.1	1.5	M12x 1.75							
75	153.8	6.06	109.6	4.31								30.17	1.19	58.72	2.31	31.8	1.25	

Pump description example:

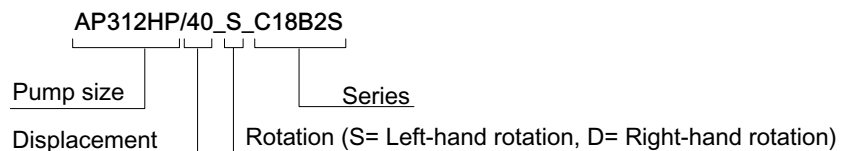

* For C1- C2 dimensions see 3.2

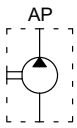

C18B8S
C28B8S

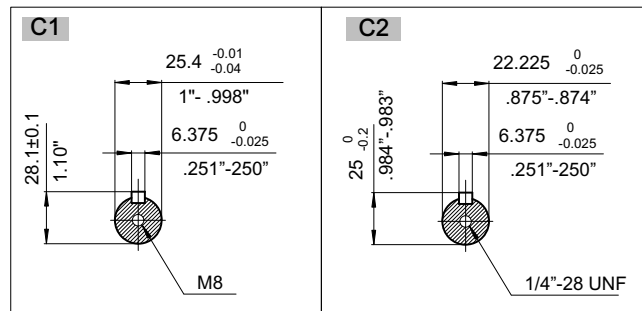
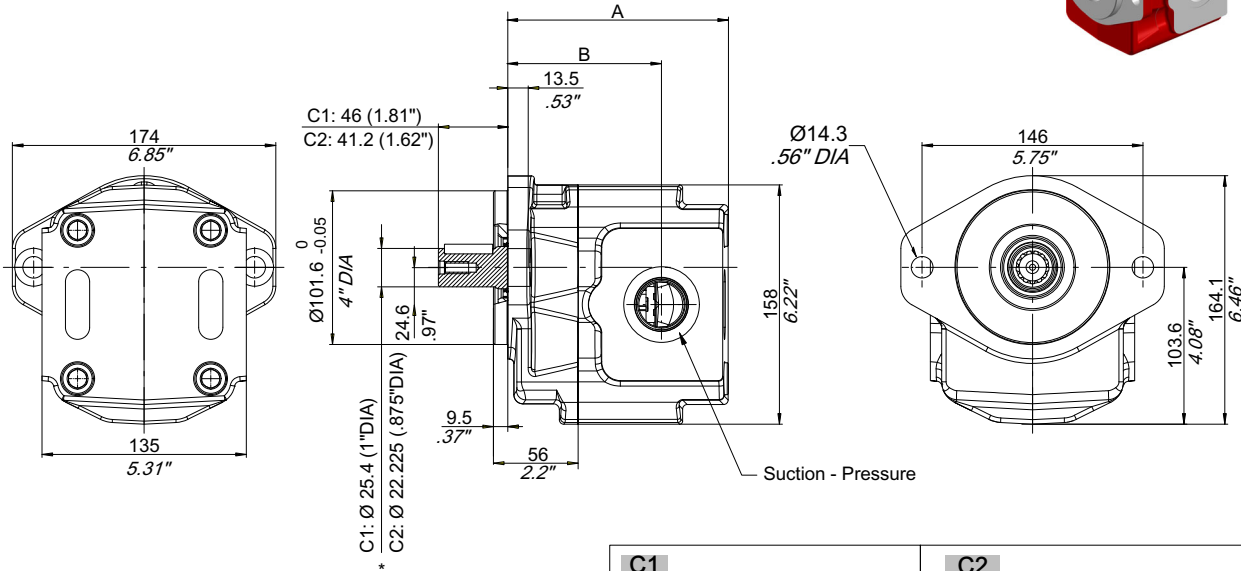
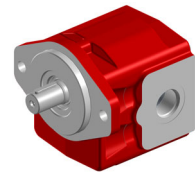

Type	A		B		Suction UNF	Pressure UNF
	mm	inch	mm	inch		
40	132	5.20	87.8	3.46	1 5/8" - 12 UNF-2B (SAE20)	1 5/16" - 12 UNF-2B (SAE16)
45	135	5.31	90.8	3.57		
54	140.8	5.54	96.6	3.80		
63	146.2	5.76	102	4.02		
75	153.8	6.06	109.6	4.31		

Pump description example:

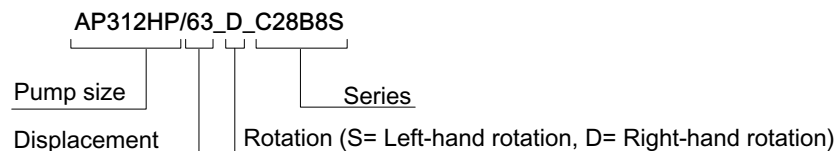

* For C1- C2 dimensions see 3.2

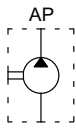

S48C2S

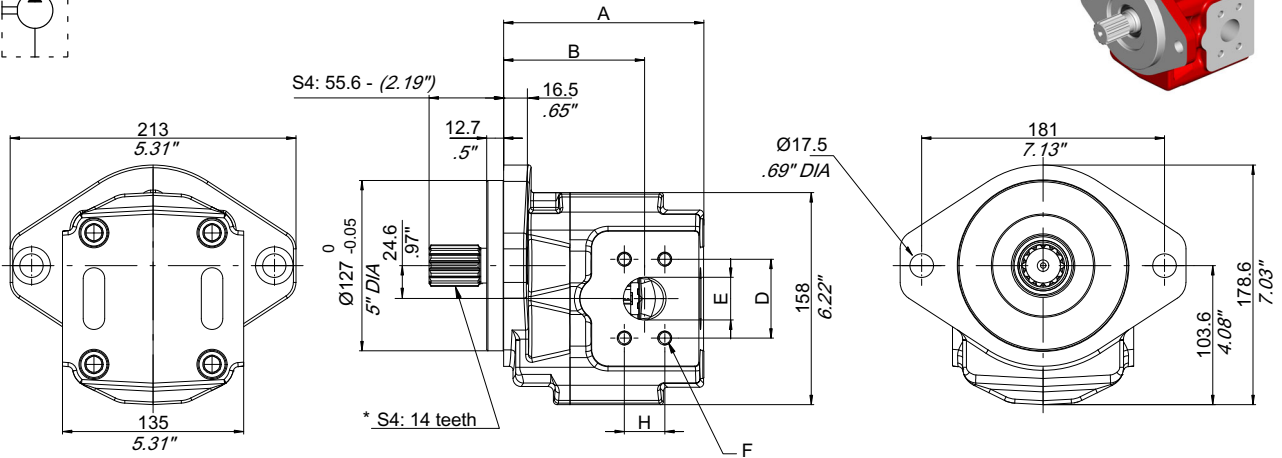
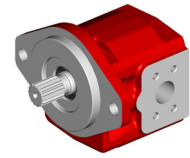

Type	A		B		Suction						Pressure								
	mm	inch	mm	inch	H		D		E		F	H		D		E		F	
					mm	inch	mm	inch	mm	inch	mm	mm	mm	inch	mm	inch	mm	inch	mm
40	135	5.31	90.8	3.57	30.17	1.19	58.72	2.31	31.8	1.25	M10x 1.5								
45	138	5.43	93.8	3.69								26.19	1.03	52.37	2.06	25.4	1		
54	143.8	5.66	99.6	3.92															
63	149.2	5.87	105	4.13	35.71	1.40	69.85	2.75	38.1	1.5	M12x 1.75								
75	156.8	6.17	112.6	4.43								30.17	1.19	58.72	2.31	31.8	1.25		

Pump description example:

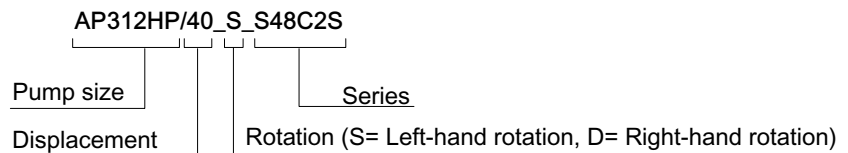

* For S4 dimensions see 3.2

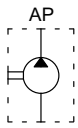

S48C8G

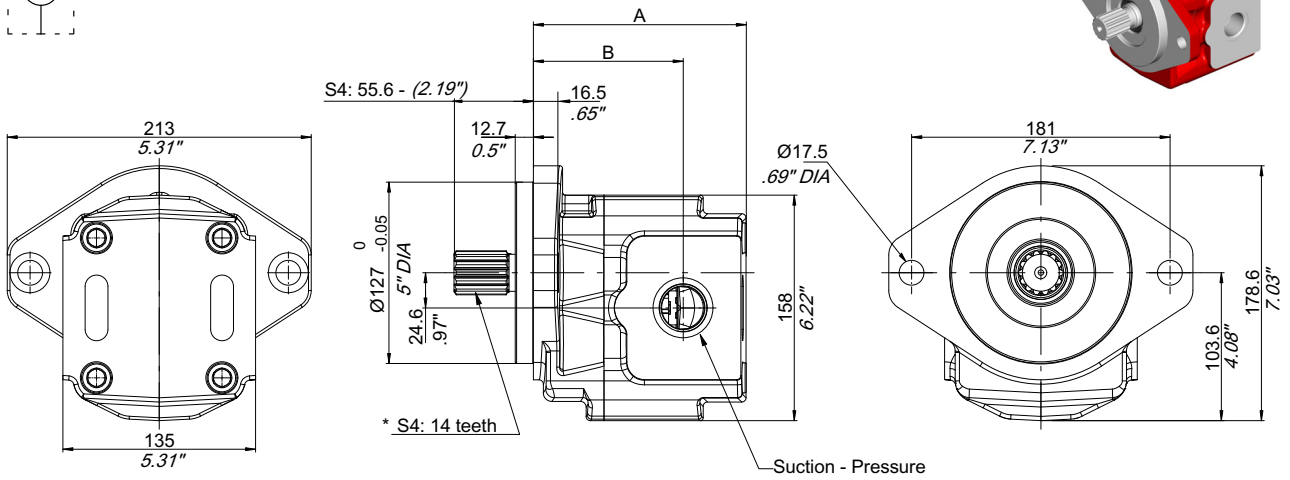
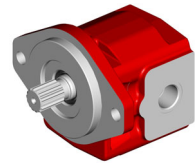

Type	A		B		Suction BSPP	Pressure BSPP
	mm	inch	mm	inch		
40	135	5.31	90.8	3.57	1 1/4" BSP	1" BSP
45	138	5.43	93.8	3.69		
54	143.8	5.66	99.6	3.92		
63	149.2	5.87	105	4.13		
75	156.8	6.17	112.6	4.43		

Pump description example:

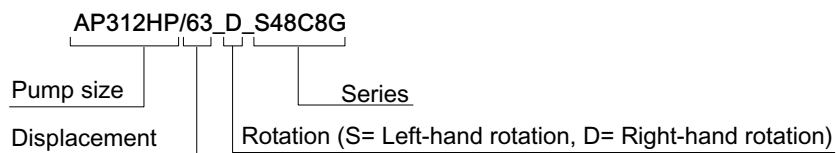

For S4 dimensions see 3.2

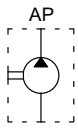

S48C8S

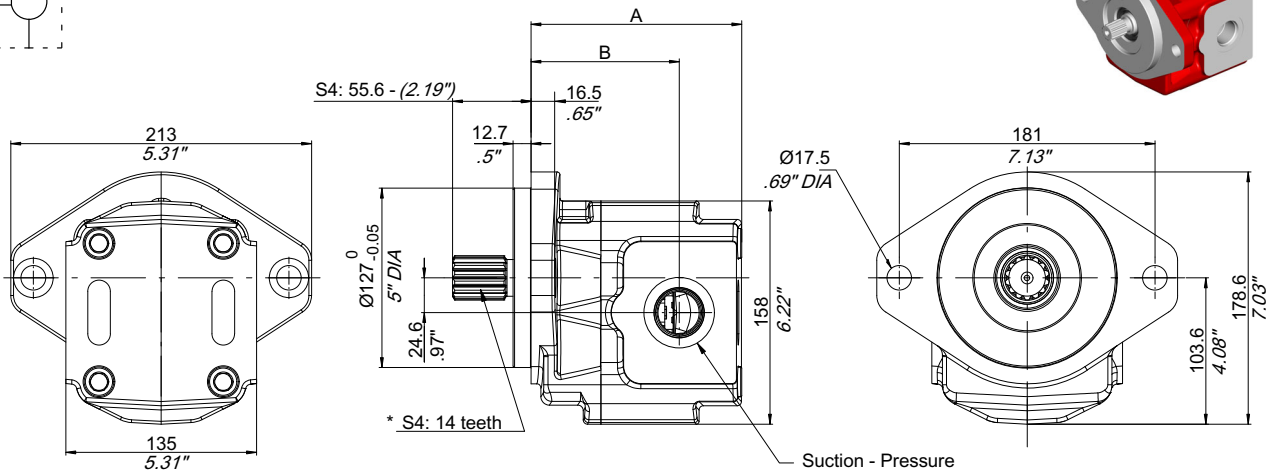
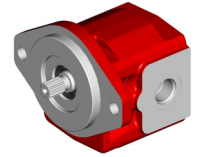

Type	A		B		Suction UNF	Pressure UNF
	mm	inch	mm	inch		
40	135	5.31	90.8	3.57	1 5/8" - 12 UNF-2B (SAE20)	1 5/16" - 12 UNF-2B (SAE16)
45	138	5.43	93.8	3.69		
54	143.8	5.66	99.6	3.92		
63	149.2	5.87	105	4.13		
75	156.8	6.17	112.6	4.43		

Pump description example:

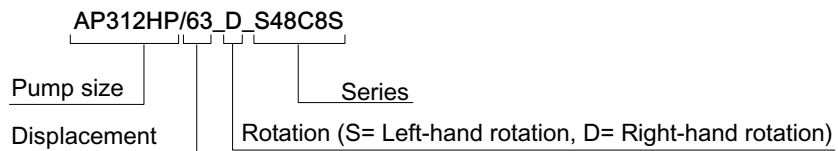

For S4 dimensions see 3.2

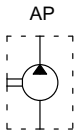

S414C8S
S514C8S

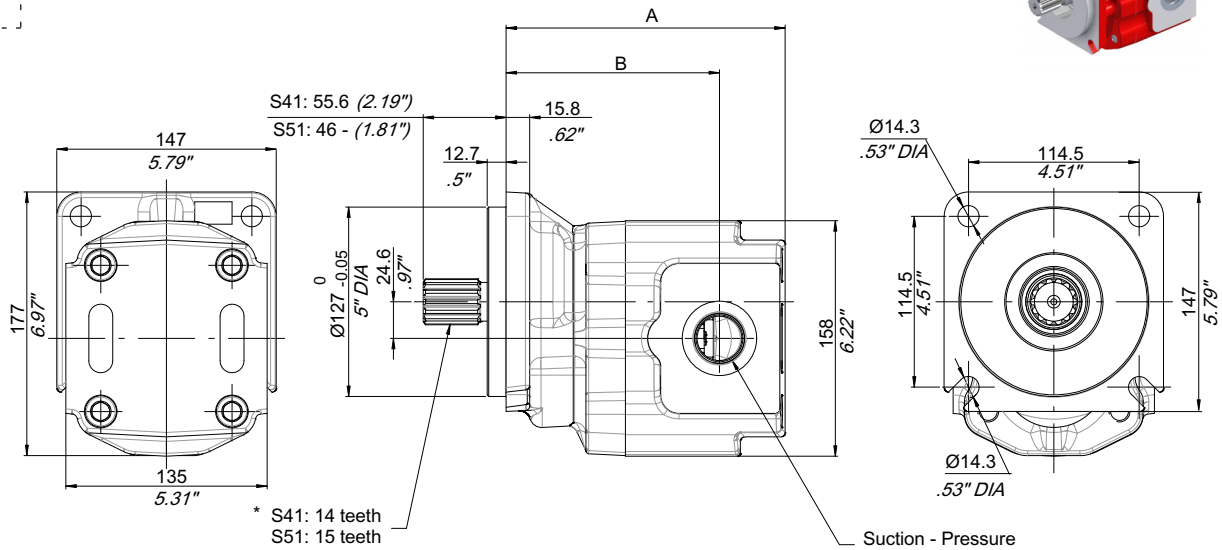
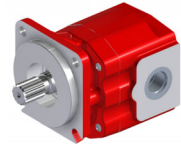

Type	A		B		Suction UNF	Pressure UNF
	mm	inch	mm	inch		
40	165.3	6.51	121.3	4.78	1 5/8" - 12 UNF-2B (SAE20)	1 5/16" - 12 UNF-2B (SAE16)
45	168.3	6.63	124.3	4.89		
54	174.1	6.85	130.1	5.12		
63	179.5	7.07	135.5	5.33		
75	187.1	7.37	143.1	5.63		

Pump description example:

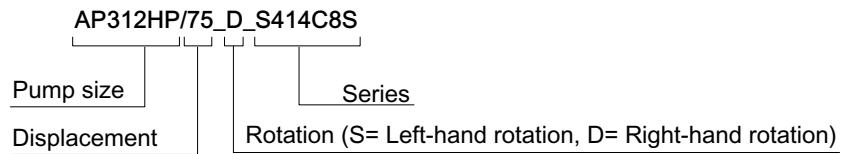

* For S41 and S51 dimensions see 3.2

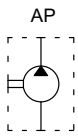

S414C8G
S514C8G

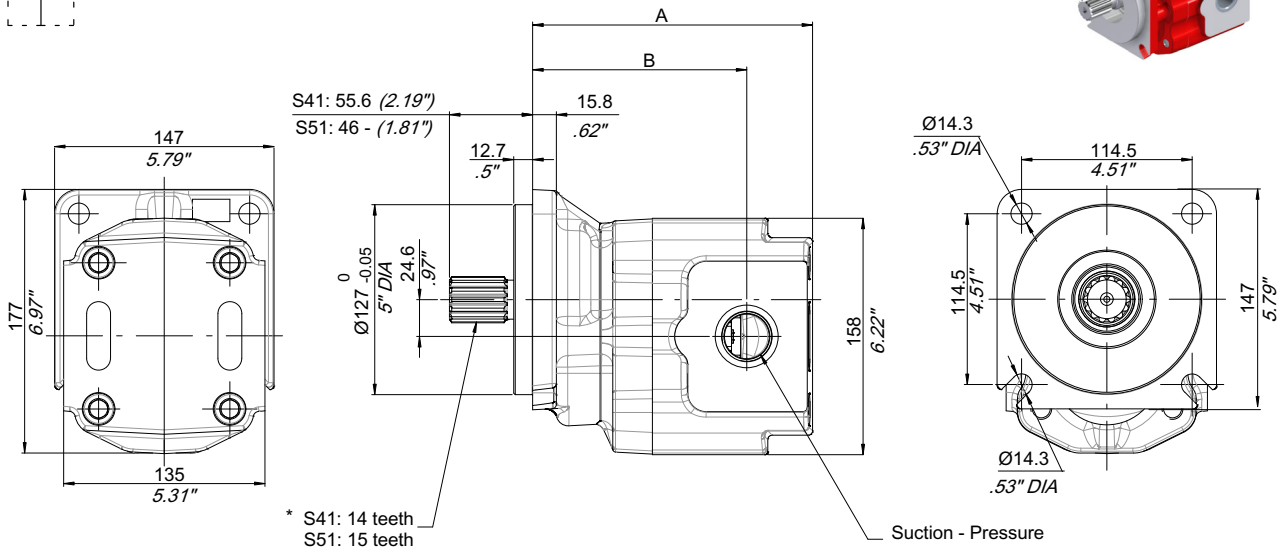
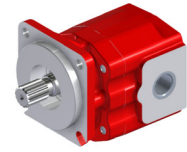

Type	A		B		Suction BSPP	Pressure BSPP
	mm	inch	mm	inch		
40	165.3	6.51	121.3	4.78	1 1/4" BSP	1" BSP
45	168.3	6.63	124.3	4.89		
54	174.1	6.85	130.1	5.12		
63	179.5	7.07	135.5	5.33		
75	187.1	7.37	143.1	5.63		

Pump description example:

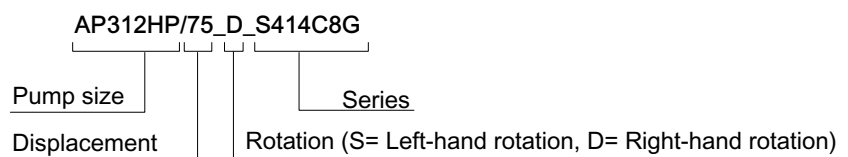

* For S41 and S51 dimensions see 3.2

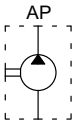

C81P2P

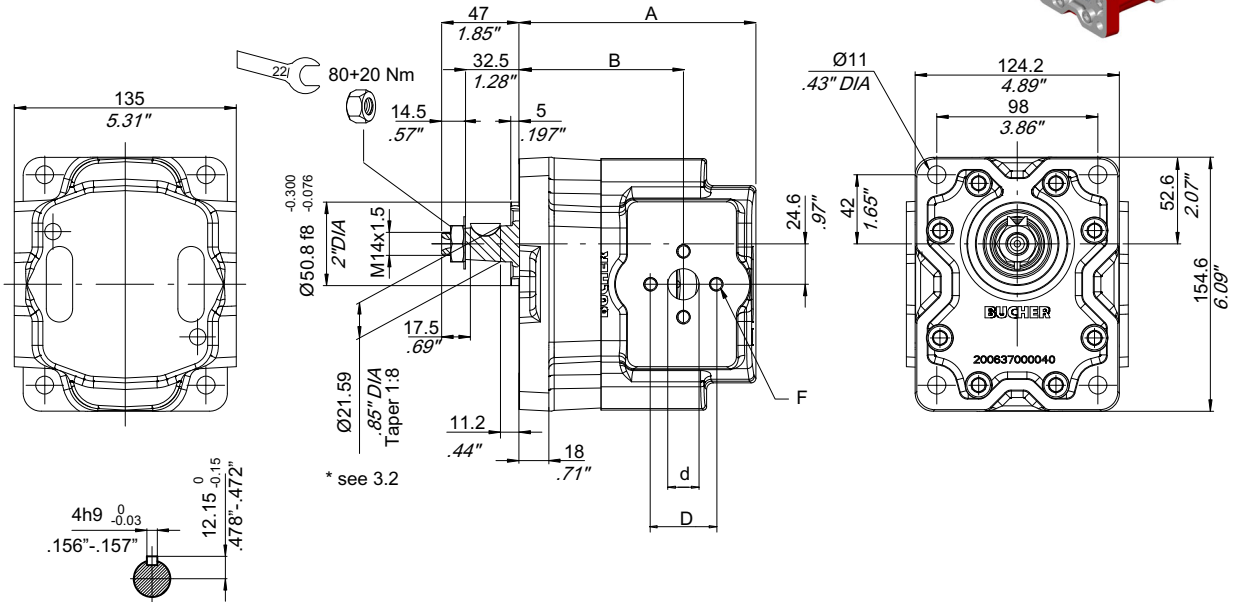
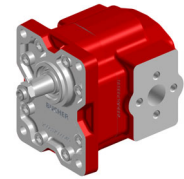

T max= 230 Nm

Type	A		B		Suction					Pressure				
	mm	inch	mm	inch	d	D	F	d	D	F				
40														
45														
54	144.2	5.68	100.1	3.94	27	1.06	51	2.00	M10x 1.5	19	.78	40	1.56	M8x 1.25
63	149.63	5.89	105.53	4.15										
75	157.23	6.19	113.13	4.45	33	1.22	62	2.43	M12x 1.75	27	.98	51	2.00	M10x 1.5

Pump description example:

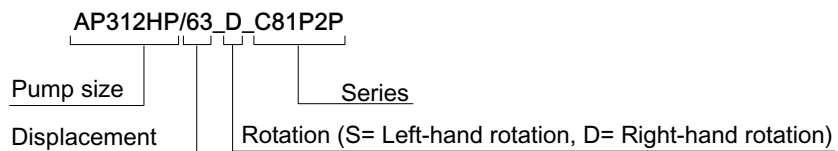

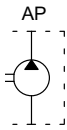

C81P8G

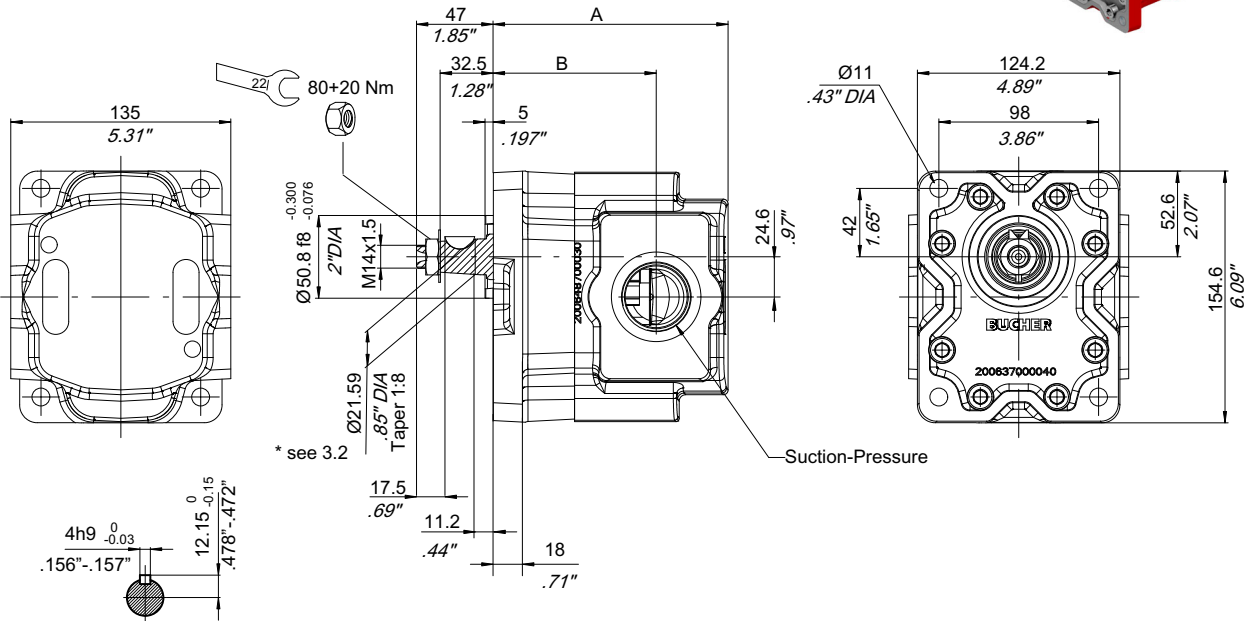
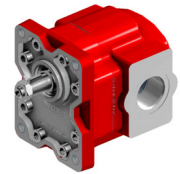

T max= 230 Nm

Type	A		B		Suction BSP	Pressure BSP
	mm	inch	mm	inch		
40						
45						
54	144.2	5.68	100.1	3.94	1 1/4" BSP	1" BSP
63	149.63	5.89	105.53	4.15		
75	157.23	6.19	113.13	4.45		

Pump description example:

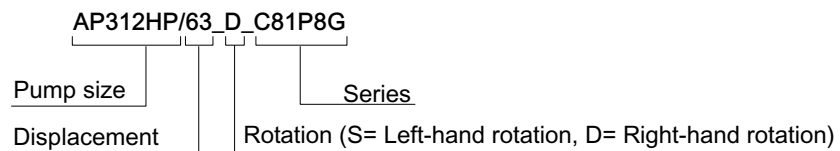

3 AP312HP Single pump customised versions

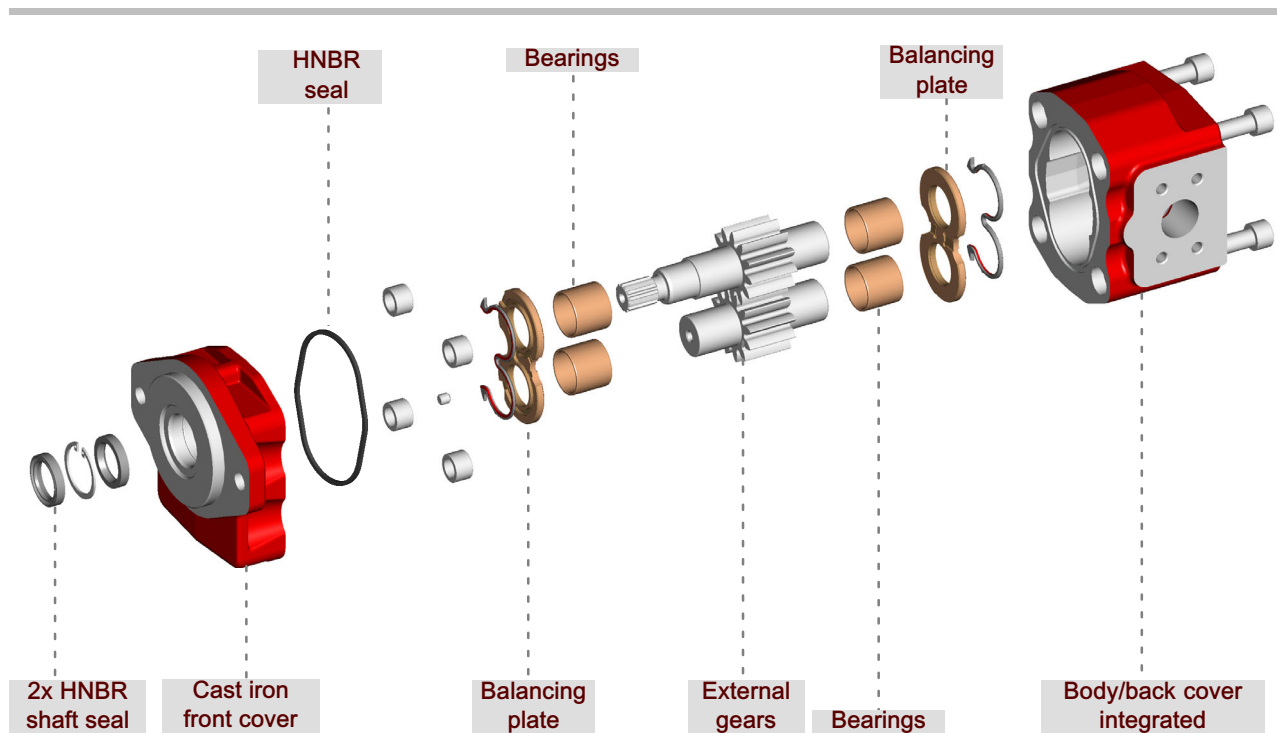

In this section, a single AP312HP pump can be configured and customized.

AP312HP wide availability of covers, bodies and gears provides great flexibility to AP312HP pump range and allows several different pump configurations.

In order to simplify the selection of the desired pump combination, a 'configurator form' is available and, by filling it out, it will guide you in the pump creation process.

3.1 Single pump customised versions order example

A	P	3	1	2	H	P	/	4	0	-	S	-	S	3	8	B	8	G	A	-												*
---	---	---	---	---	---	---	---	---	---	---	---	---	---	---	---	---	---	---	---	---	--	--	--	--	--	--	--	--	--	--	--	---

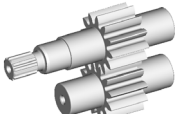
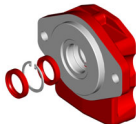
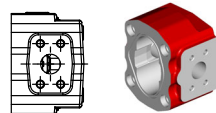
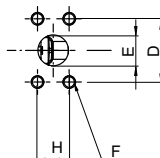
<p>Function AP= single gear pump - unidirectional</p> <p>Series 312HP</p> <p>Displacement 40= 40.2 cm³/rev 45= 45 cm³/rev 54= 54.4 cm³/rev 63= 63.1 cm³/rev 75= 75.3 cm³/rev</p> <p>Rotation S = Left-hand rotation D = Right-hand rotation</p> <p>Shaft end code see section 3.2</p> <p>Front cover type see section 3.3.1</p> <p>Type of ports code see section 3.3.2</p> <p>Inlet/outlet port size code combination see section 3.3.2</p>				
<p>BHRE section : Version - Progressive number (omitted)</p>				

Unpainted pumps are Bucher Hydraulics standard; should a painted component be required, this feature must be specified in its purchase order.

3.2 Shaft end code

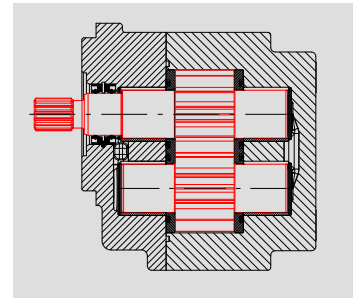
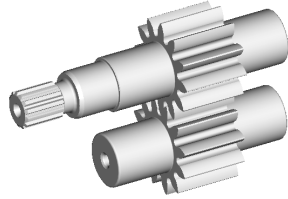

A P 3 1 2 H P / 4 0 - S - S 3

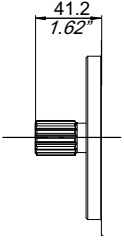
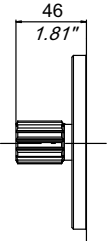
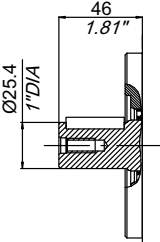
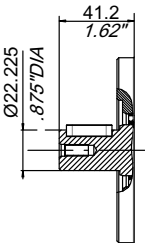
Shaft end shape	Shaft end ordering code	Max torque	Front cover admitted *
 <p>13 teeth external spline SAE J 498-13T 16/32 DP</p>	S3	T max = 270 Nm	SAE-B (8B)
 <p>15 teeth external spline SAE J 498-15T 16/32 DP</p>	S5	T max = 460 Nm	SAE-B (8B)
 <p>Straight keyed Ø 25.4 mm - 1 inches</p>	C1	T max = 280 Nm	SAE-B (8B)
 <p>Straight keyed Ø 22.225 mm - 0.875 inches</p>	C2	T max = 185 Nm	SAE-B (8B)

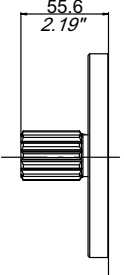
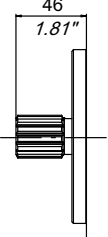
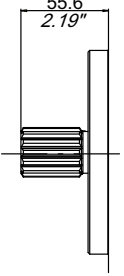
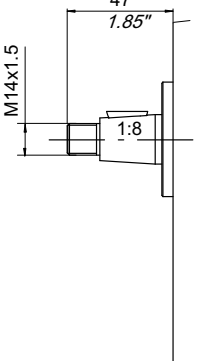
Shaft end shape	Shaft end ordering code	Max torque	Front cover admitted *
	<p>14 teeth external spline SAE J 498-14T 12/24 DP</p>	<p>S4</p>	<p>T max = 950 Nm</p> <p>SAE-C 2 fixing holes (8C)</p>
	<p>15 teeth external spline SAE J 498-15T 16/32 DP</p>	<p>S51</p>	<p>T max = 460 Nm</p> <p>SAE-C 4 fixing holes (4C)</p>
	<p>14 teeth external spline SAE J 498-14T 12/24 DP</p>	<p>S41</p>	<p>T max = 950 Nm</p> <p>SAE-C 4 fixing holes (4C)</p>
	<p>Tapered shaft 1:8</p>	<p>C8</p>	<p>T max = 230 Nm</p> <p>European rectangular (1P)</p>

* For different combinations please contact our Sales Center.

3.3 Front cover/mounting flange

3.3.1 Front cover type

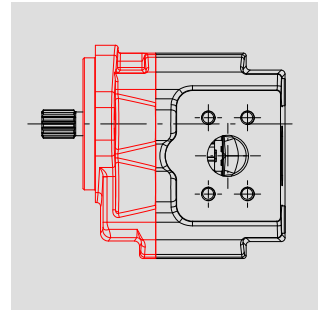
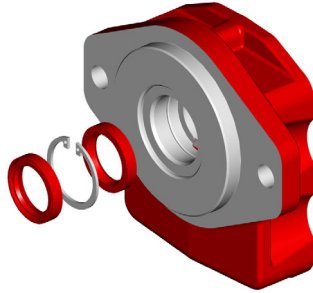

A P 3 1 2 H P / 4 0 - S - S 3 8 B



Type	Cast iron	
	Shape	Ordering code
SAE-B (Ø 101.6 mm - 4 inches) with HNBR shaft seals		8B
SAE-C 2 fixing holes (Ø 127 mm - 5 inches) with HNBR shaft seals		8C SAE-C 2 fixing holes front flange should be combined with 14T shaft's end, for different ends please contact Sales Department
SAE-C 4 fixing holes (Ø 127 mm - 5 inches) with HNBR shaft seals Flange 4C refers to standard applications without axial and radial loads. For applications requiring bearings, please contact our Sales Department.		4C SAE-C 4 fixing holes front flange should be combined with 14T and 15T shaft's end, for different ends please contact Sales Department
European rectangular (Ø 50.8 mm - 2 inches) with HNBR shaft seals		1P

SAE-B

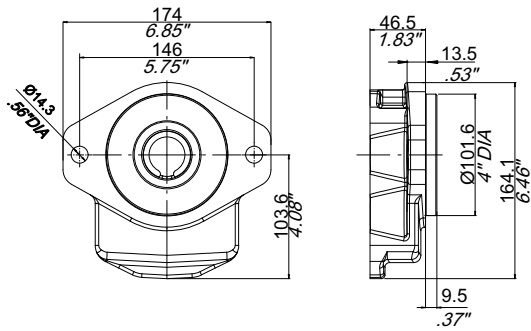

SAE-C 2 fixing holes

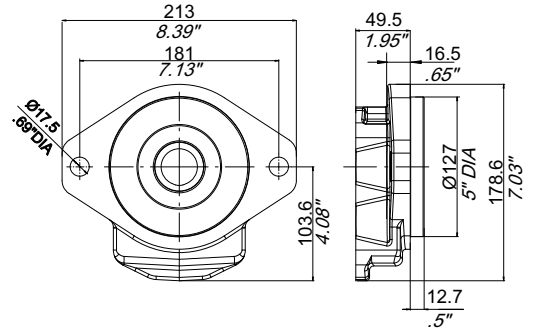

European

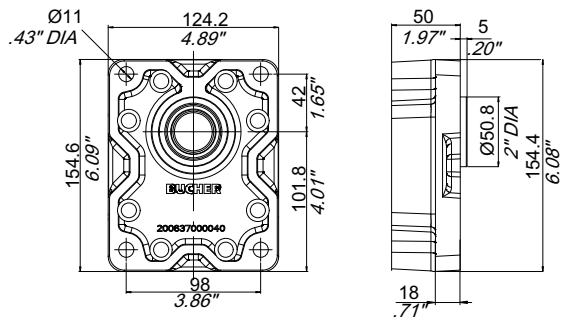

SAE-C 4 fixing holes

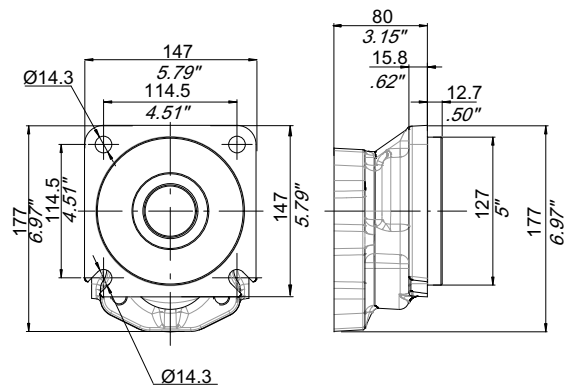

3.3.2 Port types

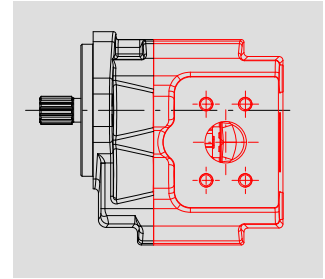
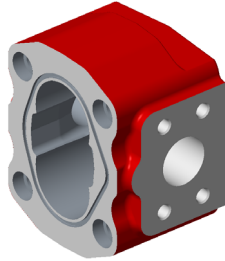
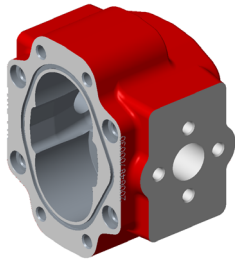

A P 3 1 2 H P / 4 0 - S - S 3 8 B 8 G A

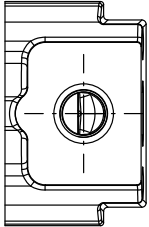
Port type (SAE-B, SAE-C, EU)	Ordering code	Displacement	Dimension (mm - inches)		
			Suction	Pressure	code
	BSP ports	40-45-54 63-75	1 1/4" BSP	1" BSP	A

1 1/4" BSP

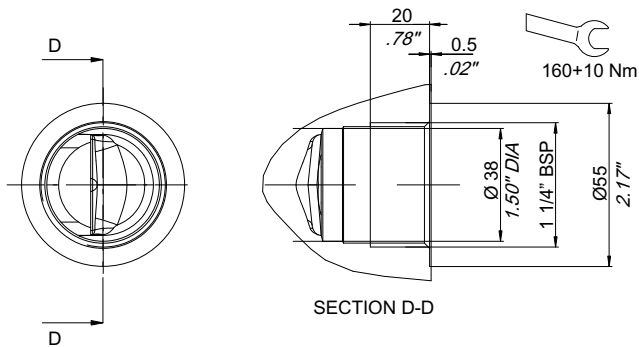

1" BSP

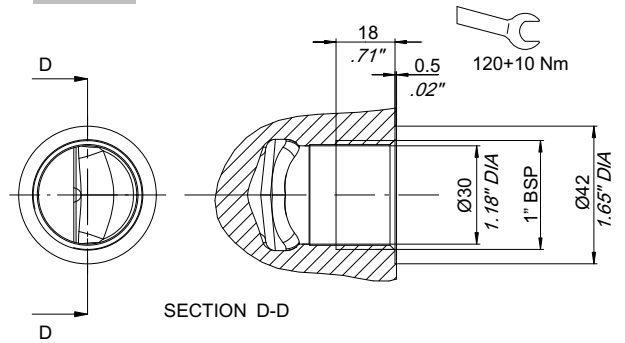

IMPORTANT!: Tightening torques depends on several different factors including lubrication, coating and surfaces finish. The fitting manufacturer shall be consulted.

In the interest of safety, only fittings with STRAIGHT THREAD ENDS should be used (e.g. DIN3852).

Fittings with TAPERED THREAD ENDS (e.g. DIN 3852 form C) should never be used, as they can cause deformation and cracks in the valve body.

Our warranty conditions will not be valid in case tapered fittings are used.

The work port adaptors have to be fastened respecting the tightening torque values indicated.

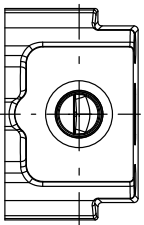
Port type (SAE-B, SAE-C, EU)	Ordering code	Displacement	Dimension (mm - inches)		
			Suction	Pressure	code
	8S	40-45-54-63-75	1 5/8"-12 UNF-2B (SAE20)	1 5/16"-12 UNF-2B (SAE16)	A

1 5/8"-12 UNF-2B (SAE20)

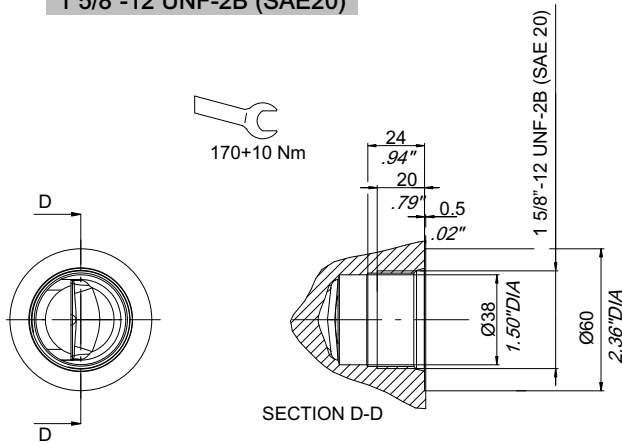

1 5/16" 12 UNF-2B (SAE16)

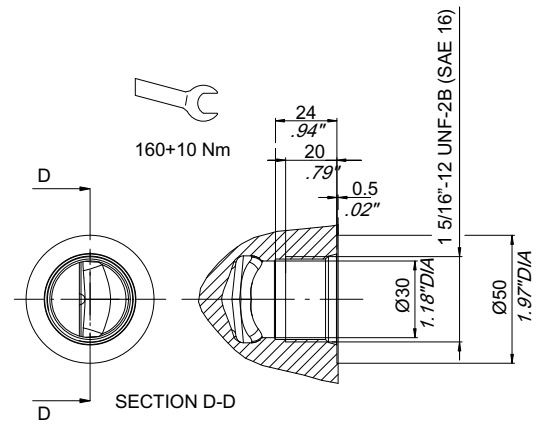

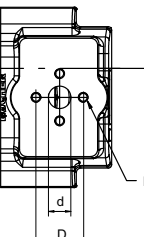
Port type (SAE-B, SAE-C, EU)	Ordering code	Displacement	Dimension (mm - inches)		
			Suction	Pressure	code
	2P	54-63	27 - 1.06 (d) 51 - 2.00 (D) M10x1.5 (F)	19 - 0.78 (d) 40 - 1.56 (D) M8x1.25 (F)	A
		75	33 - 1.22 (d) 62 - 2.43 (D) M12x1.75 (F)	27 - 1.06 (d) 51 - 2.00 (D) M10x1.5 (F)	B

33/62

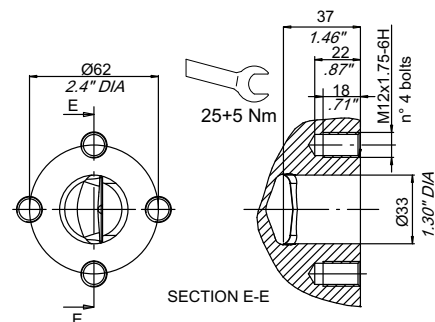

27/51

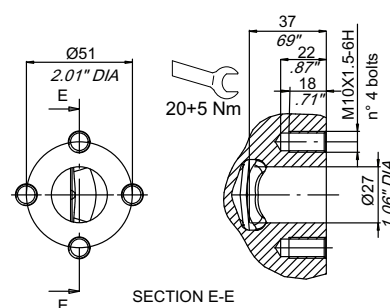

19/40

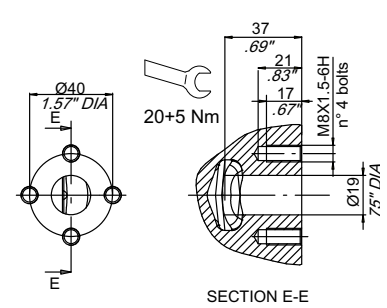

IMPORTANT! Tightening torques depends on several different factors including lubrication, coating and surfaces finish. The fitting manufacturer shall be consulted.

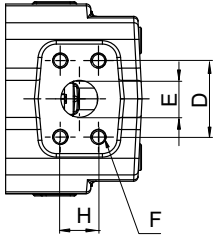
Port type These flanges are available for SAE-B and SAE-C body type, only. NOT available for European version	Ordering code	Displacement	Dimension (mm - inches)								code
			Suction				Pressure				
			H	D	E	F	H	D	E	F	
 SAE FLANGED PORTS J518 (3000 PSI series)	2S	40	30.17 1.19"	58.72 2.31"	31.8 1.25"	M10 x1.5	26.19 1.03"	52.37 2.06"	25.4 1"	M10 x1.5	A
		45-54	35.71 1.14"	69.85 2.75"	38.1 1.5"	M12 x1.75	30.17 1.19"	58.72 2.31"	31.8 1.5"		C
		63-75									

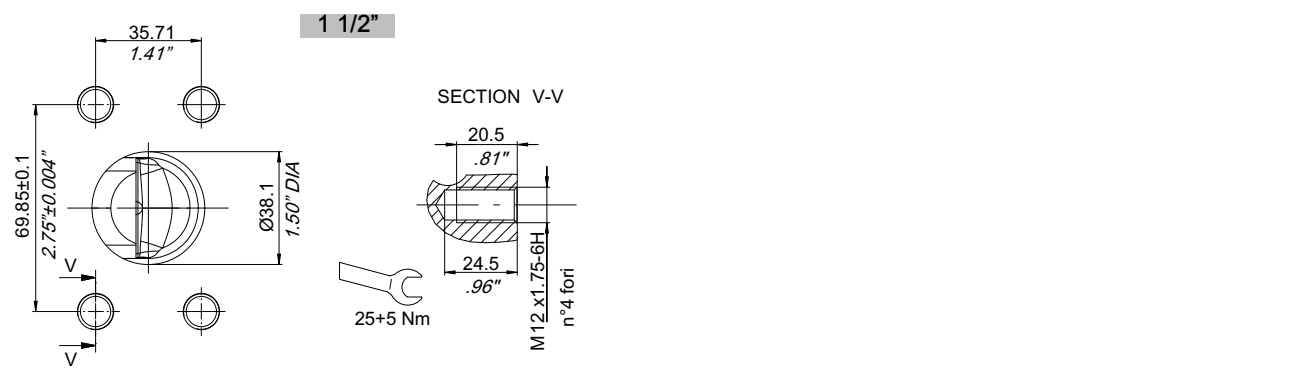
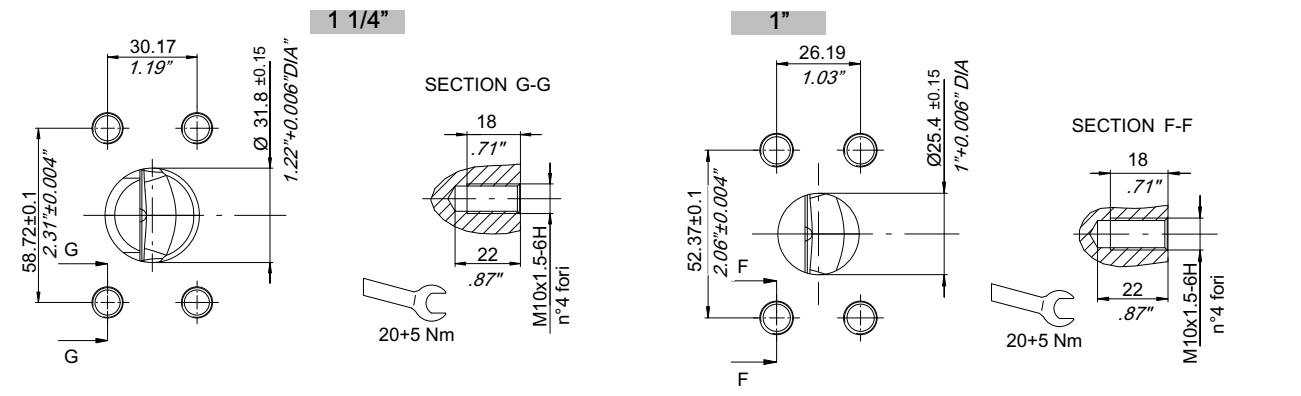

Other ports	9	If the requested port type is not included in the previous versions, please indicate number "9" and specify the details in the request note
-------------	---	---

3.4 Single pump dimensions

Pump with SAE-B front cover

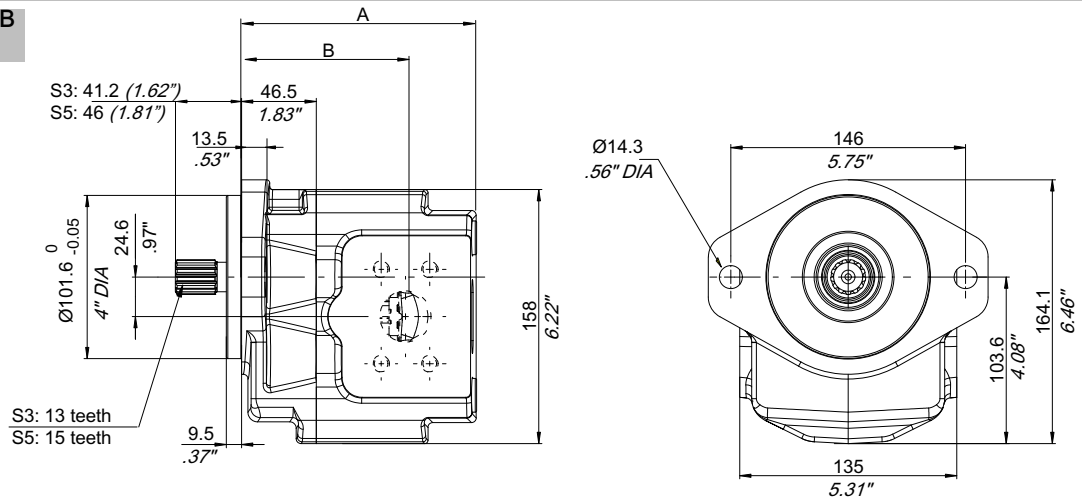

Pump size	A		B	
	mm	inch	mm	inch
AP312HP/40	132	5.20	87.8	3.46
AP312HP/45	135	5.31	90.8	3.57
AP312HP/54	140.8	5.54	96.6	3.80
AP312HP/63	146.2	5.76	102	4.02
AP312HP/75	153.8	6.06	109.6	4.31

Pump with SAE-C 2 fixing holes front cover

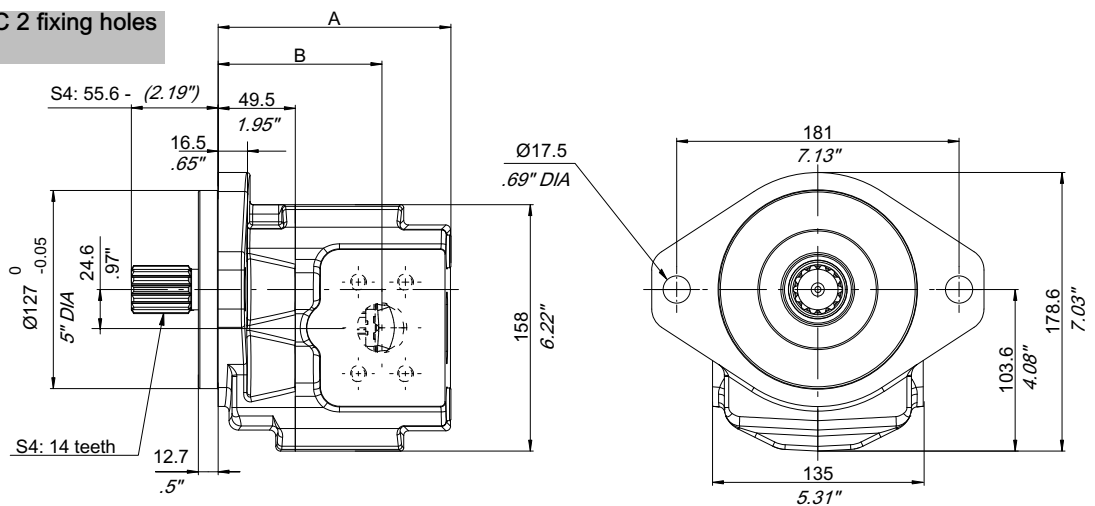

Pump size	A		B	
	mm	inch	mm	inch
AP312HP/40	135	5.31	90.8	3.57
AP312HP/45	138	5.43	93.8	3.69
AP312HP/54	143.8	5.66	99.6	3.92
AP312HP/63	149.2	5.87	105	4.13
AP312HP/75	156.8	6.17	112.6	4.43

Pump with SAE-C 4 fixing holes front cover

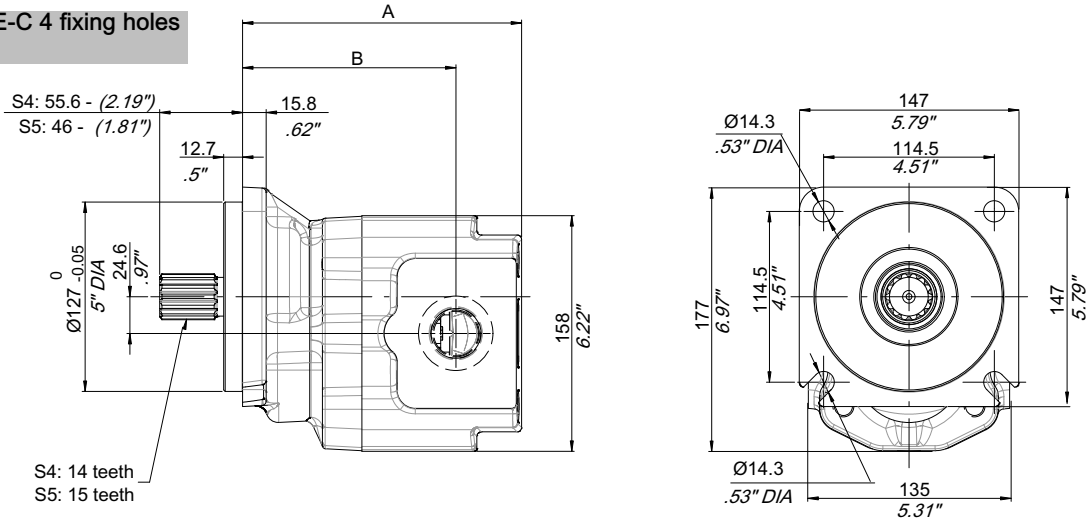

Type	A		B	
	mm	inch	mm	inch
40	165.3	6.51	121.3	4.78
45	168.3	6.63	124.3	4.89
54	174.1	6.85	130.1	5.12
63	179.5	7.07	135.5	5.33
75	187.1	7.37	143.1	5.63

Pump with European body and front cover

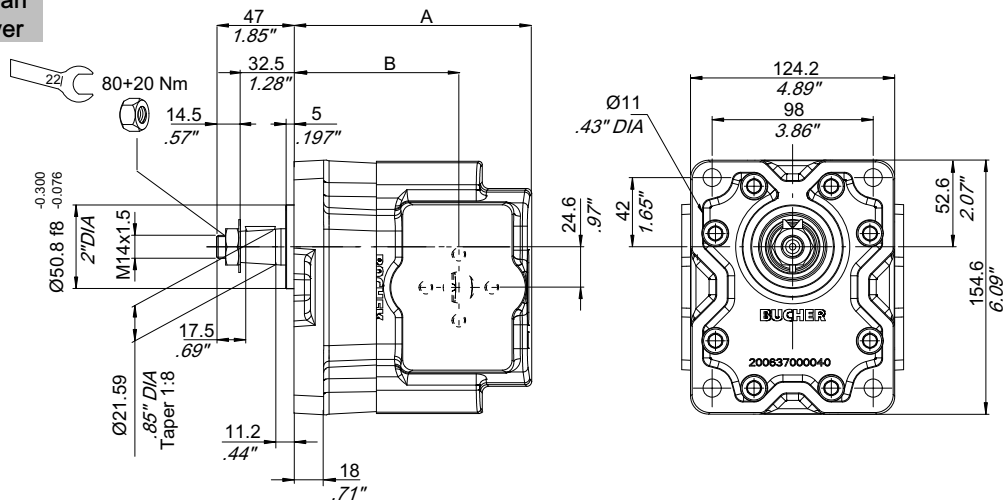

Type	A		B	
	mm	inch	mm	inch
AP312HP/40	-	-	-	-
AP312HP/45	-	-	-	-
AP312HP/54	144.2	5.68	100.1	3.94
AP312HP/63	149.63	5.89	105.53	4.15
AP312HP/75	157.23	6.19	113.13	4.45

4 Multiple gear pumps

4.1 Multiple gear pumps: AP312HP+AP312HP standard cast iron versions

(SAE-B and SAE-C 2 and 4 fixing holes only, no European version)

Standard versions means separated inlet/outlet side ports, without shaft seal between pump stages

4.1.1 Drive torque calculation example

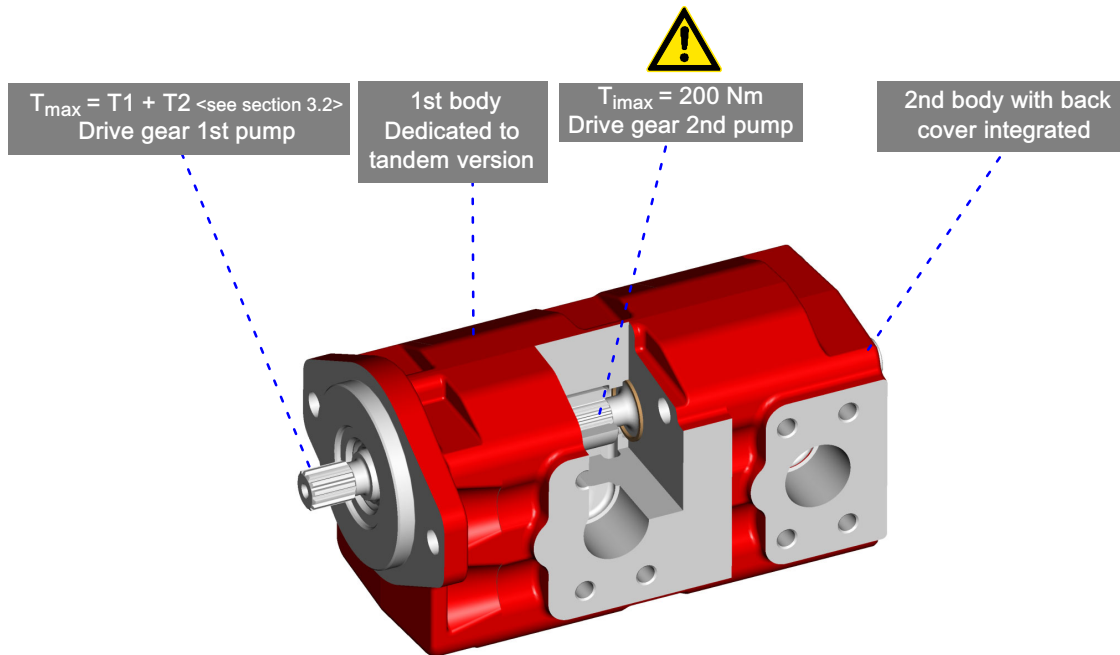

$$T_{\max} = 1.59 \cdot \frac{p_1 \cdot V_{c1}}{\eta_{m1}} + 1.59 \cdot \frac{p_2 \cdot V_{c2}}{\eta_{m2}}$$

Example: AP312HP/75 + AP312HP/54

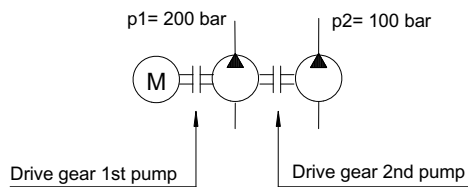

$$T_{\max} = 1.59 \cdot \frac{75 \cdot 200}{90} + 1.59 \cdot \frac{54 \cdot 100}{90} = 265 + 95.4 = 360.4 \text{ Nm}$$

$$T_{\max} = 360.4 \leq 460 \text{ Nm (splined 15T)}$$

$$T_2 = 95.4 \leq T_{\max} 200 \text{ Nm}$$

Common suction versions available on request.
Please contact our Sales Department.

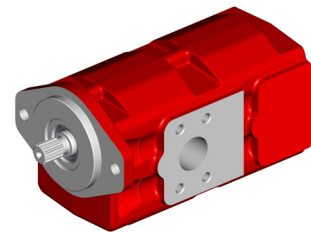

4.1.2 Tandem pumps dimensions

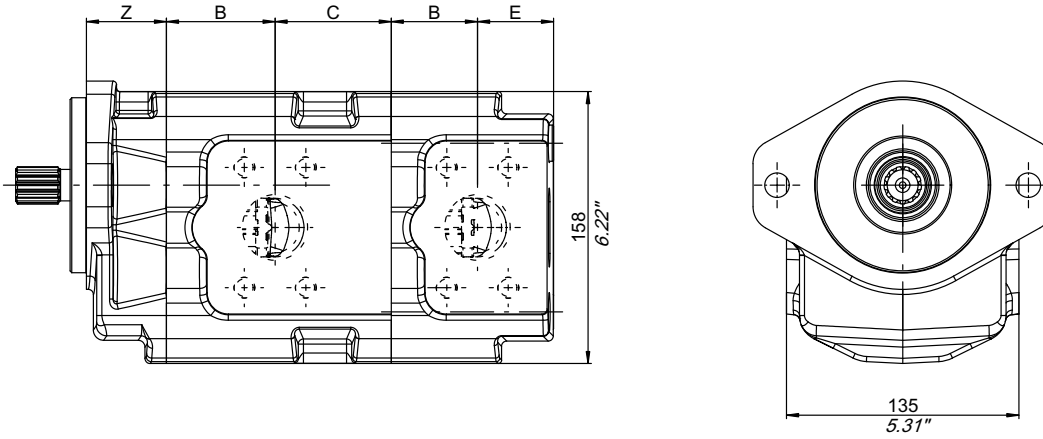
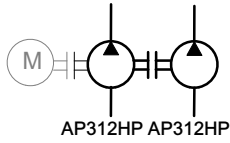

Pump size AP312HP	B		C		E	
	mm	inch	mm	inch	mm	inch
AP312HP/40	41.3	1.63	67.5	2.66	44.2	1.74
AP312HP/45	44.3	1.74	67.5	2.66	44.2	1.74
AP312HP/54	50.1	1.98	67.5	2.66	44.2	1.74
AP312HP/63	55.5	2.19	67.5	2.66	44.2	1.74
AP312HP/75	63.1	2.48	67.5	2.66	44.2	1.74

Front cover dimensions	SAE-B		SAE-C 2 fixing holes		SAE-C 4 fixing holes	
	mm	inch	mm	inch	mm	inch
Z	46.5	1.83	49.5	1.95	80	3.15

For other covers dimensions see 3.3.1

4.1.3 Dimensions example

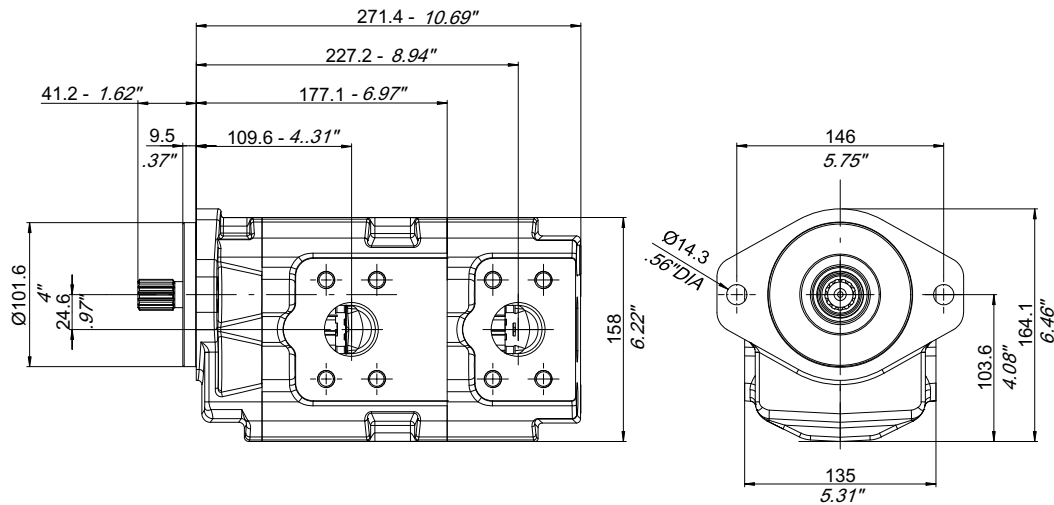

Example AP312HP/75+AP312HP/54 (SAE-B front cover):

Total length: $271.4 = (Z+B+C+B+E) = 46.5 + 63.1 + 67.5 + 50.1 + 44.2$

Port position: $227.2 = (Z+B+C+B) = 46.5 + 63.1 + 67.5 + 50.1$

$109.6 = (Z+B) = 46.5 + 63.1$

4.1.4 How to order tandem pumps AP312HP+AP312HP standard cast iron versions

		1 st PUMP							2 nd PUMP				1 st BODY		2 nd BODY																						
1	2	3	4	5	6	7	8	9	10	11	12	13	14	15	16	17	18	19	20	21																	
A	P	3	1	2	H	P	/	7	5	-	5	4	-	S	-	S	3	8	B	2	S	C	-	2	S	B	-										

1 Function
AP= single gear pump - unidirectional

2 Series
312HP

3 Displacement
40= 40.2 cm³/rev
45= 45 cm³/rev
54= 54.4 cm³/rev
63= 63.1 cm³/rev
75= 75.3 cm³/rev

4 Rotation
S = left-hand rotation
D = Right-hand rotation

5 Shaft end code
see section 3.2

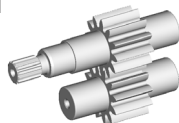

6 Front cover type
see section 3.3.1

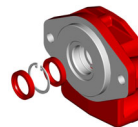

7 Type of ports code
see section 3.3.2

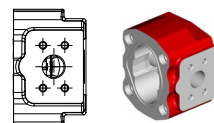

8 Inlet/outlet port size code combination
see section 3.3.2

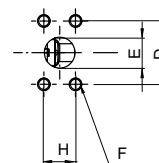

9 BHRE section :
Version - Progressive number (omitted)

Unpainted pumps are Bucher Hydraulics standard; should a painted component be required, this feature must be specified in its purchase order.

4.2 Multiple gear pumps: AP312HP+AP212HP standard cast iron versions

(Tandem pumps combination of group 3 with group 2 are possible for SAE-B, SAE-C 2 and 4 fixing holes and European versions, too)

Standard versions means separated inlet/outlet side ports, without shaft seal between pump stages

4.2.1 Drive torque calculation example

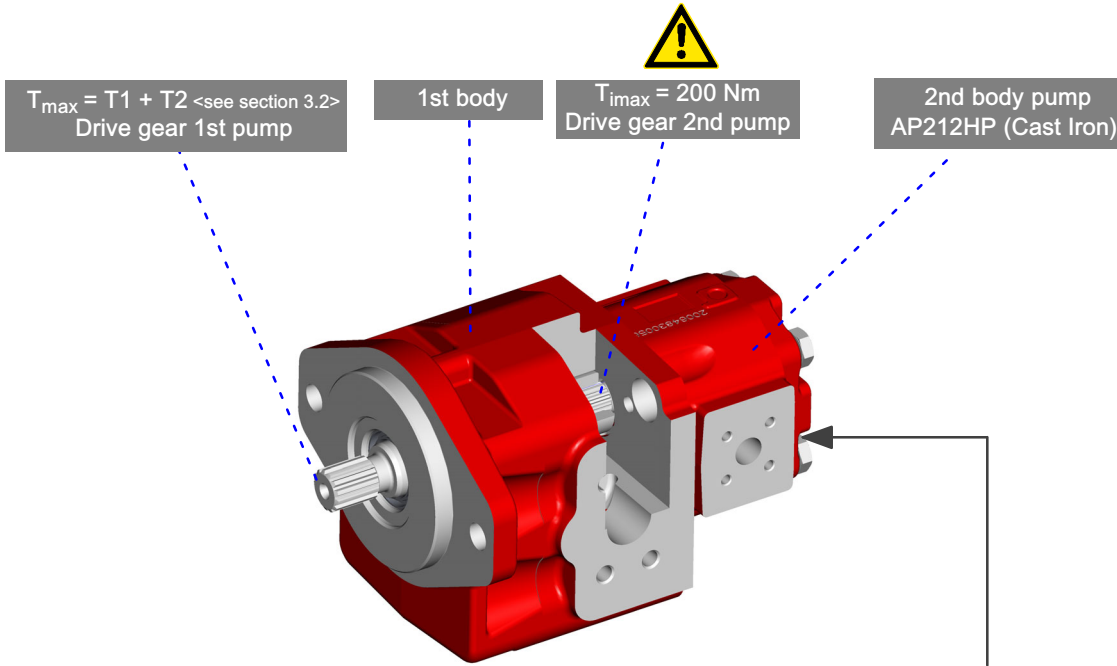

$$T_{\max} = 1.59 \cdot \frac{p_1 \cdot V_{c1}}{\eta_{m1}} + 1.59 \cdot \frac{p_2 \cdot V_{c2}}{\eta_{m2}}$$

Example: AP312HP/45 + AP212HP/15

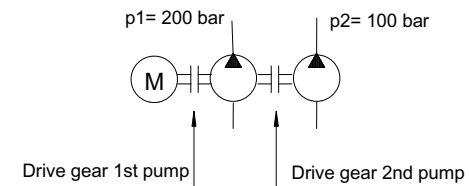

$$T_{\max} = 1.59 \cdot \frac{45 \cdot 200}{90} + 1.59 \cdot \frac{15 \cdot 100}{90} = 159 + 26.5 = 185.5 \text{ Nm}$$

$$T_{\max} = 185.5 \leq 230 \text{ Nm (splined 13T)}$$

$$T_2 = 26.5 \leq T_{\max} 200 \text{ Nm}$$

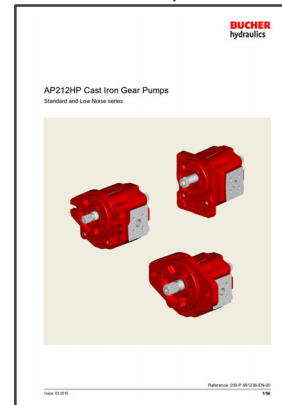

Further information regarding group 2 pumps: see dedicated "AP212HP Cast Iron Gear Pumps" catalogue

4.2.2 Tandem pumps dimensions

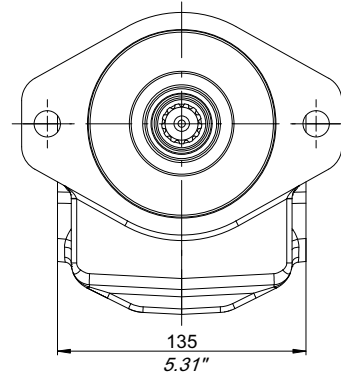
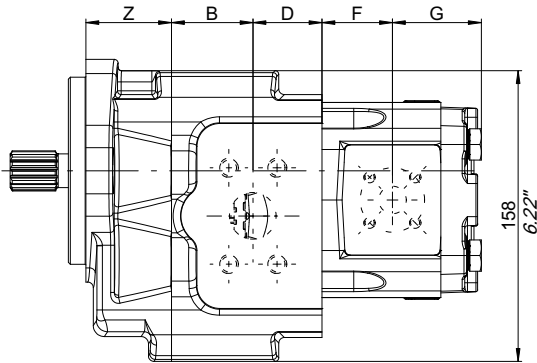
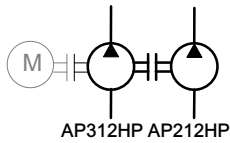

Pump size SAE-B, SAE-C	B		D		Pump size European version	B		D	
	mm	inch	mm	inch		mm	inch	mm	inch
AP312HP/40	41.3	1.63	37.5	1.48	-----	-----	-----	-----	-----
AP312HP/45	44.3	1.74	37.5	1.48	-----	-----	-----	-----	-----
AP312HP/54	50.1	1.97	37.5	1.48	AP312HP/54	50.1	1.97	37.5	1.48
AP312HP/63	55.5	2.19	37.5	1.48	AP312HP/63	55.5	2.19	37.5	1.48
AP312HP/75	63.1	2.48	37.5	1.48	AP312HP/75	63.1	2.48	37.5	1.48

Front cover dimensions	SAE-B		SAE-C 2 fixing holes		SAE-C 4 fixing holes		European	
	mm	inch	mm	inch	mm	inch	mm	inch
Z	46.5	1.83	49.5	1.95	80	3.15	50	1.97

For other covers dimensions see 3.3.1

Pump size AP212HP	F		G	
	mm	inch	mm	inch
AP212HP/15	38.3	1.51	48.3	1.90
AP212HP/19	41.3	1.63	51.3	2.01
AP212HP/22	43.55	1.71	55.55	2.11
AP212HP/26	46.55	1.83	56.55	2.23
AP212HP/29	48.55	1.91	58.55	2.31
AP212HP/33	51.55	2.03	61.55	2.42

4.2.3 Dimensions example

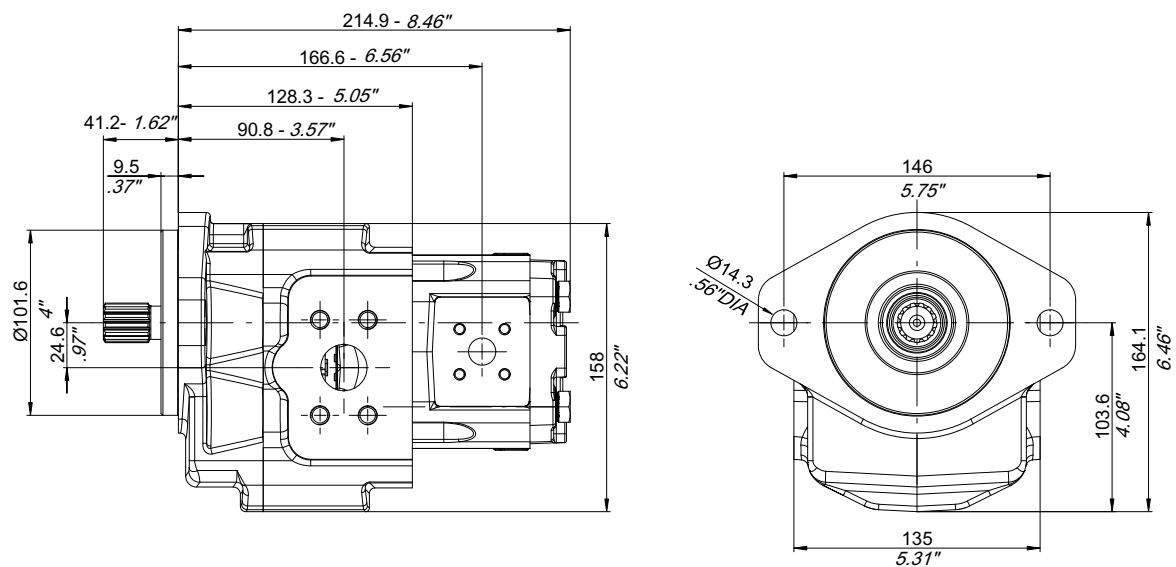

Example AP312HP/45+AP212HP/15 (SAE-B front cover):

Total length: $214.9 = (Z+B+D+F+G) = 46.5+44.3+37.5+38.3+48.3$

Port position: $166.6 = (Z+B+D+F) = 46.5+44.3+37.5+38.3$

$90.8 = (Z+B) = 46.5+44.3$

4.2.4 How to order tandem pumps AP312HP+AP212HP standard cast iron versions

		1 st PUMP					2 nd PUMP					1 st BODY		2 nd BODY																						
1	2					22					23	4	5	6	7	8	27																			
A	P	3	1	2	H	P	/	4	5	-	2	1	2	H	P	/	1	5	-	S	-	S	3	8	B	2	S	B	-	2	B	-				

1 Function
AP= single gear pump - unidirectional

2 Series
312HP (Cast iron)

3 Displacement
40= 40.2 cm³/rev
45= 45 cm³/rev
54= 54.4 cm³/rev
63= 63.1 cm³/rev
75= 75.3 cm³/rev

4 Rotation
S = left-hand rotation
D = Right-hand rotation

5 Shaft end code
see section 3.2

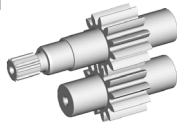

6 Front cover type
see section 3.3.1

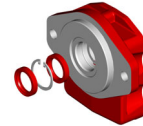

7 Type of ports code
see section 3.3.2

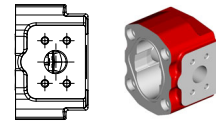

8 Inlet/outlet port size code combination
see section 3.3.2

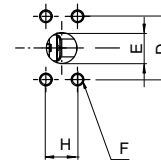

**9 BHRE section :
Version - Progressive number (omitted)**

AP212HP

22 Series
212HP (Cast iron)

23 Displacement
212HP
15= 15.1 cm³/rev
19= 19.2 cm³/rev
22= 22.2 cm³/rev
26= 26.2 cm³/rev
29= 28.9 cm³/rev
33= 33 cm³/rev

24 Version
Omitted if 12 teeth standard
LN= 12 teeth Low Noise version

27 Type of ports code
see section 3.5 AP212HP Catalogue

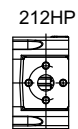

28 Inlet/outlet port size code combination
see section 3.5 AP212HP Catalogue

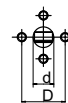

29 Body material
see section 3.5.1 AP212HP Catalogue



30 Back cover type / Valve setting value
see section 3.6 AP212HP Catalogue

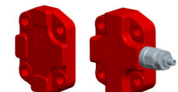

Unpainted pumps are Bucher Hydraulics standard; should a painted component be required, this feature must be specified in its purchase order.

4.3 Multiple gear pumps: AP312HP+AP212 aluminium version

(Tandem pumps combination of group 3 with group 2 are possible for SAE-B, SAE-C 2 and 4 fixing holes and European versions, too)

Standard versions means separated inlet/outlet side ports, without shaft seal between pump stages

4.3.1 Drive torque calculation example

$T_{max} = T_1 + T_2$
 <see section 3.2>
 Drive gear 1st pump

1st body



$T_{imax} = 200 \text{ Nm}$
 Drive gear 2nd pump

2nd body pump
 AP212 (aluminium)

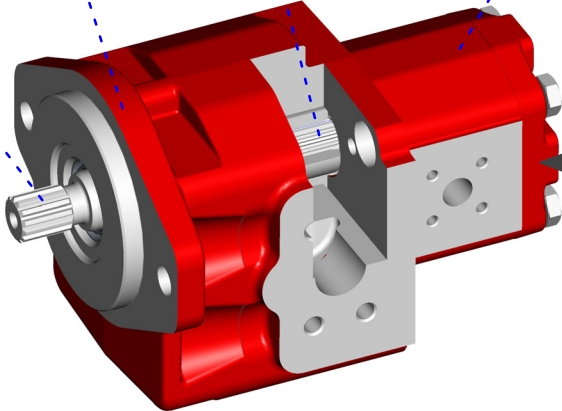

$$T_{max} = 1.59 \cdot \frac{p_1 \cdot V_{c1}}{\eta_{m1}} + 1.59 \cdot \frac{p_2 \cdot V_{c2}}{\eta_{m2}}$$

Example: AP312HP/45 + AP212/15

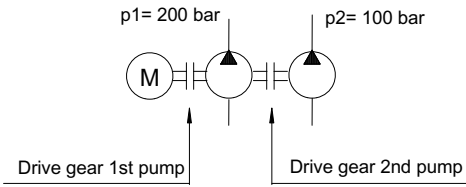



Further information regarding group 2 pumps: see dedicated "AP212 Gear Pumps" catalogue

$$T_{max} = 1.59 \cdot \frac{45 \cdot 200}{90} + 1.59 \cdot \frac{15 \cdot 100}{90} = 159 + 26.5 = 185.5 \text{ Nm}$$

$$T_{max} = 185.5 \leq 230 \text{ Nm (splined 13T)}$$

$$T_2 = 26.5 \leq T_{imax} 200 \text{ Nm}$$

4.3.2 Tandem pumps dimensions

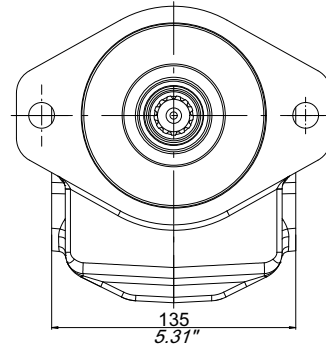
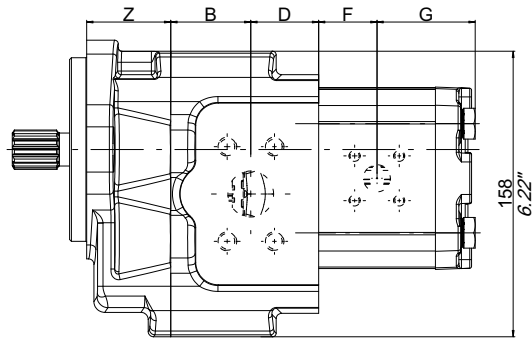
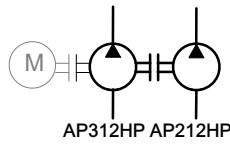

Pump size SAE-B, SAE-C	B		D		Pump size European version	B		D	
	mm	inch	mm	inch		mm	inch	mm	inch
AP312HP/40	41.3	1.63	37.5	1.48	-----	-----	-----	-----	-----
AP312HP/45	44.3	1.74	37.5	1.48	-----	-----	-----	-----	-----
AP312HP/54	50.1	1.97	37.5	1.48	AP312HP/54	50.1	1.97	37.5	1.48
AP312HP/63	55.5	2.19	37.5	1.48	AP312HP/63	55.5	2.19	37.5	1.48
AP312HP/75	63.1	2.48	37.5	1.48	AP312HP/75	63.1	2.48	37.5	1.48

Front cover dimensions	SAE-B		SAE-C 2 fixing holes		SAE-C 4 fixing holes		European	
	mm	inch	mm	inch	mm	inch	mm	inch
Z	46.5	1.83	49.5	1.95	80	3.15	50	1.97

For other covers dimensions see 3.3.1

Pump size AP212 aluminium	F		G	
	mm	inch	mm	inch
AP212/4.5	24.3	0.96	46.6	1.83
AP212/6.5	25.8	1.02	48.1	1.89
AP212/8.5	27.3	1.08	49.6	1.95
AP212/11	29.3	1.54	51.6	2.03
AP212/15	32.3	1.27	54.6	2.15
AP212/19	35.3	1.39	57.6	2.27
AP212/22	37.6	1.48	59.9	2.36
AP212/26	40.6	1.60	62.9	2.48

4.3.3 Dimensions example

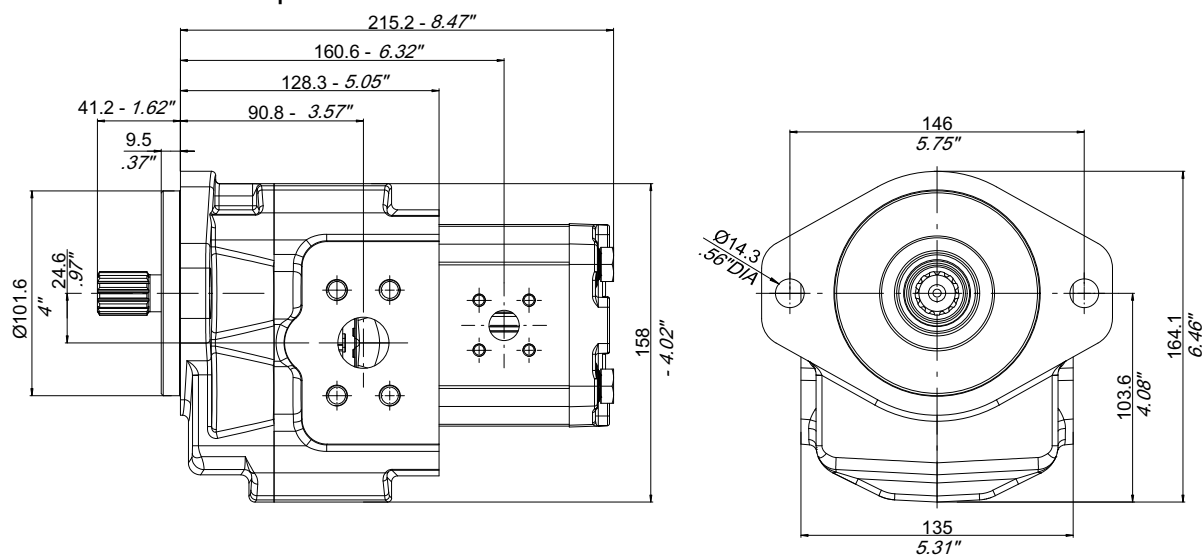

Example AP312HP/45+AP212/15 SAE-B:

Total length: $214.9 = (Z+B+D+F+G) = 46.5+44.3+37.5+32.3+54.6$

Port position: $160.6 = (Z+B+D+F) = 46.5+44.3+37.5+32.3$

$90.8 = (Z+B) = 46.5+44.3$

4.3.4 How to order triple pumps AP312HP+AP212 aluminium version

		1 st PUMP					2 nd PUMP AP212 Aluminium					1 st BODY		2 nd BODY															
1	2	3	4	5	6	7	8	9	10	11	12	13	14	15	16	17													
A	P	3	1	2	H	P	/	4	5	-	2	1	2	/	1	5	-	S	-	S	3	8	B	2	S	B	-	2	B

1 Function

AP= single gear pump - unidirectional

2 Series

312HP (Cast iron)

3 Displacement

40= 40.2 cm³/rev
45= 45 cm³/rev
54= 54.4 cm³/rev
63= 63.1 cm³/rev
75= 75.3 cm³/rev

4 Rotation

S = left-hand rotation
D = Right-hand rotation

5 Shaft end code

see section 3.2

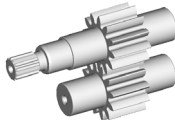

6 Front cover type

see section 3.3.1

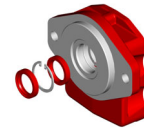

7 Type of ports code

see section 3.3.2

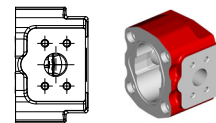

8 Inlet/outlet port size code combination

see section 3.3.2

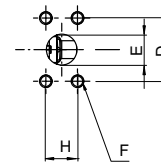

9 BHRE section : Version - Progressive number (omitted)

AP212

22 Series

212 (Aluminium)

23 Displacement

212
4.5= 4.4 cm³/rev
6.5= 6.4 cm³/rev
8.5= 8.4 cm³/rev
11= 11.1 cm³/rev
15= 15.1 cm³/rev
19= 19.2 cm³/rev
22= 22.2 cm³/rev
26= 26.2 cm³/rev

24 Version

Omitted if 12 teeth standard
LN= 12 teeth Low Noise version

27 Type of ports code

see section 3.5 AP212 Catalogue



28 Inlet/outlet port size code combination

see section 3.5 AP212 Catalogue

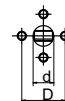

29 Body material

see section 3.5.1 AP212 Catalogue

212



30 Back cover type / Valve setting value

see section 3.6 AP212 Catalogue

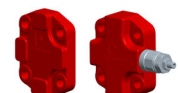

Unpainted pumps are Bucher Hydraulics standard; should a painted component be required, this feature must be specified in its purchase order.

4.4 Multiple gear pumps: AP312HP+AP312HP+AP212HP cast iron versions

(AP312HP: SAE-B and SAE-C 2 and 4 fixing holes only, no European version)

Standard versions means separated inlet/outlet side ports, without shaft seal among pump stages

4.4.1 Drive torque calculation example

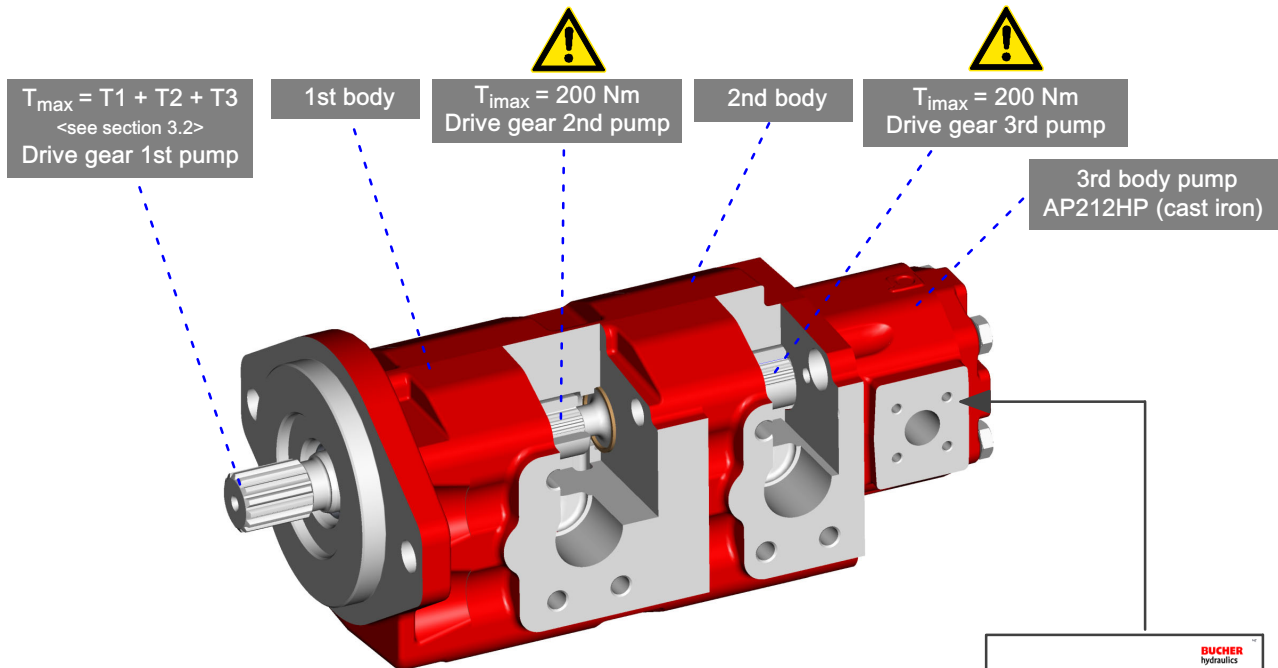

$$T_{\max} = 1.59 \cdot \frac{p_1 \cdot V_{c1}}{\eta_{m1}} + 1.59 \cdot \frac{p_2 \cdot V_{c2}}{\eta_{m2}} + 1.59 \cdot \frac{p_3 \cdot V_{c3}}{\eta_{m3}}$$

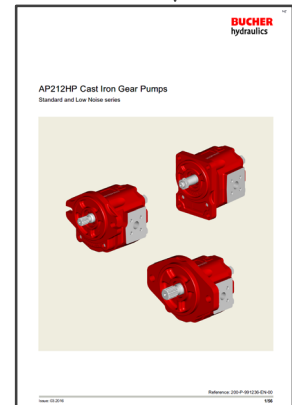

Further information regarding group 2 pumps: see dedicated "AP212HP Cast Iron Gear Pumps" catalogue

Example: AP312HP/75 + AP312HP/54 + AP212HP/15

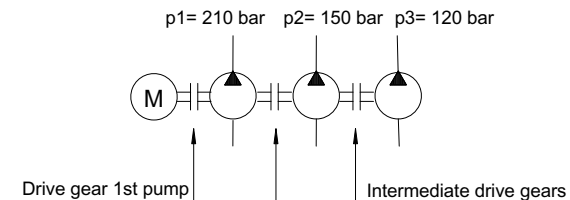

$$T_{\max} = 1.59 \cdot \frac{75 \cdot 210}{90} + 1.59 \cdot \frac{54 \cdot 150}{90} + 1.59 \cdot \frac{15 \cdot 120}{90} = 278.25 + 143.1 + 31.8 = 453.15 \text{ Nm}$$

$$T_{\max} = 453.15 \leq 950 \text{ Nm (splined 14T)}$$

$$T_2 = 174.9 \leq T_{\max} 200 \text{ Nm} \quad T_3 = 31.8 \leq T_{\max} 200 \text{ Nm}$$

Common suction versions available on request.
Please contact our Sales Department.

4.4.2 Triple/multiple pumps dimensions

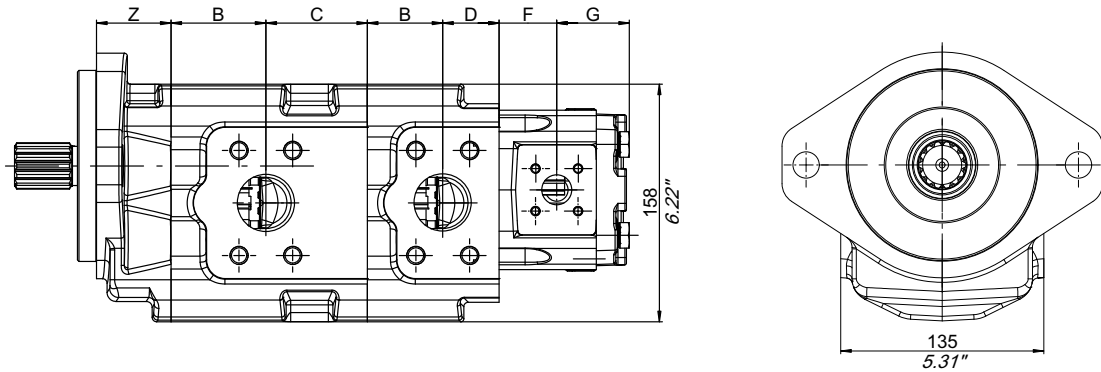
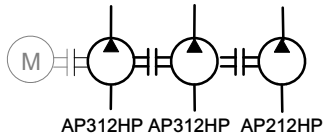

Pump size	B		C		D	
	mm	inch	mm	inch	mm	inch
AP312HP/40	41.3	1.63	-	-	37.5	1.48
AP312HP/45	44.3	1.74	-	-	37.5	1.48
AP312HP/54	50.1	1.97	-	-	37.5	1.48
AP312HP/63	55.5	2.19	67.5	2.66	37.5	1.48
AP312HP/75	63.1	2.48	67.5	2.66	37.5	1.48

Front cover dimensions	SAE-B		SAE-C 2 fixing holes		SAE-C 4 fixing holes	
	mm	inch	mm	inch	mm	inch
Z	46.5	1.83	49.5	1.95	80	3.15

For other covers dimensions see 3.3.1

Pump size AP212HP	F		G	
	mm	inch	mm	inch
AP212HP/15	38.3	1.51	48.3	1.90
AP212HP/19	41.3	1.63	51.3	2.01
AP212HP/22	43.55	1.71	55.55	2.11
AP212HP/26	46.55	1.83	56.55	2.23
AP212HP/29	48.55	1.91	58.55	2.31
AP212HP/33	51.55	2.03	61.55	2.42

4.4.3 Dimensions example

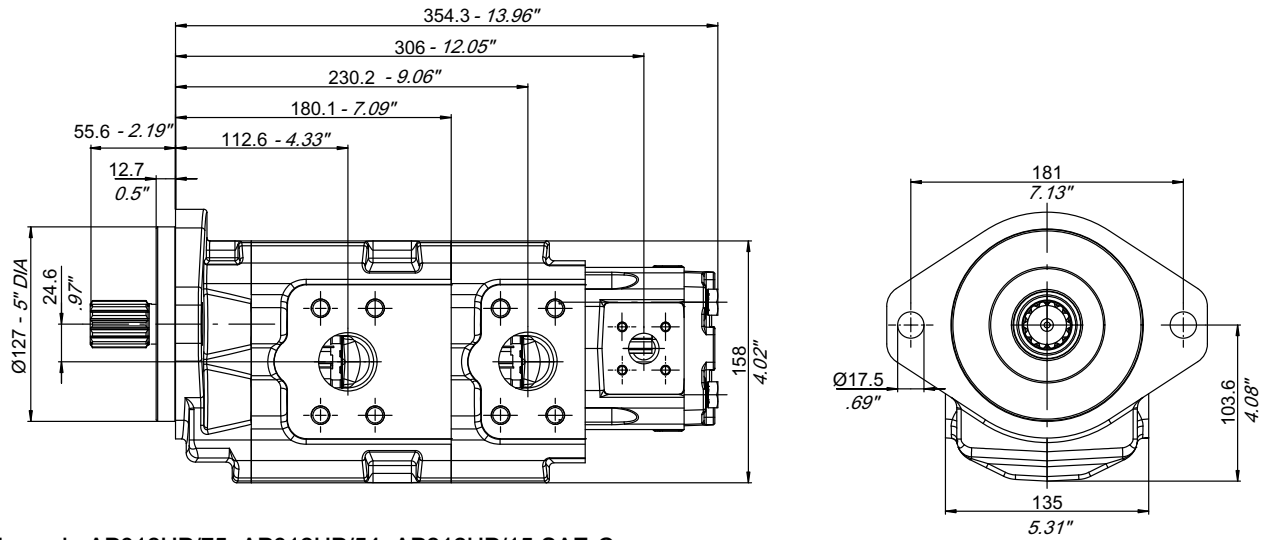

Example AP312HP/75+AP312HP/54+AP212HP/15 SAE-C:

Total length: $354.3 = (Z+B+C+B+D+F+G) = 49.5+63.1+67.5+50.1+37.5+38.3+48.3$

Port position: $306 = (Z+B+C+B+D+F) = 49.5+63.1+67.5+50.1+37.5+38.3$

$230.2 = (Z+B+C+B) = 49.5+63.1+67.5+50.1$

$112.6 = (Z+B) = 49.5+63.1$

4.4.4 How to order triple pumps AP312HP+AP312HP+AP212HP cast iron versions

1st PUMP			2nd PUMP	3rd PUMP AP212 Aluminium			1st BODY		2nd BODY		3rd BODY				
1	2		3	3	22		23	4	5	6	7	8	7	8	27
A	P	3 1 2 H P /	7 5 -	5 4 -	2 1 2 /	1 5 -	S - S	4 8 C	2 S C	-	2 S B	-	2 B		

1 Function

AP= single gear pump - unidirectional

2 Series

312HP (Cast iron)

3 Displacement

40= 40.2 cm³/rev
45= 45 cm³/rev
54= 54.4 cm³/rev
63= 63.1 cm³/rev
75= 75.3 cm³/rev

4 Rotation

S = left-hand rotation
D = Right-hand rotation

5 Shaft end code

see section 3.2

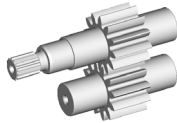

6 Front cover type

see section 3.3.1

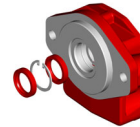

7 Type of ports code

see section 3.3.2

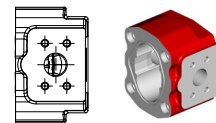

8 Inlet/outlet port size code combination

see section 3.3.2

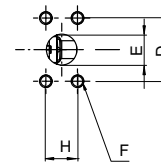

9 BHRE section : Version - Progressive number (omitted)

AP212HP

22 Series

212HP (Cast iron)

23 Displacement

212HP
15= 15.1 cm³/rev
19= 19.2 cm³/rev
22= 22.2 cm³/rev
26= 26.2 cm³/rev
29= 28.9 cm³/rev
33= 33 cm³/rev

24 Version

Omitted if 12 teeth standard
LN= 12 teeth Low Noise version

27 Type of ports code

see section 3.5 AP212HP Catalogue

212HP

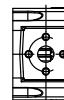

28 Inlet/outlet port size code combination

see section 3.5 AP212HP Catalogue

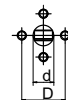

29 Body material

see section 3.5.1 AP212HP Catalogue

212HP

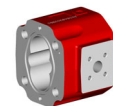

30 Back cover type / Valve setting value

see section 3.6 AP212HP Catalogue

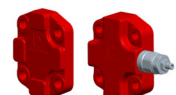

Unpainted pumps are Bucher Hydraulics standard; should a painted component be required, this feature must be specified in its purchase order.

4.5 Multiple gear pumps: AP312HP+AP312HP+AP212 aluminium version

(AP312HP: SAE-B and SAE-C 2 and 4 fixing holes only, no European version)

Standard versions means separated inlet/outlet side ports, without shaft seal among pump stages

4.5.1 Drive torque calculation example

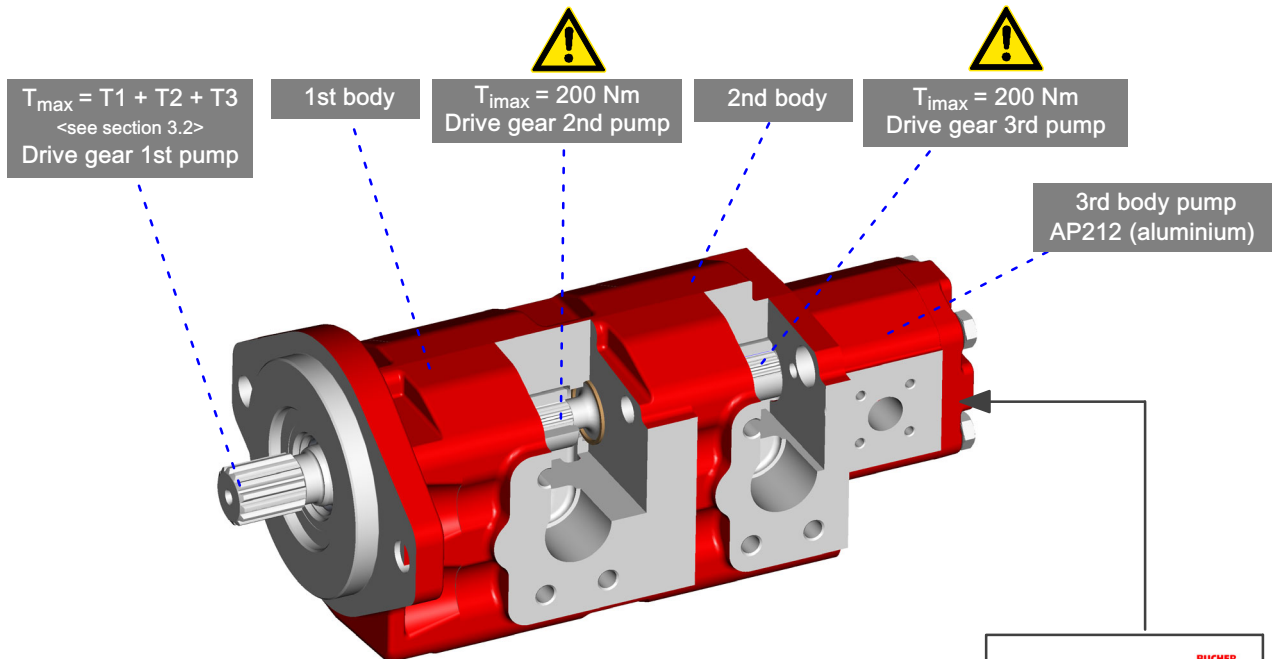

$$T_{\max} = 1.59 \cdot \frac{p_1 \cdot V_{c1}}{\eta_{m1}} + 1.59 \cdot \frac{p_2 \cdot V_{c2}}{\eta_{m2}} + 1.59 \cdot \frac{p_3 \cdot V_{c3}}{\eta_{m3}}$$



Further information regarding group 2 pumps: see dedicated "AP212 Gear Pumps" catalogue

Example: AP312HP/75 + AP312HP/54 + AP212/15

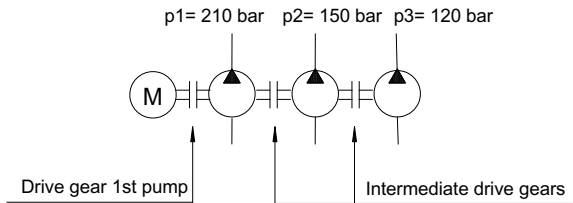

$$T_{\max} = 1.59 \cdot \frac{75 \cdot 210}{90} + 1.59 \cdot \frac{54 \cdot 150}{90} + 1.59 \cdot \frac{15 \cdot 120}{90} = 278.25 + 143.1 + 31.8 = 453.15 \text{ Nm}$$

$$T_{\max} = 444.15 \leq 950 \text{ Nm (splined 14T)}$$

$$T_2 = 174.9 \leq T_{\max} 200 \text{ Nm} \quad T_3 = 31.8 \leq T_{\max} 200 \text{ Nm}$$

Common suction versions available on request.
Please contact our Sales Department.

4.5.2 Triple/multiple pumps dimensions

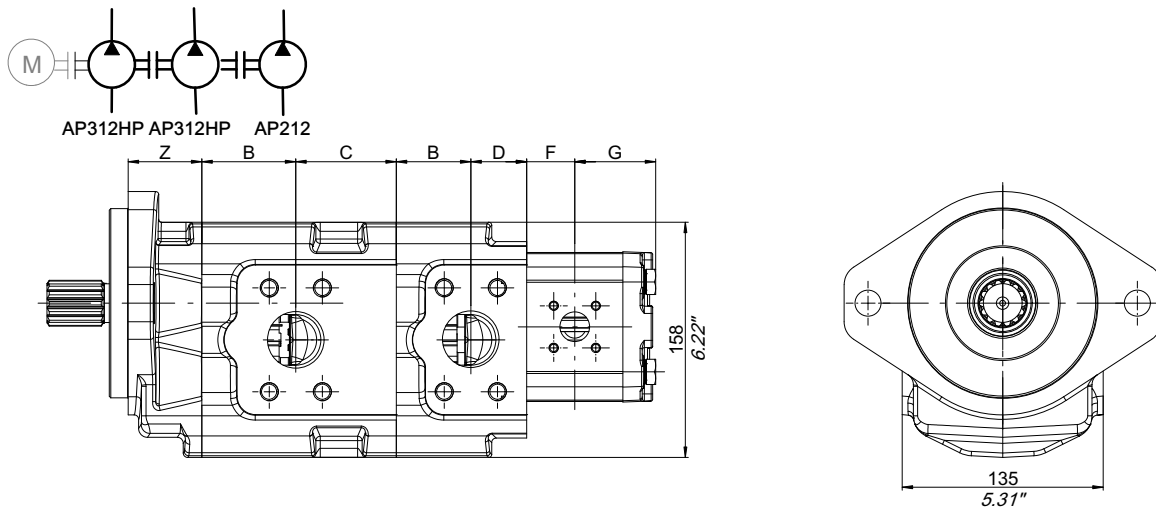

Pump size	B		C		D	
	mm	inch	mm	inch	mm	inch
AP312HP/40	41.3	1.63	-	-	37.5	1.48
AP312HP/45	44.3	1.74	-	-	37.5	1.48
AP312HP/54	50.1	1.97	-	-	37.5	1.48
AP312HP/63	55.5	2.19	67.5	2.66	37.5	1.48
AP312HP/75	63.1	2.48	67.5	2.66	37.5	1.48

Front cover dimensions	SAE-B		SAE-C 2 fixing holes		SAE-C 4 fixing holes	
	mm	inch	mm	inch	mm	inch
Z	46.5	1.83	49.5	1.95	80	3.15

For other covers dimensions see 3.3.1

Pump size AP212 aluminium	F		G	
	mm	inch	mm	inch
AP212/4.5	24.3	0.96	46.6	1.83
AP212/6.5	25.8	1.02	48.1	1.89
AP212/8.5	27.3	1.08	49.6	1.95
AP212/11	29.3	1.54	51.6	2.03
AP212/15	32.3	1.27	54.6	2.15
AP212/19	35.3	1.39	57.6	2.27
AP212/22	37.6	1.48	59.9	2.36
AP212/26	40.6	1.60	62.9	2.48

4.5.3 Dimensions example

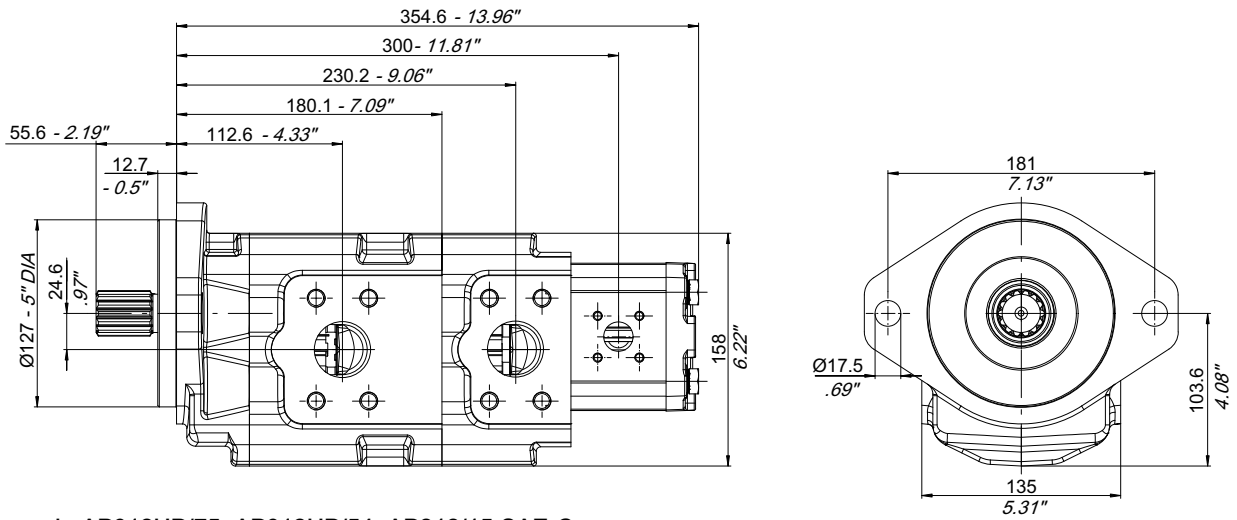

Example AP312HP/75+AP312HP/54+AP212/15 SAE-C:

Total length: $354.6 = (Z+B+C+B+D+F+G) = 49.5+63.1+67.5+50.1+37.5+32.3+54.6$

Port position: $300 = (Z+B+C+B+D+F) = 49.5+63.1+67.5+50.1+37.5+32.3$

$230.2 = (Z+B+C+B) = 49.5+63.1+67.5+50.1$

$112.6 = (Z+B) = 49.5+63.1$

4.5.4 How to order triple pumps AP312HP+AP312HP+AP212 aluminium version

1st PUMP			2nd PUMP	3rd PUMP AP212 Aluminium			1st BODY		2nd BODY		3rd BODY				
1	2		3	3	22		23	4	5	6	7	8	7	8	27
A	P	3 1 2 H P /	7 5 -	5 4 -	2 1 2 /	1 5 -	S - S	4 8 C	2 S C	-	2 S B	-	2 B		

1 Function

AP= single gear pump - unidirectional

2 Series

312HP (Cast iron)

3 Displacement

40= 40.2 cm³/rev
45= 45 cm³/rev
54= 54.4 cm³/rev
63= 63.1 cm³/rev
75= 75.3 cm³/rev

4 Rotation

S = left-hand rotation
D = Right-hand rotation

5 Shaft end code

see section 3.2

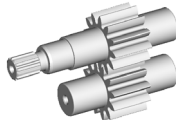

6 Front cover type

see section 3.3.1

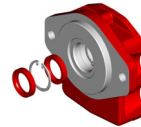

7 Type of ports code

see section 3.3.2

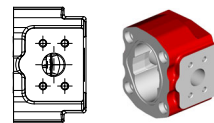

8 Inlet/outlet port size code combination

see section 3.3.2

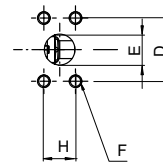

9 BHRE section : Version - Progressive number (omitted)

AP212

22 Series

212 (Aluminium)

23 Displacement

212
4.5= 4.4 cm³/rev
6.5= 6.4 cm³/rev
8.5= 8.4 cm³/rev
11= 11.1 cm³/rev
15= 15.1 cm³/rev
19= 19.2 cm³/rev
22= 22.2 cm³/rev
26= 26.2 cm³/rev

24 Version

Omitted if 12 teeth standard
LN= 12 teeth Low Noise version

27 Type of ports code

see section 3.5 AP212 Catalogue

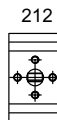

28 Inlet/outlet port size code combination

see section 3.5 AP212 Catalogue

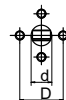

29 Body material

see section 3.5.1 AP212 Catalogue



30 Back cover type / Valve setting value

see section 3.6 AP212 Catalogue

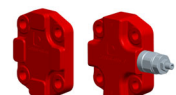

Unpainted pumps are Bucher Hydraulics standard; should a painted component be required, this feature must be specified in its purchase order.

5 Product identification plate

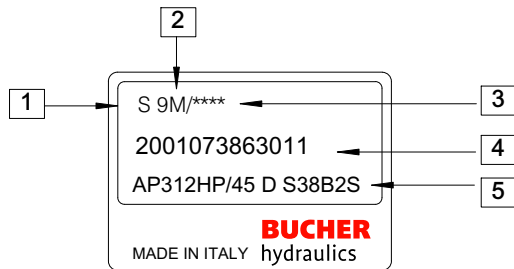

1 : Rotation (D= Clockwise rotation - S= Counterclockwise rotation)

2 : Manufacturing year and month

3 : Progressive identification no. (optional)

4 : Bucher Hydraulics S.p.A. product code

5 : Description

Manufacturing month	Manufacturing year						
	2019	2020	2021	2022	2023	2024	2025
January	9M	0M	1M	2M	3M	4M	5M
February	9N	0N	1N	2N	3N	4N	5N
March	9P	0P	1P	2P	3P	4P	5P
April	9Q	0Q	1Q	2Q	3Q	4Q	5Q
May	9R	0R	1R	2R	3R	4R	5R
June	9S	0S	1S	2S	3S	4S	5S
July	9T	0T	1T	2T	3T	4T	5T
August	9U	0U	1U	2U	3U	4U	5U
September	9V	0V	1V	2V	3V	4V	5V
October	9Z	0Z	1Z	2Z	3Z	4Z	5Z
November	9X	0X	1X	2X	3X	4X	5X
December	9Y	0Y	1Y	2Y	3Y	4Y	5Y

6 Application form

Date:			
Contact:			
Customer:			
Location:			
Overall quantity per year:			
Minimum batch size:			
Delivery time requested:	Feasibility:	Prototypes:	Series:
Target price:			
Type of application:			

External gear pump general data					
Rotation	S	D	R	Speed range	
Displacement: Single pump (cm ³ /rev)				Continuous work pressure (bar)	1st 2nd 3rd
Double pump (cm ³ /rev)	1st	2nd		Peak work pressure (bar)	1st 2nd 3rd
Multiple pump (cm ³ /rev)	1st	2nd	3rd	Oil type	
Drive shaft				Oil temperature (°C)	min max
Port type				Oil viscosity (cSt)	min max
Front cover type				Suction line pressure	
Bearing support				Voltage	
Front cover material				Drain case pressure	
Intermediate cover (with or without shaft seal)	with	without		Radial load (N)	
Back cover type/circuit				Axial load (N)	
Back cover material	aluminium	cast iron		Working hours per year	
Valves				Cycles per year	

Additional notes:

info.it@bucherhydraulics.com

www.bucherhydraulics.com

© 2020 by Bucher Hydraulics S.p.A, I-42124 Reggio Emilia

All rights reserved.

Data is provided for the purpose of product description only, and must not be construed as warranted characteristics in the legal sense. The information does not relieve users from the duty of conducting their own evaluations and tests. Because the products are subject to continual improvement, we reserve the right to amend the product specifications contained in this catalogue.

Classification: 410.110.000