

CB2D 齿轮泵

CB2D GEAR PUMPS

简介 General Description

CB2D 齿轮泵系高压小排量齿轮油泵，由一对高强度齿轮、轴套、泵体、前盖、后盖等主要部件组成，轴向间隙由高精度浮动轴套自动补偿，使得CB2D 齿轮泵具有高的机械效率和容积效率，该泵噪音低、可靠性高，低的重量 / 功率比，该泵具有顺时针，逆时针两种旋向。

The CB2D gear pump consists of a gear pair supported by two aluminum bearing blocks, a housing, front cover and rear cover. The axial clearance can be automatically compensated by the bearing blocks. The CB2D pump features simple structure, high mechanical and volumetric efficiency, low noise, high reliability as well as low weight/ power ratio. Both CW and CCW directions pumps are available.



型谱 Order Code

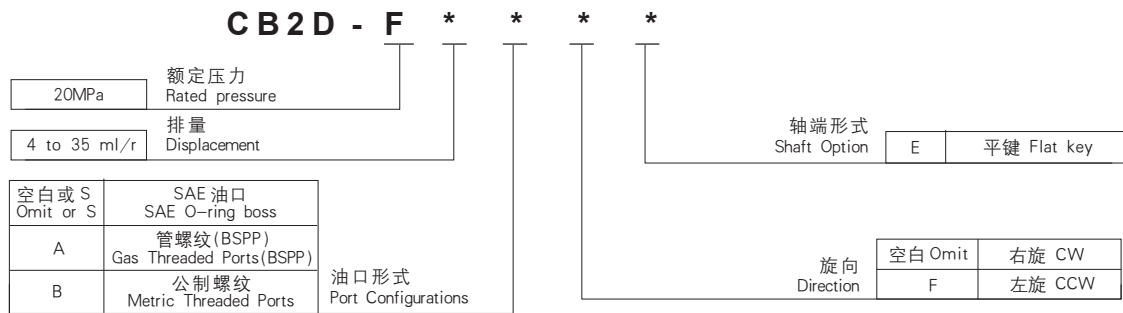

外形尺寸图 Outline Dimension

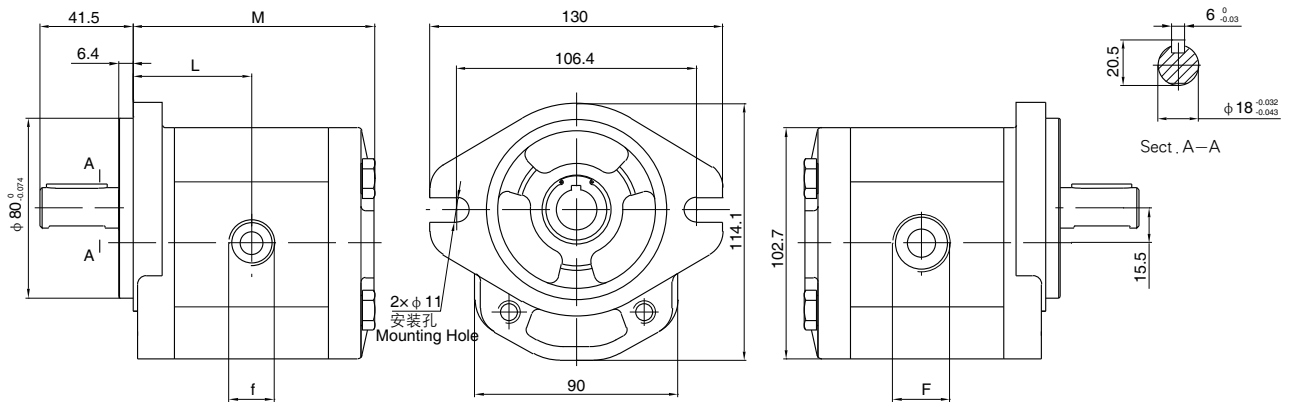

技术参数 Technical Data

Model 型号	Displacement 排量 mL/r(in ³ /r)	压力 Pressure			转速 Speed		尺寸 Dimension				
		P1 MPa	P2 MPa	P3 MPa	额定 Rated RPM	最高 Max RPM	L mm	M mm	F 进油口 Inlet	f 出油口 Outlet	
CB2D-F4 ***	4.47 (0.273)	20	25	28	2000	4000	45.6	93.2	SAE port 1 1/8"-12UN	SAE port 7/8"-14UN	
CB2D-F6 ***	6.37 (0.389)						47.1	96.3			
CB2D-F7 ***	7.04 (0.428)						47.7	97.4			
CB2D-F9 ***	9.55 (0.584)						49.6	101.3			
CB2D-F11 ***	11.49 (0.701)						51.3	104.6			
CB2D-F14 ***	14.04 (0.857)						53.4	108.9			
CB2D-F15 ***	15.92 (0.973)				1500	1800	2800	54.9	111.9	BSPP port G3/4" 公制口 Metric port M27X2	BSPP port G1/2" 公制口 Metric port M22X2
CB2D-F17 ***	17.76 (1.090)						2500	56.4	114.9		
CB2D-F21 ***	21.07 (1.285)						2200	59.1	120.3		
CB2D-F23 ***	23.27 (1.441)						2000	60.9	123.9		
CB2D-F28 ***	28.07 (1.713)	15	17	19	1800	64	131.7	1 1/8"-12UN G1" M33X2	1 1/8"-12UN G3/4" M27X2		
CB2D-F32 ***	32.02 (1.954)					68.1	138.2				
CB2D-F35 ***	35.08 (2.141)					70.6	143.2				