

简介 General Description

CBK 齿轮泵系高压小排量齿轮油泵，由一对高强度齿轮、轴套、泵体、前盖、后盖等主要部件组成，轴向间隙由高精度浮动轴套自动补偿，使得CBK 齿轮泵具有高的机械效率和容积效率，该泵噪音低、重量功率比小，广泛应用各种交流和直流液压力单元和中小型液压系统。

用户订货时应注意，CBK 齿轮泵有顺时针、逆时针两种转向及后盖进/前盖出、泵体进/后盖出、后盖进/泵体出、泵体进/泵体出、后盖进/后盖出五种进出油方式。

The CBK gear pump consists of a gear pair supported by two aluminum bearing blocks, a housing, front cover and rear cover. The axial clearance can be automatically compensated by the bearing blocks. The CBK pump features high mechanical and volumetric efficiency, low noise level as well as low weight/power ratio.

Notes: The CBK gear pump has five options of inlet/outlet positions: rear in/front out, side in/rear out, rear in/side out, side in/side out, rear in/rear out. Both CW and CCW direction pumps are available.



型谱 Order Code

CBK - F * * * * *

20MPa	额定压力 Rated pressure				
0.63 ~ 8 mL/r	排量 Displacement				
D	后盖进 / 后盖出 Rear in / rear out				
C	泵体进 / 泵体出 Side in / side out				
B	后盖进 / 泵体出 Rear in / side out				
A	泵体进 / 后盖出 Side in / rear out				
空白 Omit	后盖进 / 前盖出 Rear in / front out	进出油位置 Inlet/outlet Position			
			轴端形式 Shaft Optional	空白 Omit	扁势 Tang
				D	花键 Spline
			旋向 Direction	空白 Omit	顺时针 CW
				F	逆时针 CCW
			油口形式 Port Configurations	空白 Omit	NPT 油口 NPT O-ring boss
				G	管螺纹 Gas Threaded Ports

外形尺寸图 Outline Dimension

CBK-F*F Outline Dimension (Rear in/front out)

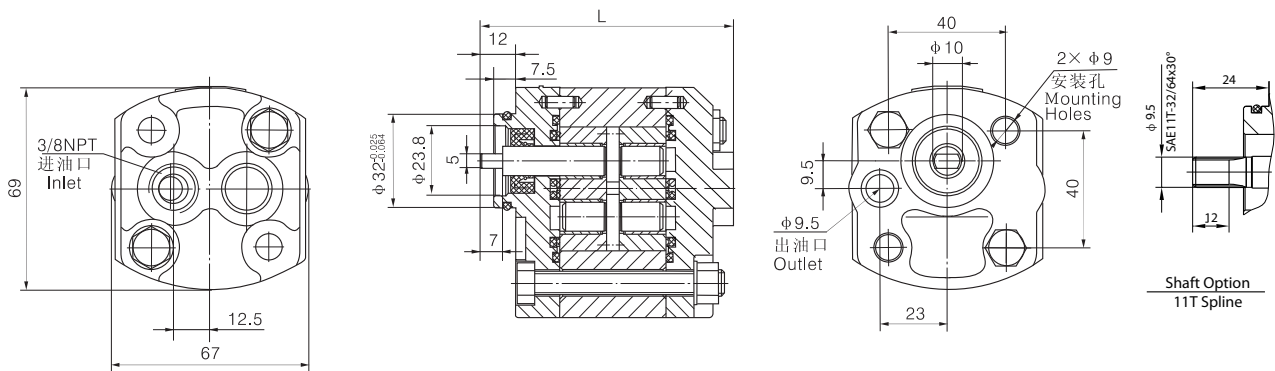

CBK-F*AF Outline Dimension (Side in/rear out)

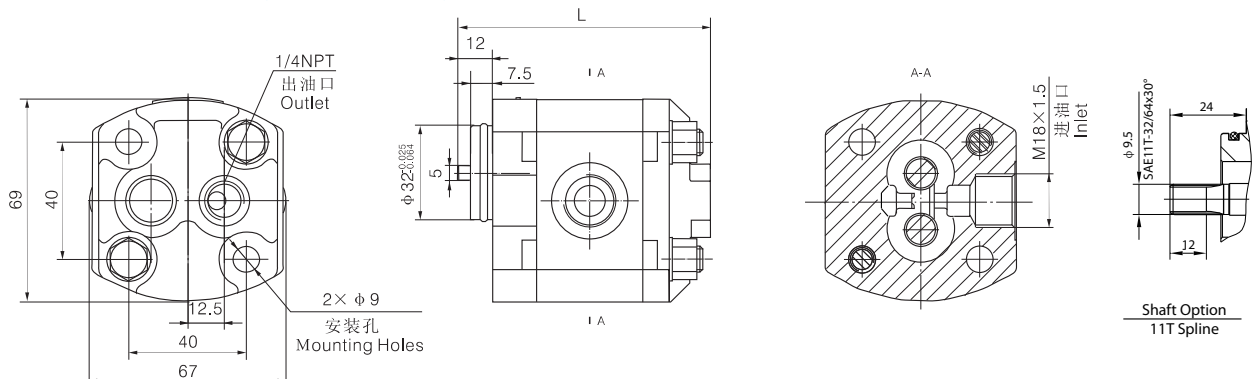

CBK-F*B Outline Dimension (Rear in/side out)

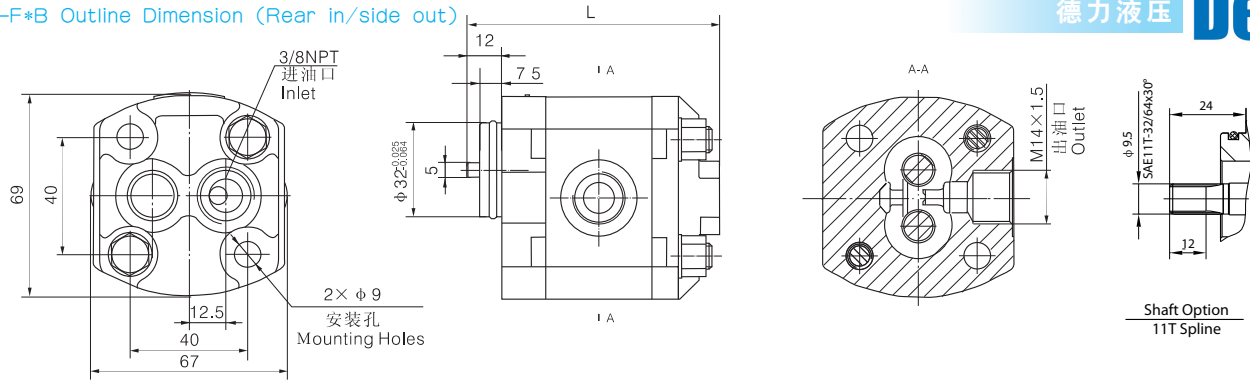

CBK-F*CF Outline Dimension (Side in/side out)

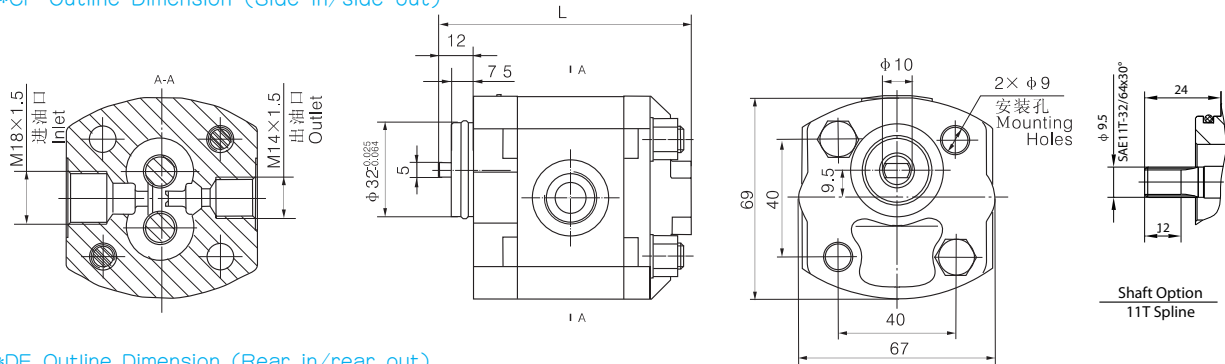

CBK-F*DF Outline Dimension (Rear in/rear out)

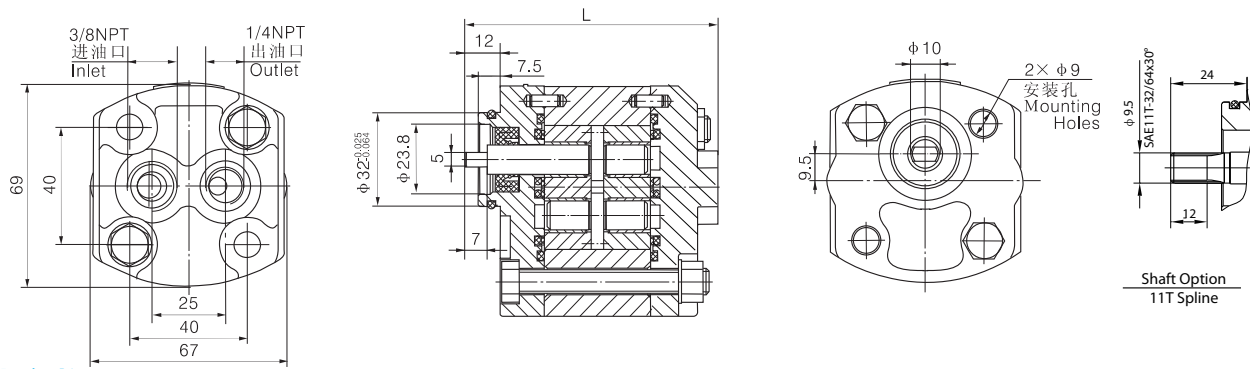

技术参数 Technical Data

Model 型号	Displacement 排量 mL/r(in ³ /r)	压力 pressure (MPa)			转速 Speed (RPM)		L(mm)	Efficiency 容积效率
		P1	P2	P3	Rated 额定	Max 最高		
CBK-F0.63**	0.63 (0.038)	20	25	28	2000	4000	84.5	85%
CBK-F0.8**	0.89 (0.054)						85.5	
CBK-F1.2**	1.27 (0.078)						87	
CBK-F1.5**	1.487 (0.091)						87.8	86%
CBK-F1.6**	1.66 (0.101)						88.5	
CBK-F2.0**	2.05 (0.125)						90	
CBK-F2.1**	2.17 (0.132)						90.5	88%
CBK-F2.5**	2.56 (0.156)						92	
CBK-F2.7**	2.8 (0.171)						93	
CBK-F3.2**	3.32 (0.203)						95	89%
CBK-F3.7**	3.8 (0.232)	18	23	26	2000	3600	97	
CBK-F4.2**	4.3 (0.263)	14	18	23	1500	3000	99	
CBK-F5**	5.1 (0.311)	10	14	18	1500	3000	102	90%
CBK-F6**	6.03 (0.368)						105.5	
CBK-F8**	8.08 (0.493)						113.5	