

CBKA-F*B Outline Dimension (Rear in/side out)

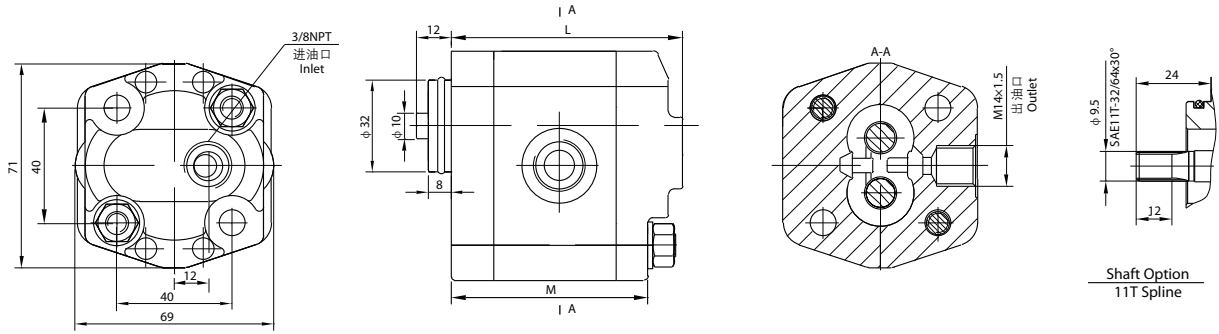

CBKA-F*CF Outline Dimension (Side in/side out)

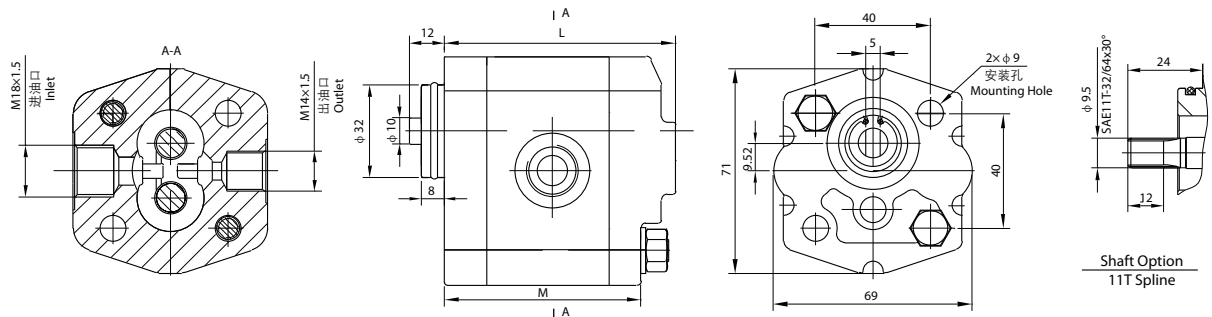

CBKA-F*DF Outline Dimension (Rear in/rear out)

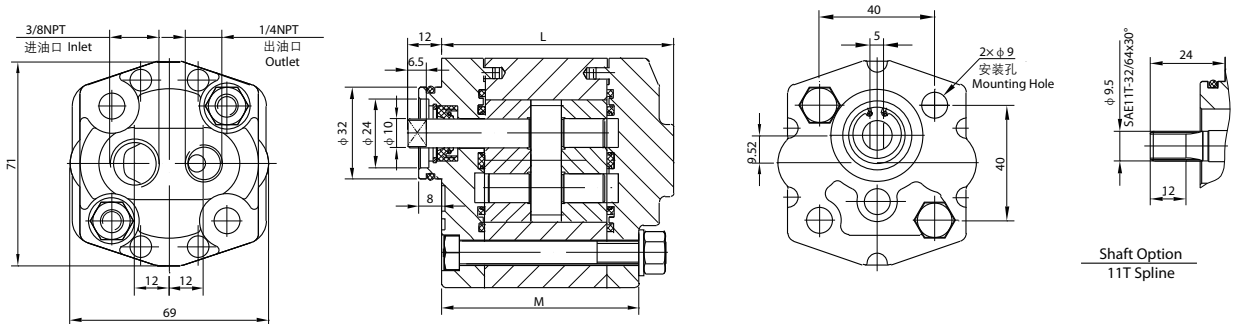

技术参数 Technical Data

Model 型号	Displacement 排量 mL/r(in ³ /r)	压力 pressure (MPa)			转速 Speed (RPM)		尺寸 Dimension		Efficiency 容积效率
		P1	P2	P3	Rated 额定	Max 最高	L(mm)	M(mm)	
CBKA-F0.63**	0.66(0.040)	20	25	28	2000	4000	72.5	60.5	85%
CBKA-F0.8**	0.87(0.053)						73.3	61.3	
CBKA-F1.2**	1.27(0.077)						74.8	62.8	
CBKA-F1.6**	1.66(0.101)						76.3	64.3	86%
CBKA-F2.1**	2.11(0.129)						78	66	
CBKA-F2.5**	2.51(0.153)						79.5	67.5	
CBKA-F2.7**	2.77(0.169)						80.5	68.5	88%
CBKA-F3.2**	3.17(0.193)	82	70						
CBKA-F3.7**	3.7(0.225)	84	72						
CBKA-F4.2**	4.23(0.258)	18	23	26	2000	3600	86	74	90%
CBKA-F5**	5.0(0.305)						89	77	
CBKA-F6**	6.0(0.366)						93	81	
CBKA-F8**	8.0(0.488)	10	14	18	1500	3000	100.5	88.5	