

简介 General Description

CBM 齿轮油泵采用高强度的压铸铝合金制成的前、后盖和粉末冶金泵体、高强度齿轮和轴，结构简单合理，且该齿轮泵具有体积小、重量轻、效率高、噪音低和寿命长等优点。适用于扫雪车液压动力单元和各种小型的中高压液压系统。

The CBM gear pump consists of a gear pair, a housing, a front cover and a rear cover. The CBM Gear Pump features high mechanical and volumetric efficiency, low noise level as well as low weight/power ratio. It is widely used in the power units for snow plows and small displacement, medium pressure hydraulic systems.



型谱 Order Code

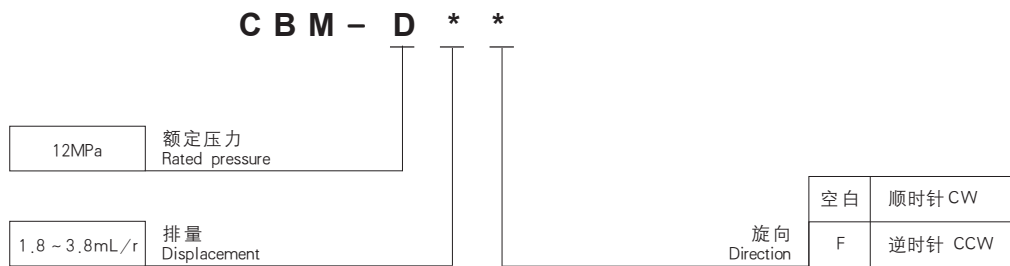

外形尺寸图 Outline Dimension

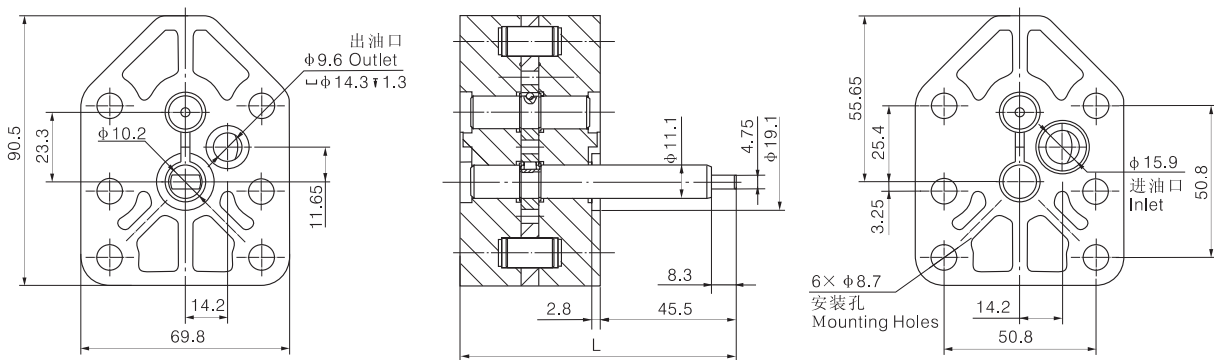

技术参数 Technical Data

Model 型号	Displacement 排量 mL/r (in ³ /r)	压力 pressure (MPa)			转速 Speed (RPM)		L(mm)	Efficiency 容积效率
		P1	P2	P3	额定 Rated (RPM)	最高 Max (RPM)		
CBM-D1.8F	1.8 (0.110)	12	15	17.5	2000	3000	92.5	75%
CBM-D2.8F	2.8 (0.171)						95.5	
CBM-D3.8F	3.8 (0.232)						98.5	