



## Electro-Motor-Pumps ET

PO Box 38  
Strathfieldsaye, VIC, 3551  
1800 OIL SOL  
1800 645 765

[sales@oilsolutions.com.au](mailto:sales@oilsolutions.com.au)

[www.oilsolutions.com.au](http://www.oilsolutions.com.au)

"For All Your Hydraulic Needs"

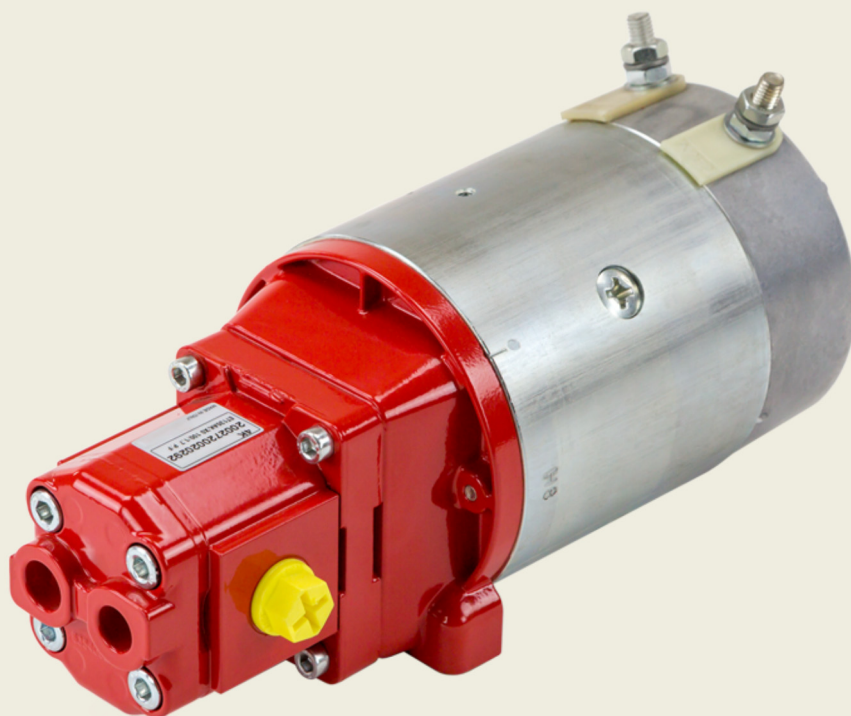

Contents		page
1	General information	3
2	D.C. Electric motors	3
3	Gear pumps	6
4	Starter relays	6
5	Electro-Motor-Pumps for group 05 pumps	7
6	D.C. Electric motors for group 05 pumps	8
7	Drive and connecting flange for group 05 pumps	12
8	Group 05 gear pumps	13
9	Electro-Motor-Pumps for group 1 pumps	15
10	D.C. Electric motors for group 1 pumps	16
11	Drives and connecting flange for group 1 pumps	22
12	Group 1 gear pumps	23
13	Group 2 gear pumps	28
14	Components	29
15	Order designation examples of Electro-Motor-Pumps	30

## 1 General information

Electro-motor-pump is the simplest and more compact unit able to supply hydraulic power, as flow and pressure, to oil-dynamic actuators.

The Electro-motor-pumps are largely used on industrial operating machines particularly on mobile machines, where, through simple valves and hoses connections it makes possible to operate and control different hydraulics actuators.

In the present technical catalogue the most common versions, obtained as combination of DC motors and External Gear Pumps, either 05 (AP05) and 1 (AP100) group, are shown, although, many and different customised versions have been designed and realised in order to satisfy to specific and dedicated customer' requests.

## 2 D.C. Electric motors

### 2.1 Technical information

Versions:

Available voltage: 12-24 V D.C.

Available power rating: 0.8 - 3 kW.

For other input voltage and power rating, consult our Sales Department.

Direction of rotation:

Unless otherwise stated, all motors are specified clockwise rotation, suitable for driving counterclockwise pumps.

### Directives and standards

- Atex:

The equipment and protective systems of these catalogue ARE NOT intended for use in potentially explosive atmospheres that is to say where there is an explosive atmosphere referred to in Article 2 of the Directive 99/92/EC and referred to Article 1.3 of the Directive 94/9/EC.

- ISO 9001: 2000

Bucher Hydraulics S.p.A. is certified for research, development and production of directional control valves, power units, gear pumps and motors, electro pumps, cartridge valves and integrated operating blocks for hydraulic applications.

Type of winding:

D.C. motors can be manufactured with different types of field windings:

- Permanent magnets
- Series
- Compound

**Permanent magnets**

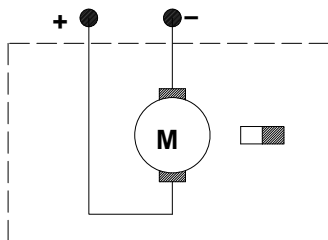

**Series**

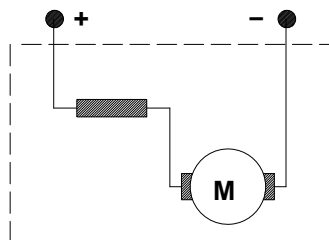

**Compound**

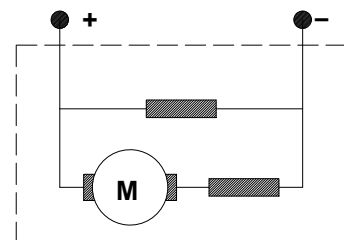

Insulation class:

The class of electric insulation reflects the maximum temperature motor can register during operation without damage to the insulating material internally of motor itself.

The following table indicates insulation classes to CEI 15-26.

Class	Y	A	E	B	F	H
Temperature (°C)	90	105	120	130	155	180

Type of duty:

To ensure selection of the electric motor best suited to a given set of operating conditions, the duty cycle needs to be verified. Duty cycles S1, S2 and S3 are defined below in accordance with CEI 2-3

cordance with CEI 2-3

Continuous duty S1:

Operation on-load (Steady conditions) for a period of indefinite duration, during which the motor reaches thermal equilibrium without exceeding the maximum permissible temperature.

Short time duty S2

Operation on-load (steady conditions) for a period of limited duration, denoted  $t_d$ , during which maximum permissible temperature is reached, followed by an off-load period of duration sufficient for the temperature of the motor to return to ambient temperature.

Intermittent duty S3

A sequence of identical cycles, each 10 minutes in duration, the single cycle comprises a period of operation on-load ( $t_d$ ), during which the motor may reach its maximum permissible temperature followed by an off-load period of limited duration ( $t_m$ ), insufficient for the temperature of the motor to return to ambient temperature. The value of S3

indicates the duration of the on-load period ( $t_d$ ) in relation to the overall cycle time ( $t_p$ ), as a percentage.

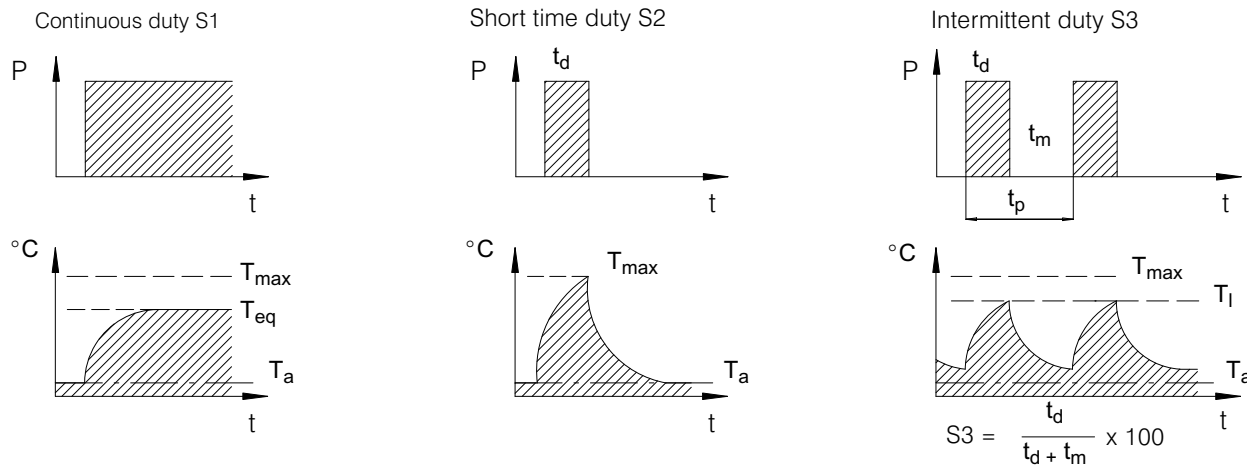

$P$  = load  
 $T_{eq}$  = temperature at thermal equilibrium  
 $T_{max}$  = maximum permissible temperature  
 $T_I$  = operating temperature

$T_a$  = ambient temperature  
 $t_d$  = duration of on-load period  
 $t_m$  = duration of off-load period  
 $t_p$  = duration of cycle (10 min.)

**Protection degree:**  
 This indicates the level of protection afforded in preventing contact between live parts of the motor and people or foreign matter generally, and preventing the penetration

of water.  
 The degree of protection is indicated in accordance with CEI 2-16 by the initials IP and two identifying digits:  
 Example:

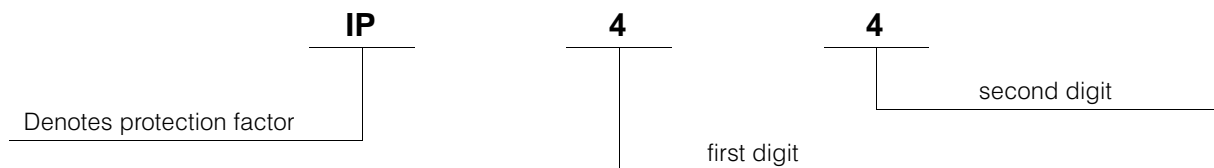

The first digit indicates the degree of protection afforded to the motor against contact with people or foreign bodies.

0	no protection
1	protection against solid particles measuring > 50 mm
2	protection against solid particles measuring > 12 mm
3	protection against solid particles measuring > 2.5 mm
4	protection against solid particles measuring > 1 mm
5	protection against dust

The second digit indicates the degree of protection afforded to the motor against the effects of penetration by water.

0	no protection
1	protection against water dripping vertically
2	protection against water dripping at 15° max
3	protection against rain
4	protected against water splash
5	protected against water spray

The degree of protection indicated for each individual electric motor refers to the motor when mounted to a Bucher Hydraulics S.p.A. electro-motor-pump.

## 2.2 Characteristic curves

Characteristic curves are given for each motors, from which to establish pressure, flow rate and current

consumption values, and S2 and S3 duty cycles.

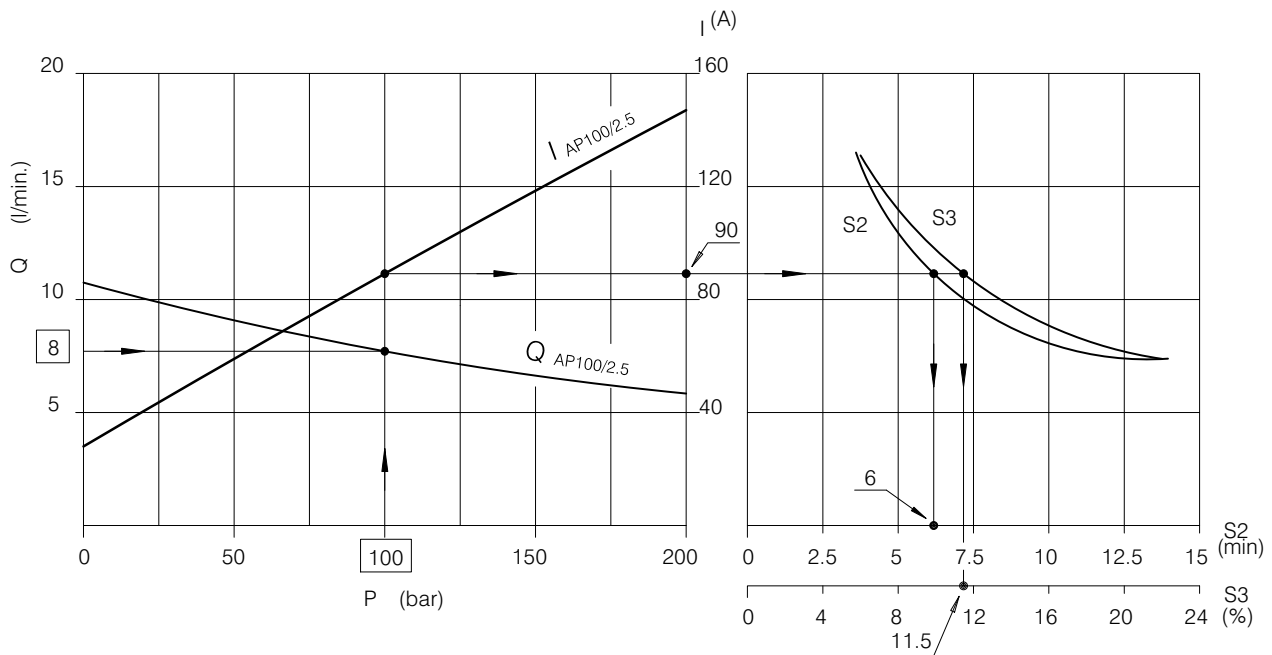

## 2.3 Example of how the graphs are used

Required data

Flow rate  $Q = 8$  l/min  
Pressure  $p = 100$  bar

Pump displacement

Determined by the intersection of the required  $p$  and  $Q$  curves.

In the example indicated, pump AP100/2.5 has the required  $p$  and  $Q$  specifications.

In the event that there is no point of intersection with any curve, a displacement as near as possible to the required flow rate should be selected.

Current consumption

This is determined by taking a vertical line from the pressure value to its point of intersection with the  $I$  curve corresponding to the selected displacement.

In the example illustrated, current consumption is:  
 $I = 90$  Ampere

Type of use

Having established the current, the relationship of the  $S_2$  and  $S_3$  curves will give the following values:

$S_2 = 6$  min.  $S_3 = 11.5\%$

## 2.4 Mounting directions

The tie bolts must not be withdrawn completely when fitting motors, but retracted a short distance (30-50 mm max).

Once fitted to the electro-motor-pump, the motor should be run off-load momentarily (5 seconds max) to verify its correct operation: supply power to the windings and measure the current drain, which must not exceed the following values:

24 V motor -  $I < 35$  Ampere  
12 V motor -  $I < 70$  Ampere

Power cable

The wire selected for power connections must be of cross section appropriate for the rated current of the motor.

Tightening torques

When assembling the motor and power pack and securing the wires of the power cable to the motor terminals, observe the tightening torque values indicated.

Brush life

The brushes will wear down progressively with continued operation of the motor, and must be replaced when reduced to their minimum useful length.

Since the rate of wear on the brushes is dictated by the operating conditions and cannot therefore be broadly specified, consult our Sales Department for guidance.

## 3 Gear pumps

### 3.1 Suitable fluids

Only mineral oil based hydraulic fluids responding to ISO/DIN standard should be used.

Viscosity range:

recommended 20 - 120 mm<sup>2</sup>/s (cSt)

permissible up to 700 mm<sup>2</sup>/s (cSt)

Operating temperature range: -15 +80 °C

For other fluids consult our Sales Department.



**Attention:** Use of pumps at temperatures above 80°C must always be agreed upon with our Technical Office, and in any case this can cause a significant worsening in the volumetric efficiency.

For use under conditions different from those indicated in this catalogue, please contact our Sales Department.

### 3.2 Inlet

Absolute pressure at the pump inlet must be

$V > 0.75$  bar (11 PSI)

Accordingly, avoid:

- significant differences in height of pump and tank
- long pipeline runs
- sharp bends, restrictions, etc. causing turbulent flow

In certain applications, inlet pressure may be higher than 1 bar (14.3 PSI), or at any rate higher than atmospheric.

For pumps with standard configuration, the pressure registering at the gauge M1 should be:

$M1 < 3.5$  bar (50 PSI).

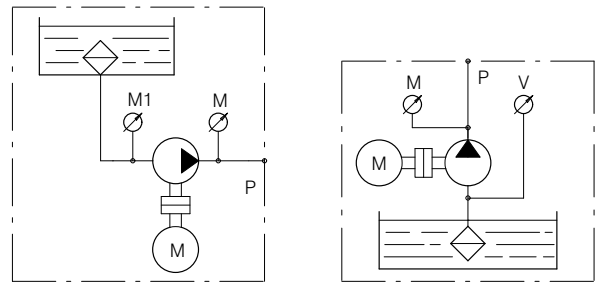

### 3.3 Outlet

Pressure levels:

P1 = continuous operating pressure

P2 = intermittent operating pressure

P3 = peak pressure

The recommended delivery pipe oil speed is between:  $v = 2 - 5$  m/s

In the next pages are indicated the performances for each pump.

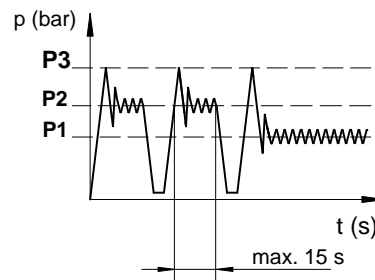

## 4 Starter relays

Technical information

**Versions:**

Available voltages: 12-24 V D.C.

Heavy duty: for more arduous conditions

See relative table for technical data

**Contact life:**

The contacts of the relay will wear down progressively during operation.

Since the rate of wear is dedicated by the type of duty and cannot therefore be broadly specified, consult our Sales dept. for guideline information.

**Fitment to electric motor**

Starter relays can be fitted to the frame of the motor by two different methods:

### 1. Direct

The relay is secured with screws, using holes already tapped in motor frame. In this instance there is one standard mounting position only.

### 2. Metal clip

The relay is secured by means of a clip encircling the motor frame and inserted through special slots in the feet of the relay itself.

In this instance, several mounting positions are possible.

### Electric diagram

A typical arrangement for connection of the relay to the electric motor is shown in the diagram.

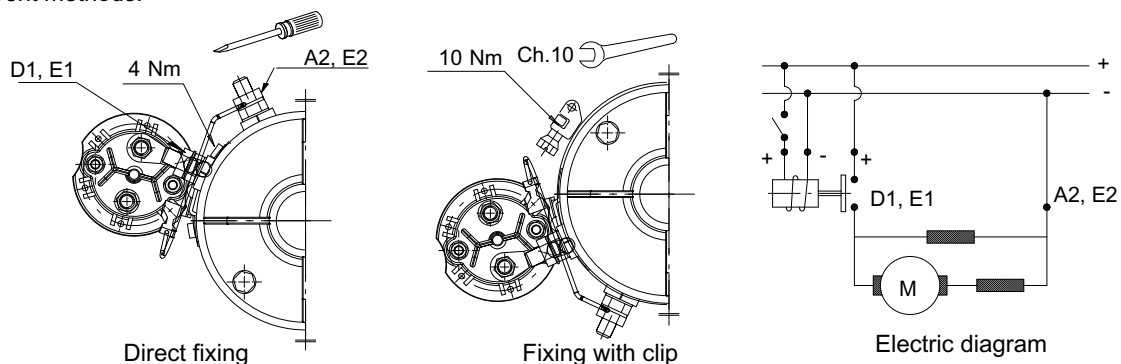

Heavy duty (STANDARD for wide range of DC el. motors)

Weight: 0.366 kg

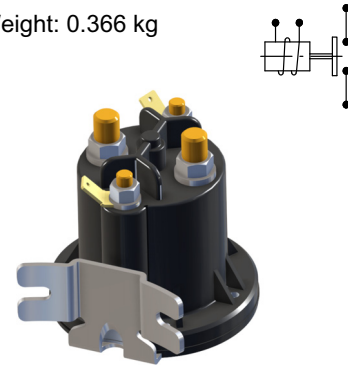
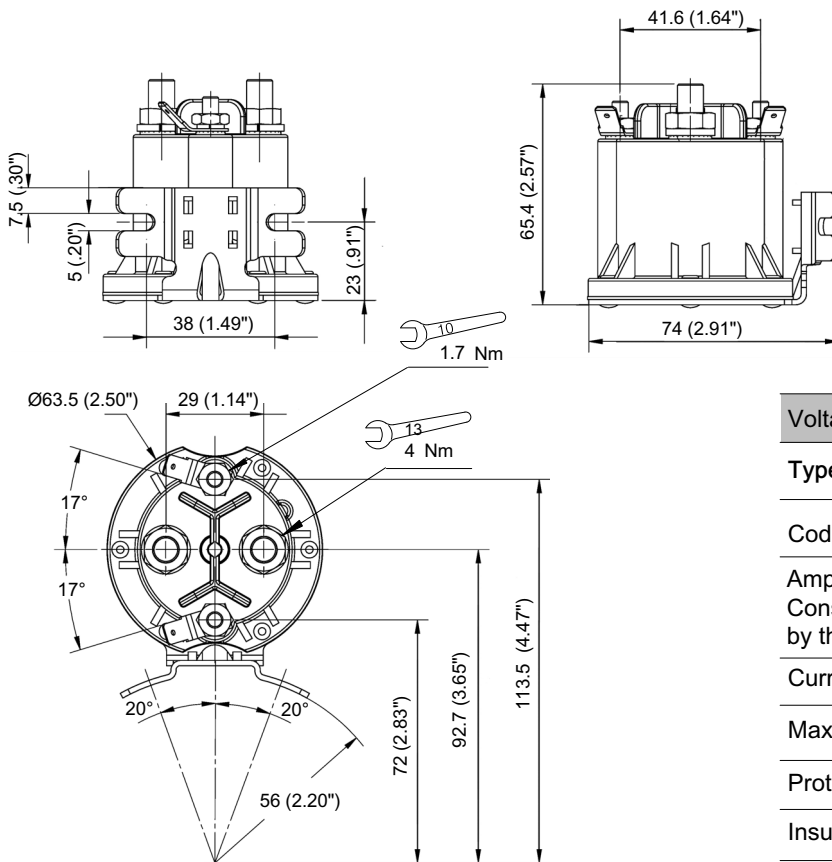

Voltage	12 V	24 V
Type	R109	R215
Code	200544134109	200544134215
Amps Consumption by the coil	2.2 A	1.2 A
Current for continuous duty		150 A
Max. current (5 sec.)		800 A
Protection index		IP66
Insulation class		F

## 5 Electro-Motor-Pumps for group 05 pumps

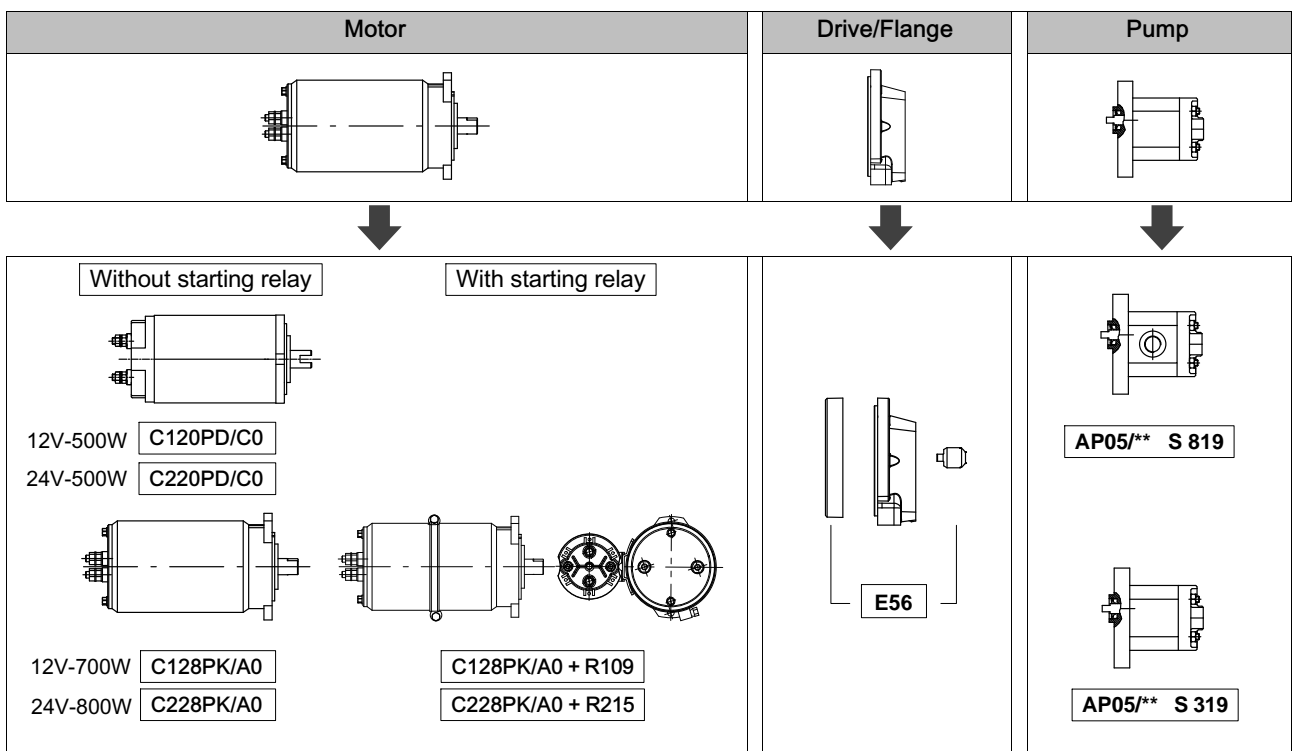

## 6 D.C. Electric motors for group 05 pumps

Voltage	12 V	24 V
Nominal Power	500 W	500 W

Protection index: ..... IP54  
 Insulation class: ..... F  
 Type of winding: ..... Permanent magnets

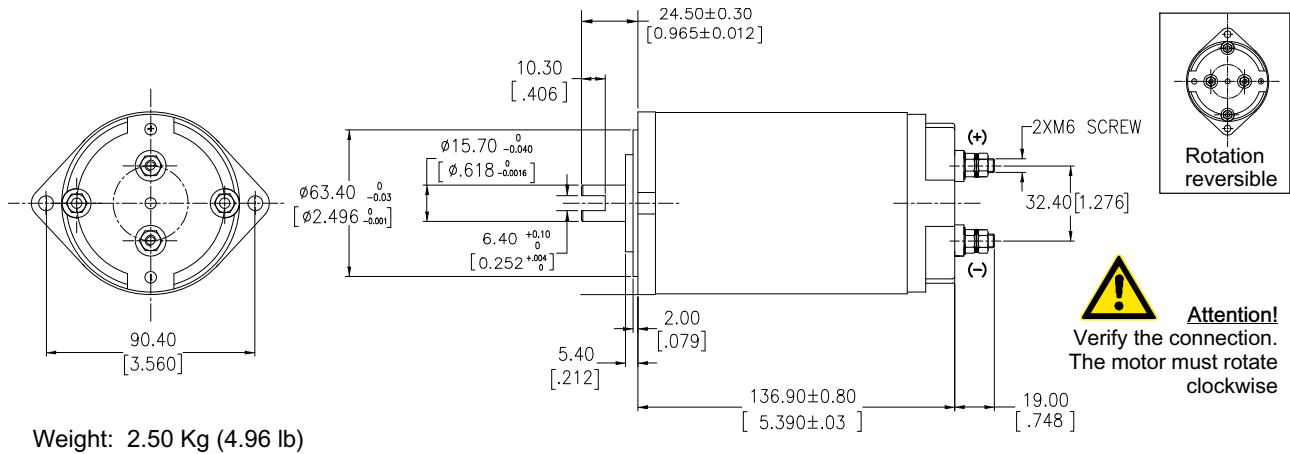

	Motor		Motor with relay	
Rotation Reversible				
Type	C120PD/C0	C220PD/C0		
Code	200543912003	200543922004		
Relay				
Relay type				

### Motor mounting position

Standard positions

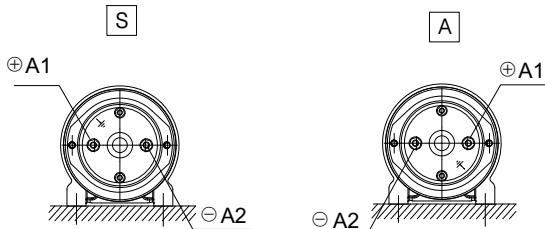

## 12 V - 500 W

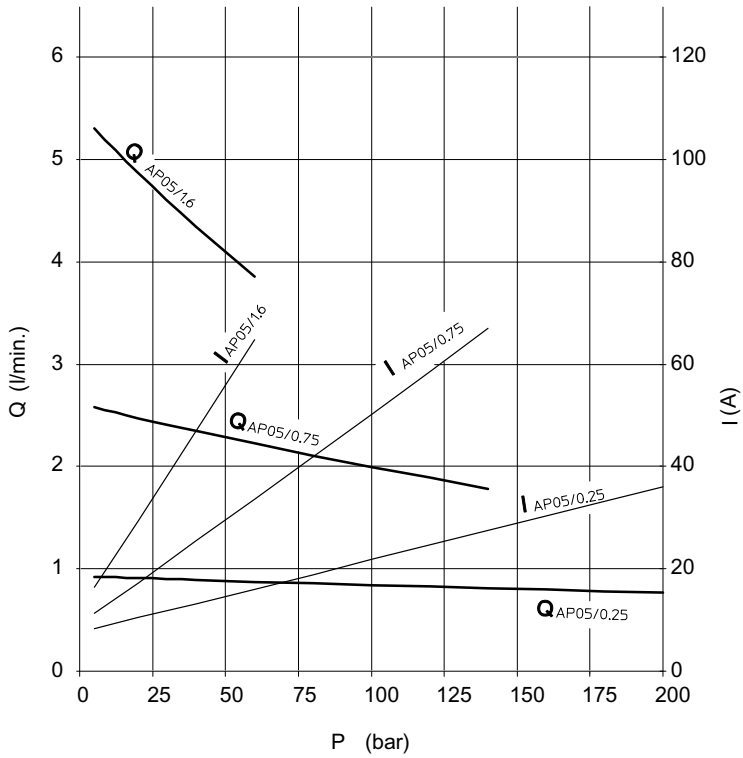

## 24 V - 500 W

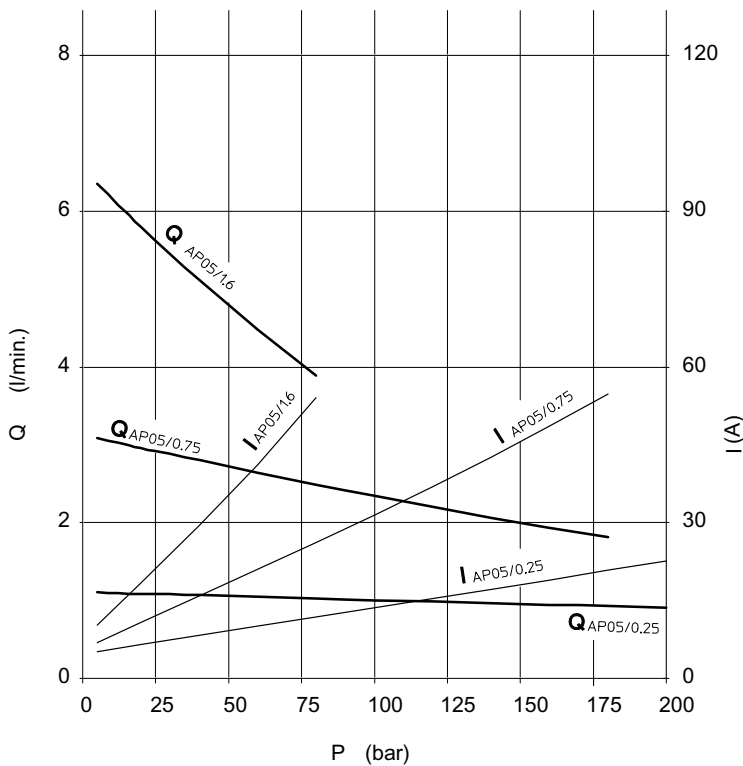

Voltage	12 V	24 V
Nominal Power	800 W	800 W

Protection index: ..... IP54  
 Insulation class: ..... F  
 Type of winding: ..... Permanent magnets  
 Relay fixing kit ..... 200709000090  
 Minimum brushes length: ..... 5 mm (0.2 inches)

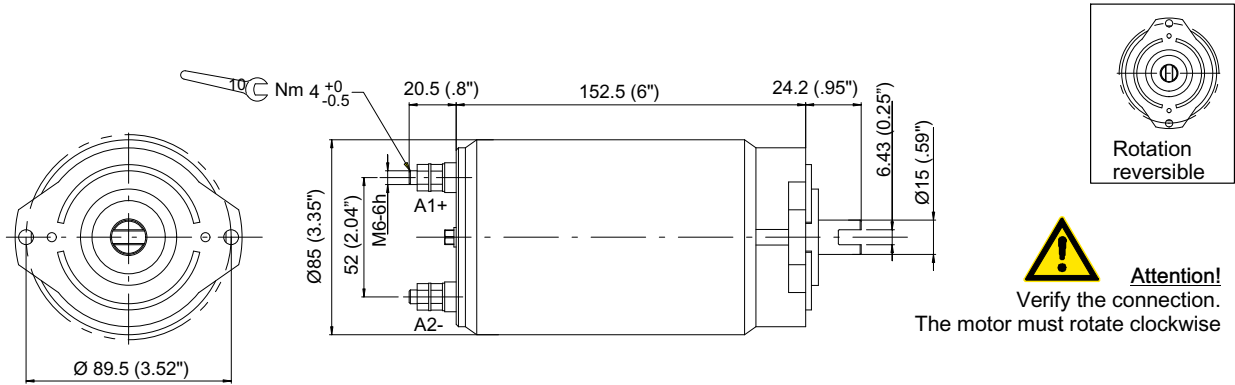

Weight: 3.70 Kg (8.15 lb)

	Motor		Motor with relay			
Rotation reversible						
Type	C128PK/A0	C228PK/A0	C128PK/A0 + R109	C228PK/A0 + R215		
Code	200543912809	200543922801	200763310270	200763320300		
Relay			STANDARD			
Relay type			R109	R215		

### Motor mounting position

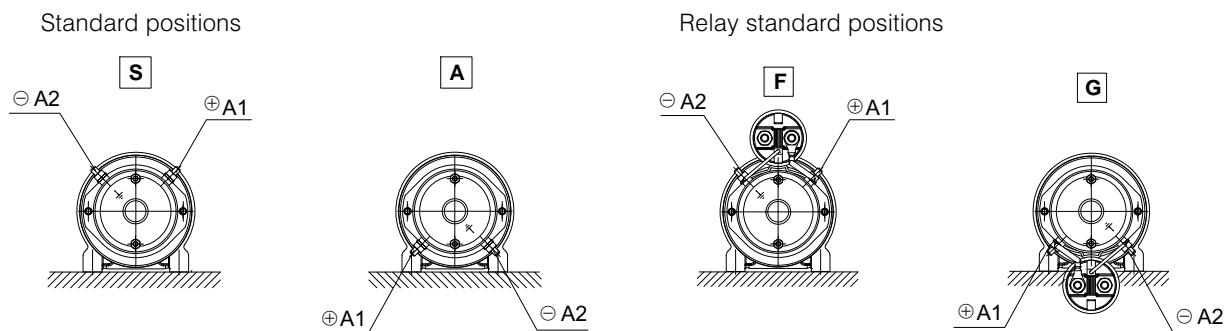

## 12 V - 800 W

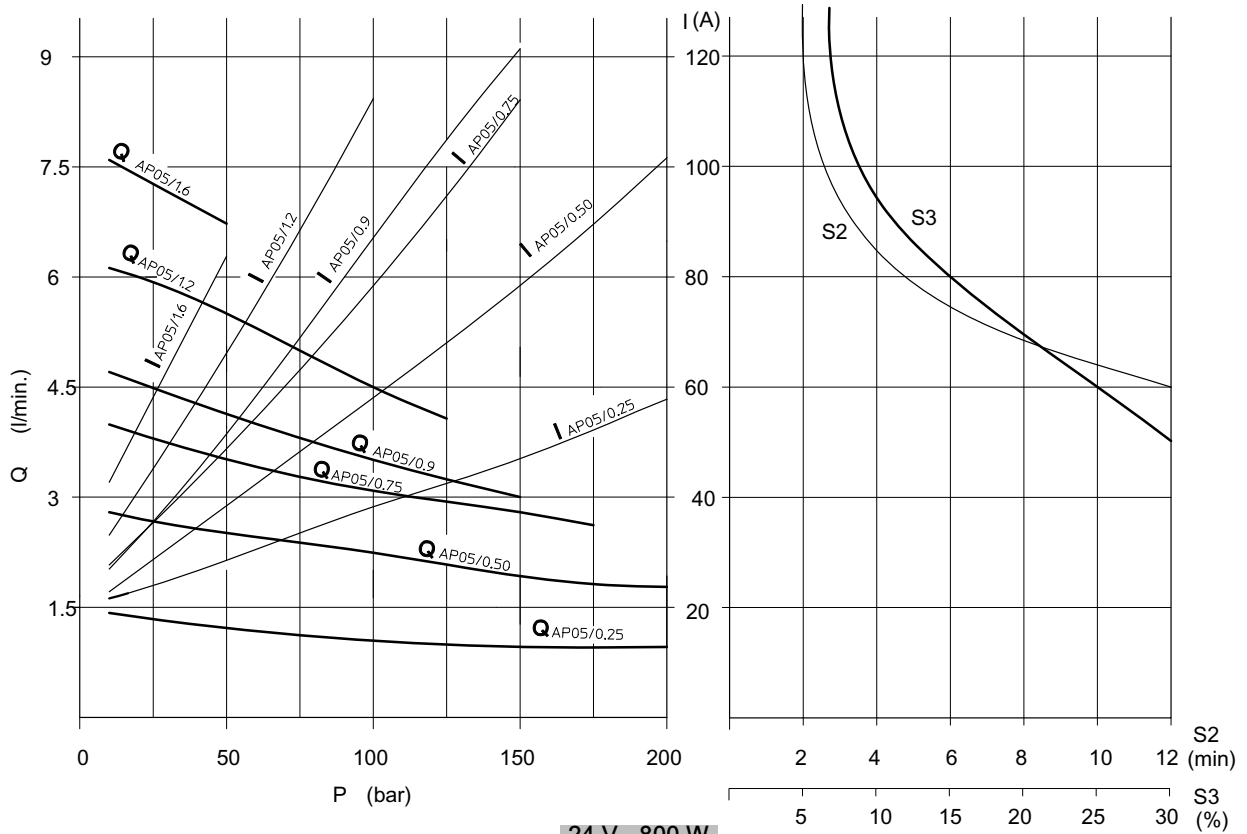

## 24 V - 800 W

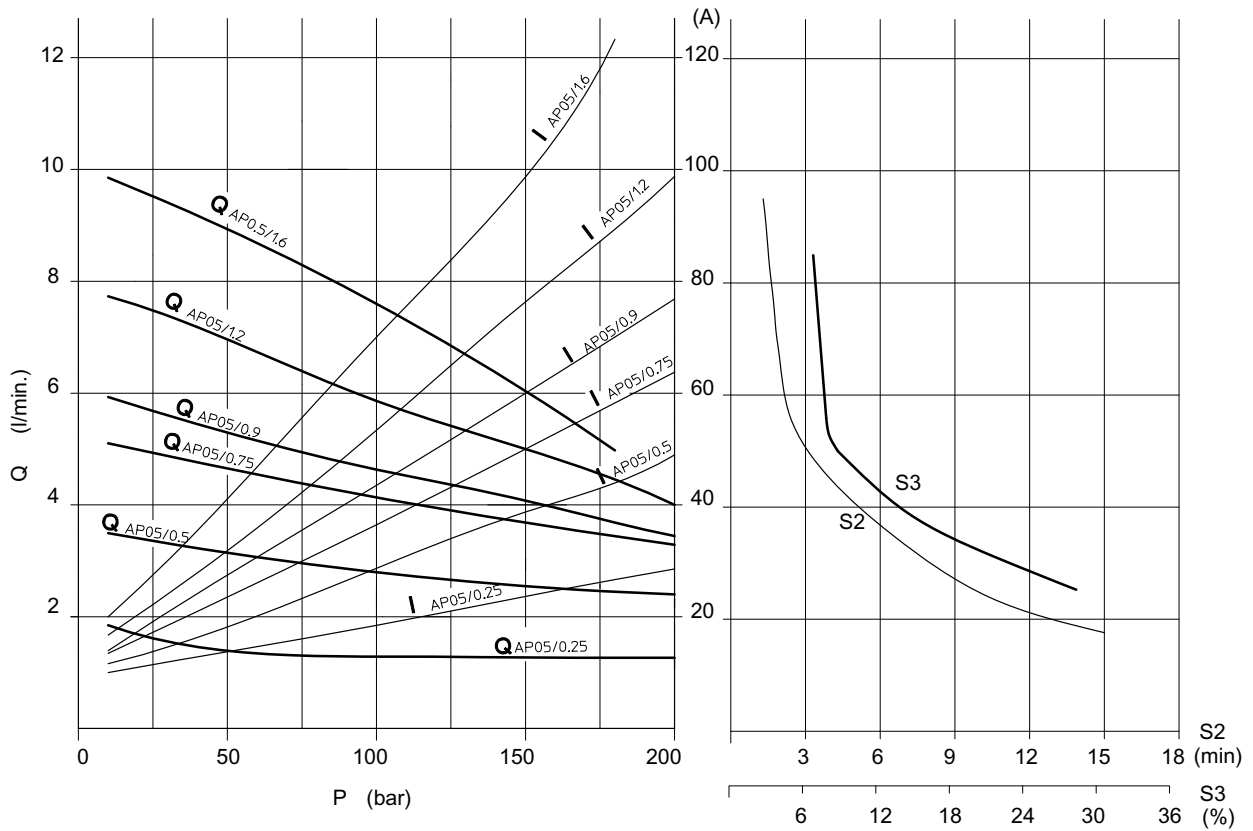



## 8 Group 05 gear pumps

AP05 Type	Displacement		Max. pressure						n min.		n max.	
	cm <sup>3</sup> /rev	Cu. In. P. R.	P1		P2		P3		P ≤ P1	P > P1	P ≤ P1	P > P1
			bar	P.S.I.	bar	P.S.I.	bar	P.S.I.				
AP05/0.25	0.25	.015	170	2400	180	2600	200	2900	800	1000	6000	7000
AP05/0.5	0.5	.030	190	2700	210	3000	230	3300	650	800	6000	7000
AP05/0.75	0.75	.045	190	2700	210	3000	230	3300	650	800	6000	7000
AP05/0.9	0.9	.055	190	2700	210	3000	230	3300	650	800	6000	7000
AP05/1.2	1.2	.073	170	2400	180	2600	200	2900	550	700	5000	6000
AP05/1.6	1.6	.097	170	2400	180	2600	200	2900	550	700	5000	6000

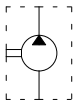

Group **AP05** Code **819**

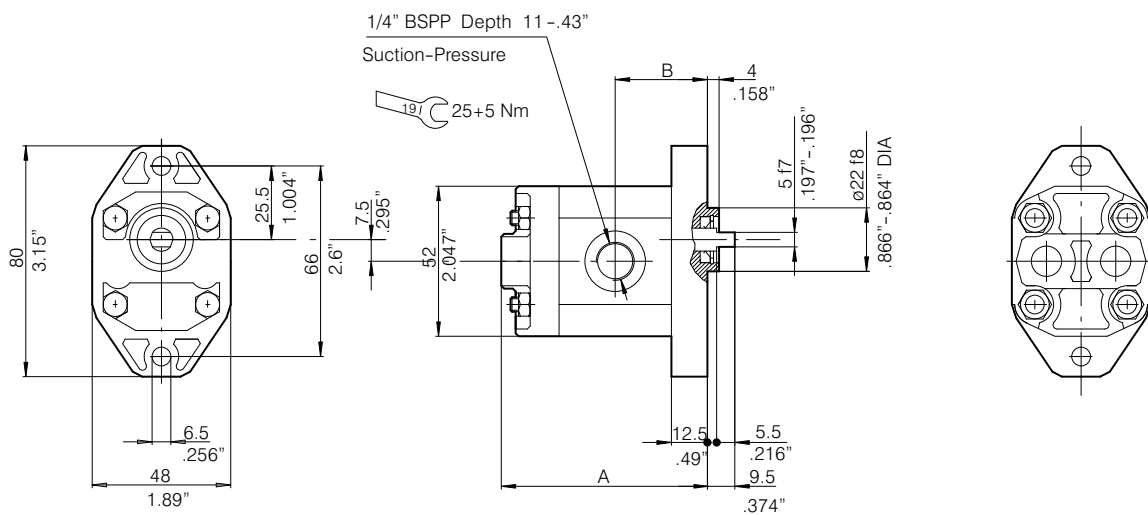

Type	Displacement cm <sup>3</sup> /rev	Dimensions				Order code Counterclockwise rotation: S
		A		B		
		mm	inches	mm	inches	
AP05/0.25	0.25	64.5	2.54	29	1.41	200100264304
AP05/0.5	0.5	67	2.64	30.5	1.2	200100364302
AP05/0.75	0.75	69	2.72	31.5	1.24	200100464302
AP05/0.9	0.9	70.5	2.77	32.3	1.26	200100564304
AP05/1.2	1.2	73	2.87	33.5	1.32	200100664302
AP05/1.6	1.6	77	3.03	35.5	1.40	200100864301

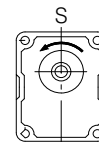

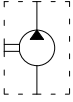

Group **AP05**



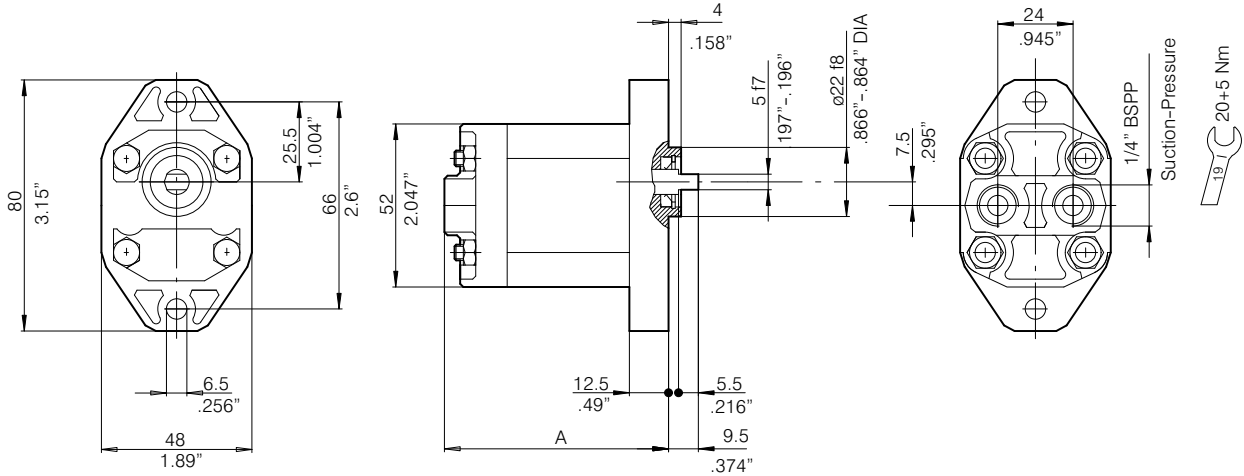

Code **319**

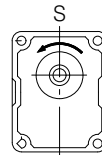

Type	Displacement cm <sup>3</sup> /rev	Dimensions		Order code Counterclockwise rotation: S
		A		
		mm	inches	
AP05/0.25	0.25	64.5	2.54	200100214301
AP05/0.5	0.5	67	2.64	200100314301
AP05/0.75	0.75	69	2.72	200100414301
AP05/0.9	0.9	70.5	2.77	200100514301
AP05/1.2	1.2	73	2.87	200100614301
AP05/1.6	1.6	77	3.03	200100814301

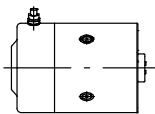
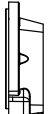
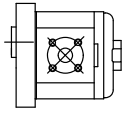

## 9 Electro-Motor-Pumps for group 1 pumps

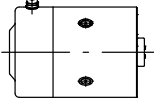
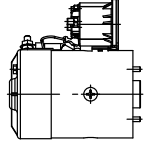
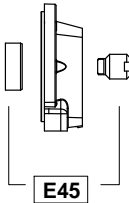
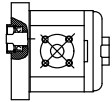
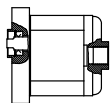
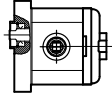
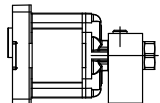
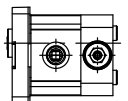
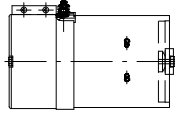
Motor	Drive/Flange	Pump
		
		
<div style="display: flex; justify-content: space-around;"> <div style="border: 1px solid black; padding: 5px; width: 45%;"> <p style="text-align: center;">Without starting relay</p>  <p>12V-1600W <span style="border: 1px solid black; padding: 2px;">C135AB/H0</span></p> <p>24V-2200W <span style="border: 1px solid black; padding: 2px;">C240AB/S0</span></p> <p>24V-2200W <span style="border: 1px solid black; padding: 2px;">C242AD/F0</span></p> </div> <div style="border: 1px solid black; padding: 5px; width: 45%;"> <p style="text-align: center;">With starting relay</p>  <p>C135AB/H0 + R109</p> <p>C240AB/S0 + R215</p> <p>C240AD/F0 + R215</p> </div> </div>	 <p style="text-align: center;"><b>E45</b></p>	 <p style="text-align: center;"><b>AP100 - 219</b></p>  <p style="text-align: center;"><b>AP100 - 319</b></p>  <p style="text-align: center;"><b>AP100 - 819</b></p>  <p style="text-align: center;"><b>AP100 - 319 with VMI</b></p>  <p style="text-align: center;"><b>AP100 - 819 with VMI</b></p>
 <p>24V-3000W <span style="border: 1px solid black; padding: 2px;">C248AK/Z0*</span></p>	<p style="text-align: center;">*</p> <p style="text-align: center;">please contact our Sales Centre</p>	

El. motor	E45
C135AB/H0	●
C135AB/H0+R109	●
C240AB/S0	●
C240AB/S0+R215	●
C242AD/F0	●
C240AD/F0+R215	●
C248AK/Z0*	* Please contact our Sales Centres

## 10 D.C. Electric motors for group 1 pumps

Voltage	12 V	24 V
Nominal Power	1600 W	2200 W

Protection index: ..... IP44 (12 V) - IP54 (24 V)  
 Insulation class: ..... F  
 Type of winding: ..... Compound  
 Brushes kit: ..... (12/1600) 200544138022  
 ..... (24/2200) 200544138023  
 Minimum brushes length: ..... 12.5 mm (0.5 inches)

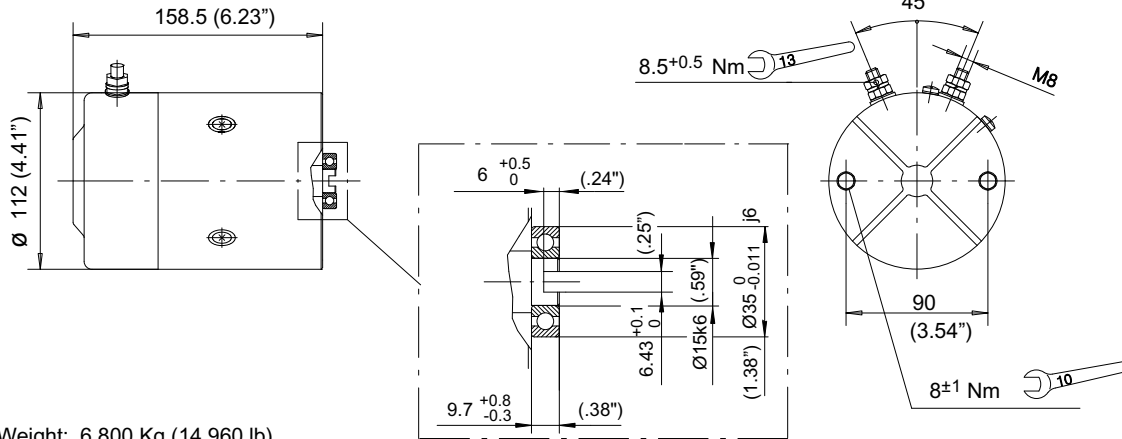

Weight: 6.800 Kg (14.960 lb)

	Motor		Motor with relay			
Rotation Right						
Type	C135AB/H0	C240AB/S0	C135AB/H0 +R109	C240AB/S0 +R215		
Code	200543913706	200543924007	200763310240	200763310330		
Relay			Standard			
Relay type			R109	R215		

### Motor mounting position

Standard positions

Relay standard positions

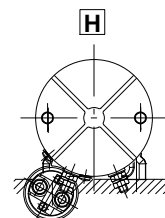
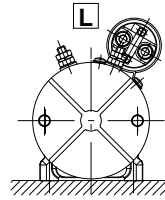
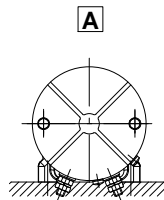
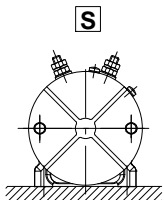

## 12 V - 1600 W

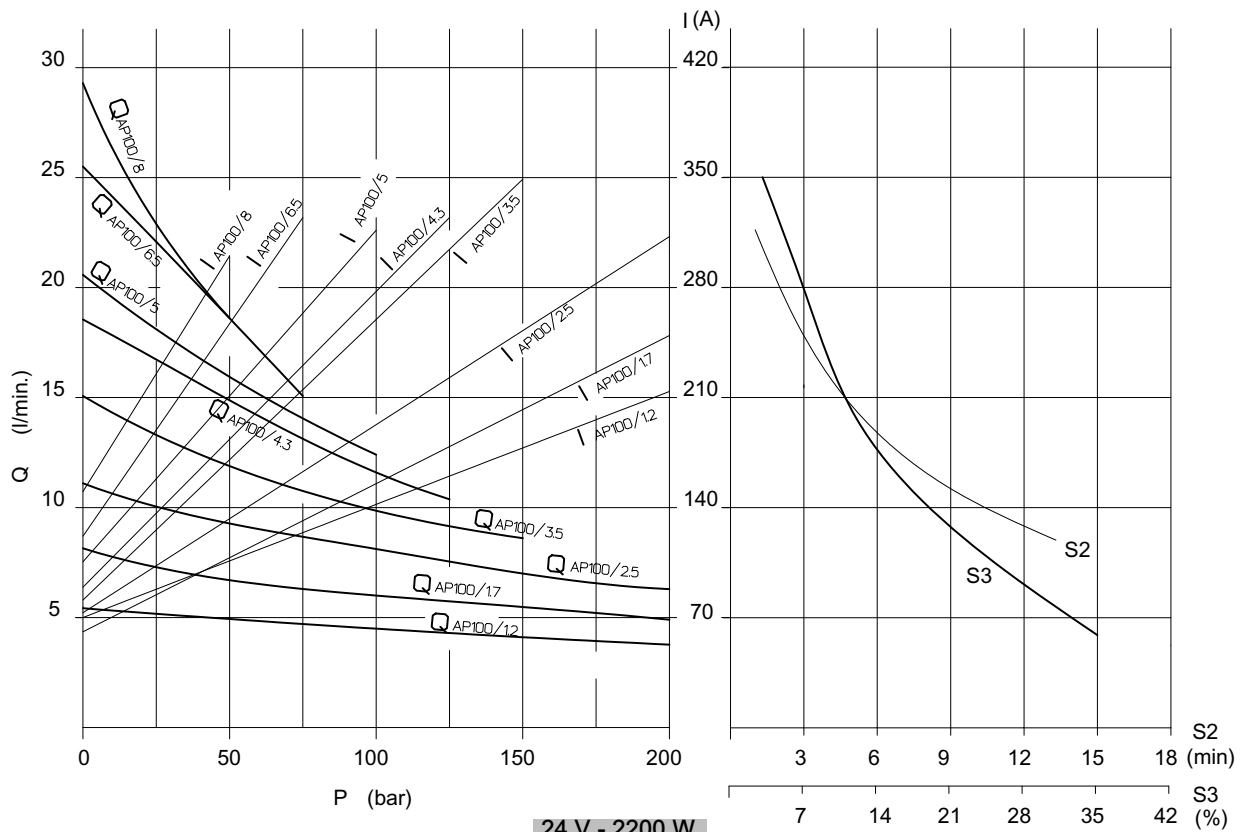

## 24 V - 2200 W

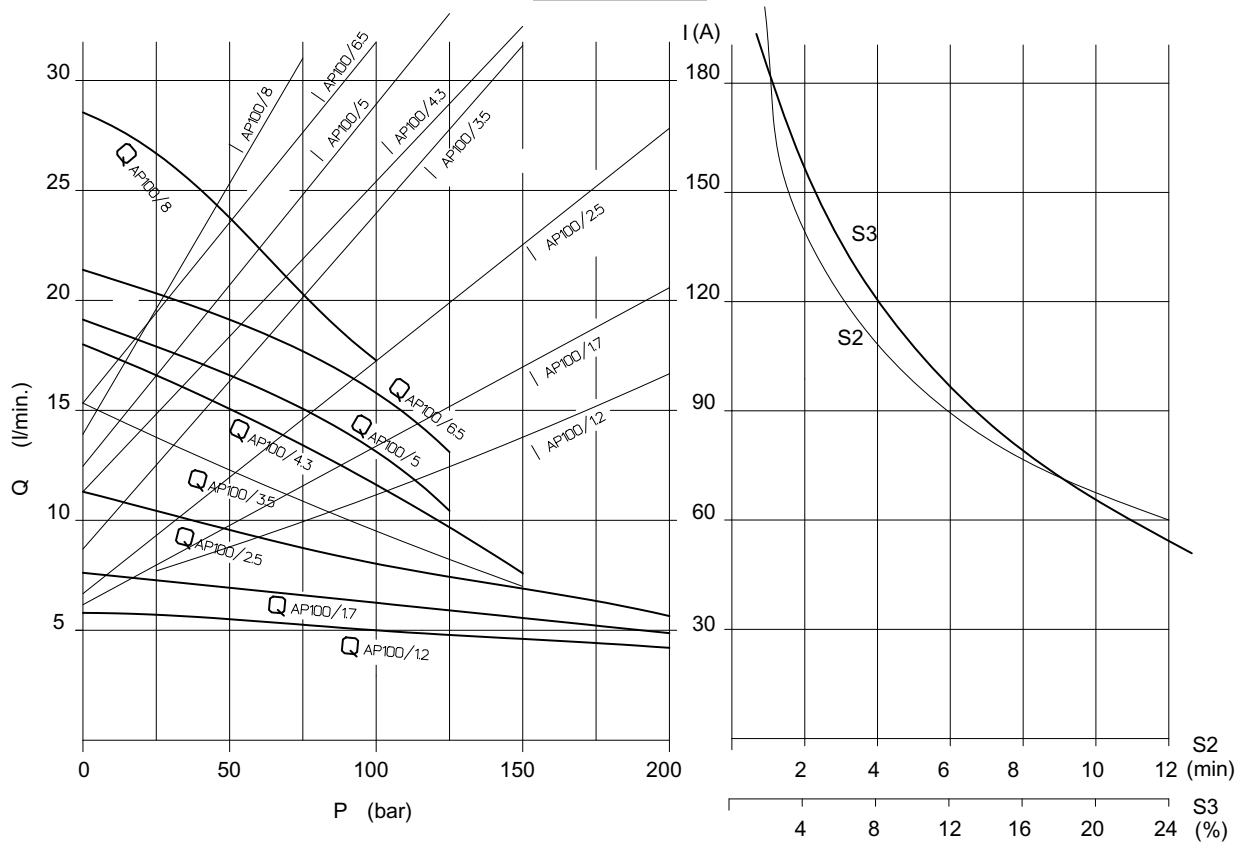

Voltage	Nominal Power
24 V	2500 W

Protection index: ..... IP54  
 Insulation class: ..... B  
 Type of winding: ..... SERIE  
 Brushes kit: ..... 200544138034  
 Minimum Brushes length: ..... 5 mm (0.2 inches)

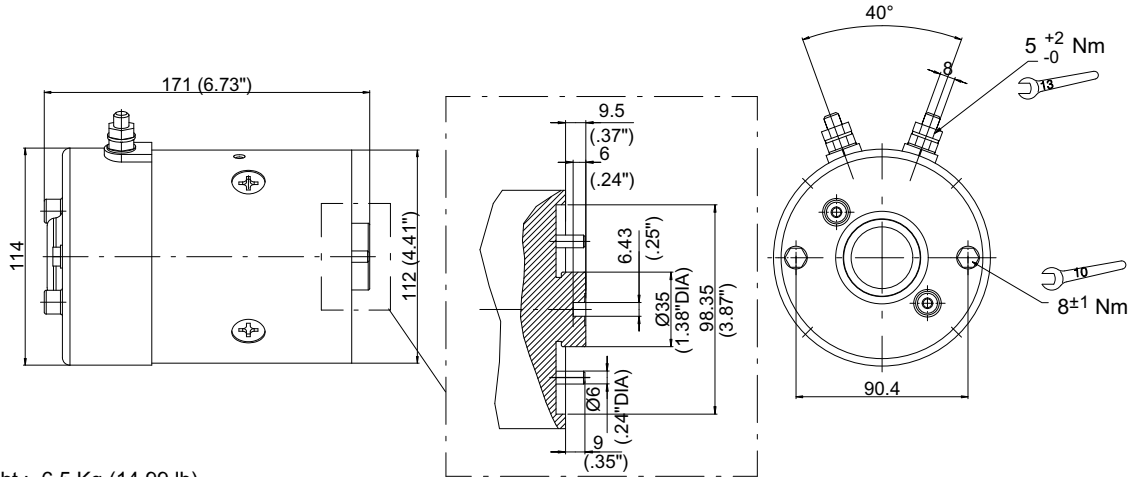

Weight : 6.5 Kg (14.99 lb)

	Motor		Motor with relay	
Rotation Right				
Type	C242AD/F0		C242AD/F0 +R215	
Code	200543924211		200763320340	
Relay			Standard	
Relay type			R109	R215

Motor mounting positions

Standard positions

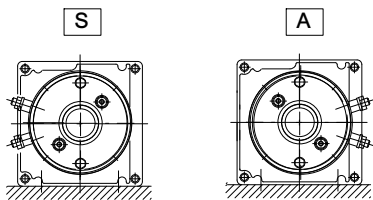

Standard positions



Relay mounting positions

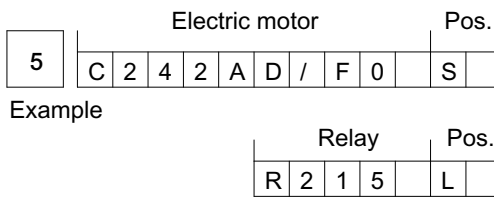
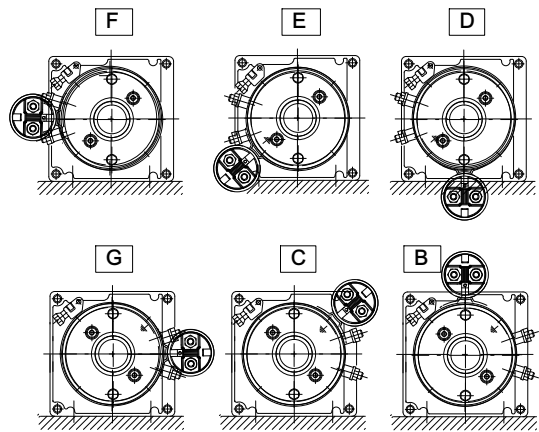

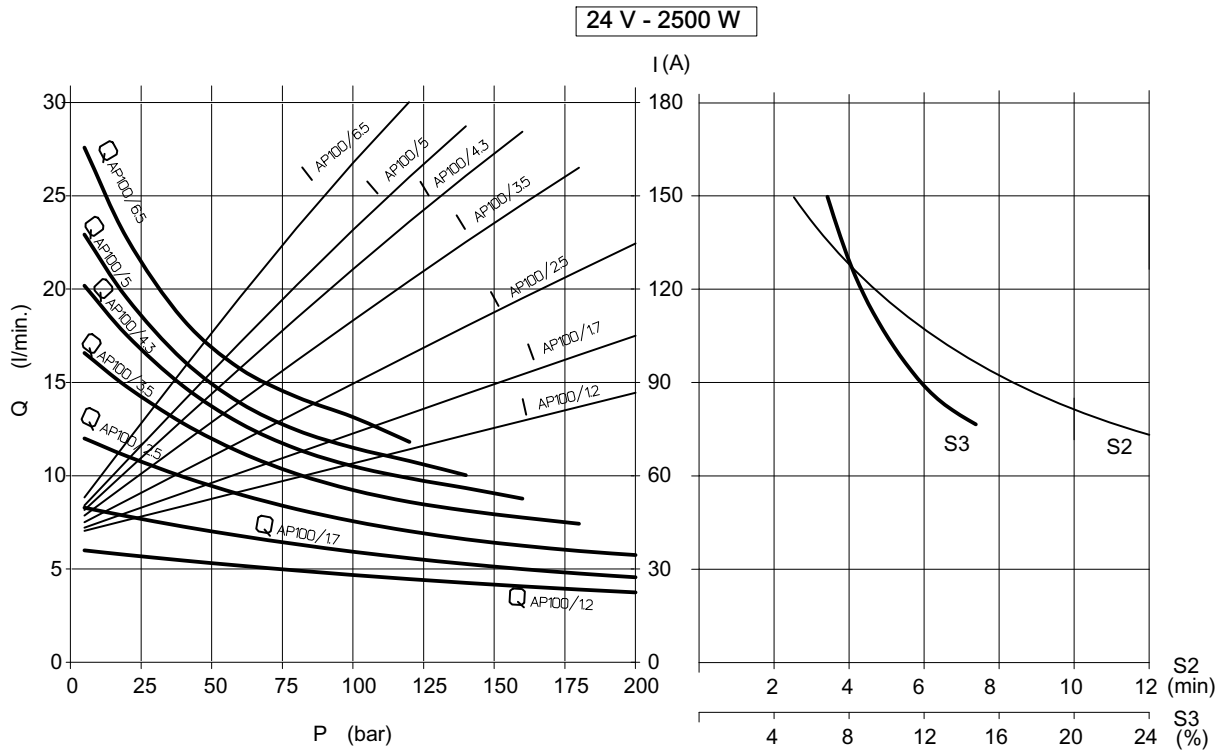

Voltage	Nominal Power
24 V	3000 W

Protection index: ..... IP43  
 Insulation class: ..... F  
 Type of winding: ..... Compound  
 Brushes kit: ..... 200544138029  
 Minimum brushes length: ..... 15 mm (0.6 inches)

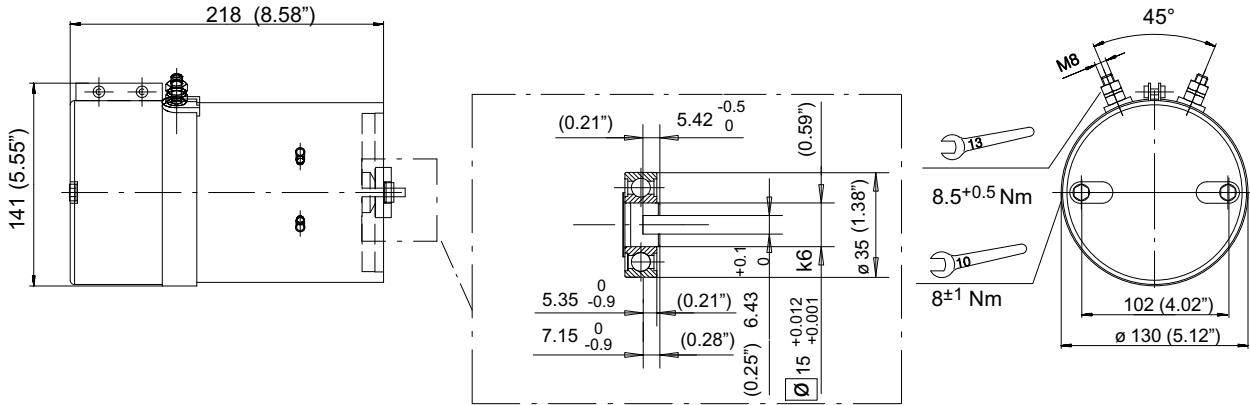

Weight : 12 Kg (26.4 lb)

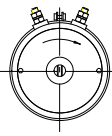
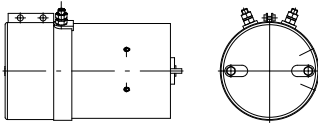
	Motor	Motor with relay	
 Rotation Right			
Type	24 V - 3000 W		
Code	C248AK/Z0		
Relay	200543924601		
Relay type			

### Motor mounting position

Standard positions

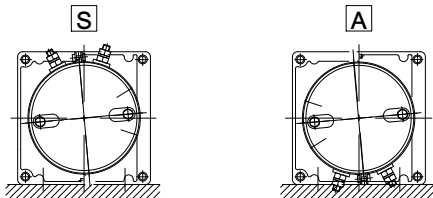

24 V - 3000 W

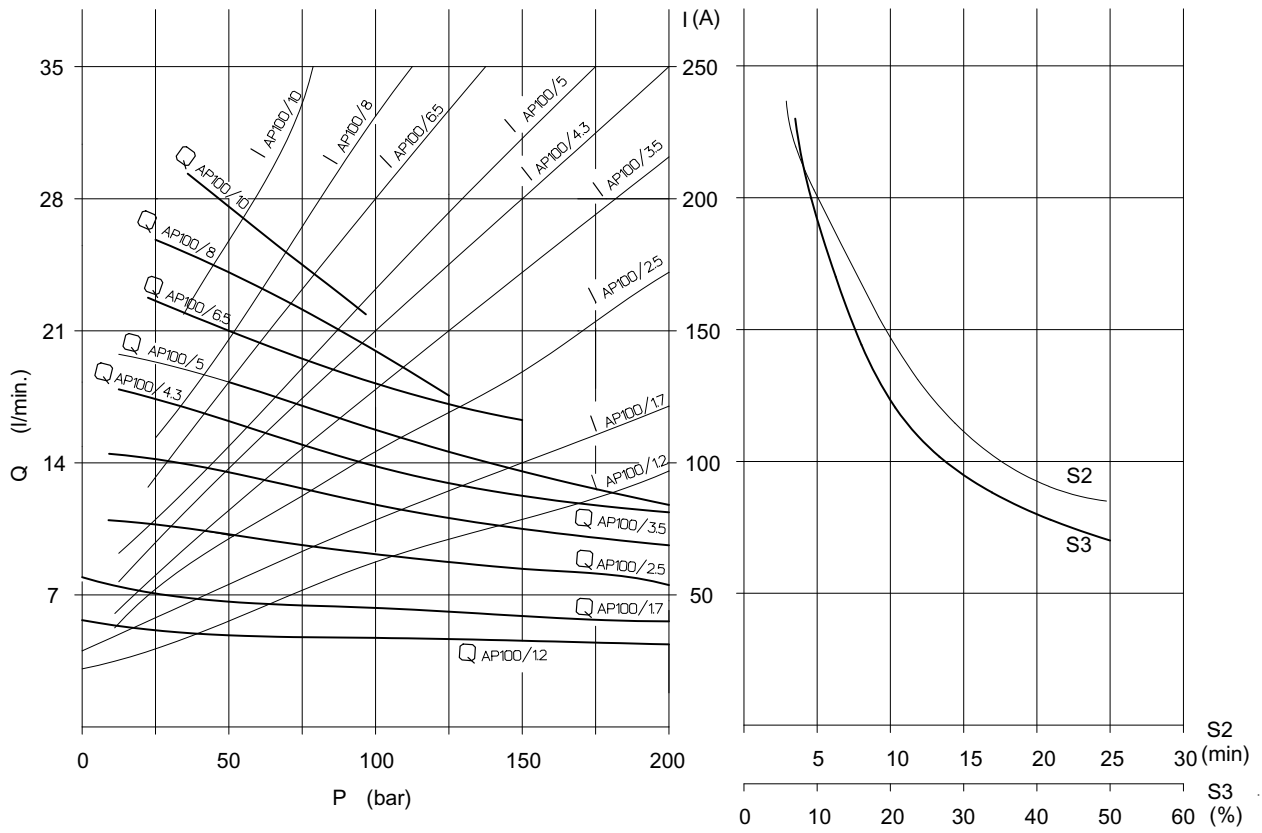

## 11 Drives and connecting flange for group 1 pumps

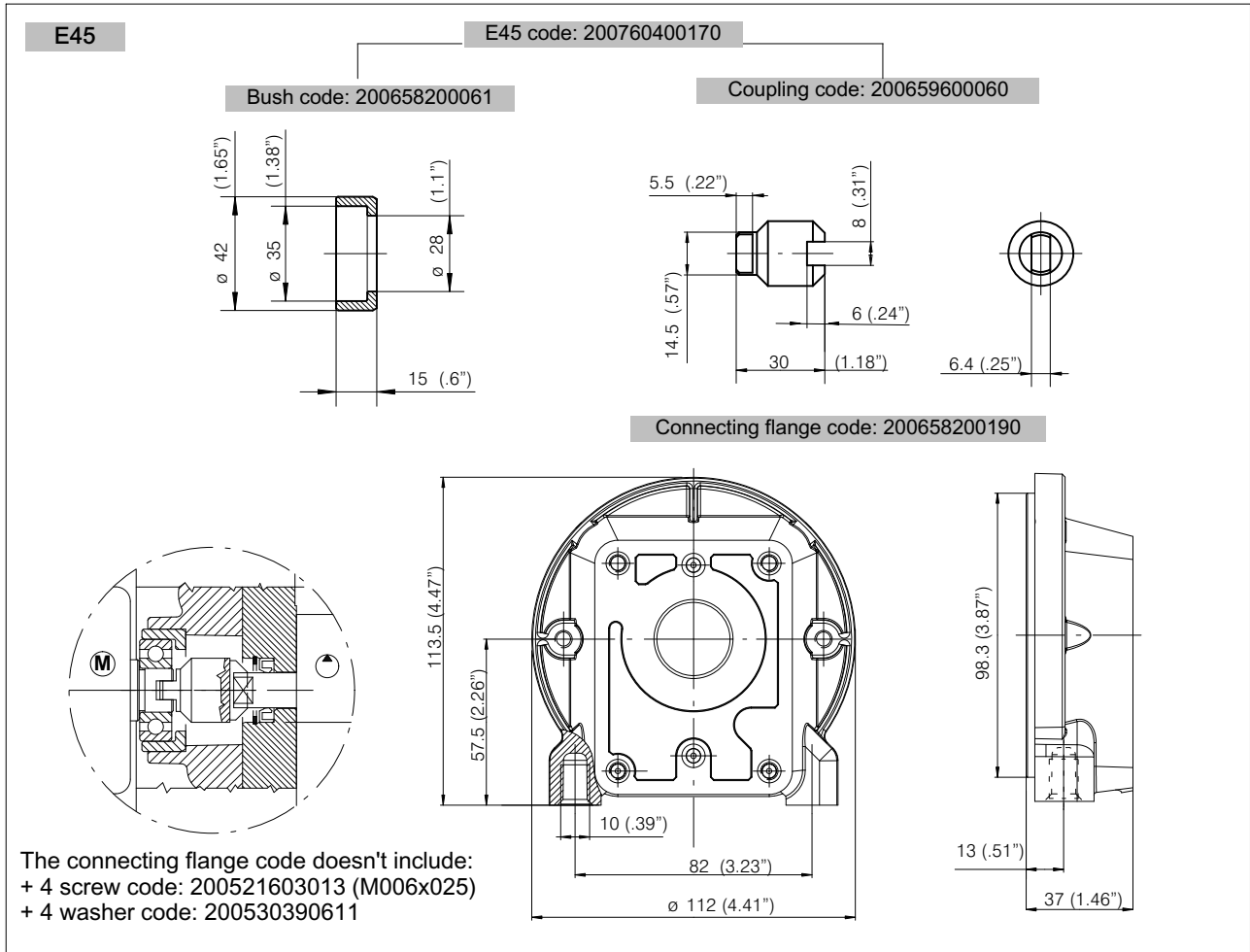

## 12 Group 1 gear pumps

AP100 Type	Displacement		Max. pressure						n min.		n max.	
	cm <sup>3</sup> /rev	Cu. In. P. R.	P1		P2		P3		P ≤ P1	P > P1	P ≤ P1	P > P1
			bar	P.S.I.	bar	P.S.I.	bar	P.S.I.				
AP100/1.2	1.2	.073	210	3000	250	3600	280	4000	800	1000	4500	5000
AP100/1.7	1.7	.103	210	3000	250	3600	280	4000	650	800	4500	5000
AP100/2.5	2.5	.152	210	3000	250	3600	280	4000	650	800	4500	5000
AP100/3.5	3.5	.213	210	3000	230	3300	250	3600	650	800	3500	4000
AP100/4.3	4.3	.262	210	3000	230	3300	250	3600	550	700	3500	4000
AP100/5	5.0	.305	210	3000	230	3300	250	3600	500	650	3000	3500
AP100/6.5	6.5	.396	190	2700	220	3150	240	3400	500	650	2500	3000
AP100/8	7.8	.476	180	2600	210	3000	230	3300	500	650	2500	3000
AP100/10	10.0	.610	150	2150	180	2600	200	2900	500	650	2000	2500

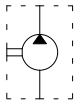

Group **AP100** Code **219**

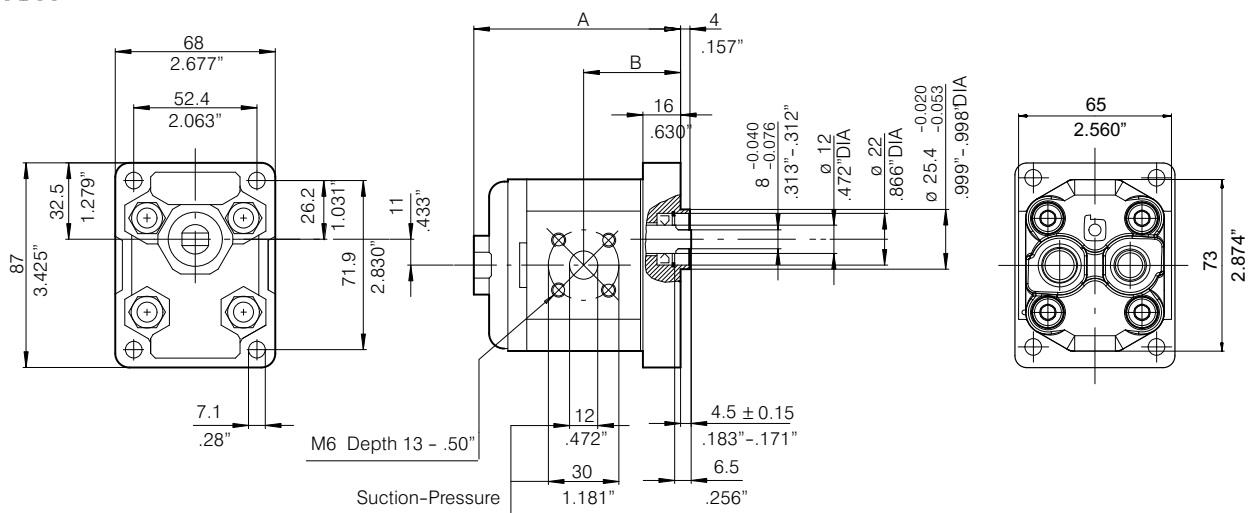

Type	Displacement cm <sup>3</sup> /rev	Dimensions				Order code Counterclockwise rotation: S
		A		B		
		mm	inches	mm	inches	
AP100/1.2	1.2	82.5	3.25	38.5	1.51	200101114306
AP100/1.7	1.7	84.5	3.33	39.5	1.55	200101214307
AP100/2.5	2.5	88	3.46	41	1.61	200101314306
AP100/3.5	3.5	92	3.62	43.5	1.71	200101414306
AP100/4.3	4.3	96	3.78	45	1.77	200101514306
AP100/5	5	98.5	3.88	46.5	1.83	200101614304
AP100/6.5	6.5	103.5	4.07	49	1.93	200101714304
AP100/8	7.8	109	4.29	52	2.05	200101814302
AP100/10	10	118	4.64	56.5	2.22	

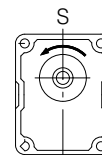

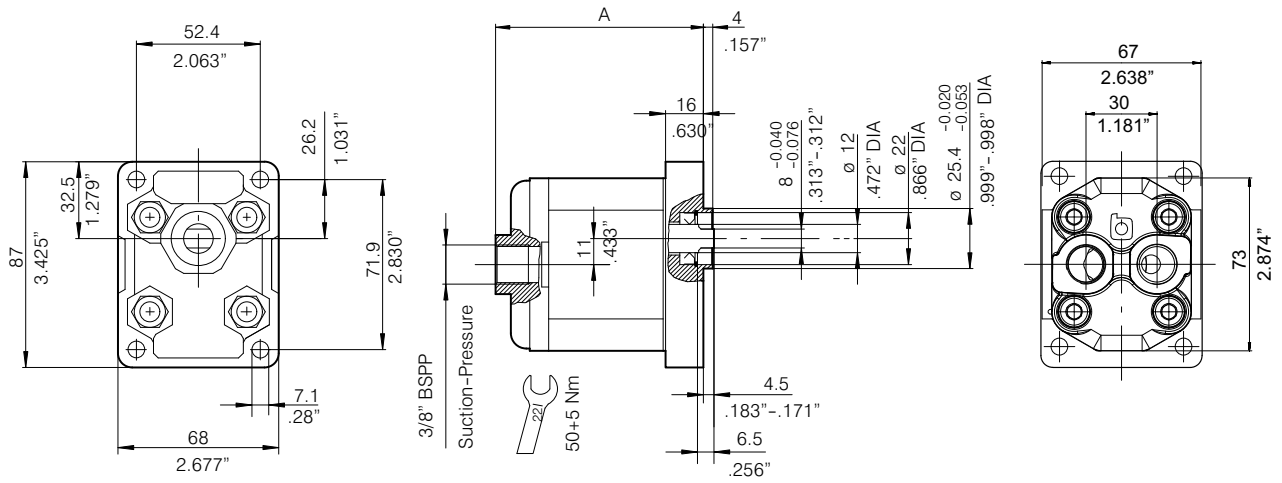
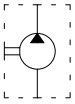

Type	Displacement cm <sup>3</sup> /rev	Dimensions		Order code Counterclockwise rotation: S
		mm	inches	
AP100/1.2	1.2	82.5	3.25	200101114307
AP100/1.7	1.7	84.5	3.33	200101214308
AP100/2.5	2.5	88	3.46	200101314307
AP100/3.5	3.5	92	3.62	200101414307
AP100/4.3	4.3	96	3.78	200101514308
AP100/5	5	98.5	3.88	200101614305
AP100/6.5	6.5	103.5	4.07	200101714305
AP100/8	7.8	109	4.29	200101814303
AP100/10	10	118	4.64	

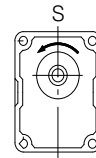

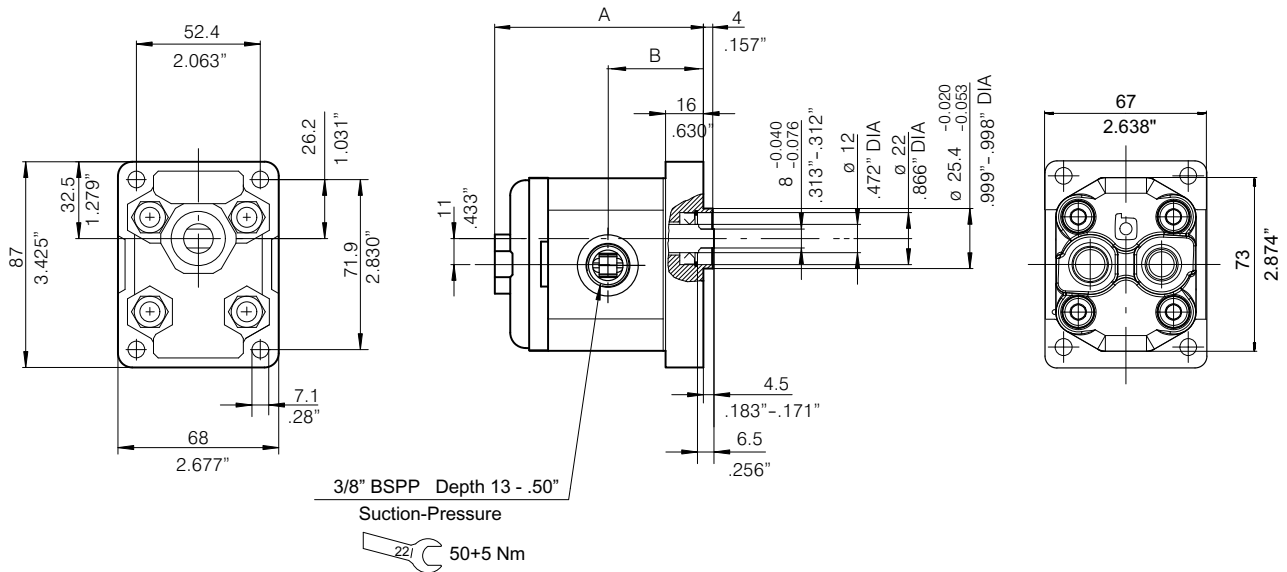
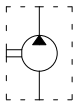

Type	Displacement cm <sup>3</sup> /rev	Dimensions A		Dimensions B		Order code Counterclockwise rotation: S
		mm	inches	mm	inches	
AP100/1.2	1.2	82.5	3.25	38.5	1.51	
AP100/1.7	1.7	84.5	3.33	39.5	1.55	
AP100/2.5	2.5	88	3.46	41	1.61	200101314308
AP100/3.5	3.5	92	3.62	43.5	1.71	200101414308
AP100/4.3	4.3	96	3.78	45	1.77	
AP100/5	5	98.5	3.88	46.5	1.83	
AP100/6.5	6.5	103.5	4.07	49	1.93	
AP100/8	7.8	109	4.29	52	2.05	
AP100/10	10	118	4.64	56.5	2.22	

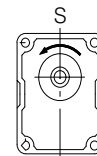

## 12.1 Special block with relief valve integrated

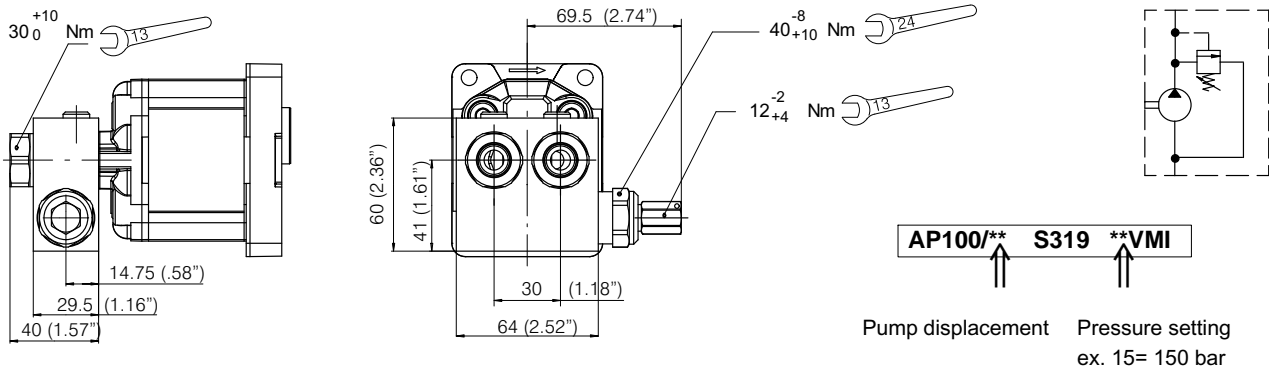

Block code (including valve and fittings)	Setting range
200987400450	30 - 95 bar
200987400910	95 - 210 bar

## 12.2 Back cover with relief valve integrated

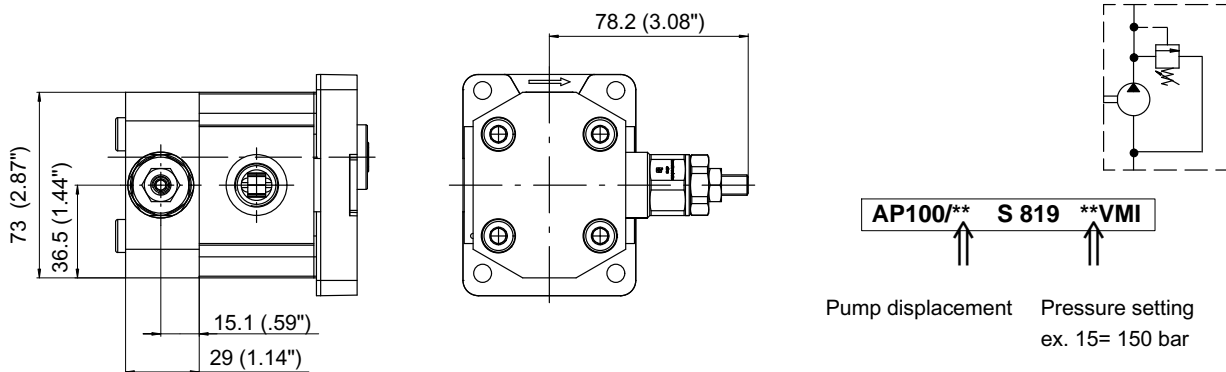

Complete pump code	Setting valve range
200101214312	96 - 220 bar
200101214311	221 - 350 bar

For relief valve setting and tightening torque values, see section 12.2.1

## 12.2.1 Pressure relief valve : \*\*VM01C

Direct acting  
Balanced piston  
Adjustable setting  
Four setting ranges

Max. pressure. .... 350 bar \*\*\*  
Max. flow rate ..... 60 l/min.  
Temperature range ..... -20/+100 °C  
Weight ..... 0.155 Kg.

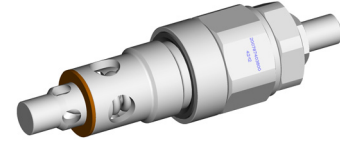
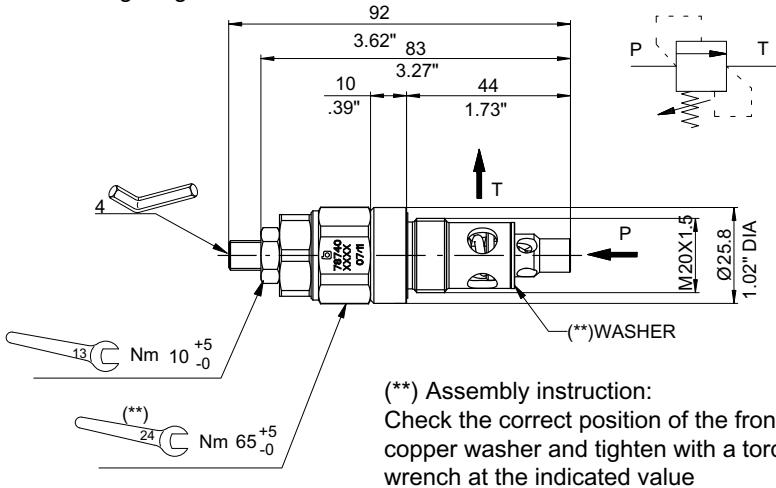

The valve can be sealed against tampering

Option: plastic tamper proof cap CAP01  
code 200678400562

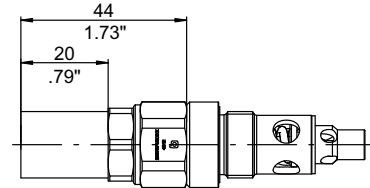

Pressure viscosity characteristic 46 cSt at 40°C

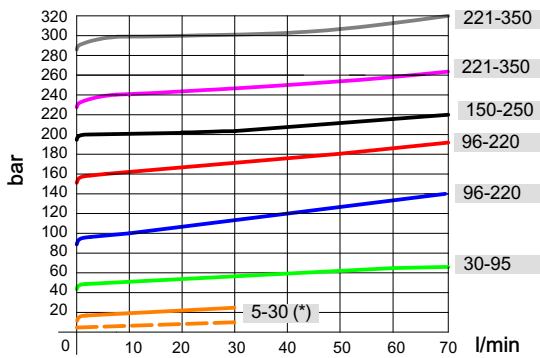

(\*) see performances trace/minimum pressure setting (---)

The purpose of a relief valve is to keep the maximum system pressure at a safe level. When the hydraulic power unit is supplied with pressure relief valves, the correct calibration is provided by Bucher Hydraulics S.p.A. and there are no reasons to change this value.

\*\*\* Maximum admitted pressure value: 230 bar when used into power pack bodies.

### Pressure setting

For present values other than those indicated, replace the first two digits of the designation with the setting required. For example, required setting 120 bar: designation type 12 VM01C. Always check that the required value falls within the standard ranges of adjustment.

Performances	
Max. flow	60 l/min.
Pressure setting flow	5 l/min
Max internal leakage	200 cm <sup>3</sup> /min at 80% of nominal pressure setting
Oil viscosity	12 to 400 cSt
Oil temperature	-20 to 100 °C
Recommended filtration	21/19/16 (10 NAS 1638)
Marking info:	Printed code and date

Spring	Setting range	Standard setting	Q max (l/min)	Type	Code
00	Plugged	Without valve	-	00VC00	200978400140
02	5 - 30 bar	20 bar	30 (*)	02VM01C	200787403600
05	30 - 95 bar	50 bar	60	05VM01C	200787403480
12	96 - 220 bar	120 bar	60	12VM01C	200787403420
15	150 - 250 bar	150 bar	60	15VM01C	200787403470
23	221 - 350 bar	230 bar	60	23VM01C	200787403430

## 13 Group 2 gear pumps

Since Bucher produces a wide range of hydraulic external gear pumps we can offer also customized motor-pumps in larger size, for example with gear pumps of the group 2 (series AP212).

Below are represented just a few examples of motor-pumps combined with fan cooled and not fan cooled electric motors, both in DC and AC current.

The motor-pumps may also integrate different hydraulic circuits like pressure relief valve, flow control valve, etc, in order to simplify the customer circuit.

\* Further information regarding AP212 pumps: see catalogue 200-P-991230-E. Please contact our Sales Centres for other information.

Available on demand only. Minimum batch quantity may be required

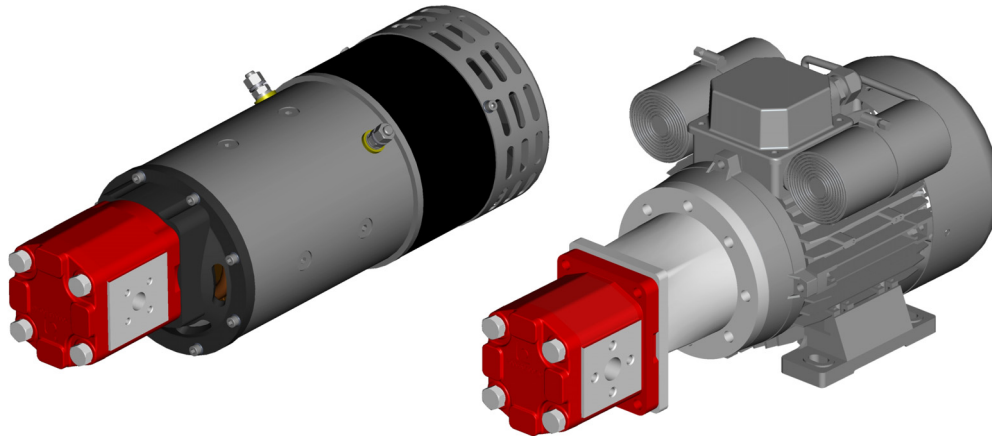

AP212 with standard back cover

AP212 with relief valve VM series

AP212 with flow regulator Q1 or QE series

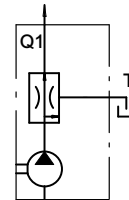
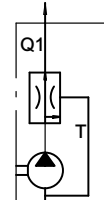
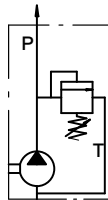
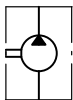
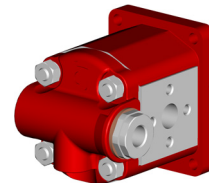
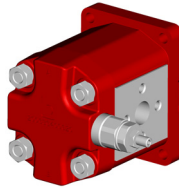
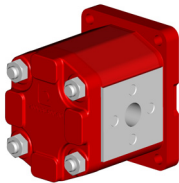

Type	AP/APR212 Displacement		AP/APR212LN Displacement		Max. pressure						n min. P2 < 100 bar rpm	n min. 100 < n < 180 bar rpm	n min. 180 < n < P2 rpm	n max. rpm
	cm <sup>3</sup> /rev	Cu.In. P.R.	cm <sup>3</sup> /rev	Cu.In. P.R.	P1 (continuous)		P2 (intermittent)		P3 (peak)					
					bar	P.S.I.	bar	P.S.I.	bar	P.S.I.				
4.5	4.4	.269	4.5	.275	250	3600	280	4000	300	4300	600	1200	1400	4000
6.5	6.4	.391	6.6	.403	250	3600	280	4000	300	4300	600	1200	1400	4000
8.5	8.4	.513	8.7	.531	250	3600	280	4000	300	4300	600	1000	1400	4000
11	11.1	.677	11.5	.702	250	3600	280	4000	300	4300	500	900	1200	3500
15	15.1	.921	15.7	.958	250	3600	280	4000	300	4300	500	750	1000	3500
19	19.2	1.172	19.8	1.208	210	3000	240	3500	260	3700	500	750	1000	3000
22	22.2	1.355	23	1.404	180	2600	210	3000	230	3300	500	750	900	3000
26	26.2	1.599	27.1	1.654	170	2500	200	2850	220	3150	500	750	1000	2800
22**	22.2	1.355	23	1.404	220	3150	240	3450	260	3700	500	750	900	3000
26**	26.2	1.599	27.1	1.654	200	2850	230	3300	250	3600	500	750	1000	2800

\*\* obtained with a specific balancing plate, please contact our Sales Centres

14 Components

14.1 Steel bracket SL01

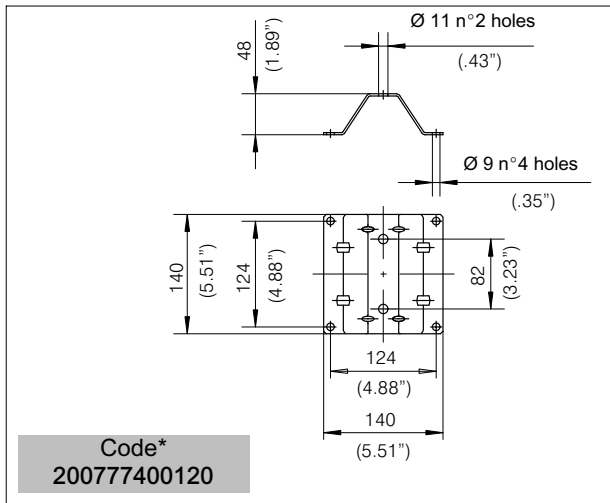

14.2 Protective plastic cover for D.C. motors PP01

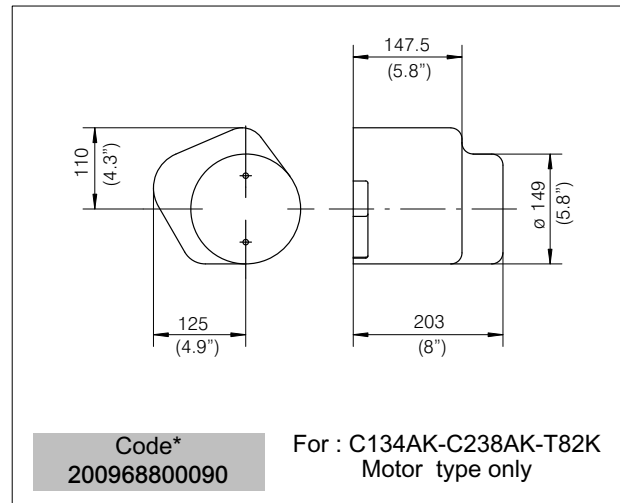

\* Supplied with screws, washers and nuts too

## 15 Order designation examples of Electro-Motor-Pumps

### Group 05 E. motor without relay

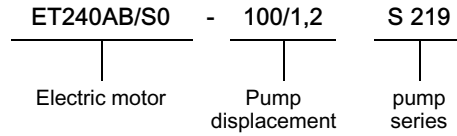
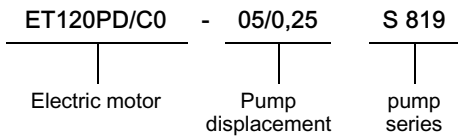

### Group 05 E. motor with relay

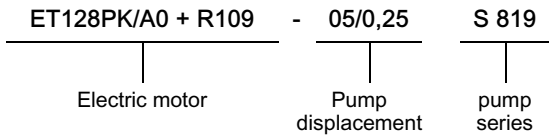

### Group 1 E. motor with relay and VMI

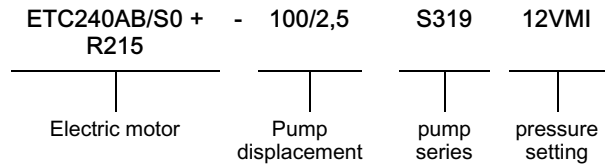

### Group 1 E. motor without relay

### Product identification plate

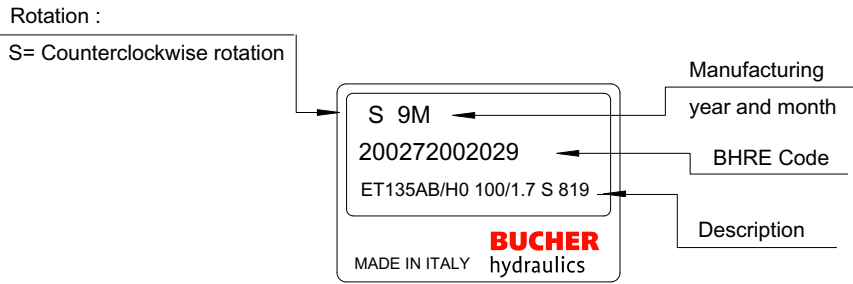

Manufacturing month	Manufacturing year						
	2017	2018	2019	2020	2021	2022	2023
January	7A	8M	9M	0M	1M	2M	3M
February	7B	8N	9N	0N	1N	2N	3N
March	7C	8P	9P	0P	1P	2P	3P
April	7D	8Q	9Q	0Q	1Q	2Q	3Q
May	7E	8R	9R	0R	1R	2R	3R
June	7F	8S	9S	0S	1S	2S	3S
July	7G	8T	9T	0T	1T	2T	3T
August	7H	8U	9U	0U	1U	2U	3U
September	7I	8V	9V	0V	1V	2V	3V
October	7J	8Z	9Z	0Z	1Z	2Z	3Z
November	7K	8X	9X	0X	1X	2X	3X
December	7L	8Y	9Y	0Y	1Y	2Y	3Y



[info.it@bucherhydraulics.com](mailto:info.it@bucherhydraulics.com)

[www.bucherhydraulics.com](http://www.bucherhydraulics.com)

© 2018 by Bucher Hydraulics S.p.A., I-42124 Reggio Emilia

All rights reserved.

Data is provided for the purpose of product description only, and must not be considered as warranted characteristics in the legal sense. The information does not relieve users from the duty of conducting their own evaluations and tests. Because the products are subject to continual improvement, we reserve the right to amend the product specifications contained in this catalogue.

Classification: 440.405.000