

# CB1A 齿轮泵

## GROUP1 GEAR PUMPS

### 简介 General Description

CB1A 齿轮泵系高压小排量齿轮油泵，由一对高强度齿轮、轴套、泵体、前盖、后盖等主要部件组成，轴向间隙由高精度浮动轴套自动补偿，使得CB1A 齿轮泵具有高的机械效率和容积效率，该泵噪音低、可靠性高，广泛应用于卡车的液压系统，举升和传送机械，矿山机械，农业机械等。

The CB1A gear pump consists of a gear pair supported by two aluminum bearing blocks, a housing, front cover and rear cover. The axial clearance can be automatically compensated by the bearing blocks. The features of CB1A pump are simple structure, high mechanical and volumetric efficiency, low noise level as well as high reliability. It is widely used in the hydraulic system of truck, lift and deliver machinery, mine machinery, and agriculture machinery, etc.



### 型谱 Order Code

#### CB1A - F \* \* \* \*

20MPa	额定压力 Rated Pressure					空白 Omit	9 齿花键 9T Spline
1.3 - 13 mL/r	公称排量 Displacement					A	平键 Flat key
空白或 S Omit or S	SAE 油口 SAE O-ring boss	油口形式 Port Configurations				B	扁势 Tang
A	管螺纹 (BSPP) Gas Threaded Ports (BSPP)		空白 Omit	右旋 CW			
B	公制螺纹 Metric Threaded Ports		F	左旋 CCW			

### 外形尺寸图 Outline Dimension

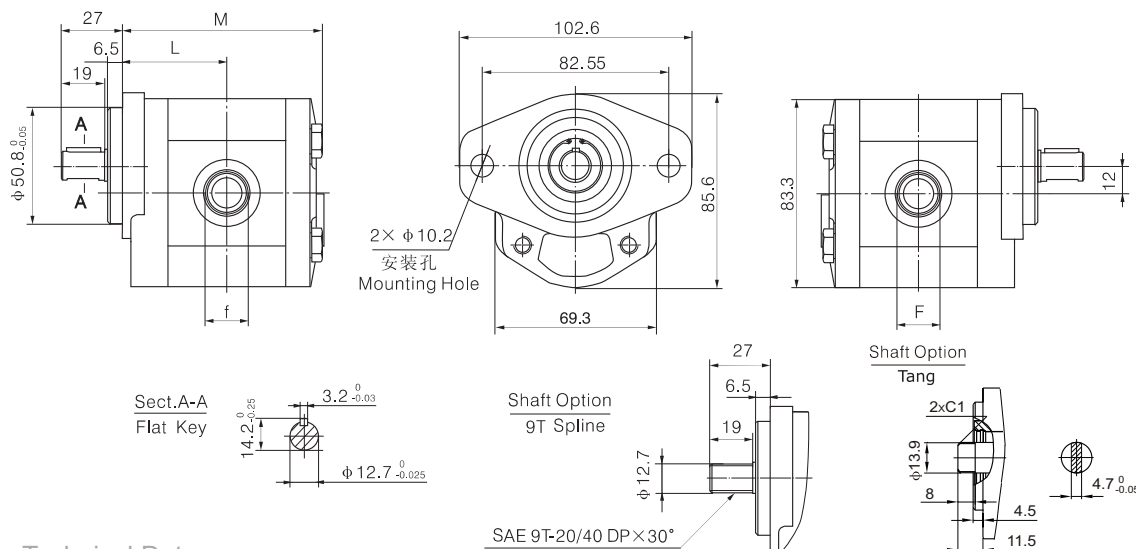

### 技术参数 Technical Data

Model 型号	Displacement 排量 mL/r (in <sup>3</sup> /r)	压力(MPa) pressure			转速(RPM)pressure		尺寸 Dimension			
		P1	P2	P3	Rated	Max	L(mm)	M(mm)	F 进油口(Inlet)	f 出口口(Outlet)
CB1A-F1.3*	1.36 (0.0830)	20	25	28	2000	4000	42	80.3	SAE 口 SAE port 3/4-16UN	SAE 口 SAE port 9/16-18UN
CB1A-F2 *	2.05 (0.1251)						43	82.3		
CB1A-F2.7*	2.74 (0.1672)						44	84.3		
CB1A-F3.2 *	3.42 (0.2087)						45	86.3		
CB1A-F4 *	4.10 (0.2502)						46	88.3		
CB1A-F5 *	5.13 (0.3131)						47.5	91.3		
CB1A-F6 *	6.16 (0.3759)						49	94.3		
CB1A-F7.5 *	7.52 (0.4589)	18	20	22	2000	3500	51	98.3	7/8-14UN G3/4"	3/4-16UN G1/2"
CB1A-F9 *	9.23 (0.5633)						3000	53.5		
CB1A-F10 *	10.95 (0.6682)	15	18	20	2000	2500	56	108.3	M22X1.5	M18X1.5
CB1A-F13 *	13.68 (0.8348)						2000	60		