



OIL SOLUTIONS

**BUCHER**  
hydraulics

PO Box 38  
Strathfieldsaye, VIC, 3551  
1800 OIL SOL  
1800 645 765

[sales@oilsolutions.com.au](mailto:sales@oilsolutions.com.au)

[www.oilsolutions.com.au](http://www.oilsolutions.com.au)

"For All Your Hydraulic Needs"

## Internal Gear Pumps

Series QX

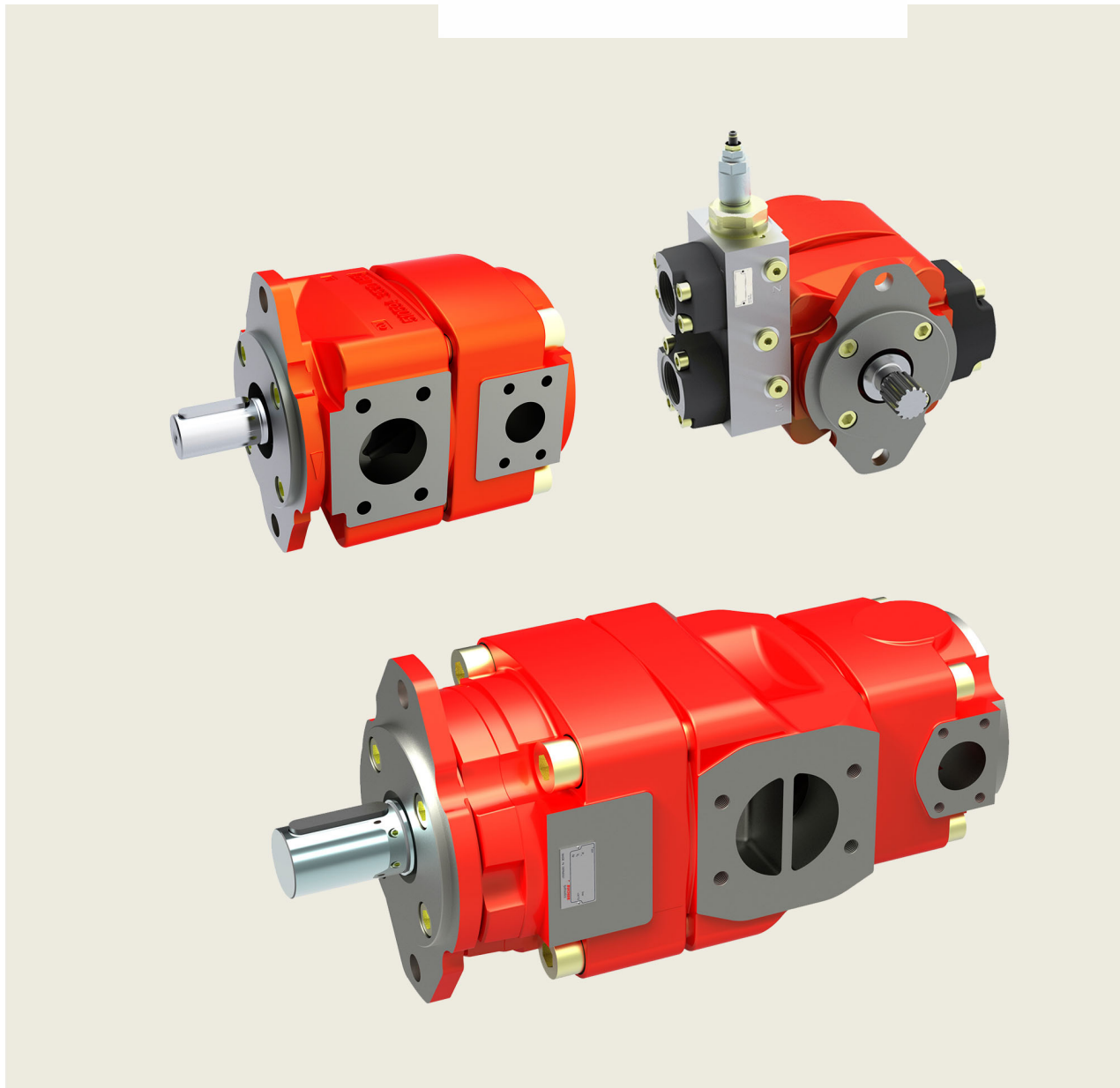

Reference: 100-P-00021-US-23



Contents	Page
<b>1</b>	<b>General</b> ..... <b>5</b>
1.1	Product description ..... 5
1.2	Advantages ..... 5
1.3	ATEX compliant explosion protection ..... 5
<b>2</b>	<b>Technical data</b> ..... <b>5</b>
2.1	General (deviating values according manufacturer's specification) ..... 5
2.2	Main characteristics for pressure range 1 ..... 6
2.3	Main characteristics for pressure range 2 ..... 7
2.4	Main characteristics for pressure range 3 ..... 7
2.5	Main characteristics for pressure range 4 ..... 8
<b>3</b>	<b>Performance graphs</b> ..... <b>9</b>
3.1	Noise level (Lp) ..... 9
3.2	Efficiency ( $\eta$ ) ..... 9
3.3	Operation with variable-speed drives ..... 11
<b>4</b>	<b>Single pumps</b> ..... <b>12</b>
4.1	Dimensions [inch] frame size 2 - 4 ..... 12
4.2	Dimensions [inch] frame size 5 - 8 ..... 13
4.3	Pressure range 1 ..... 14
4.4	Pressure range 2 ..... 14
4.5	Pressure range 3 ..... 15
4.6	Pressure range 4 ..... 15
4.7	Pressure range 4 with low-flow capability ..... 16
4.8	Ordering code for single pumps ..... 17
<b>5</b>	<b>Double pumps</b> ..... <b>18</b>
5.1	Selection table ..... 18
5.2	Dimensions [inch] ..... 19
5.3	Ordering code for double pumps ..... 28
<b>6</b>	<b>Triple pumps</b> ..... <b>29</b>
6.1	Selection table ..... 29
6.2	Ordering code for triple pumps ..... 30
<b>7</b>	<b>Low-flow capability pump in combination with other QX-single pumps</b> ..... <b>31</b>
7.1	Dimensions [inch] ..... 31
7.2	Ordering code ..... 32

---

8	Fluid cleanliness .....	33
---	-------------------------	----

---

9	Operational reliability .....	33
---	-------------------------------	----

---

10	Note .....	33
----	------------	----

---

11	Accessories .....	34
11.1	Bolt-on valves - SAE J518 code 61 / ISO 6162-1 pattern .....	34
11.2	Pipe flange - high pressure type .....	35
11.3	Pipe flange - low pressure type .....	36



**IMPORTANT:** The main characteristics are valid for hydraulic oils DIN 51524 with a viscosity of 2.15 ... 5.38 ft<sup>2</sup>/s. The operating pressure at the pump outlet side is specified also for fire-resistant and environmentally-friendly fluids (HFC).

## 2.2 Main characteristics for pressure range 1

Displacement effective <sup>1)</sup> [cm <sup>3</sup> /rev] (in <sup>3</sup> /rev)	Flow rate [GPM] 1450 rpm p = 0 PSI	Maximum speed [rpm]	Min. Speed [rpm]	Code	Max. operating pressure at the pump outlet side				Torque <sup>3)</sup> [lb-in]	Input power <sup>4)</sup> [HP]
					continuous [PSI]		intermittent [PSI] <sup>2)</sup>			
					Mineral oil	HFC	Mineral oil	HFC		
10,3 (0.62)	4.62	3600	1200	QX21-010	2320	1885	3045	2610	230	5.4
12.6 (0.76)	5.82			QX21-012	1813	1450	2320	1958	221	5.1
15.9 (0.97)	7.35			QX21-016	1450	1160	1813	1450	221	5.2
20.0 (1.22)	9.25	3000	900	QX31-020	2320	1885	3045	2610	451	10.3
25.2 (1.53)	11.70			QX31-025	1813	1450	2320	1958	443	10.3
31.1 (1.89)	14.42			QX31-032	1450	1160	1813	1450	443	10.1
40.6 (2.47)	18.82	3000	800	QX41-040	2320	1885	3045	2610	921	21.0
50.2 (3.06)	23.25			QX41-050	1813	1450	2320	1958	885	20.7
64.5 (3.93)	29.92			QX41-063	1450	1160	1813	1450	912	20.9
78.3 (4.77)	36.34	2300	800	QX51-080	2320	1885	3045	2610	1770	40.7
100,6 (6.13)	46.74			QX51-100	1813	1450	2320	1958	1779	40.9
126,7 (7.73)	58.85			QX51-125	1450	1160	1813	1450	1767	41.3
159,7 (9.74)	74.20	1800 <sup>6)</sup>	800	QX61-160	2320	1885	3045	2610	3620	83.0
201.1 (12.27)	93.43			QX61-200	1813	1450	2320	1958	3558	81.7
248.4 (15.15)	115.44			QX61-250	1450	1160	1813	1450	3514	80.9
323.9 (19.76)	150.97	1750 <sup>6)</sup>	800	QX81-315	2320	1885	3045	2610	7346	168.8
400.1 (24.41)	186.12			QX81-400	1813	1450	2320	1958	7090	162.9
495.4 (30.23)	158.03			QX81-500	1450	1160	1813	1450	7019	161.5

1) Due to manufacturing tolerances, there may be slight variations in the displacement.

2) Maximum 20 second and not more than 10% of the duty cycle.

3) Theoretical value at the max. permitted continuous pressure for mineral oil.

4) Theoretical value at the max. permitted continuous pressure for mineral oil at n = 1450 rpm.

5) For speeds < 1450 rpm. the inlet pressure of min. 13.77 PSI absolute is required. For HFC application a second suction port is required.

6) Max. speed only possible with a second suction port. see section 2.2.1.

### 2.2.1 Suction arrangements for pump types QX61 and QX81

**IMPORTANT:** Minimum inlet pressure is 14 PSI absolute with viscosity 0.11... 10.76 ft<sup>2</sup>/s (other values on request).

	Speed 1500 rpm suction height		Speed 1800 rpm suction height	
	up to 5.9 in	over 5.9 in	up to 59 in	over 59 in
QX61-160	I	I	I	II
QX61-200	I	I	I	II
QX61-250	I	II	II	II
QX81-315	I	II	II	II
QX81-400	II	II	II	-
QX81-500	II	II	-	-

I = standard pump with one suction port

II = model with two suction ports

All pump types coded II can be used without the second suction port up to 1200 rpm.

### 2.3 Main characteristics for pressure range 2

Displacement effective <sup>1)</sup> [cm <sup>3</sup> /rev] (in <sup>3</sup> /rev)	Flow rate [GPM] 1450 rpm p = 0 PSI	Maximum speed [rpm]	Minimum speed [rpm]	Code	Max. operating pressure at the pump outlet side				Torque <sup>3)</sup> [lb-in]	Input power <sup>4)</sup> [HP]
					continuous [PSI]		Intermittent <sup>2)</sup> [PSI]			
					Mineral oil	HFC	Mineral oil	HFC		
5.1 (0.31)	2.35	3600	1500	QX22-005	3045	2610	3625	3045	150	3.5
6.3 (0.38)	2.91			QX22-006					186	4.3
7.9 (0.48)	3.70			QX22-008					239	5.4
10.0 (0.61)	4.62	3400	1400	QX32-010	3045	2610	3625	3045	301	6.8
12.6 (0.76)	5.82			QX32-012					372	8.6
15.6 (0.95)	7.21			QX32-016					460	10.6
20.3 (1.23)	9.43	3200	1200	QX42-020	3045	2610	3625	3045	602	13.9
25.1 (1.53)	11.6			QX42-025					743	17.0
32.3 (1.97)	14.98			QX42-032					956	22.1
39.1 (2.38)	18.17	2800	1000	QX52-040	3045	2610	3625	3045	1168	26.7
50.3 (3.06)	23.39			QX52-050					1505	34.4
63.4 (3.86)	29.45			QX52-063					1885	43.3
79.8 (4.86)	37.08	2500 <sup>5)</sup>	800	QX62-080	3045	2610	3625	3045	2372	54.5
100.5 (6.13)	46.69	2300 <sup>5)</sup>		2992					68.6	
124.2 (7.57)	57.70	2000 <sup>5)</sup>		3631					85.0	
161.9 (9.87)	75.36	1800 <sup>5)</sup>	800	QX82-160	3045	2610	3625	3045	4815	110.8
200.0 (12.20)	93.06	1750 <sup>5)</sup>		5948					136.8	
247.7 (15.11)	79.00	1500 <sup>5)</sup>		7373					169.5	

### 2.4 Main characteristics for pressure range 3

Displacement effective <sup>1)</sup> [cm <sup>3</sup> /rev] (in <sup>3</sup> /rev)	Flow rate [GPM] 1450 rpm p = 0 PSI	Maximum speed [rpm]	Minimum speed [rpm]	Code	Max. operating pressure at the pump outlet side				Torque <sup>3)</sup> [lb-in]	Input power <sup>4)</sup> [HP]
					continuous [PSI]		intermittent [PSI] <sup>2)</sup>			
					Mineral oil	HFC	Mineral oil	HFC		
5.1 (0.31)	1.96	3600	1400	QX23-005	4640	4060	5800	5075	230	5.7
6.3 (0.38)	2.40			QX23-006					283	6.6
7.9 (0.48)	3.04			QX23-008					363	8.3
10.0 (0.61)	4.62	3400	1100	QX33-010	4640	4060	5800	5075	451	10.3
12.6 (0.76)	5.82			QX33-012					566	13.0
15.6 (0.95)	7.21			QX33-016					708	16.2
20.3 (1.23)	9.43	3200	900	QX43-020	4640	4060	5800	5075	921	21.2
25.1 (1.53)	11.60			QX43-025					1133	26.0
32.3 (1.97)	14.98			QX43-032					1460	33.5
39.1 (2.38)	18.17	2800	800	QX53-040	4640	4060	5800	5075	1770	40.7
50.3 (3.06)	23.39			QX53-050					2284	52.4
63.4 (3.86)	29.45			QX53-063					2841	66.0
79.8 (4.86)	37.08	2500 <sup>5)</sup>	800	QX63-080	4640	4060	5800	5075	3620	83.1
100.5 (6.13)	46.69	2300 <sup>5)</sup>		4549					104.7	
124.2 (7.57)	57.70	2000 <sup>5)</sup>		5629					129.3	
161.9 (9.87)	75.36	1800 <sup>5)</sup>	800	QX83-160	4640	4060	5800	5075	7346	168.8
200.0 (12.20)	93.06	1750 <sup>5)</sup>		9072					208.6	
247.7 (15.11)	79.00	1500 <sup>5)</sup>		11241					258.2	

1) Due to manufacturing tolerances, there may be slight variations in the displacement.

2) Maximum 20 second and not more than 10% of the duty cycle.

3) Theoretical value at the max. permitted continuous pressure for mineral oil.

4) Theoretical value at the max. permitted continuous pressure for mineral oil at n = 1450 rpm:

5) For speeds > 1450 rpm. the inlet pressure of min. 13.77 PSI absolute is required.

## 2.5 Main characteristics for pressure range 4

Displacement effective <sup>1)</sup> [cm <sup>3</sup> /rev] (in <sup>3</sup> /rev)	Flow rate [GPM] 1450 rpm p = 0 PSI	Max. Speed [rpm]	Min. speed [rpm]	Code	Max. operating pressure at the pump outlet side				Torque <sup>3)</sup> [lb-in]	Input power <sup>4)</sup> [HP]
					continuous [PSI]		intermittent [PSI] <sup>2)</sup>			
					Mineral oil	HFC	Mineral oil	HFC		
3.2 (0.19)	1.27	3600	1500	QX24-003	4640	4060	5800	5075	150	3,5
4.2 (0.25)	1.64			QX24-004					186	4,3
5.1 (0.31)	1.96	3600	1400	QX24-005	4640	4060	5800	5075	257	5.9
6.3 (0.38)	2.40			QX24-006					319	7,4
7.9 (0.48)	3.04			QX24-008					407	9,4
10.0 (0.61)	4.62			QX34-010					504	11.7
12.6 (0.76)	5.82	3400	1100	QX34-012	4640	4060	5800	5075	637	14.8
15.6 (0.95)	7.21			QX34-016					788	18.2
20.3 (1.23)	9.43			QX44-020					1036	23.7
25.1 (1.53)	11.6	3200	900	QX44-025	4640	4060	5800	5075	1275	29.2
32.3 (1.97)	14.98			QX44-032					1646	37.8
39.1 (2.38)	18.17	2800	800	QX54-040	4640	4060	5800	5075	1885	43.3
50.3 (3.06)	23.39			QX54-050					2425	55.8
63.4 (3.86)	29.45			QX54-063					3054	70.1
79.8 (4.86)	37.08			2500 <sup>5)</sup>					3726	85.8
100.5 (6.13)	46.69	2300 <sup>5)</sup>	800	QX64-080	4640	4060	5800	5075	4691	108.0
124.2 (7.57)	57.70	2000 <sup>5)</sup>		QX64-100					5797	133.4
161.9 (9.87)	75.36	1800 <sup>5)</sup>	800	QX84-160	4640	4060	5800	5075	7576	174.3
200.0 (12.20)	93.06	1750 <sup>5)</sup>		QX84-200					9355	215.2
247.7 (15.11)	79.00	1500 <sup>5)</sup>		QX84-250					11586	266.5

1) Due to manufacturing tolerances, there may be slight variations in the displacement.

2) Maximum 20 second and not more than 10% of the duty cycle.

3) Theoretical value at the max. permitted continuous pressure for mineral oil.

4) Theoretical value at the max. permitted continuous pressure for mineral oil at n = 1450 rpm.

5) For speeds > 1450 rpm. the inlet pressure of min. 13.77 PSI absolute is required..

### 3 Performance graphs

**IMPORTANT:** The performance graphs shown are valid for the specified pump models.  
For other pump sizes, contact Bucher Hydraulics GmbH.

#### 3.1 Noise level (Lp)

measured to DIN 45635, Part 26, in Stuttgart University's low-echo noise measurement chamber:  
measurement distance 1 m  
speed  $n = 1500$  rpm  
viscosity = 210 S.U.S

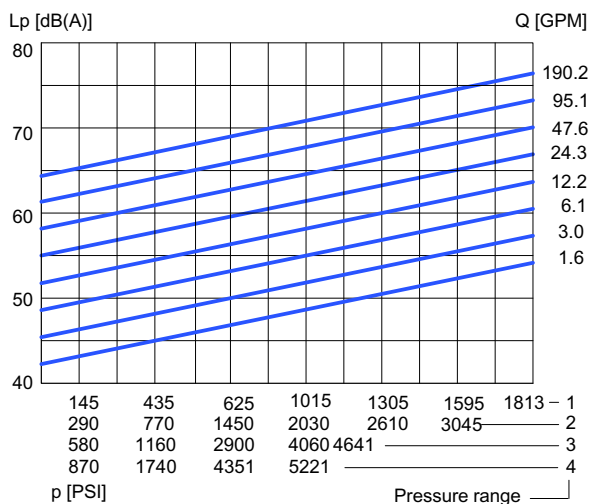

\* Max. continuous operating pressure for pressure range 4 see section 2.5

#### 3.2 Efficiency ( $\eta$ )

measured at speed 1450 rpm, viscosity 210 S.U.S

##### 3.2.1 Pressure range 1

###### 3.2.1.1 Volumetric efficiency

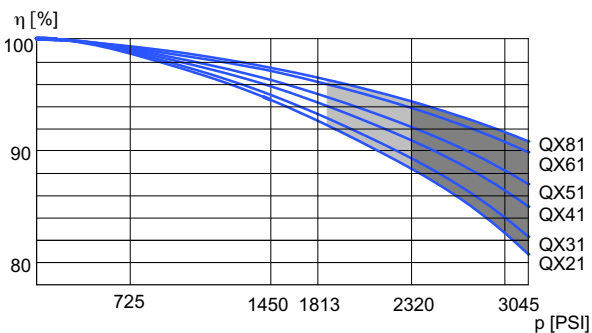

intermittent operating pressure as a function of displacement (see section 2.2)

###### 3.2.1.2 Hydromechanical efficiency

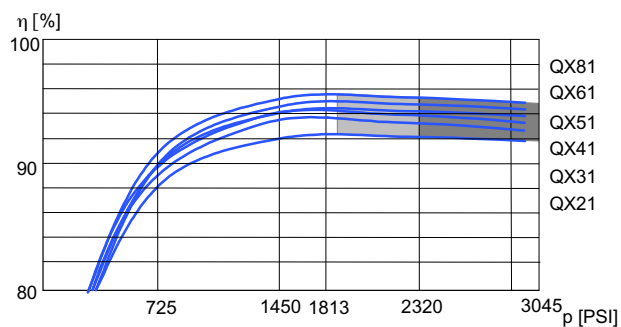

**3.2.2 Pressure range 2**

**3.2.2.1 Volumetric efficiency**

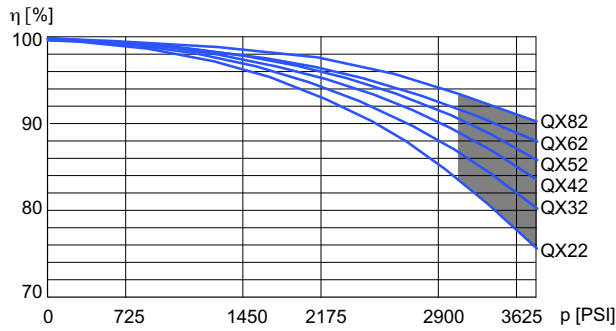

intermittent operating pressure

**3.2.2.2 Hydromechanical efficiency**

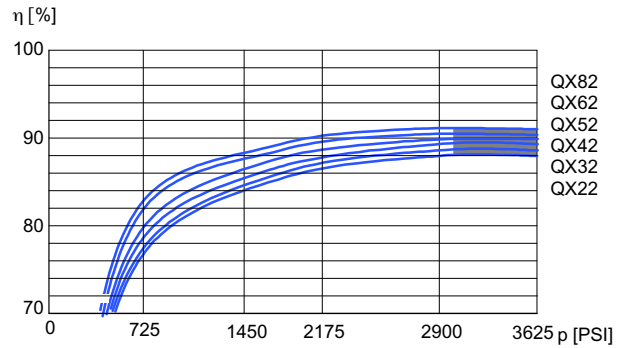

**3.2.3 Pressure range 3**

**3.2.3.1 Volumetric efficiency**

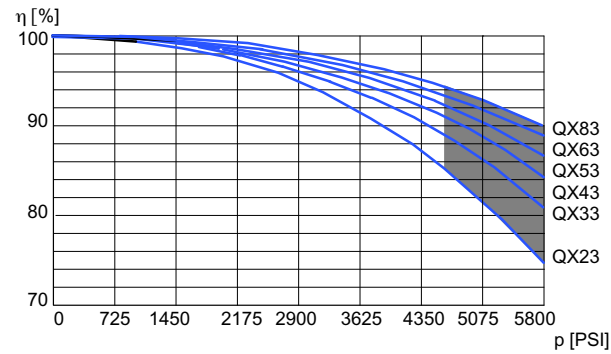

intermittent operating pressure

**3.2.3.2 Hydromechanical efficiency**

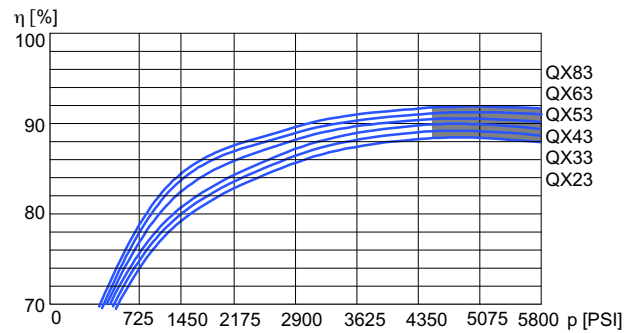

**3.2.4 Pressure range 4**

**3.2.4.1 Volumetric efficiency**

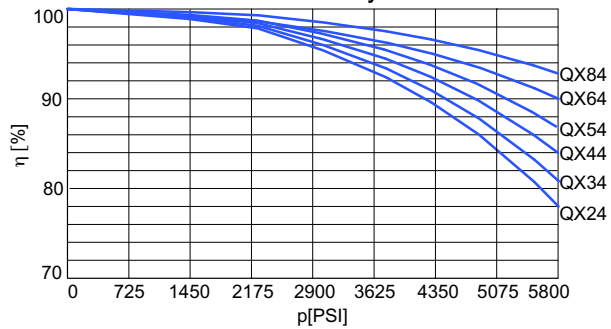

**3.2.4.2 Hydromechanical efficiency**

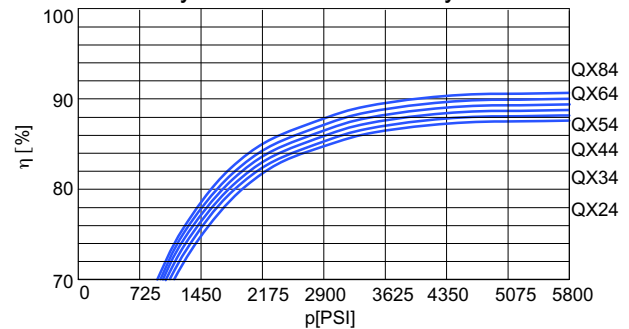

### 3.3 Operation with variable-speed drives

**IMPORTANT:** The following main characteristics are to be understood as examples only. They are valid only for the specified pump models and parameters. We would be very happy to advise you on the layout of your drive. QX pumps with variable-speed drive all contain an external drain port.

#### 3.3.1 Typical loading cycle for a QX pump with variable-speed drive

Pump QX53-063 measured: with viscosity 210 S.U.S

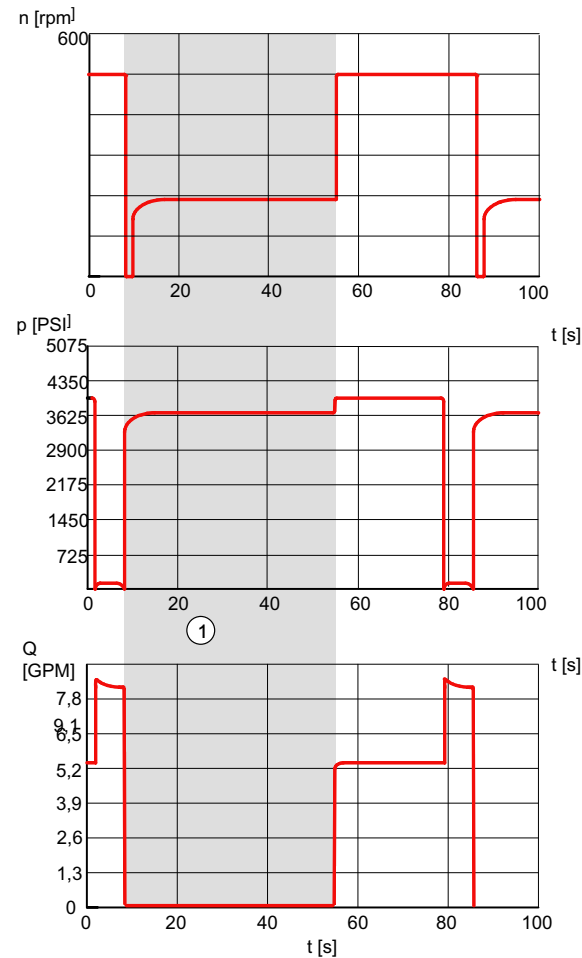

1	pressure-holding operation $Q = 0$ GPM for up to 60 s
---	--

#### 3.3.2 Minimum speed as a function of pressure

Pump QX53-063 measured: with viscosity 210 S.U.S

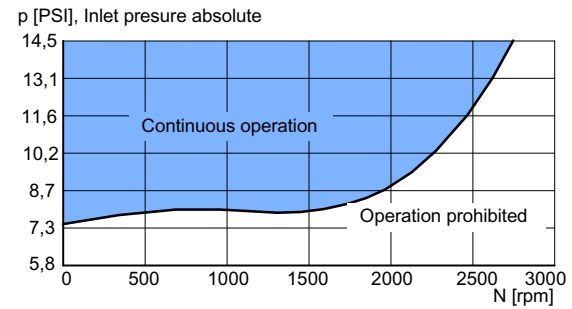

#### 3.3.3 Minimum pressure at suction port as a function of speed

Pump QX53-063 measured with viscosity 210 S.U.S

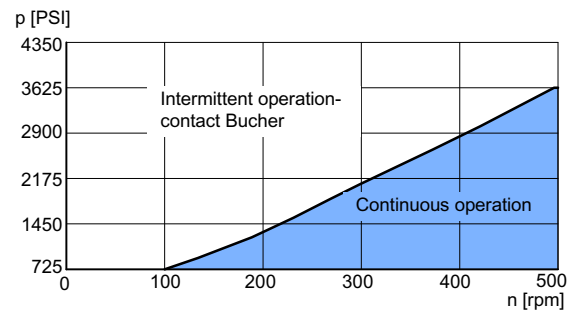

## 4 Single pumps

### 4.1 Dimensions [inch] frame size 2 - 4

Frame size		2				3				4			
Pressure range		1	2	3	4 <sup>5)6)</sup>	1	2	3	4	1	2	3	4
Suction port: to SAE J518 <sup>1)</sup>	S	G1" thread <sup>3)</sup>				G1¼" thread <sup>3)</sup>				1½"			
Pressure port: to SAE J518 <sup>1)</sup>	P	G½" thread <sup>3)</sup> optional SAE J518 <sup>4)</sup>				G¾" thread <sup>3)</sup> optional SAE J518 <sup>4)</sup>				1"			
Mounting: oval 2-hole flange to ISO 3019/1 (SAE) ISO 3019/2 (metric)	A	7.15				5.20				6.70			
	B (SAE)	-				4.17				5.75			
	B (Metr.)	3.93				4.29				5.51			
	C	0.35				0.43				0.55			
	N (SAE)	-				3.25 <sub>-0,002</sub>				4 <sub>-0,002</sub>			
	N (Metr.)	2.48 (h8)				3.15 (h8)				3.93 (h8)			
	O	0.33				0.33				0.41			
	V	0.24				0.24				0.28			
4-hole flange ISO 3019/2	X (Metr.)	0.35				0.35				0.47			
	Y (Metr.)	3.35				4.06				4.92			
Shaft end: parallel, to ISO/R775 <sup>2)</sup>	D	0.79 (j6)				0.98 (j6)				1.26 (j6)			
	E	1.42				1.65				2.28			
	F	0.24				0.31				0.39			
	G	0.89				1.10				1.38			
	I	1.77				1.97				2.68			
Housing	K	1.49				1.73				2.04			
	L	5.4	4.6	6.0	7.5	6.5	5.7	7.4	9.1	7.9	6.9	9.1	11.2
	M	-	2.2	3.4	4.9	-	2.7	4.5	6.3	-	3.4	5.6	7.8
	T1	1.69				2.12				2.63			
	T2	1.69				2.12	2.36			2.63	2.75		
	Z	3.93				4.72				4.92			
	W	3.15				3.93				5.35			
	Weight	lbs	13.2	13.2	15.4	17.6	22	22	28.7	33.1	44.1	39.7	48.5

- 1) Pipe flange dimensions, SAEJ518 code 61 / ISO 6162-1.  
High pressure type up to 6090 PSI see section 12.2, low pressure type for up to 232 PSI see section 12.3.
- 2) For other shaft ends. contact Bucher Hydraulics GmbH.
- 3) Threaded port to DIN 3852. Part 2.
- 4) Option 117: Pressure port to SAEJ518 code 61 / ISO 6162-1 can be supplied for pressure ranges 2+3 (see section 4.8.3).
- 5) The dimensions are not valid for low-flow capability pumps (0.20 in<sup>3</sup>/rev and 0.25 in<sup>3</sup>/rev see chapter 4.7).
- 6) Internal gear pumps size 2 with low-flow capability (0.20 in<sup>3</sup>/rev and 0.25 in<sup>3</sup>/rev) are supplied with external drain port (option 06) as standard.

## 4.2 Dimensions [inch] frame size 5 - 8

Frame size		5				6				8			
Pressure range		1	2	3	4	1	2	3	4	1	2	3	4
Suction port: to SAE J518 <sup>1)</sup>	S	2"				2½"				3"			
Pressure port: to SAE J518 <sup>1)</sup>	P	1¼"				1½"				2"			
Mounting: oval 2-hole flange to ISO 3019/1 (SAE) ISO 3019/2 (metric)	A	8.35				10.51				12.99			
	B (SAE)	7.13				9.02				-			
	B (Metr.)	7.09				8.82				11.02			
Mounting: oval 2-hole flange to ISO 3019/1 (SAE) ISO 3019/2 (metric)	C	0.71				0.87				1.02			
	N (SAE)	5 <sub>-0,002</sub>				6 <sub>-0,002</sub>				-			
	N (Metr.)	4.92 (h8)				6.30 (h8)				7.87 (h8)			
	O	0.49				0.65				0.79			
	V	0.28				0.28				0.35			
4-hole flange ISO 3019/2	X (Metr.)	0.55				0.71				0.87			
	Y (Metr.)	6.30				7.87				9.84			
Shaft end: parallel, to ISO/R775 <sup>2)</sup>	D	1.57 (j6)				1.97 (j6)				2.48 (j6)			
	E	3.23				3.23				4.13			
	F	0.47				0.55				0.71			
	G	1.69				2.10				2.64			
	I	3.62				3.62				4.61			
Housing	K	2.36				2.91				3.54			
	L	9.5	8.3	11.0	13.7	11	9.8	13	16.7	14	13	16.7	21.3
	M	-	4.0	6.8	9.5	-	4.7	8.2	11.7	-	5.9	10.4	15
	T1	3.5				4.21	4.33			5.39	5.43		
	T2	3.5				4.21	4.33			5.39	5.43		
	Z	6.1				7.6				9.84			
	W	6.5			6.1	8.0				10.1			
Weight	lbs	79.4	70.5	90.4	110.2	141.1	125.7	169.8	198.4	286.6	260.1	352.7	440.9

- 1) Pipe flange dimensions, SAEJ518 code 61 / ISO 6162-1.  
High pressure type up to 6090 PSI see section 12.2, low pressure type for up to 232 PSI (see section 12.3).
- 2) For other shaft ends. contact Bucher Hydraulics GmbH.

4.3 Pressure range 1

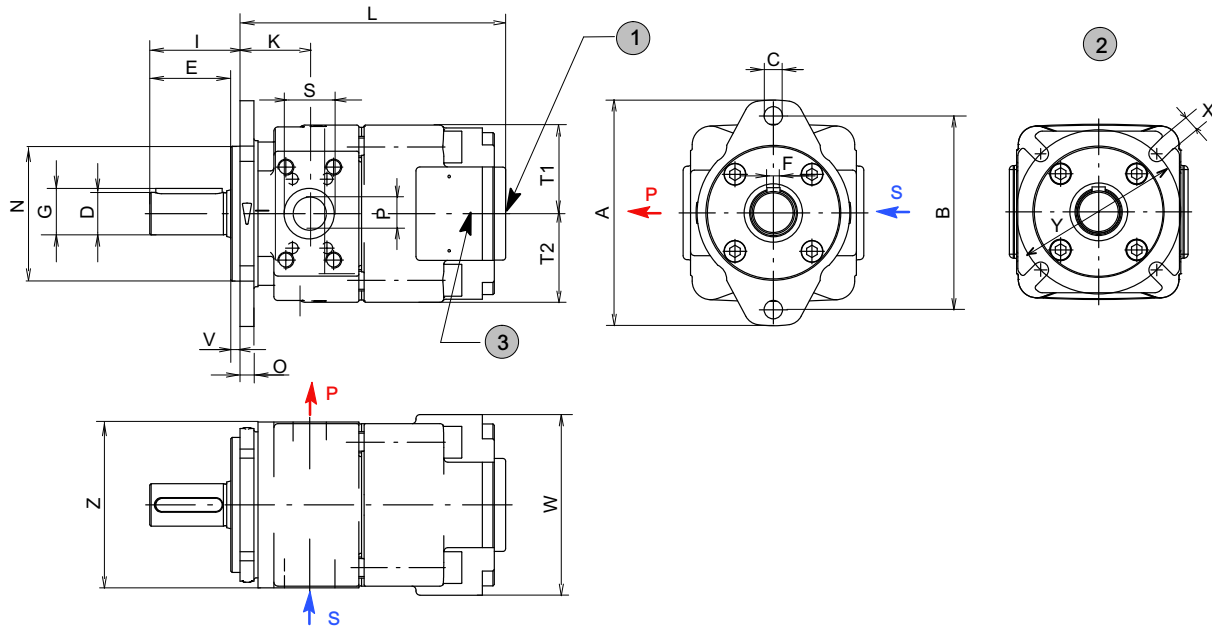

1	option 06 = external drain port
2	option 66 = special model 4-hole flange ISO 3019/2

3	option 83 = depending on operating conditions, a second suction port may be required on: QX51=SAE 1¼", QX61=SAE 2"; QX81=SAE 2½" - see section 2.2.1
---	--

4.4 Pressure range 2

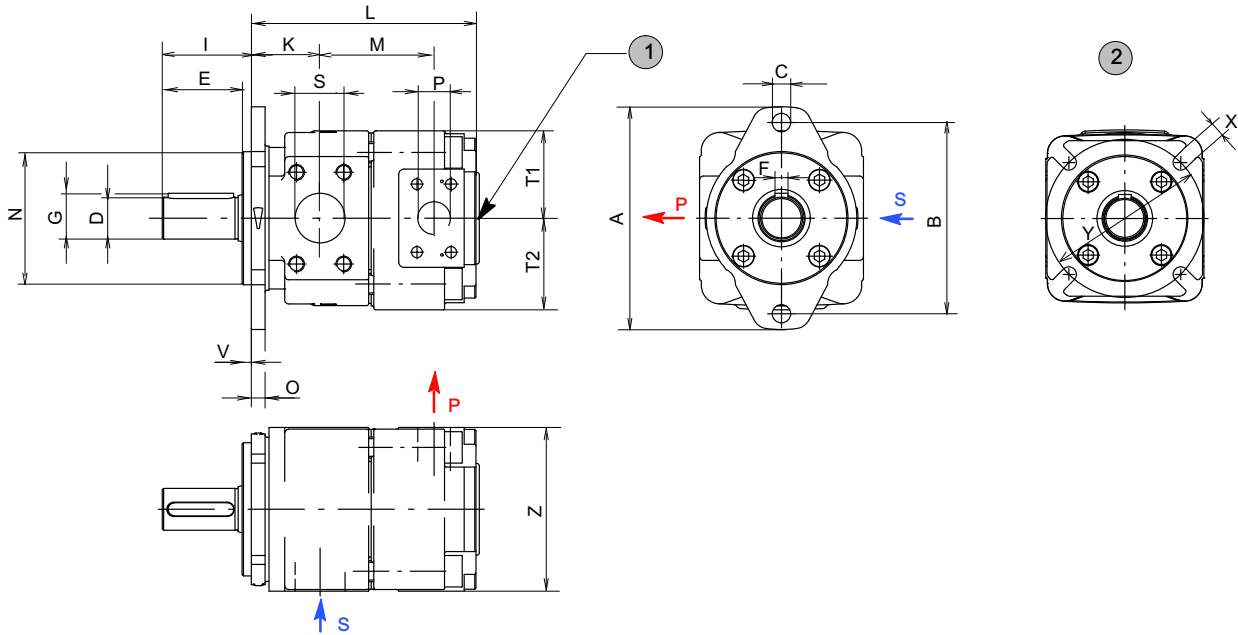

1	option 06 = external drain port
---	---------------------------------

2	option 66 = special model 4-hole flange ISO 3019/2
---	--

4.5 Pressure range 3

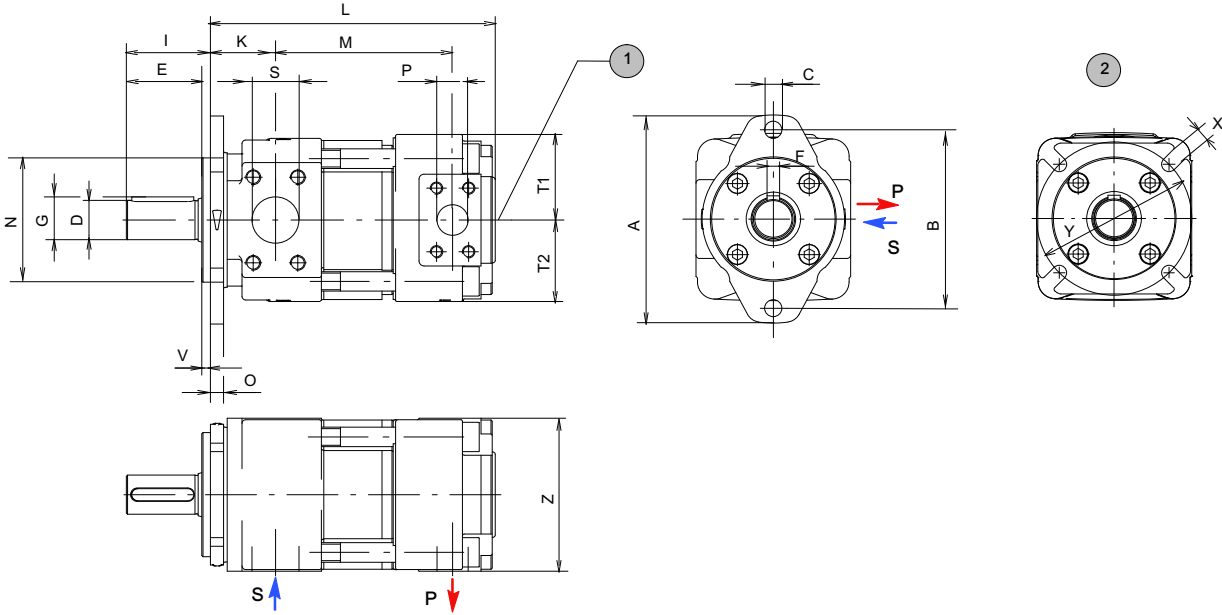

1 option 06 = external drain port

2 option 66 = special model 4-hole flange ISO 3019/2

4.6 Pressure range 4

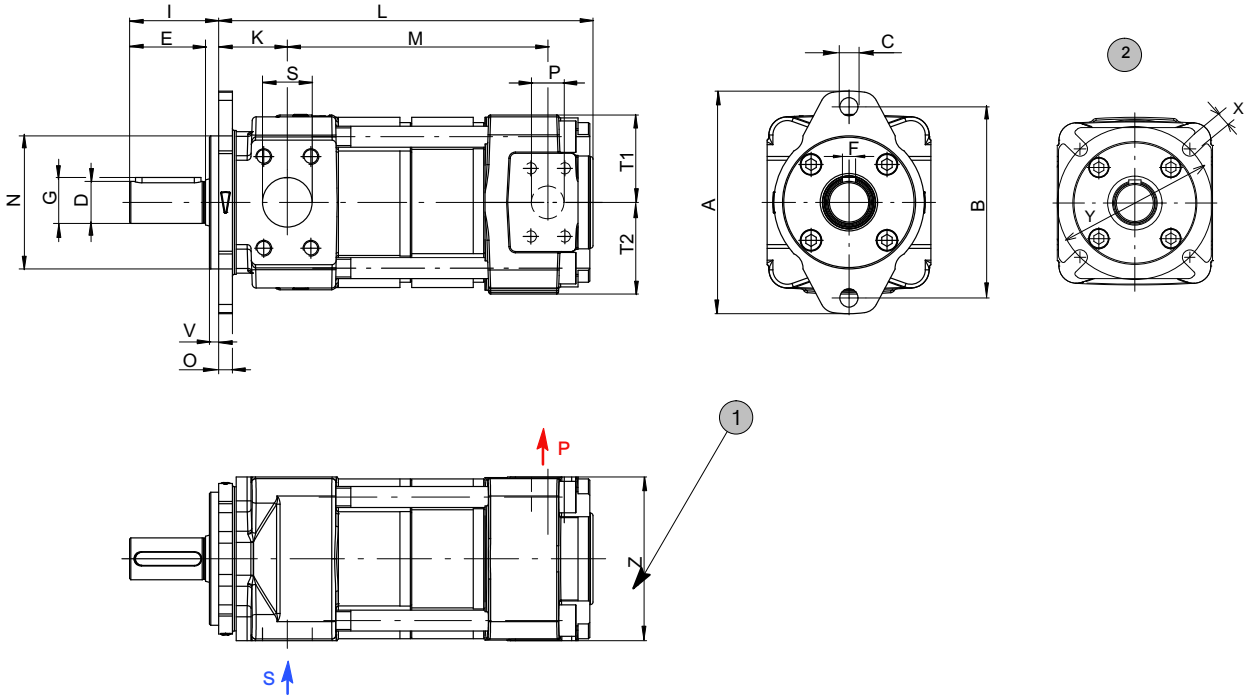

1 option 06 = external drain port

2 option 66 = special model 4-hole flange ISO 3019/2

### 4.7 Pressure range 4 with low-flow capability

QX24 with displacements from 3 and 4 cm<sup>3</sup>/U (0.18 and 0.24 in<sup>3</sup>/rev).

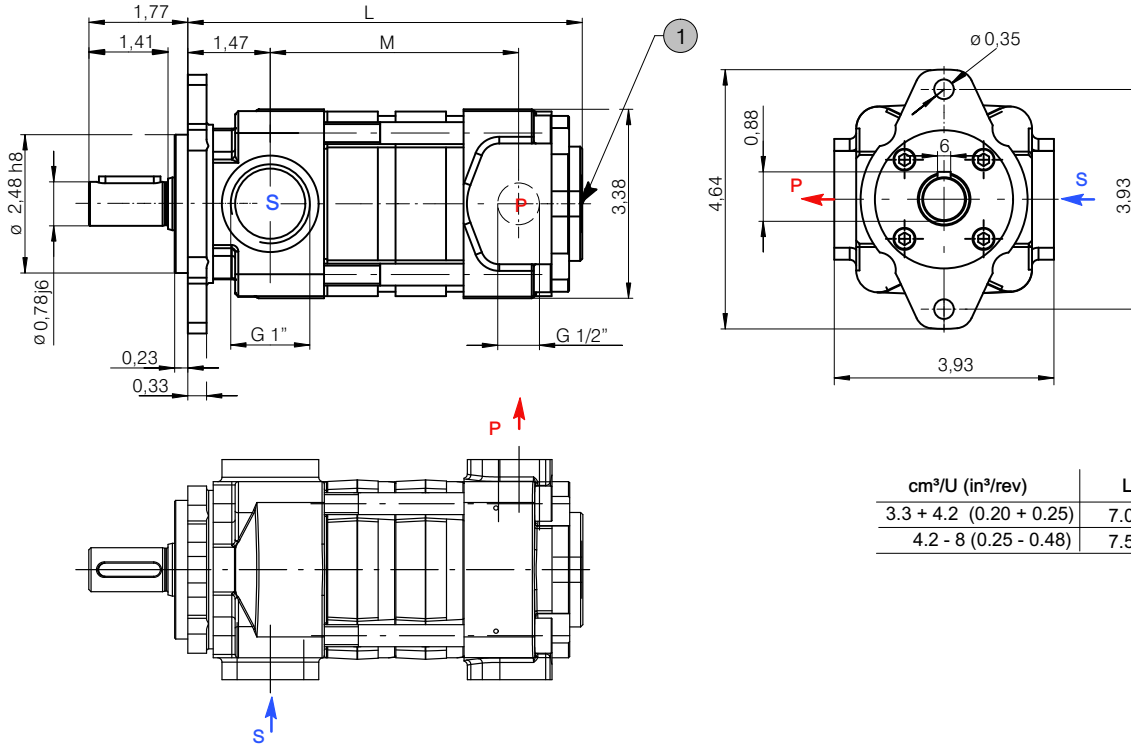

cm <sup>3</sup> /U (in <sup>3</sup> /rev)	L	M
3.3 + 4.2 (0.20 + 0.25)	7.06	4.44
4.2 - 8 (0.25 - 0.48)	7.53	4.92

1	Pump version only with option 06 (external drain port)
---	--

## 4.8 Ordering code for single pumps

		Q X 5 3 - 0 4 0 R * *
Series	= QX	
Frame size	= 2 / 3 / 4 / 5 / 6 / 8	
Pressure range	= 1 / 2 / 3 / 4	
Displacement [cm <sup>3</sup> /rev]	= 3.2 - 495.4 (0.19 - 30.23 in <sup>3</sup> /rev)	
Rotation viewed from shaft end	CW (right) = R (standard) CCW (left) = L	
Option	see section 4.8.3	

### 4.8.1 Ordering example

Required: single pump  
 Displacement: 40 cm<sup>3</sup>/rev (2.40 in<sup>3</sup>/rev)  
 Continuous pressure: 300 bar (4350 PSI)  
 for use with mineral oil  
 Ordering code: QX53-040R

### 4.8.2 Standard configuration

- direction of rotation - CW (right)
- 2-hole mounting flange to ISO 3019/1 (SAE): sizes QX 3-6
- 2-hole mounting flange to ISO 3019/2 (metr.): sizes QX 2 and 8
- Nitrile seals
- cylindrical shaft end to ISO/R775
- black priming, flange without priming

### 4.8.3 Option

- O = without priming
- 06 = external drain port in the pump rear cover
  - QX 2-5 = G<sup>1</sup>/<sub>4</sub>"
  - QX 6 = G<sup>3</sup>/<sub>8</sub>"
  - QX 8 = G<sup>1</sup>/<sub>2</sub>"
- 09 = FKM (Viton) seals
- 12 = 2-hole mounting flange to ISO 3019/2 (metric): size QX3-6
- 29 = for HFB and HFC fluids, frame sizes 2-5, without priming
- 66 = 4-hole mounting flange to ISO 3019/2 (metric)
- 83 = second suction port on:
  - QX51 = SAE 1<sup>1</sup>/<sub>4</sub>"
  - QX61 = SAE 2"
  - QX81 = SAE 2<sup>1</sup>/<sub>2</sub>"
- 117 = pressure port to SAE J518 code 61 / ISO 6162-1 can be supplied for frame size 2+3 with pressure ranges 2+3

Further options on request.



## 5.2 Dimensions [inch]

### A Double pumps QX.1/1.1

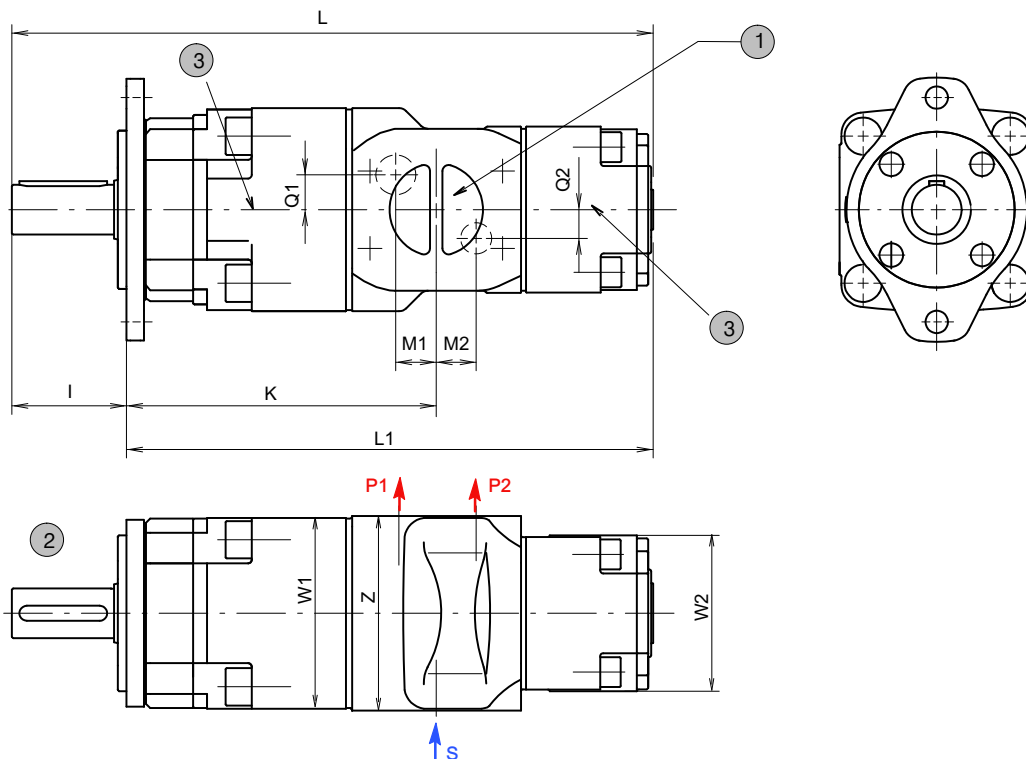

1	S = common suction port
2	shaft and mounting dimensions see section 4

3	option 83 = depending on operating conditions, a second suction port may be required - see section 2.2.1: QX51=SAE 1¼", QX61=SAE 2", QX81=SAE 2½"
---	---

Type	L	L1	K	M1	M2	Q1	Q2	I	Z	W1	W2	S	P1	P2
QX21/21	11.59	9.82	5.55	0.71	0.71	-	-	1.77	3.93	3.15	3.15	G1¼" 1)	G½" 1) 2)	G½" 1) 2)
QX31/21	13.46	11.49	6.73	1.02	1.18			1.97	4.72	3.93	3.15	3.93	3.93	G1½" 1)
QX31/31	14.01	12.04			1.02	1.02	1.37	2.68	4.92	5.35	3.93			
QX41/21	15.54	12.85	7.97	0.75	1.30	0.59	0.59					5.35	SAE 2"	SAE 1"
QX41/31	16.10	13.42			1.02	1.02	0.91	0.91	5.35	SAE 2"	SAE 1"	SAE 1"		
QX41/41	17.59	14.92	8.19	1.02	1.02	0.91	0.91	5.35	SAE 2"	SAE 1"	SAE 1"			
QX51/21	18.36	14.74	9.49	0.90	1.69	0.59	-	3.62	6.14	6.49	3.15	SAE 2½"	SAE 1¼"	G½" 1) 2)
QX51/31	18.93	15.31			1.54	0.59	0.59				3.93			G¾" 1) 2)
QX51/41	20.43	16.81	9.80	1.18	1.26	1.10	0.91	3.62	7.67	7.99	5.35	SAE 3"	SAE 1½"	SAE 1"
QX51/51	21.47	17.85			1.18	1.10	1.10				6.49			SAE 1¼"
QX61/31	21.24	17.61	11.3	0.94	1.85	0.67	0.55	3.62	7.67	7.99	3.93	SAE 3"	SAE 1½"	G¾" 1) 2)
QX61/41	22.14	18.52			1.06	1.02	1.06				5.35			SAE 1"
QX61/51	23.58	19.96	11.5	1.26	1.57	1.37	1.10	3.62	7.67	7.99	6.49	SAE 3"	SAE 1½"	SAE 1¼"
QX61/61	24.64	21.02			1.26	1.37	1.37				7.99			SAE 1½"
QX81/41	26.65	22.04	14.1	1.38	2.00	0.98	0.98	4.61	9.84	250	5.35	SAE 3½"	SAE 2"	SAE 1"
QX81/51	27.69	23.09			1.85	1.18	1.18				6.49			SAE 1¼"
QX81/61	28.76	24.15		1.77	1.37	1.37	7.99				SAE 1½"			
QX81/81	30.41	25.80		1.49	1.57	1.57	10.07				SAE 2"			

1) Threaded port to DIN 3852 Part 2.

2) Pressure port to SAE J 518 can be supplied for pressure ranges 2+3.

## B Double pumps QX.1/2

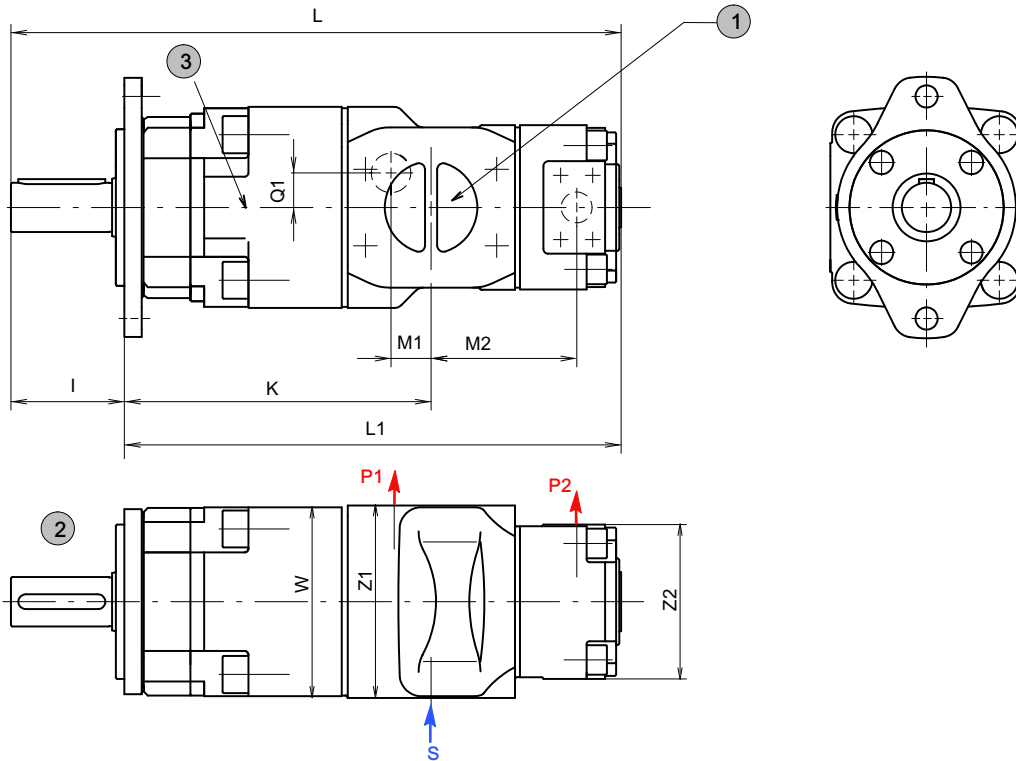

1	S = common suction port
2	shaft and mounting dimensions see section 4

3	option 83 = depending on operating conditions, a second suction port may be required - see section 2.2.1: QX51=SAE 1¼", QX61=SAE 2", QX81=SAE 2½"
---	---

Type	L	L1	K	M1	M2	Q1	I	Z1	Z2	W	S	P1	P2
QX21/22	10.88	9.11	5.6	0.7	2.6	-	1.8	3.93	3.93	3.15	G 1¼" 1)	G ½" 1) 2)	G ½" 1) 2)
QX31/22	12.75	10.78	6.7	1.0	3.1		2.0	4.72		3.93	3.93	G 1½" 1)	
QX31/32	13.24	11.28				3.4			0.6				2.7
QX41/22	14.82	12.14	7.9	0.75	3.3	0.9	4.92	4.92		SAE 2"	SAE 1"	G ½" 1) 2)	
QX41/32	15.33	12.65			3.6				0.6			3.6	0.6
QX41/42	16.57	13.89	8.2	1.02	4.4	0.6	3.6	6.14		SAE 2½"	SAE 1¼"		
QX51/22	17.65	14.03	9.5	0.9	3.6				0.6			3.6	6.14
QX51/32	18.18	14.56			3.9	1.1	4.6	1.1		3.6	6.14		
QX51/42	19.40	15.78	9.8	1.2	5.0				1.1			3.6	7.67
QX51/52	20.21	16.59			5.9	1.4	5.4	1.4		3.6	7.67		
QX61/32	20.47	16.85	11.3	0.9	4.4				0.7			3.6	7.67
QX61/42	21.12	17.50		1.1	4.8	0.8	3.6	7.67	7.99	7.99	SAE 3"		
QX61/52	22.32	18.70	11.5	1.3	5.4	1.4						3.6	7.67
QX61/62	23.07	19.44			5.9		1.4	5.4	1.4	3.6	7.67		
QX81/42	25.63	21.02	14.1	1.4	5.6	1.0						4.6	9.84
QX81/52	26.41	21.81			5.9		1.0	5.4	1.0	4.6	9.84		
QX81/62	27.18	22.57	14.1	1.5	6.4	1.6						4.6	9.84
QX81/82	28.52	23.91			7.0		1.6	7.0	1.6	4.6	9.84		

1) Threaded port to DIN 3852. Part 2.

2) Pressure port to SAE J 518 can be supplied for pressure ranges 2+3.

**C Double pumps QX.1/3**

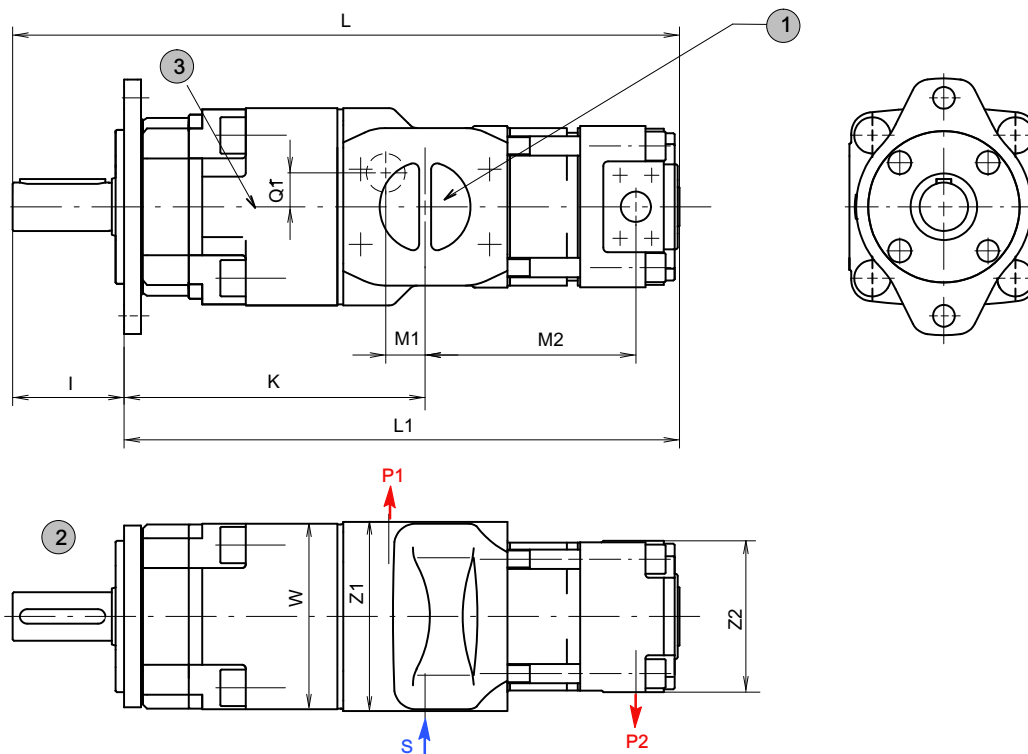

<b>1</b>	S = common suction port
<b>2</b>	shaft and mounting dimensions see section 4

<b>3</b>	option 83 = depending on operating conditions, a second suction port may be required - see section 2.2.1: QX51= 1¼", QX61=SAE 2", QX81=SAE 2½"
----------	--

Type	L	L1	K	M1	M2	Q1	I	Z1	Z2	W	S	P1	P2
QX21/23	12.26	10.49	5.6	0.7	4.0	-	1.8	3.93	3.93	3.15	G 1¼" 1)	G ½" 1) 2)	G ½" 1) 2)
QX31/23	14.11	12.14	6.7	1.0	4.5		2.0	4.72	3.93	3.93	G 1½" 1)	G ¾" 1) 2)	G ¾" 1) 2)
QX31/33	15.03	13.07			5.2	0.6	2.7	4.92	3.93	5.35	SAE 2"	SAE 1"	G ½" 1) 2)
QX41/23	16.22	13.54	7.9	0.75	4.7	0.6	2.7	4.92	4.72	5.35	SAE 2"	SAE 1"	G ¾" 1) 2)
QX41/33	17.10	14.42			5.4				4.92				SAE 1"
QX41/43	18.78	16.10	8.2	1.02	6.6	0.9	3.6	6.14	3.93	6.49	SAE 2½"	SAE 1¼"	G ½" 1) 2)
QX51/23	19.05	15.43	9.5	0.9	5.0	0.6			4.72				G ¾" 1) 2)
QX51/33	19.94	16.31			5.7	1.1	3.6	6.14	4.92	6.14	7.99	SAE 3"	SAE 1½"
QX51/43	21.61	17.99	9.8	1.2	6.9	0.7			4.72				
QX51/53	22.97	19.35			7.8	0.8	3.6	7.67	4.92	7.99	SAE 3"	SAE 1½"	SAE 1¼"
QX61/33	22.24	18.62	11.3	0.9	6.2	0.7			6.14				
QX61/43	23.32	19.70			1.1	7.0	0.8	4.92	SAE 1"				
QX61/53	25.07	21.45	11.5	1.3	8.1	1.4	3.6	7.67	6.14	7.99	SAE 3½"	SAE 1½"	SAE 1¼"
QX61/63	26.61	22.99			9.4				7.75				SAE 1½"
QX81/43	27.83	23.22	14.1	1.4	7.8	1.0	4.6	9.84	4.92	10.07	SAE 3½"	SAE 2"	SAE 1"
QX81/53	29.19	24.58			8.7				6.14				SAE 1¼"
QX81/63	30.72	26.12			9.9	7.75			SAE 1½"				
QX81/83	33.05	28.44			1.5	11.6			1.6				9.84

1) Threaded port to DIN 3852. Part 2.

2) Pressure port to SAE J 518 can be supplied for pressure ranges 2+3.

## D Double pumps QX.2/1

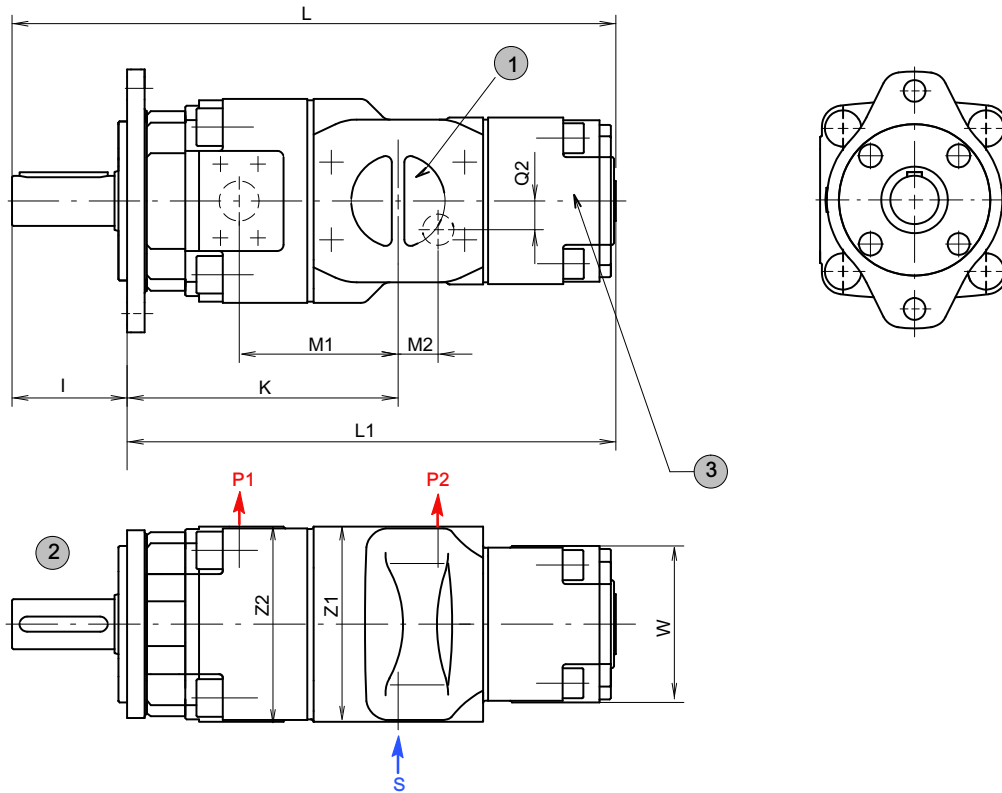

1	S = common suction port
2	shaft and mounting dimensions see section 4

3	option 83 = depending on operating conditions, a second suction port may be required - see section 2.2.1: QX51=SAE 1¼", QX61=SAE 2"
---	--

Type	L	L1	K	M1	M2	Q2	I	Z1	Z2	W	P1	P2	
QX32/21	12.67	10.70	5.9	3.4	1.2	-	2.0	4.72	4.72	3.15	G ¾" 1) 2)	G ½" 1) 2)	
QX42/21	14.52	11.85	6.9	4.1	1.4	0.6	2.7	4.92	4.92	3.93	SAE 1"	G ¾" 1) 2)	
QX42/31	15.07	12.40			1.3								
QX52/21	17.10	13.48	8.2	4.7	1.7	-	3.6	6.14	6.14	3.15	SAE 1¼"	G ½" 1) 2)	
QX52/31	17.67	14.05			1.5					0.6		3.93	G ¾" 1) 2)
QX52/41	19.17	15.55			1.3					0.9		5.35	SAE 1"
QX62/31	19.66	16.04	9.7	5.7	1.9	0.5	3.6	7.67	7.75	3.93	SAE 1½"	G ¾" 1) 2)	
QX62/41	20.57	16.94			1.5					1.1		5.35	SAE 1"
QX62/51	22.00	18.38			1.6					1.1		6.49	SAE 1¼"
QX82/41	24.68	20.07	12.2	7.0	2.0	1.0	4.6	9.84	9.84	5.35	SAE 2"	SAE 1"	
QX82/51	25.72	21.12			1.9					1.2		6.49	SAE 1¼"
QX82/61	26.79	22.18			1.8					1.4		7.99	SAE 1½"

1) Threaded port to DIN 3852. Part 2.

2) Pressure port to SAE J 518 can be supplied for pressure ranges 2+3.

**E Double pumps QX.2/1.2**

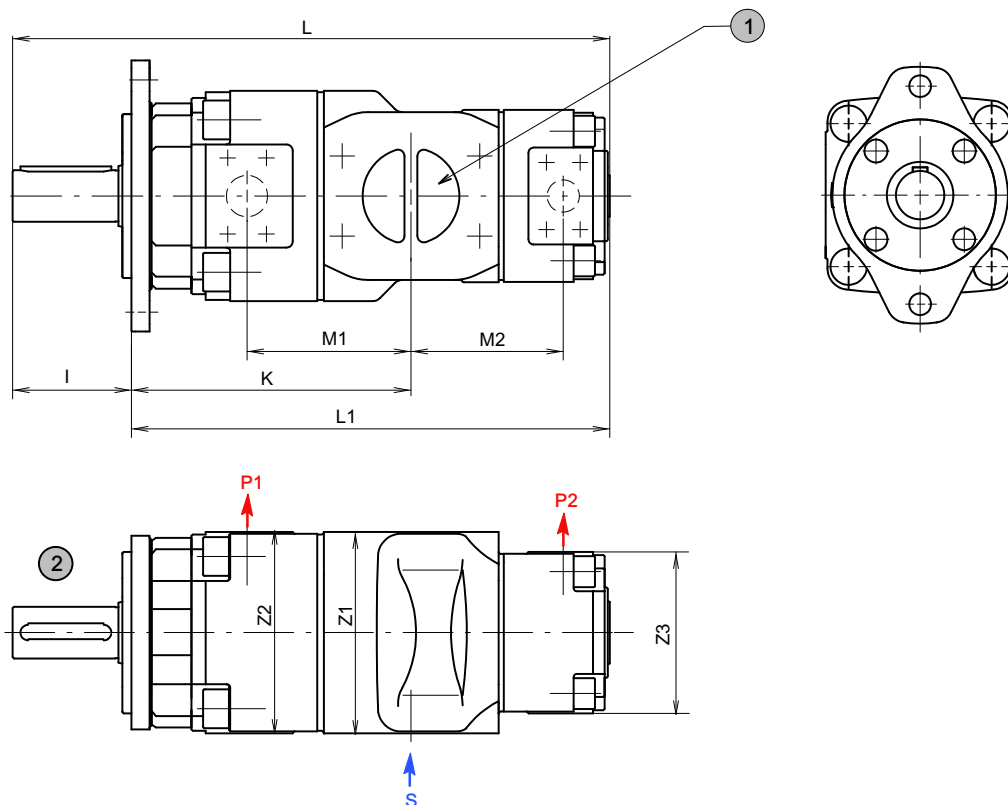

**1** S = common suction port

**2** shaft and mounting dimensions - see section 4

Type	L	L1	K	M1	M2	I	Z1	Z2	Z3	S	P1	P2
QX22/22	10.17	8.40	4.8	2.6	2.6	1.8	3.93		3.93	G1¼" 1)	G½" 1) 2)	G½" 1) 2)
QX32/22	11.96	10.00	5.9	3.4	3.1	2.0	4.72			4.72	G1½" 1)	
QX32/32	12.48	10.51			3.4		4.92		4.92			SAE 2"
QX42/22	13.81	11.14	6.9	4.1	3.3	2.7	4.92			4.92	SAE 2"	
QX42/32	14.31	11.63			3.6		4.92		4.92			SAE 2"
QX42/42	15.11	12.87	7.2	4.4	4.4	3.6	6.14			3.93	SAE 2½"	
QX52/22	16.39	12.77			4.7		3.6	3.6	6.14			4.72
QX52/32	16.90	13.28	8.2	5.0	3.9	6.14			4.92	SAE 2½"	SAE 1¼"	
QX52/42	18.15	14.52			5.0	4.6	3.6	6.14				6.14
QX52/52	18.97	15.35	8.5	5.0	5.0	6.14		6.14	SAE 3"	SAE 1¼"	SAE 1"	
QX62/32	18.89	15.27			9.7	5.7	4.4					3.6
QX62/42	19.54	15.92	4.8	4.92			4.92	SAE 3"	SAE 1½"	SAE 1"		
QX62/52	20.74	17.12	9.9	5.9	5.4	3.6					7.75	
QX62/62	21.49	17.87			5.9		7.75		7.75	SAE 3½"	SAE 1½"	7.75
QX82/42	23.66	19.05	12.2	7.0	5.6	4.6	9.84					
QX82/52	24.46	19.86			5.9		9.84		9.84	SAE 4"	SAE 2"	6.14
QX82/62	25.21	20.61	6.4	9.84		9.84	SAE 4"	SAE 2"				
QX82/82	26.55	21.94	7.0	9.84					9.84	SAE 4"	SAE 2"	9.84

1) Threaded port to DIN 3852 Part 2.

2) Pressure port to SAE J 518 can be supplied for pressure ranges 2+3.

## F Double pumps QX.2/3

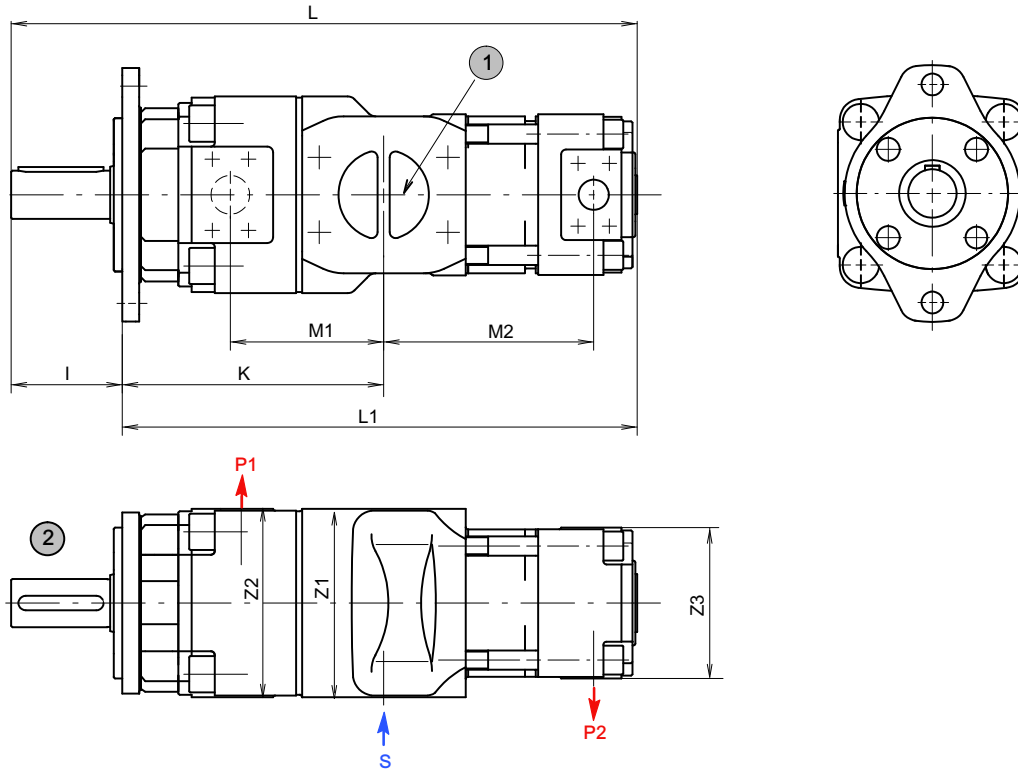

**1** S = common suction port

**2** shaft and mounting dimensions - see section 4

Type	L	L1	K	M1	M2	I	Z1	Z2	Z3	S	P1	P2
QX32/23	13.34	11.37	5.9	3.4	4.5	2.0	4.72		3.93	G1½" 1)	G¾" 1) 2)	G½" 1) 2)
QX42/23	15.19	12.52	6.9	4.1	4.7	2.7	4.92			4.72	SAE 2"	
QX42/33	16.14	13.46			5.4				3.6			6.14
QX52/23	17.79	14.17	8.2	4.7	5.0	3.6	6.14			4.92	SAE 1¼"	
QX52/33	18.68	15.05			5.7				6.9			7.67
QX52/43	20.35	16.73	9.7	5.7	6.2	3.6	9.84			4.92	SAE 3"	
QX62/33	20.66	17.04			7.0				8.1			6.14
QX62/43	21.75	18.13	9.9	5.9	8.1	3.6	9.84			6.14	SAE 3½"	
QX62/53	23.50	19.88			7.8				8.7			7.75
QX82/43	25.86	21.26	12.2	7.0	8.7	4.6	9.84			6.14	SAE 4"	
QX82/53	27.22	22.61			9.9				8.9			7.75
QX82/63	28.76	24.15	7.8	8.9	7.75	9.84		7.75		SAE 4"	SAE 2"	

1) Threaded port to DIN 3852. Part 2.

2) Pressure port to SAE J 518 can be supplied for pressure ranges 2+3.

**G Double pumps QX.3/1**

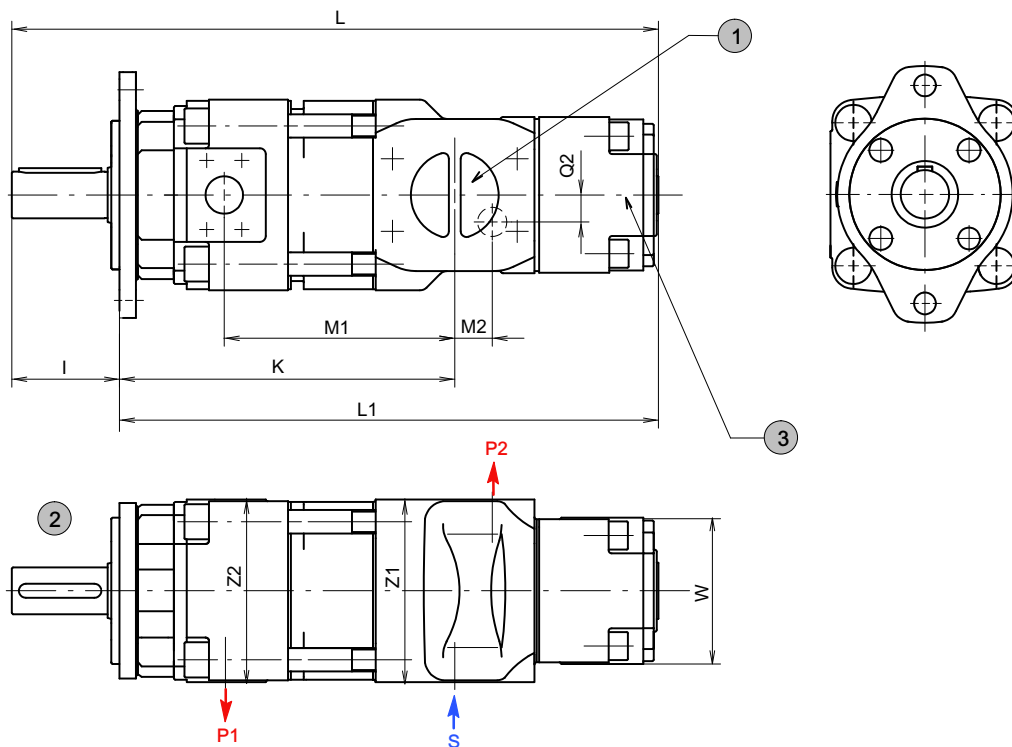

<b>1</b>	S = common suction port
<b>2</b>	shaft and mounting dimensions - see section 4

<b>3</b>	option 83 = depending on operating conditions, a second suction port may be required - see section 2.2.1 QX61=SAE 2"
----------	--

Type	L	L1	K	M1	M2	Q2	I	Z1	Z2	W	S	P1	P2	
QX33/21	14.42	12.46	7.7	5.2	1.2	-	2.0	4.72	4.72	3.15	G1½" 1)	G¾" 1) 2)	G½" 1) 2)	
QX43/21	16.71	14.03	9.1	6.3	1.4	0.6	2.7	4.92	4.92	3.93	SAE 2"	SAE 1"	G¾" 1) 2)	
QX43/31	17.28	14.60			1.3									
QX53/21	19.86	16.24	11.0	7.5	1.7	-	3.6	6.14	6.14	3.15	SAE 2½"	SAE 1¼"	G½" 1) 2)	
QX53/31	20.43	16.81			1.5									0.6
QX53/41	21.92	18.30	11.3	7.8	1.3	0.9	3.6	7.67	7.75	5.35	SAE 3"	SAE 1½"	SAE 1"	
QX63/31	23.20	19.58	13.3	9.2	1.9	0.5								3.93
QX63/41	24.11	20.49			1.5	1.1								5.35
QX63/51	25.55	21.92	13.5	9.4	1.6	1.1	4.6	9.84	9.84	6.49	SAE 3½"	SAE 2"	SAE 1¼"	
QX83/41	29.21	24.60	16.7	11.6	2.0	1.0								5.35
QX83/51	30.25	25.65			1.9	1.2								6.49
QX83/61	31.31	26.71			1.8	1.4	7.99	SAE 4"				SAE 1½"		

1) Threaded port to DIN 3852 Part 2.

2) Pressure port to SAE J 518 can be supplied for pressure ranges 2+3.

## H Double pumps QX.3/.2

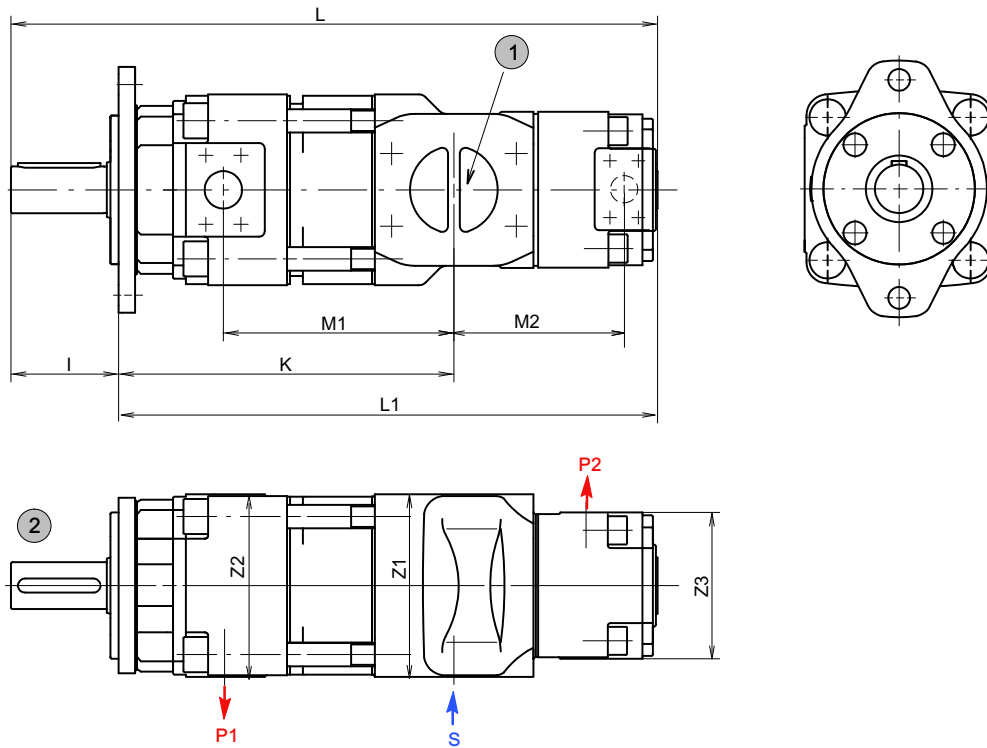

**1** S = common suction port

**2** shaft and mounting dimensions - see section 4

Type	L	L1	K	M1	M2	I	Z1	Z2	Z3	S	P1	P2
QX23/22	11.57	9.80	6.2	4.0	2.6	1.8	3.93		3.93	G1¼" 1)	G½" 1) 2)	G½" 1) 2)
QX33/22	13.74	11.77	7.7	5.2	3.1	2.0	4.72	4.72		G1½" 1)	G¾" 1) 2)	
QX33/32	14.25	12.28			3.4				3.3	2.7	4.92	3.93
QX43/22	16.02	13.34	9.1	6.3	3.6	2.7	4.92	4.72				
QX43/32	16.53	13.85							9.4	6.6	4.4	3.6
QX43/42	17.75	15.07	11.0	7.5	3.6	3.6	6.14	3.93				
QX53/22	19.17	15.55							11.3	7.8	3.9	3.6
QX53/32	19.66	16.04	11.3	7.8	4.6	3.6	6.14	4.92				
QX53/42	20.90	17.28							13.3	9.2	4.4	3.6
QX53/52	21.73	18.11	13.3	9.2	4.8	3.6	7.67	7.75				
QX63/32	22.48	18.85							13.5	9.4	5.4	3.6
QX63/42	23.09	19.46	13.5	9.4	5.9	3.6	7.67	7.75				
QX63/52	24.29	20.66							16.7	11.2	5.6	4.6
QX63/62	25.03	21.41	16.7	11.2	5.9	4.6	9.84	6.14				
QX83/42	28.18	23.58							16.7	11.2	6.4	4.6
QX83/52	28.99	24.39	16.7	11.2	7.0	4.6	9.84	9.84				
QX83/62	29.76	25.15							16.7	11.2	7.0	4.6
QX83/82	31.10	26.49	16.7	11.2	7.0	4.6	9.84	9.84				

1) Threaded port to DIN 3852. Part 2.

2) Pressure port to SAE J 518 can be supplied for pressure ranges 2+3.

I Double pumps QX.3/3

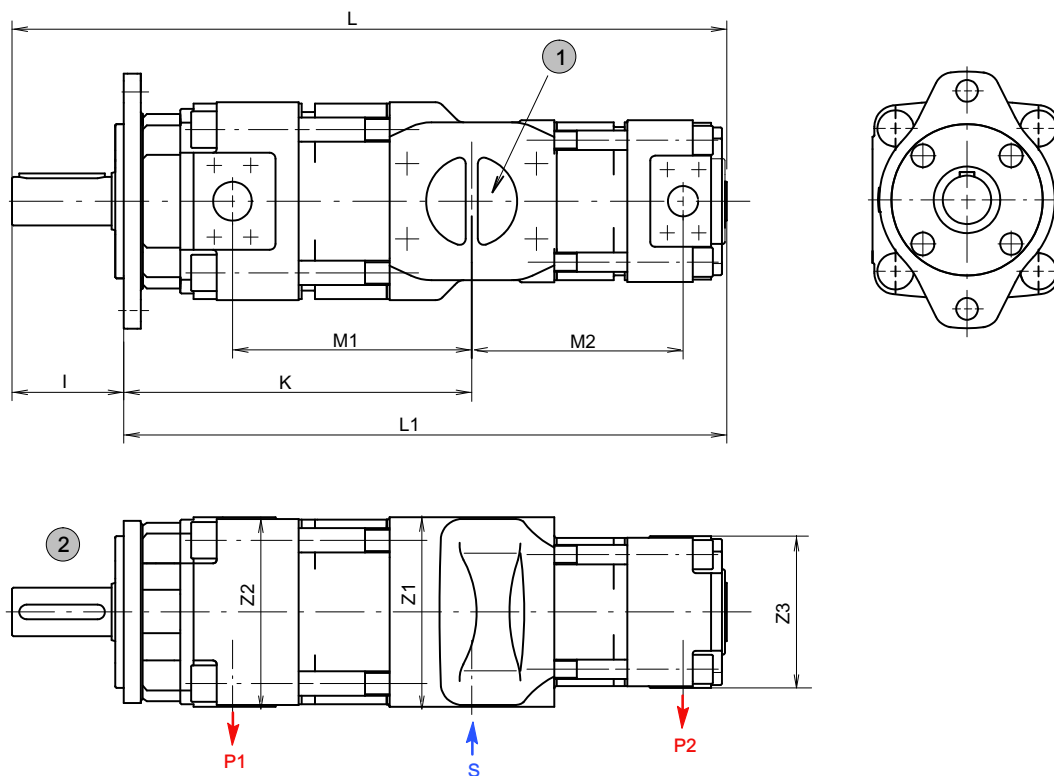

1 S = common suction port

2 shaft and mounting dimensions - see section 4

Type	L	L1	K	M1	M2	I	Z1	Z2	Z3	S	P1	P2
QX23/23	12.93	11.16	6.2	4.0	1.0	1.8	3.93		3.93	G1¼" 1) 2)	G½" 1) 2)	G½" 1) 2)
QX33/23	15.09	13.13	7.7	5.2	4.5	2.0	4.72			4.72	G1½" 1) 2)	G¾" 1) 2)
QX33/33	16.00	14.03			5.2							
QX43/23	17.40	14.72	9.1	6.3	4.7	2.7	4.92		3.93	SAE 2"	SAE 1"	G½" 1) 2)
QX43/33	18.28	15.61			5.4			4.72				G¾" 1)
QX43/43	19.96	17.28			6.6			4.92				SAE 1"
QX53/23	20.55	16.92	11.0	7.5	5.0	3.6	6.14		3.93	SAE 2½"	SAE 1¼"	G½" 1) 2)
QX53/33	21.43	17.81			5.7			4.72				G¾" 1) 2)
QX53/43	23.11	19.48			6.9			4.92				SAE 1"
QX53/53	24.48	20.86			7.8			6.14				SAE 1¼"
QX63/33	24.21	20.59	13.3	9.2	6.2	3.6	7.67	7.75	4.72	SAE 3"	SAE 1½"	G¾" 1) 2)
QX63/43	25.29	21.67			7.0				4.92			SAE 1"
QX63/53	27.04	23.42			8.1				6.14			SAE 1¼"
QX63/63	28.62	25.00	13.5	9.4	9.4	4.6	9.84		7.75	SAE 3½"	SAE 2"	SAE 1½"
QX83/43	30.39	25.78			7.8			4.92				SAE 1"
QX83/53	31.75	27.14	16.7	11.2	8.7	4.6	9.84		6.14	SAE 4"	SAE 2"	SAE 1¼"
QX83/63	33.30	28.70			9.9			7.75				SAE 1½"
QX83/83	35.61	31.00			11.6			9.84				SAE 2"

1) Threaded port to DIN 3852. Part 2.

2) Pressure port to SAE J 518 can be supplied for pressure ranges 2+3.



## 6 Triple pumps

The following table shows the triple-pump combinations that can be supplied (other triple-pumps on request). The individual pumps 1, 2 and 3 must be specified in accordance with the main characteristics shown in section 2.

The largest pump of the combination is situated at the shaft end and is referred to as pump 1. For equal frame sizes, the pump with the larger displacement is situated at the drive side, pumps 2 and 3 have a common suction port.

**IMPORTANT:** Triple pumps with pressure range 4 on request.

### 6.1 Selection table

Frame size of Pump 1						
QX2.	QX3.	QX4.	QX5.	QX5.	QX6.	QX8.
QX21/21/21	QX31/21/21	QX41/21/21	QX51/22/23	QX52/52/31	QX61/31/33	QX81/42/23
QX21/21/22	QX31/21/22	QX41/21/23	QX51/23/23	QX52/52/42	QX61/41/21	QX82/42/43
QX21/21/23	QX31/21/23	QX41/22/22	QX52/23/23	QX52/52/43	QX61/41/42	QX82/51/53
QX21/22/22	QX31/22/22	QX41/23/23	QX53/22/22	QX52/52/52	QX61/42/23	QX83/51/53
QX21/22/23	QX31/22/23	QX42/22/22	QX51/31/33	QX52/52/53	QX61/42/43	QX81/61/61
QX21/23/23	QX31/23/22	QX43/22/22	QX51/33/33	QX52/53/31	QX61/43/43	QX81/62/63
QX22/22/22	QX31/23/23	QX43/23/22	QX51/41/23	QX52/53/53	QX62/41/22	QX81/63/33
QX23/23/23	QX32/22/22	QX43/23/23	QX51/41/42	QX53/53/23	QX62/42/42	QX82/61/61
	QX32/22/23	QX41/31/33	QX51/41/43	QX53/53/33	QX62/43/43	QX82/62/52
	QX32/23/23	QX41/33/22	QX51/42/22		QX63/43/22	QX82/62/62
	QX33/21/22	QX41/33/33	QX51/42/43		QX61/52/53	QX82/63/31
	QX33/21/23	QX42/31/32	QX51/43/21		QX61/53/23	QX83/61/61
	QX33/23/23	QX42/32/32	QX51/43/22		QX61/53/31	QX83/63/61
	QX31/31/21	QX42/33/32	QX51/43/23		QX62/52/32	QX81/81/61
	QX31/31/22	QX43/31/31	QX51/43/43		QX62/52/52	QX81/81/81
	QX31/31/23	QX43/33/33	QX52/42/23		QX62/53/22	QX82/82/52
	QX31/31/31	QX41/41/33	QX52/42/42		QX62/53/23	QX82/82/62
	QX31/31/33	QX41/42/21	QX52/43/22		QX62/53/31	QX82/82/63
	QX31/32/22	QX41/42/23	QX52/43/23		QX62/53/33	QX83/83/53
	QX31/33/33	QX41/42/42	QX52/43/43		QX63/51/51	
	QX32/32/22	QX41/43/21	QX53/41/22		QX63/53/53	
	QX32/32/23	QX41/43/22	QX53/41/23		QX61/61/31	
	QX32/32/32	QX41/43/23	QX53/42/22		QX61/61/33	
	QX32/32/33	QX42/42/22	QX53/42/43		QX61/61/41	
	QX33/33/23	QX42/42/23	QX53/43/23		QX61/61/53	
	QX33/33/33	QX42/42/31	QX51/51/21*		QX61/62/42	
		QX42/42/32	QX51/51/32		QX61/62/63	
		QX42/42/33	QX51/51/33		QX61/63/32	
		QX42/42/42	QX51/52/32		QX61/63/33	
		QX42/42/43	QX51/52/33		QX61/63/41	
		QX43/43/43	QX51/52/42		QX61/63/42	
			QX51/52/43		QX62/62/33	
			QX51/53/22		QX62/62/43	
			QX51/53/23		QX62/62/53	
			QX51/53/31		QX62/62/62	
			QX51/53/33		QX62/62/63	
			QX51/53/41		QX62/63/63	
			QX51/53/43		QX63/63/32	
			QX51/53/52		QX63/63/43	
			QX52/52/23		QX63/63/53	
575	1151	2301	4603	4603	9294	18587

Maximum permissible drive shaft torque [lb-in]

\* this pump is used as the ordering example in section 6.2



## 7 Low-flow capability pump in combination with other QX-single pumps

### 7.1 Dimensions [inch]

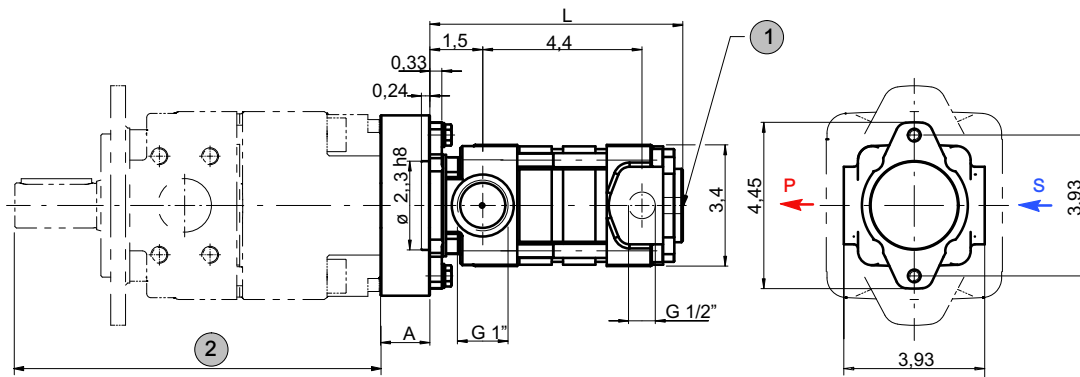

QX pump	A
QX21-...	1.32
QX22-...	1.04
QX31-...	1.34
QX32-...	1.02
QX41-...	1.38
QX42-...	1.10
QX52-...	1.02

1	external drain port G $\frac{1}{4}$ "
2	dimensions see section 4

3	dimension A depends on the driving QX pump model (2)
---	--



## 8 Fluid cleanliness

QX pumps require fluid with a minimum cleanliness level of ISO 4406 code 20/18/15.

We recommend the use of fluids that contain anti-wear additives for mixed-friction operating conditions. Fluids without appropriate additives can reduce the service life of pumps and motors. The user is responsible for maintaining, and regularly checking, the fluid quality. Bucher Hydraulics recommends a load capacity of  $\geq 30 \text{ N/mm}^2$  to Brügger DIN 51347-2.

## 9 Operational reliability

To guarantee the reliable operation and a long service life of the pump, a maintenance schedule must be prepared for the power unit, machine or system. The maintenance schedule must make sure that the provided or permissible operating conditions of the pump are adhered to over the period of use.

In particular, compliance with the following operating parameters must be ensured:

- required oil cleanliness
- operating temperature range
- fluid level

Moreover, the pump and the system must be inspected at regular intervals for changes in the following parameters:

- Vibration
- Noise
- Differential temperature of pump – fluid in the tank
- Foaming in the tank
- Leak tightness

Changes in these parameters indicate wear of components (e.g. drive motor, coupling, pump, etc.). The cause must be immediately pinpointed and eliminated.

To provide high operational reliability of the pump in the machine or system, we recommend continuous, automatic checks of the above parameters and an automatic shut-down in the case of changes that exceed the usual fluctuations within the provided operating range.



Make sure that the plastic components of the coupling will be exchanged regularly (no later than 5 years). The manufacturer's instructions must be given priority.

## 10 Note

This catalogue is intended for users with specialist knowledge. The user must check the suitability of the equipment described herein in order to ensure that all of the conditions necessary for the safety and proper functioning of the system are fulfilled. If you have any doubts or questions concerning the use of these pumps, please consult Bucher Hydraulics GmbH.

## 11 Accessories

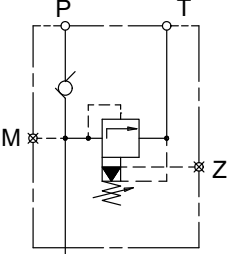
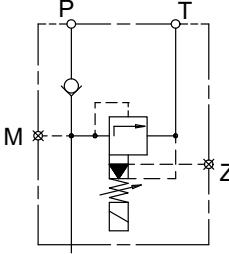
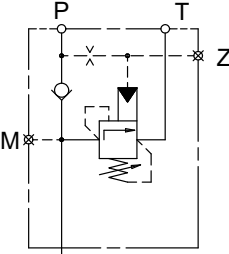
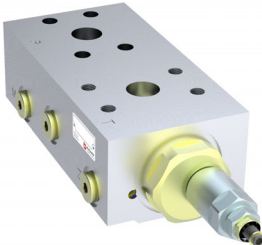
### 11.1 Bolt-on valves - SAE J518 code 61 / ISO 6162-1 pattern

Pressure relief A $\frac{S}{G}$ DF	Pressure relief solenoid control A $\frac{S}{G}$ DA	Accumulator charging valve AGSF
		
		
<p>Technical data sheet 100-P-000123</p>	<p>Technical data sheet 100-P-000119</p>	<p>Technical data sheet 100-P-0000124</p>

#### 11.1.1 Examples for Bolt-on valves, mounted on QX Internal Gear Pumps

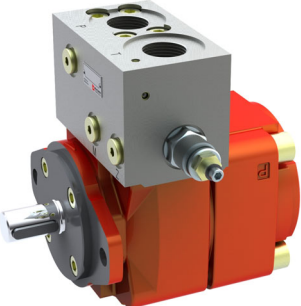
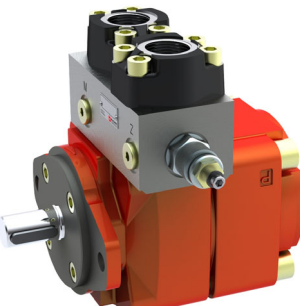
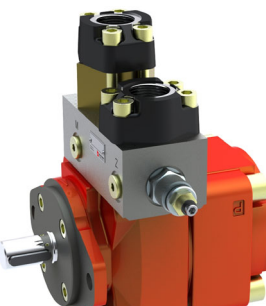
Bolt-on valve with threaded ports AGDF	Bolt-on valves with pipe flanges SAE <sup>1)</sup> ASDF+RF	Bolt-on valve with pipe flanges SAE + RVSAE <sup>2)</sup> ASDF+RF+RVSAE+DPSAE+ZPSAE
		

1) Pipe flange see section 12.2 and 12.3..

2) Please ask Bucher Hydraulics GmbH for check valves.

**IMPORTANT:** For detailed informations on bolt-on valves see [www.bucherhydraulics.com](http://www.bucherhydraulics.com)

## 11.2 Pipe flange - high pressure type

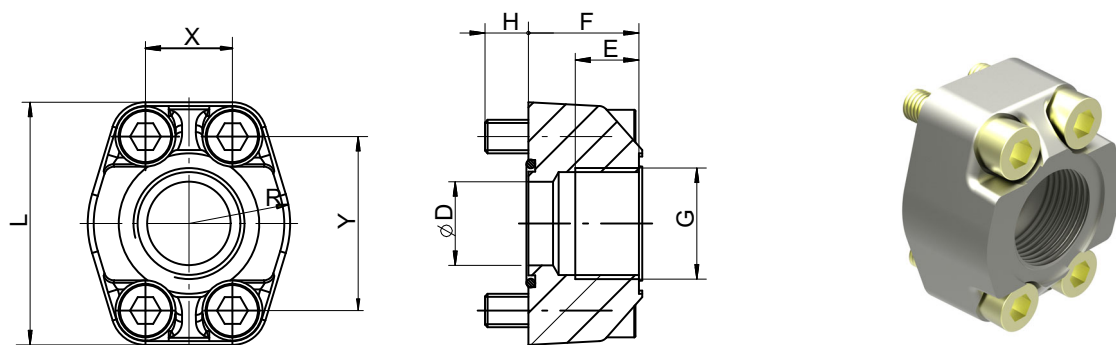

- Max. operating pressure 420 bar (6090 PSI)

- Flange size SAE J518 code 61 / ISO 6162-1

Material: ST37 / for FKM (Viton) seals contact Bucher Hydraulics GmbH.

Threaded pipe flanges are spot-faced for DIN 2353 pipe fittings.

Ordering-number	Ordering code	Size	DØ	E	F	H	L	R	X	Y	Viton seal 90 Shore 'A'	Retaining screws DIN912-12.9	Torque lb-in
037000	RF 01-R08	G½"	0.5	0.6	1.1	0.5	2.1	0.9	0.69	1.49	0.79x0.10	M8 x 30	266
037010	RF 02-R10	G¾"	0.8	0.7	1.2	0.47	2.6	1.0	0.87	1.87	1.05x0.10	M10 x 30	531
037020	RF 03-R11	G1"	1.0	0.8	1.3	0.5	2.7	1.1	1.03	2.06	1.29x0.10	M10 x 35	531
037030	RF 04-R12	G1¼"	1.3	1.0	1.5	0.6	3.1	1.4	1.19	2.31	1.61x0.14	M10 x 40	531
037040	RF 05-R13	G1½"	1.5	0.9	1.6	0.7	3.7	1.6	1.41	2.76	1.73x0.14	M12 x 45	1062
037050	RF 06-R14	G2"	1.9	1.1	1.8	0.8	4.0	1.9	1.69	3.06	2.36x0.14	M12 x 50	1062
055470 *	RF 07-R16	G2½"	2.5	1.2	1.9	0.7	4.5	2.2	1.99	3.50	2.86x0.14	M12 x 45	1062

\* at RF07 only to 210 bar (3045 PSI) be allowed

### 11.3 Pipe flange - low pressure type

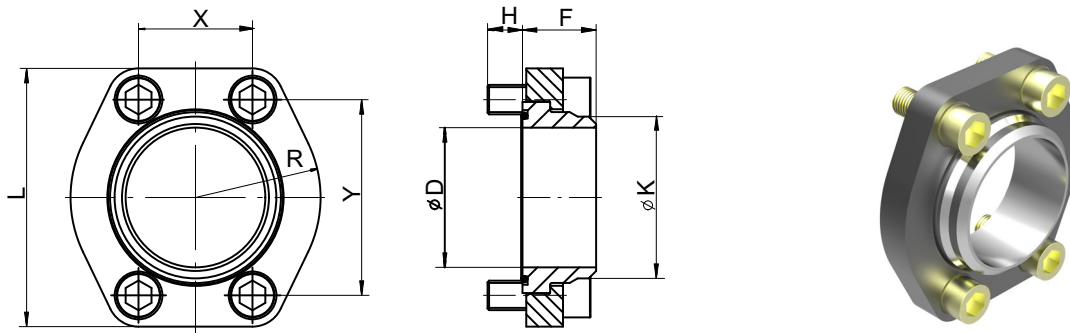

- Max. operating pressure 16 bar (232 PSI)
- Flange size SAEJ518 code 61 / ISO 6162-1.

Material: HST37 / for FKM (Viton) seals contact Bucher Hydraulics GmbH.

Ordering number	Ordering code	SAE flange Size	D	K	F	H	L	R	X	Y	Viton seal 90 Shore 'A'	Retaining screws DIN 912-8.8	Torque lb-in	pipe <sup>1)</sup> O/di-a.approx.
062450	RN 07-S	2½"	2.5	2.9	1.3	0.6	4.7	2.5	2.0	3.5	2.73 x 0.14	M12 x 30	620	2.95
063880	RN 08-S	3"	3.0	3.5			5.53	2.7	2.4	4.19	3.36 x 0.14	M16 x 40	1593	3.46
063890	RN 09-S	3½"	3.5	3.9	1.6	0.7	6.23	2.9	2.8	4.74	3.86 x 0.14	M16 x 40	1593	3.93
063900	RN 10-S	4"	4.1	4.5			6.6	3.1	3.1	5.1	4.36 x 0.14	M16 x 40	1593	4.53

1) We recommend the use of seamless precision steel tube to DIN 2391 with wallthick. max 0.24 in.