

QXP Internal Gear Pump

For pumping special-purpose fluids such as isocyanates, polyols and additives

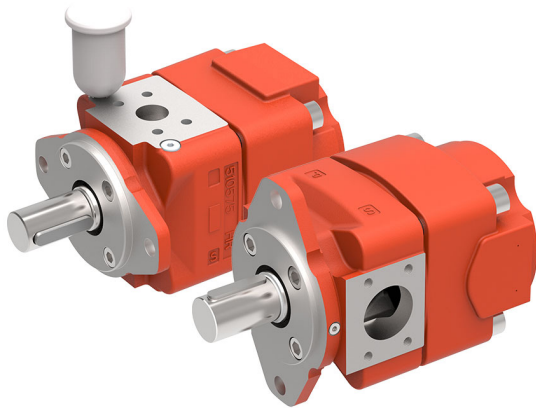

- For use with a wide range of special-purpose fluids
- Operation at high and low viscosity
- Special sealing system to prevent air ingress
- Heavy-duty design and long service life
- Maximum metering accuracy thanks to low pulsation
- For use with variable-speed drives

1 Description

1.1 General

The QXP internal gear pump has been purposely designed for pumping unusual, special-purpose fluids. Accordingly, the QXP can handle viscosities ranging from very low to very high and, due to its special sealing materials, is also suitable for pumping chemically demanding fluids. Thanks to the non-compensated internal gear design and Bucher's special gear profile, the QXP produces extremely low pulsation levels. This provides very smooth and quiet running and ensures high metering accuracy, the latter being a key

requirement in the production of polyurethane, for example. In its standard version, the QXP has all the features of a QX pump but also includes particular adaptations which enable the pump to handle special-purpose fluids. With special features for particular applications, QXP pumps can also be used to pump fluids such as isocyanates, polyols, epoxy resins and additives. Thanks to their rugged construction, the pumps also have a long service life.

1.2 Application Example

All process-engineering applications for pumping special-purpose fluids. Examples are high- and low-pressure systems in polyurethane production.

2 Technical data

General characteristics	Unit	Description, Value
Installation attitude		unrestricted
Mounting method (standard)		oval 2-hole flange to ISO 3019/1 (SAE): QXP 3-6 oval 2-hole flange to ISO 3019/2 (metric) QXP 2+8
Direction of rotation		CW or CCW (but not reversible)
Pump drive method		flexible shaft coupling magnetic coupling (contact Bucher Hydraulics)
Volumetric efficiency η_v		approx. 95%
Pumpable media		Isocyanates, polyols, epoxy-resin components and additives For other unusual or special-purpose fluids, please inquire.

General characteristics	Unit	Description, Value
Viscosity range	mm ² /s (cSt)	10 ... 300 (for values from 3 to 20'000 mm ² /s, contact Bucher Hydraulics)
Inlet pressure maximum minimum	bar	4,0 absolute (with PTFE- shaft seal only) 0.5 ... 0.95 absolute (depending on frame size, speed and viscosity)
Start-up against pressure	bar	maximum 20 (higher values on request)
Seal material Dichtungswerkstoff		FPM (Viton) = standard, PTFE shaft seal - please inquire FPM (Viton) = Standard, PTFE- Dichtung auf Anfrage

IMPORTANT: The following main characteristics are valid for fluids with 40 mm²/s.

2.1 Main characteristics for pressure range 1

Effective displacement ⁴⁾ [cm ³ /rev]	Max. Speed [rpm]	Type	Continuous pressure ¹⁾ [bar]	Torque ²⁾ [Nm]	Power requirement at rpm 1450 ³⁾ [kW]
10,3 12,6 15,9	1800	QXP21-010 QXP21-012 QXP21-016	100	26 25 25	2,7 3,3 3,9
20,0 25,2 31,1	1800	QXP31-020 QXP31-025 QXP31-032	100	51 50 50	5,2 6,5 7,5
40,6 50,2 64,5	1800	QXP41-040 QXP41-050 QXP41-063	100	104 100 103	10,5 13,0 15,6
78,3 100,6 126,7	1500	QXP51-080 QXP51-100 QXP51-125	100	200 201 203	20,2 25,9 30,8
159,7 201,1 248,4	1500	QXP61-160 QXP61-200 QXP61-250	100	409 402 397	41,1 51,7 63,9
323,9 400,1 495,4	1500	QXP81-315 QXP81-400 QXP81-500	100	830 801 793	83,3 102,9 127,4

1) Maximum pressure values apply for 20 - 100 mm²/s.

2) Theoretical value at max. permitted continuous pressure.

3) Theoretical value at max. Permitted continuous pressure calculated at 40 mm²/s.

4) Due to manufacturing tolerances, there may be slight variations in the displacement.

2.2 Main characteristics for pressure range 2

Effective displacement ⁴⁾ [cm ³ /rev]	Max. Speed [rpm]	Type	Continuous pressure. ¹⁾ [bar]	Torque ²⁾ [Nm]	Power requirement at rpm 1450 ³⁾ [kW]
3,2 4,2 5,1 6,3 7,9	1800	QXP22-003 QXP22-004 QXP22-005 QXP22-006 QXP22-008	210	10 13 17 21 27	1,9 2,3 2,6 3,2 4,0
10,0 12,6 15,6	1800	QXP32-010 QXP32-012 QXP32-016	210	34 42 52	5,1 6,4 7,9
20,3 25,1 32,3	1800	QXP42-020 QXP42-025 QXP42-032	210	68 84 108	10,4 12,7 16,5
39,1 50,3 63,4	1500	QXP52-040 QXP52-050 QXP52-063	210	132 170 213	19,9 25,7 32,3
79,8 100,5 124,2	1500	QXP62-080 QXP62-100 QXP62-125	210	268 338 417	40,7 51,2 63,4
161,9 200,0 247,7	1500	QXP82-160 QXP82-200 QXP82-250	210	544 672 833	82,7 102,1 126,5

2.3 Main characteristics for pressure range 3

Effective displacement ⁴⁾ [cm ³ /rev]	Max. Speed [rpm]	Type	Continuous pressure. ¹⁾ [bar]	Torque ²⁾ [Nm]	Power requirement at rpm 1450 ³⁾ [kW]
5,1 6,3 7,9	1800	QXP23-005 QXP23-006 QXP23-008	250	26 32 41	3,4 4,2 5,4
10,0 12,6 15,6	1800	QXP33-010 QXP33-012 QXP33-016	250	51 64 80	6,5 8,8 10,2
20,3 25,1 32,3	1800	QXP43-020 QXP43-025 QXP43-032	250	104 128 165	13,2 16,5 21,0
39,1 50,3 63,4	1500	QXP53-040 QXP53-050 QXP53-063	250	200 258 321	25,5 32,5 40,8
79,8 100,5 124,2	1500	QXP63-080 QXP63-100 QXP63-125	250	409 514 636	51,9 65,5 81,4
161,9 200,0 247,7	1500	QXP83-160 QXP83-200 QXP83-250	250	830 1025 1270	105,0 131,2 161,7

1) Maximum pressure values apply for 20 - 100 mm²/s.

2) Theoretical value at max. permitted continuous pressure.

3) Theoretical value at max. permitted continuous pressure calculated at 40 mm²/s.

4) Due to manufacturing tolerances, there may be slight variations in the displacement.

3 Dimensions

Frame size		2			3			4			5			6			8		
Pressure range		1	2	3	1	2	3	1	2	3	1	2	3	1	2	3	1	2	3
Pressure ports to SAE J518 ¹⁾	P	G1/2" ³⁾ ⁴⁾ thread			G3/4" ³⁾ ⁴⁾ thread			1"			1 1/4"			1 1/2"			2"		
Input port: to standard SAE J518 ¹⁾	S	G1" ³⁾ thread			G1 1/4" ³⁾ thread			1 1/2"			2"			2 1/2"			3"		
Mounting: oval 2-hole flange to ISO 3019/1 (SAE) ISO3019/2 (metr.)	A	118			132			170			212			267			330		
	B (SAE)	-			106			146			181			229			-		
	B (Metr.)	100			109			140			180			224			280		
	C	9			11			14			18			22			26		
	N (SAE)	-			82,55 - 0,05			101,6 - 0,05			127 - 0,05			152,4 - 0,05			-		
	N (Metr.)	63 h8			80 h8			100 h8			125 h8			160 h8			200 h8		
	O	8,5			8,5			10,5			12,5			16,5			20		
V	6			6			7			7			7			9			
4-hole flange ISO 3019/2	X (Metr.)	9			9			12			14			18			22		
	Y (Metr.)	85			103			125			160			200			250		
Shaft end parallel to ISO/R775 ²⁾	D	20 j6			25 j6			32 j6			40 j6			50 j6			63 j6		
	E	36			42			58			82			82			105		
	F	6			8			10			12			14			18		
	G	22,5			28			35			43			53,5			67		
	I	45			50			68			92			92			117		
Housing	K	37,5			44			52,5			60,5			74			90		
	L	136	117 ⁵⁾	153	164	144	189	202	176	232	242	210	280	288	248	338	361	331	426
	M	-	55 ⁵⁾	90	-	69,5	114	-	87	143	-	102	172	-	119	209	-	151	266
	T	85			107			133			177			214	220	220	273	275	275
	Z	50			60			62,5			78			97,5			125		
Weight	kg	5	5	6,5	10	9,6	12,2	19,6	17,2	22	33	31	41	64	57	78	130	120	160

1) For SAE J518 Code 61 or ISO 6162-1 pipe flange dimensions (see section 6).

2) For other shaft ends contact Bucher Hydraulics.

3) Threaded port to DIN 3852, Part 2.

4) Pressure port to SAE J 518 code 61 or ISO 6162-1 can be supplied for pressure ranges 2+3.

5) For QXP22-003 and QXP22-004 : L = 113 ; M = 51.

3.1 Pressure range 1

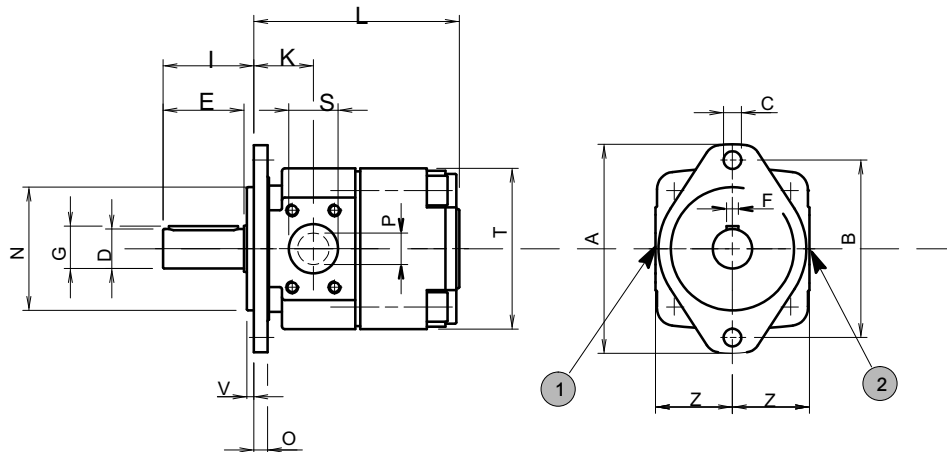

3.2 Pressure range 2

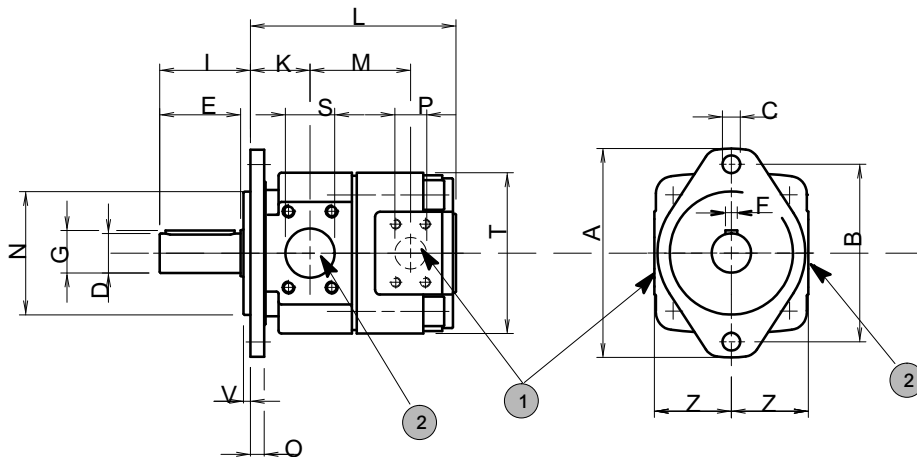

3.3 Pressure range 3

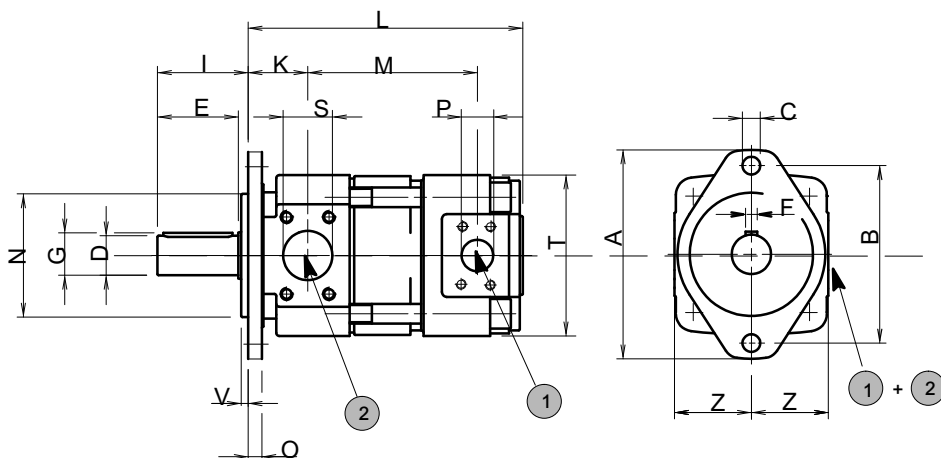

1	Pressure port P
2	Suction port S

6 Accessories

6.1 Pipe flange - high pressure type for up to 420 bar

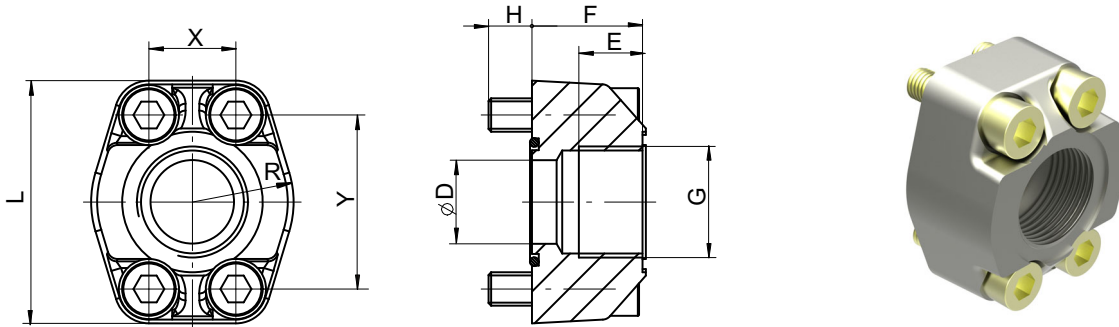

- Max. operating pressure 420 bar
- Possible for size 4 - 6
- Flange size SAE J518 code 61 / ISO 6162-1

- Threaded pipe flanges are spot-faced for DIN 2353 pipe fittings.
- Material: ST37 / for FPM (viton) seals contact Bucher Hydraulics.

Ordering-number	Ordering code	Size	DØ	E	F	H	L	R	X	Y	O-ring 90 Shore 'A'	Retaining screws DIN912-12.9 / Torque Nm	
037000	RF 01-R08	G 1/2"	12,5	16	27	13	54	23	17,5	38	20,24x2,62	M 8x30	30
037010	RF 02-R10	G 3/4"	20	18	30	12	65	26	22,2	47,6	26,65x2,62	M10x30	60
037020	RF 03-R11	G 1"	25	20	34	13	70	29	26,2	52,4	32,99x2,62	M10x35	60
037030	RF 04-R12	G 1 1/4"	32	22	38	14	80	36	30,2	58,6	40,86x3,53	M10x40	60
037040	RF 05-R13	G 1 1/2"	38	24	41	19	94	41	35,7	70	44,04x3,53	M12x45	120
037050	RF 06-R14	G 2"	50	26	45	20	102	48	42,9	77,8	59,92x3,53	M12x50	120
055470*	RF 07-R16	G 2 1/2" *	63	30	50	18	114	57	50,8	89	72,62x3,53	M12x45	120

* RF07 to 210 bar only!

6.2 Low pressure type for up to 16 bar

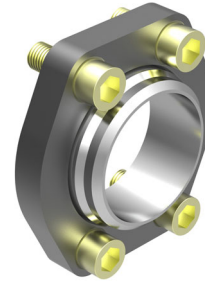
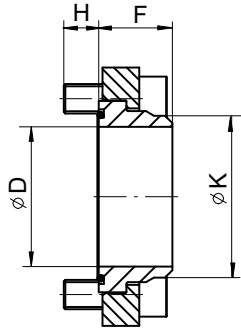
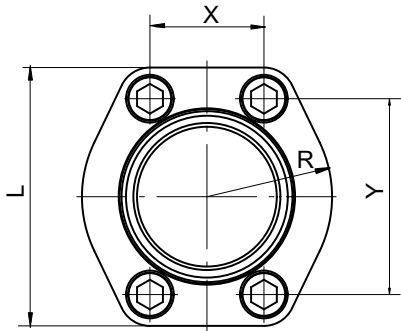

- Max. operating pressure 16 bar
- Possible for size 6
- Flange size SAE J518 code 61 / ISO 6162-1

- Material: ST37 / or FPM (viton) seals contact Bucher Hydraulics.

Ordering number	Ordering code	SAE flange Size	D	K	F	H	L	R	X	Y	O-ring 90 Shore 'A'	Retaining screws DIN 912-8.8 Torque Nm	pipe 1) O/dia. approx.
062450	RF 07-S	2 1/2"	63	75	35	14	120	57	51	89	69,44x3,53	M12 x 30 70	75
063880	RN 08-S	3"	76	88			140,5	68	62	106,5	85,32x3,53	M16 x 40 180	88
063890	RN 09-S	3 1/2"	89	100	40	19	158,5	73	70	120,3	98,02x3,53	M16 x 40 180	100
063900	RN 10-S	4"	103	115			168	79	78	130	110,72x3,53	M16 x 40 180	115

1) We recommend the use of seamless precision steel tube to DIN 2391 with wallthick. max 6 mm

info.kl@bucherhydraulics.com

www.bucherhydraulics.com

© 2021 by Bucher Hydraulics GmbH, D-79771 Klettgau

All rights reserved.

Data is provided for the purpose of product description only, and must not be construed as warranted characteristics in the legal sense. The information does not relieve users from the duty of conducting their own evaluations and tests. Because the products are subject to continual improvement, we reserve the right to amend the product specifications contained in this catalogue.

Classification: 410.100.