

## Hydraulic Units UP50

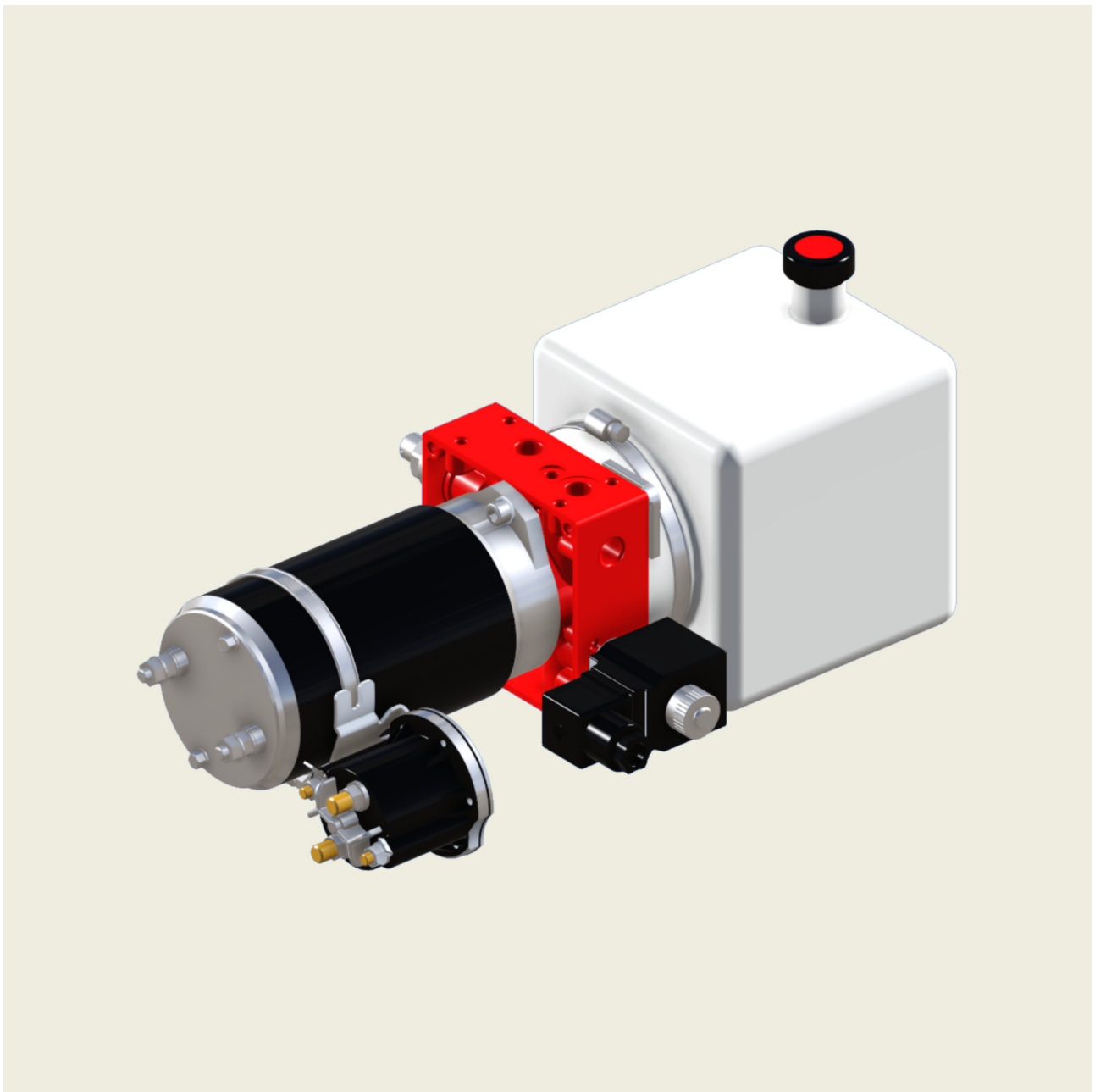

1800-OILSOL  
1800-645765

<https://oilsolutions.com.au/>

[sales@oilsolutions.com.au](mailto:sales@oilsolutions.com.au)

Reference: 200-P-991186-EN-09

### Contents

Page

1	Power pack housing .....	7
1.1	Technical information .....	7
1.2	Housing UP50 K03-K34 (P and T connections) Machined for flanged manifolds .....	8
1.3	Housing UP50: K17-K04-K41-K42-K46 (threaded ports) .....	10
1.4	Housing UP50K50-K52 (Reversible circuit) with threaded ports .....	13
1.5	Preassembled housing .....	14
2	Gear pumps .....	15
2.1	Technical information .....	15
2.2	Gear pumps AP05/** S409 - Counterclockwise rotation .....	17
2.3	Gear pumps APR05/** -339F - Reversible .....	18
3	Tanks .....	19
3.1	Plastic tanks .....	19
3.2	Fitment and fixing positions .....	21
3.3	Steel collar .....	23
4	Suction/return assembly kits .....	25
4.1	Suction assembly kits for plastic tanks horizontal positions for standard AP05/***- S409 Ø14 .....	25
4.2	Suction assembly kits for plastic tanks vertical positions for standard AP05/***-S409 Ø14	25
4.3	Suction assembly kits - Reversible version .....	25
5	Electric motors .....	26
5.1	D.C. Electric motors .....	26
5.2	A.C. Motors .....	40
6	Drives .....	43
6.1	Introduction .....	43
6.2	Materials .....	43
6.3	Drives for D.C. motors .....	44
6.4	Drives for A.C. motors .....	44
6.5	Drive E61 .....	45
6.6	Drive E65 .....	45
6.7	Drive E66 .....	45
6.8	Drive E30 .....	46
6.9	Drive E31 .....	46
6.10	Drive E33 .....	46
7	Cartridge valves .....	47
7.1	Introduction .....	47

7.2	Pressure relief valves .....	50
7.3	Solenoid operated directional valves .....	51
7.4	Mechanical valves .....	59
7.5	Manual lowering valve .....	60
7.6	Emergency hand pump: PM817/1.5 .....	66
7.7	Valve cavity plugs .....	67
<hr/>		
<b>8</b>	<b>Manifolds .....</b>	<b>68</b>
8.1	Technical information .....	68
8.2	Manifold for parallel circuit .....	68
8.3	Manifold for series circuit .....	70
8.4	Solenoid valves dedicated to Manifolds .....	72
<hr/>		
<b>9</b>	<b>Components .....</b>	<b>73</b>
9.1	Steel plate bracket pressed for UP housing SL01 .....	73
9.2	Protective cover PP01 for D.C. motors .....	73
9.3	Microswitch .....	73
<hr/>		
<b>10</b>	<b>Operation and maintenance .....</b>	<b>74</b>
10.1	Oil .....	74
10.2	Starting .....	74
10.3	Maintenance .....	74
10.4	Dealing with possible trouble .....	74
10.5	Example of hydraulic power pack ordering code .....	76

## General specifications

Experience acquired in designing mini power packs, and a research effort aimed constantly at satisfying the technical specifications of our customers: these assets have provided the principal resource for development of the UP50 power packs:

- maximum flexibility, allowing the assembly of a great number of different circuits from just 9 basic versions;
- economy of the manufactured product, gained by adopting innovative technologies and by standardizing valve cavities with those of the major hydraulic components manufacturers;
- the assurance of constant quality, thanks to comprehensive control on materials and production cycles;
- compact dimensions achieved through detailed analysis of the geometries involved, and the components used.

Illustrated are some of the various typical applications for UP50 hydraulic power packs.

Power packs are widely utilized in the field of industrial materials handling machines. Lift trucks is a good example, where the compactness of the unit is a particular advantage in view of the limited space available.

The need for fluid power in mobile machines means that power packs can be exploited in the widest variety of applications: lift platforms, and equipment for handling high and bulky loads in general.

Given the facility of integrating power packs with valve blocks designed and constructed to selected functional and dimensional specifications, special circuits can be customized for automation of the most complex machines.

There are also countless applications for industrial machines and stationary equipment in general where the attributes of the power pack are instrumental in simplifying the hydraulic system, bringing significant saving on installation and running cost.

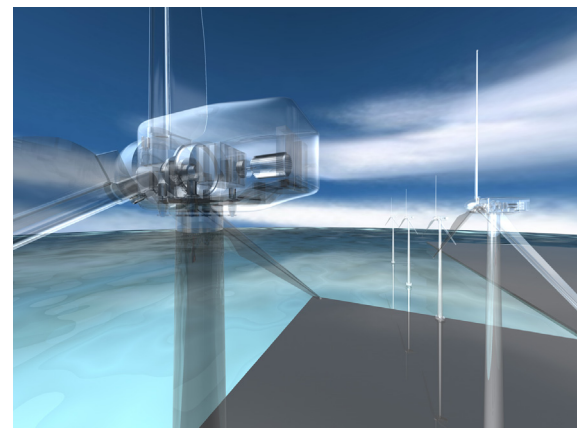
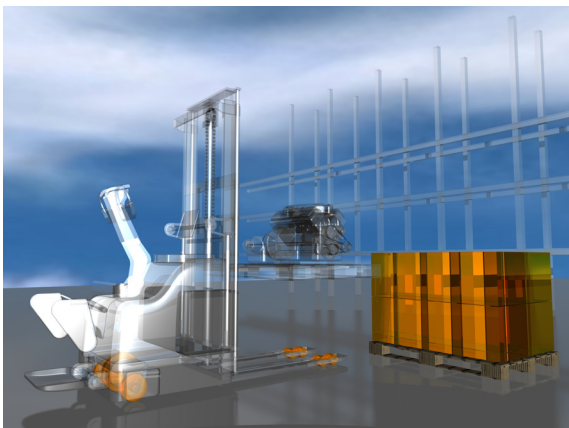



## WARNING!

Bucher Hydraulics is not responsible for misuse or mis-application of product. Pressure values, type and number of cycles have to be considered before choosing the type of product. For any question about applications, please contact Bucher Hydraulics.

All the installation and maintenance operations of partially completed machinery must be made by technically competent personnel.

The hydraulic power units due to its construction does not perform the function of the safety component.

So the user must insert safety components into the machine to protect against the possibility of breakage during operation.

The hydraulic power units can not function independently and are designed to be integrated into hydraulic systems.

Fluids should be contained and disposed of properly.

Prior to performing any maintenance make sure the equipment is turned off and that any stored energy, for example pressure, is released. Also, extended equipment or cylinders should be lowered and mechanically locked as required.

During the handling of the hydraulics power units, do not lift the unit by the tank or valves mounted on it (see the figure 1, the arrows indicate the points to lift). Always wear appropriate safety gloves and footwear.

Always wear eyes protection and protective clothing when working on and around hydraulic systems.

Remove jewellery and objects that might conduct electricity while working on power units.

Hydraulic fluid does pose a fire hazard, can cause burning or skin irritation if not properly handled.

Fluid under pressure can pierce the skin and enter the bloodstream causing death or serious injury.

Devices being operated by the hydraulic system should be immobilized so they cannot move and cause injury while being inspected or repaired. Disconnect from electrical source.

Further information are available in the dedicated documentation according to the Machinery Directive 2006/42/EC

The above warnings are to be adhered to in order to reduce the risks resulting from the normal usage of the hydraulic power units for the safety and health of the users.

The product have purchased is guaranteed for a period according to existing regulations.

The warrant you will be void if the product has been installed or used in a manner not in accordance with our instructions, or if it was tampered with, modified, subjected to usage outside those prescribed.

Fig. 1

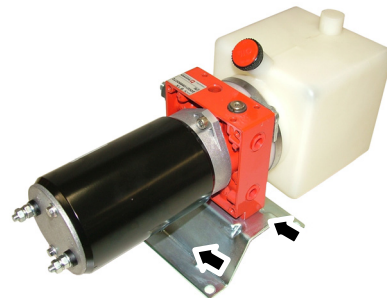

### Directives and standards

- PED (97/23/EC)

The pressure relief valve assembled into the power pack can not to be considered and/or confused with the safety valve when the PED Directive is applied to the hydraulic system.

- Atex:

The equipment and protective systems of these catalogue ARE NOT intended for use in potentially explosive atmospheres that is to say where there is an explosive atmosphere. Ref: Directive 99/92/EC and Directive 2014/34/EU.

- ISO 9001:2015 / ISO 14001:2015

Bucher Hydraulics S.p.A. is certified for research, development and production of directional control valves, power units, gear pumps and motors, electro pumps, cartridge valves and integrated operating blocks for hydraulic applications.

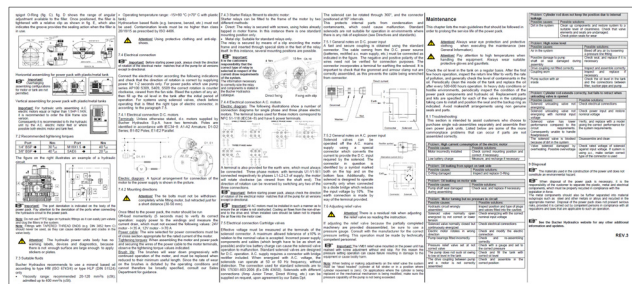
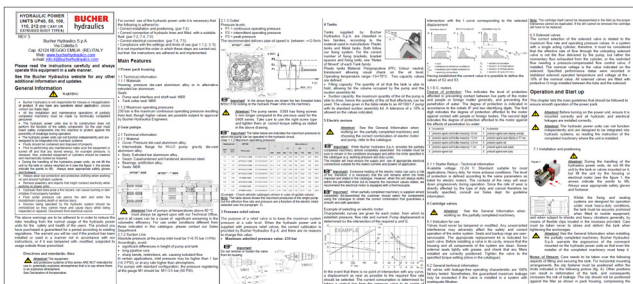

## Sub-assembly index

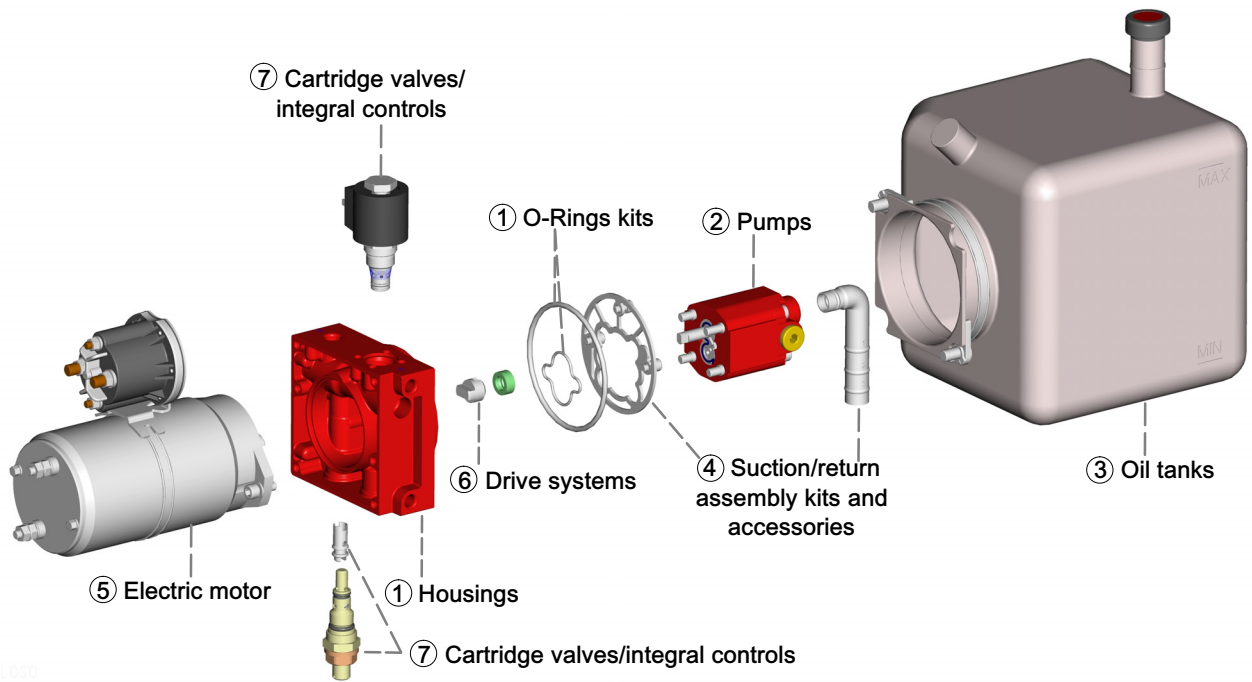

### Sub-assemblies making up UP50 power pack

This page serves both as a guide to the contents of the catalogue and as an order form.

Simply fill in the individual sections with the designation codes for the options selected, and send direct to the Bucher Hydraulics S.p.A. Sales Centres.

1	Type of housing	Vers.											
2	Pump	Hi-Lo	Series										
3	Tank	Fitting	Pos.										
4	Suction assembly kit	Tank fixing kit	Fill in this section only when ordering single sub-assemblies. Leave blank when ordering complete power packs.										
5	Electric motor	Pos.	Relay	Pos.									
6	Drive												
7	Cavity a	Cavity b	Cavity c										
	Cavity d	Cavity e	Cavity f										
	Cavity g	Hand lever	Lever stick	Volt									
8	Sequence	Manifolds	Valves for manifolds	Qty.	Volt								
9	El. n.	Sectional valve housing	Circuit	Posit.	Lever	Hand Lever	Valves for sec. valve						

# 1 Power pack housing

## 1.1 Technical information

### 1.1.1 Materials

Housing: pressure diecast aluminium alloy.  
Seals: Buna N

### 1.1.2 Versions

The design has been developed in such a way that one basic pattern can be exploited to obtain different casting versions, designated:

K03 - K17 - K34- K04 - K41- K42 - K46 - K50 - K52.

### 1.1.3 Maximum operating pressures

230 bar is the maximum continuous operating pressure resulting from test, though higher values are possible subject to approval by Bucher Hydraulics Engineers Dpt.

### 1.1.4 Pumps

The housing versions are intended for use with:  
Single pump AP05 S.409-AP05 S.409F CCW rotation.  
Single pump AP05 339 reversible rotation

### 1.1.5 Valves cavities

Standard cavity "b" will allow 3/4-16 UNF cartridge valves manufactured by Bucher Hydraulics S.p.A., which are interchangeable with similar components made by major European and US manufacturers.

The only exception is the pressure relief and check valves relised according Bucher Hydraulics standard.

A variety of hydraulic circuits can be obtained with the same housing. To facilitate the correct composition of the desired hydraulic circuit, the position of each cavity is identified by a letter. The combination letter/cavity position remain unchanged for all the various UP50 housings.

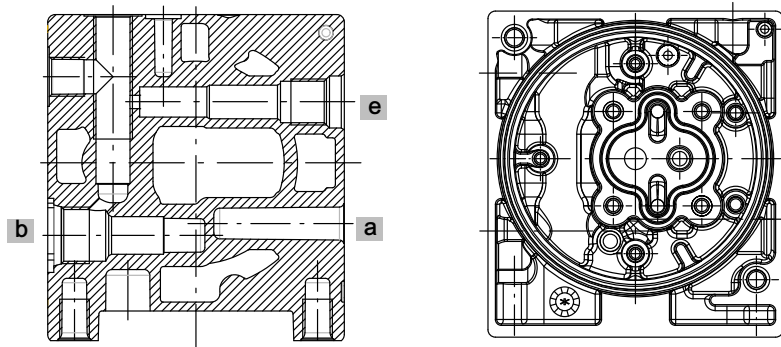

### 1.1.6 Non-standard symbols used in the text

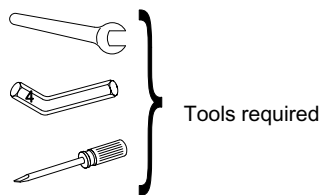

### 1.1.7 Recommended tightening torques

Port .....	Nm	
Standard: 1/4" BSP .....	30 <sup>+7</sup> / <sub>-6</sub>	
Note: other threads on demand		

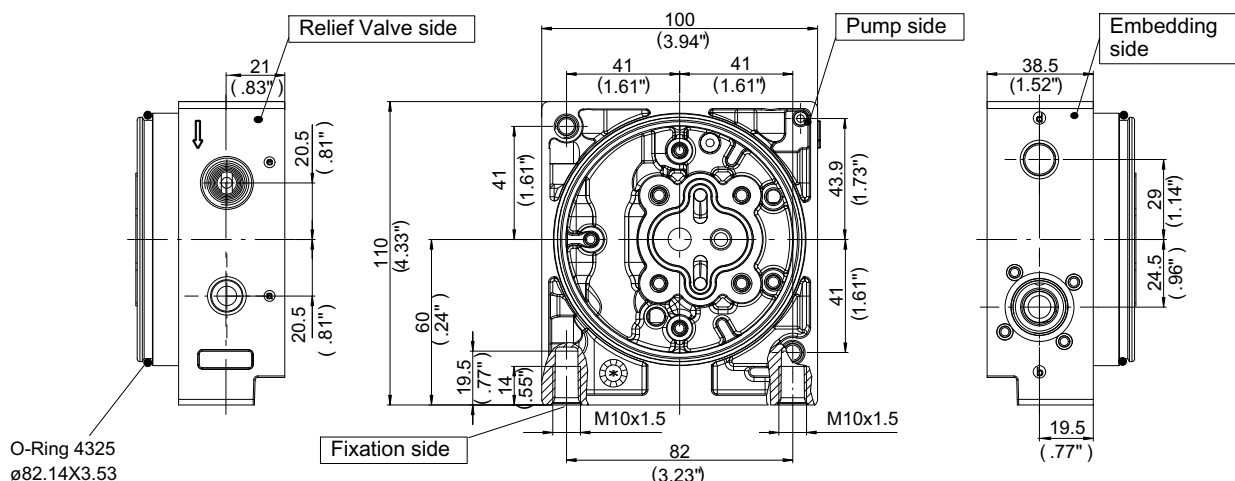

## 1.2 Housing UP50 K03-K34 (P and T connections) Machined for flanged manifolds

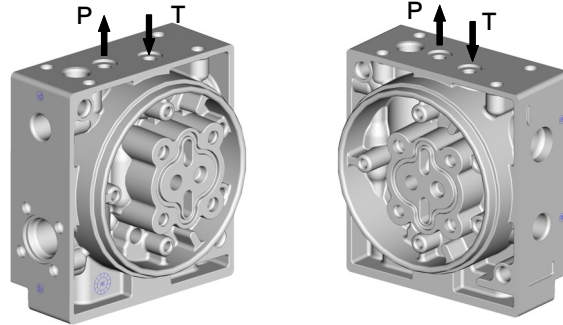

### 1.2.1 K03 - Interface for external manifold

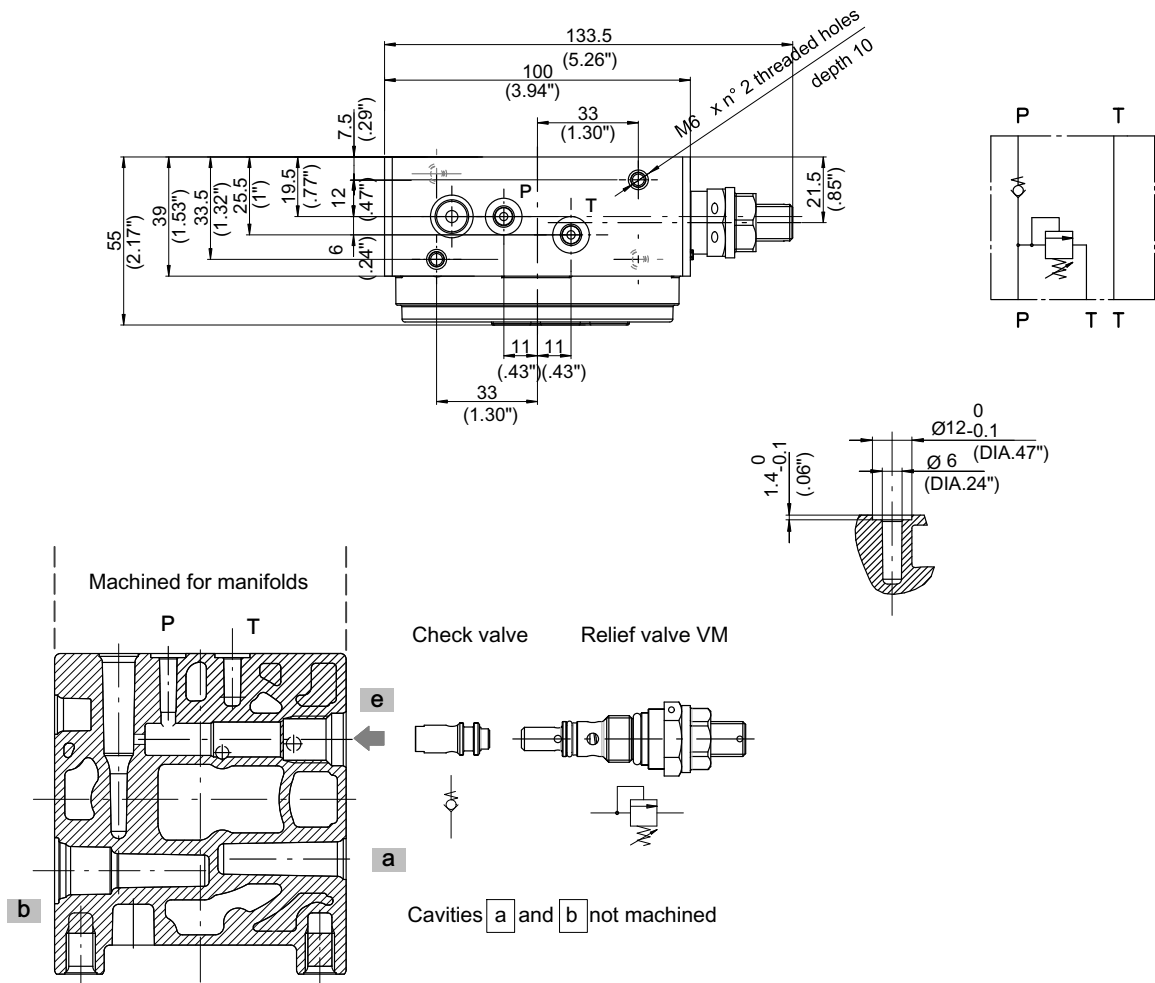

Type	For manifolds
UP50K03	Section 8 of catalogue



## 1.3 Housing UP50: K17-K04-K41-K42-K46 (threaded ports)

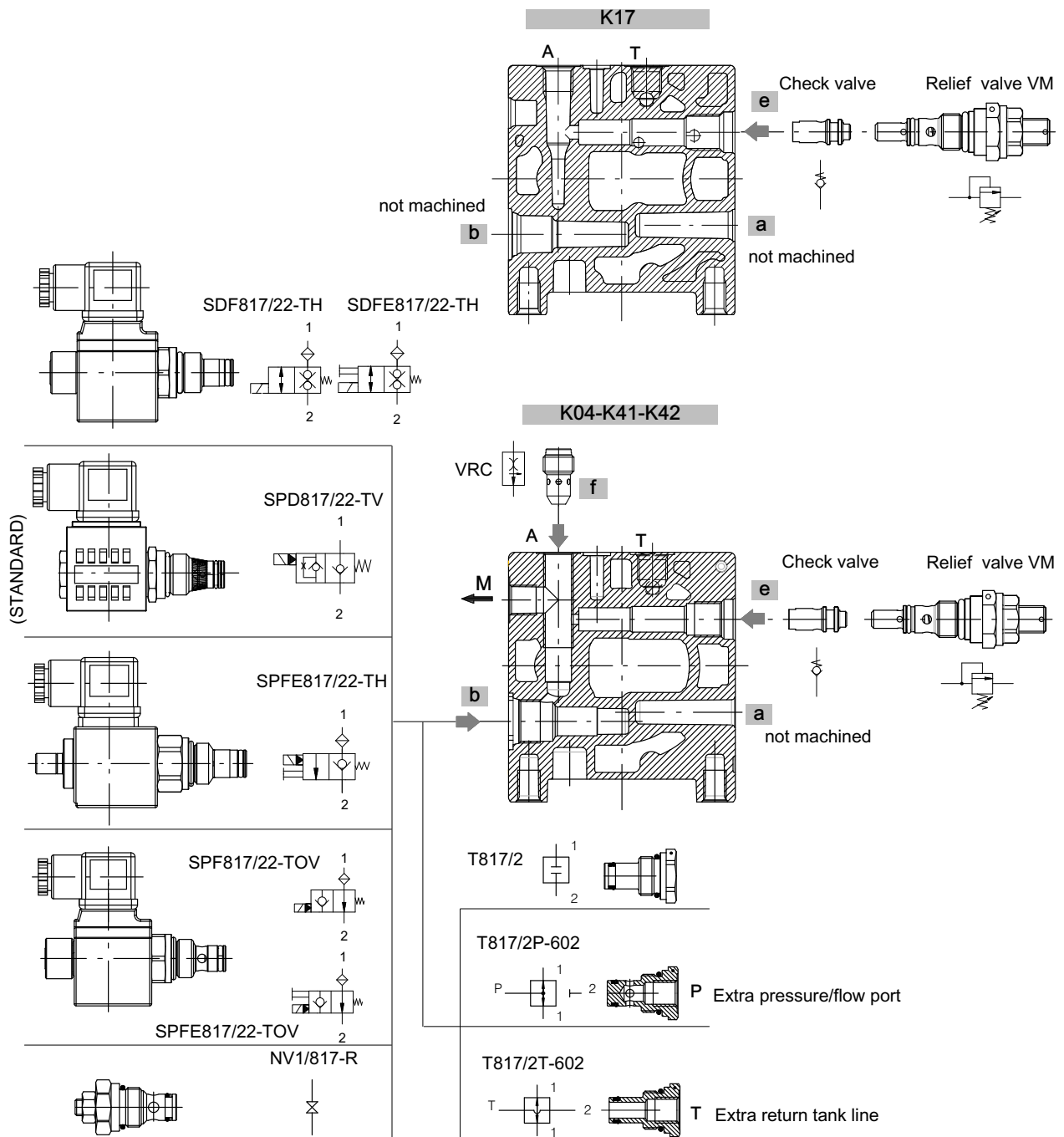

### 1.3.1 K17 - Housing with P-T threaded ports

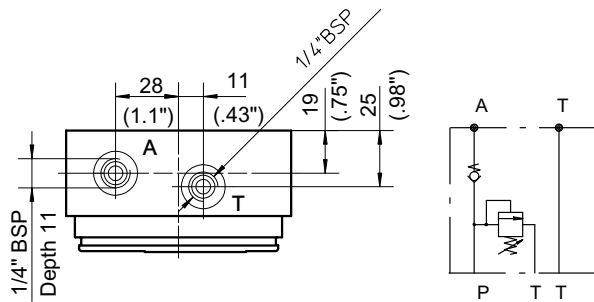

Type	Port A	Port T
UP50K17	1 / 4" BSP	1 / 4" BSP

### 1.3.2 K04 - Housing with A threaded port and integrated unloading valve

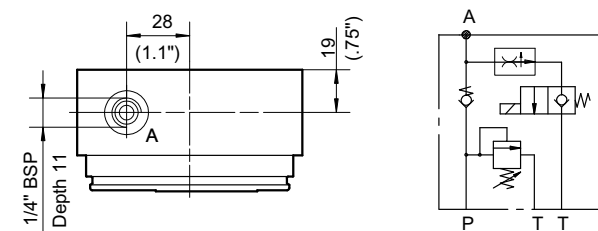

Type	Port A
UP50K04	1 / 4" BSP

### 1.3.3 K41 - Housing with A - T threaded ports and integrated unloading valve

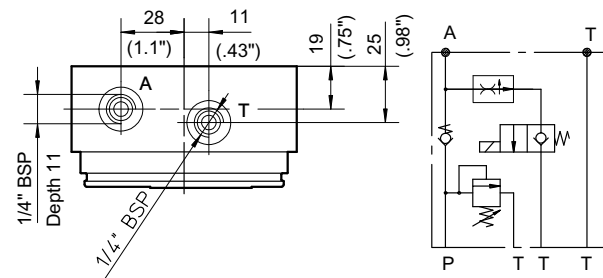

Type	Port A	Port T
UP50K41	1 / 4" BSP	1 / 4" BSP

### 1.3.4 K42 - Housing with A - M threaded ports and integrated unloading valve

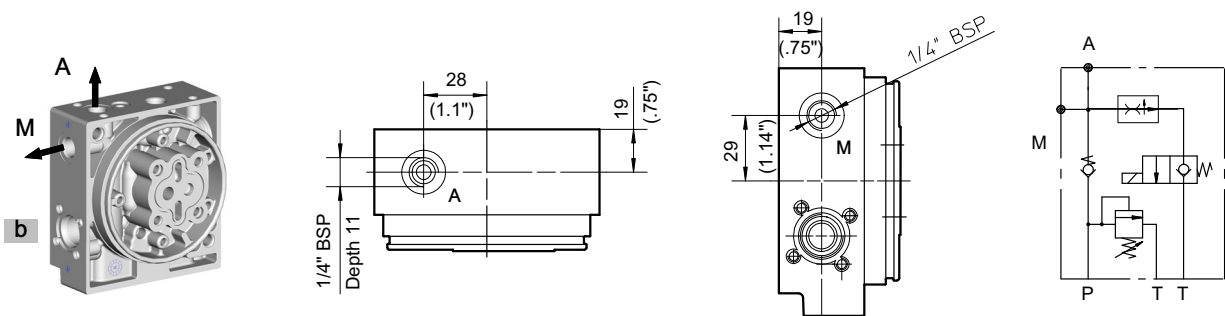

Type	Port A	Port M
UP50K42	1 / 4" BSP	1 / 4" BSP

## 1.3.5 K46 - Housing with threaded ports, integrated unloading valve and interface for the external manifold with emergency hand pump (4030 - 4031)

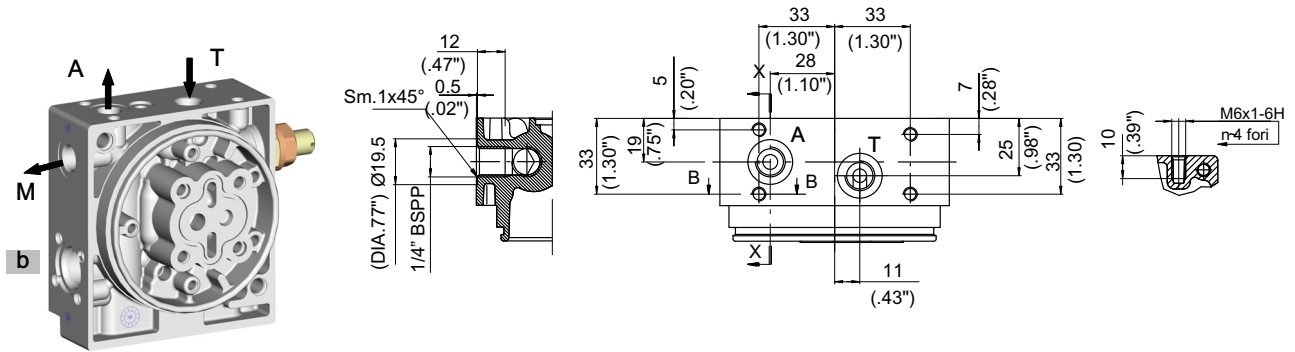

Type	Port A	Port T	Port M
UP50K46	1/4" BSP	1/4" BSP	1/4" BSP plugged

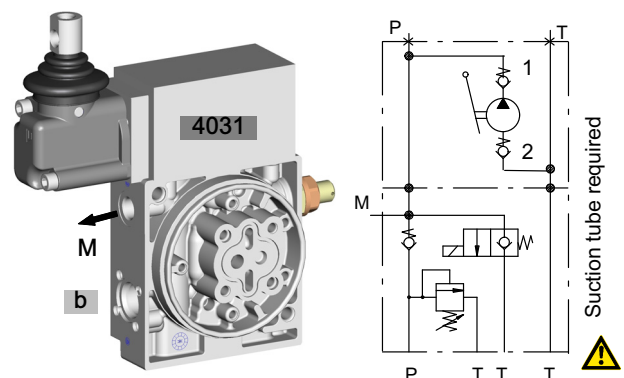
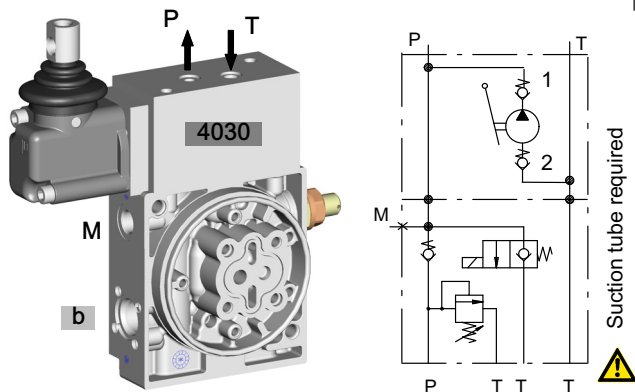
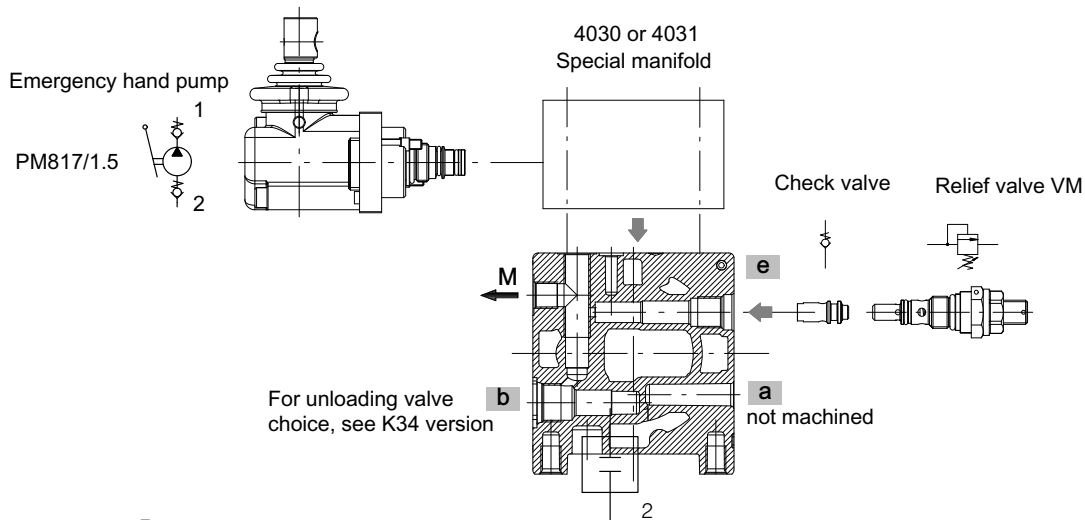
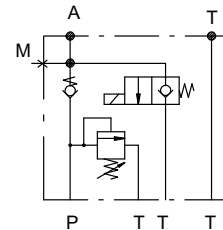

Type	Port P	Port T	Port M	Hand pump manifolds
UP50K46	-	-	1/4" BSP plugged	Section 7.6 of catalogue

Type	Port P	Port T	Port M	Hand pump manifolds
UP50K46	-	-	1/4" BSP	Section 7.6 of catalogue

1.4 Housing UP50K50-K52 (Reversible circuit) with threaded ports

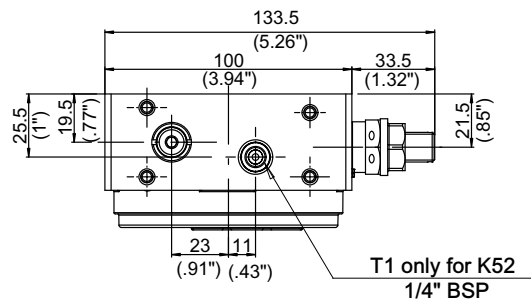
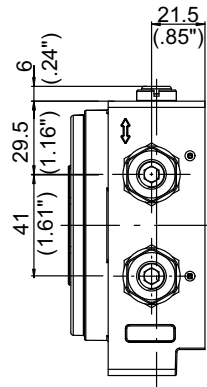
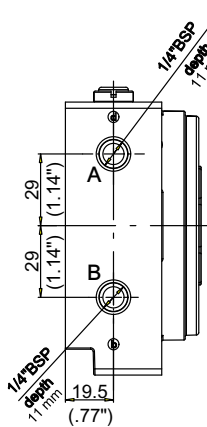
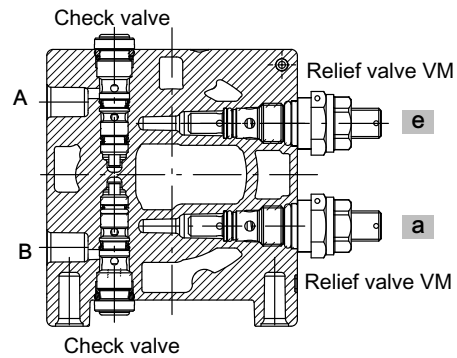
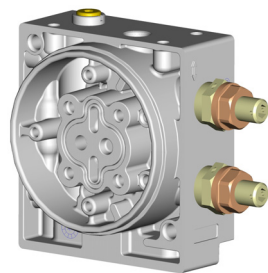

T1 only for K52  
1/4" BSP

**K50**

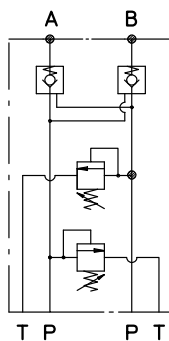

**K52**

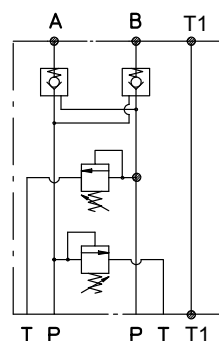

Type	Port A	Port B
UP50K50	1/4" BSP	1/4" BSP

Type	Port A	Port B	Port T1
UP50K52	1/4" BSP	1/4" BSP	1/4" BSP

### 1.5 Preassembled housing

The table summarizes part number to be stated in the event that is wished to order the housing sub-assembly fitted with shaft seal only.

Remember that the preassembled housing is supplied without the O-Rings kit, which must be ordered separately.

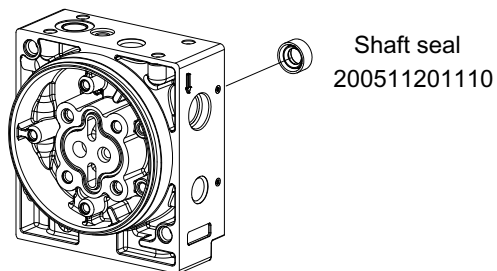

Body type	Complete code with shaft seal
UP50K03	200740210170
UP50K34	200740210180
UP50K17	200740220190
UP50K04	200740210200
UP50K41	200740230480
UP50K42	200740230470
UP50K46	200740290080
UP50K50	200740250110
UP50K52	200740250120

#### 1.5.1 O-rings kit

SK03 O-Rings kit 200974200530

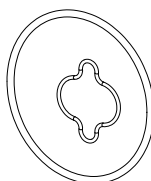

## 2 Gear pumps

### 2.1 Technical information

#### 2.1.1 Material

Cover: Pressure diecast aluminium alloy  
Body: Extruded aluminium alloy  
Gears: Casehardened and hardened steel.

Bearings: Aluminium alloy.  
Seals: NBR.

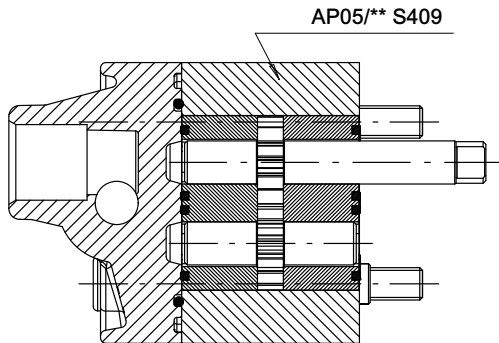

#### 2.1.2 Suitable fluids

Only mineral oil based hydraulic fluids responding to ISO/DIN standard should be used.

Viscosity range:

- recommended 20 - 120 mm<sup>2</sup>/s (cSt)
- admitted up to 700 mm<sup>2</sup>/s (cSt)

Operating temperature range: -15 +80 °C

For other fluids consult our Sales Department.



**ATTENTION!** Use of pumps at temperatures above 80°C must always be agreed upon with our Technical Office, and in any case this can cause a significant worsening in the volumetric efficiency. For use under conditions different from those indicated in this catalogue, please contact our Sales Department.

#### 2.1.3 Inlet

Absolute pressure at the pump inlet must be  
 $V > 0.75 \text{ bar (11 PSI)}$

Accordingly, avoid:

- significant differences in height of pump and tank
- long pipeline runs
- sharp bends, restrictions, etc. causing turbulent flow

In certain applications, inlet pressure may be higher than 1 bar (14.3 PSI), or at any rate higher than atmospheric.

For pumps with standard configuration, the pressure registering at the gauge M1 should be:

$$M1 < 3.5 \text{ bar (50 PSI)}.$$

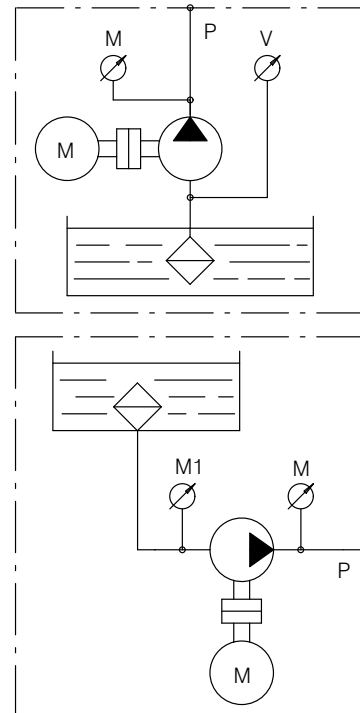

## 2.1.4 Outlet

Pressure levels:

P1 = continuous operating pressure

P2 = intermittent operating pressure

P3 = peak pressure

The recommended delivery pipe oil speed is between:

$v = 2 - 5 \text{ m/s}$

In the next pages are indicated the performances for each pump.

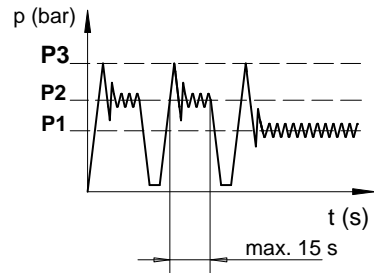

AP05 Pump type	Displacement		L		Max pressure					
	cm <sup>3</sup> /rev	Cu.In.P.R.	mm	inch.	P1		P2		P3	
					bar	PSI	bar	PSI	bar	PSI
AP05/1.6 S.409	1.6	.10	74.7	2.94	170	2400	180	2600	200	2900

## 2.1.5 Calculating the specifications of a gear pump

The equations for calculating the following parameters are given below:

**V<sub>c</sub>** = (cm<sup>3</sup>/g) pump displacement;

**n** = (g/min) Drive shaft rpm;

**Q** = (l/min) flow rate;

**P** = (bar) Operating pressure;

**M** = (Nm) Torque;

**N** = (kW) Power

$\eta_v$  = (%) Volumetric efficiency

$\eta_m$  = (%) Mechanical efficiency

$\eta_t$  = (%) Total efficiency

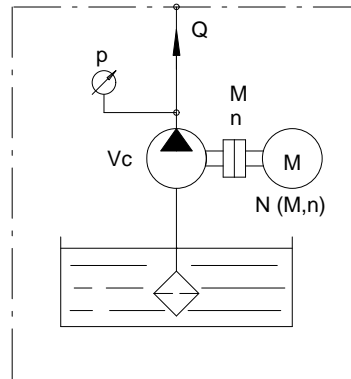

$$Q = \frac{V_c \cdot n}{100000} \cdot \eta_v$$

$$V_c = \frac{100000 \cdot Q}{n \cdot \eta_v}$$

$$n = \frac{100000 \cdot Q}{V_c \cdot \eta_v}$$

$$N = \frac{V_c \cdot n \cdot p}{6000 \cdot \eta_m}$$

$$N = \frac{Q \cdot p}{6 \cdot \eta_t}$$

$$p = \frac{N \cdot 6 \cdot \eta_t}{Q}$$

$$p = \frac{N \cdot 6000 \cdot \eta_m}{V_c \cdot n}$$

$$M = 9555 \cdot \frac{N}{n}$$

$$\eta_t = \eta_v \cdot \eta_m$$

Example

AP05/1.6  $V_c = 1.6 \text{ cm}^3/\text{r}$   $n = 1500 \text{ r/min}$   $p = 170 \text{ bar}$   $\eta_v = 94\%$   $\eta_m = 87\%$

$$Q = \frac{1.6 \cdot 1500}{100000} \cdot 94 = 2.26 \text{ l/min.}$$

$$\eta_t = 0.94 \cdot 0.87 = 0.82 = 82\%$$

$$N = \frac{2.26 \cdot 170}{6 \cdot 82} = 0.78 \text{ kW}$$

$$M = 9555 \cdot \frac{0.78}{1500} = 4.97 \text{ Nm}$$

## 2.2 Gear pumps AP05/\*\* S409 - Counterclockwise rotation

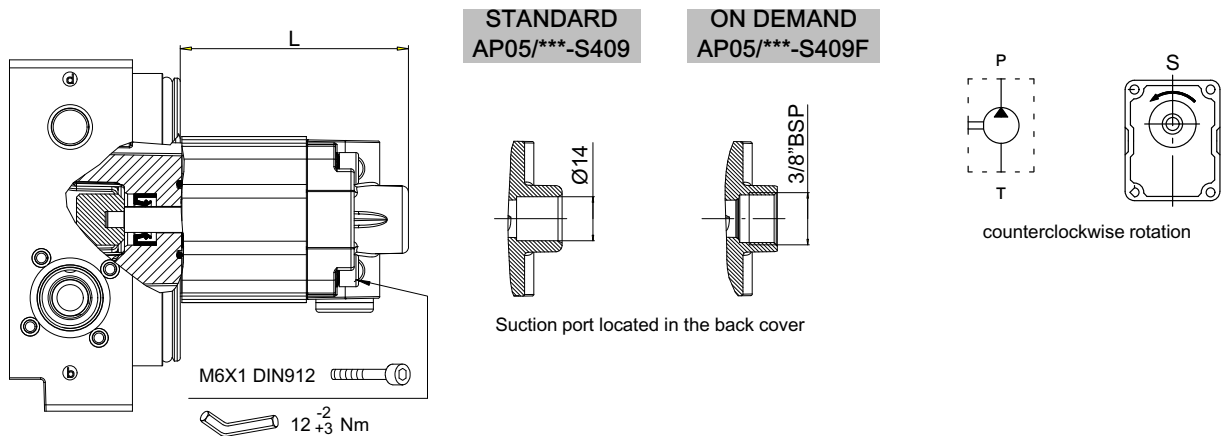

Example	Pump	Series
2	A P 0 5 / 0 , 2 5	S 4 0 9

### Standard version

AP05	Displacement		Order code	L		Max. pressure						n. min.		n. max.
	Pump type S.409	cm <sup>3</sup> / rev				Cu.In. P.R.	P1		P2		P3		P<10 0 bar	P>10 0 bar
				bar	PSI		bar	PSI	bar	PSI				
AP05/0.25 S.409	0.25	.015	200748120050	63	2.48	170	2460	180	2610	200	2900	800	3000	7000
AP05/0.5 S.409	0.5	.031	200748130050	65	2.56	190	2750	210	3040	230	3330	650	3000	7000
AP05/0.75 S.409	0.75	.046	200748140050	67	2.64	190	2750	210	3040	230	3330	650	1500	7000
AP05/0.9 S.409	0.9	.055	200748150050	68.5	2.69	190	2750	210	3040	230	3330	650	1500	7000
AP05/1.2 S.409	1.2	.073	200748160050	71	2.79	170	2460	180	2610	200	2900	550	1500	6000
AP05/1.6 S.409	1.6	.098	200748180060	74.7	2.94	170	2460	180	2610	200	2900	550	1500	6000
AP05/2.3 S.409	2.3	.140	200748190040	80.6	3.17	150	2170	160	2300	180	2610	550	1500	4500

### On demand version, only

AP05	Displacement		Order code	L		Max. pressure						n. min.		n. max.
	Pump type S.409F	cm <sup>3</sup> / rev				Cu.In. P.R.	P1		P2		P3		P<100 bar	P>100 bar
				bar	PSI		bar	PSI	bar	PSI				
AP05/0.25 S.409F	0.25	.015	200748120170	63	2.48	170	2460	180	2610	200	2900	800	3000	7000
AP05/0.5 S.409F	0.5	.031	200748130150	65	2.56	190	2750	210	3040	230	3330	650	3000	7000
AP05/0.75 S.409F	0.75	.046	200748140090	67	2.64	190	2750	210	3040	230	3330	650	1500	7000
AP05/0.9 S.409F	0.9	.055	200748150090	68.5	2.69	190	2750	210	3040	230	3330	650	1500	7000
AP05/1.2 S.409F	1.2	.073	200748160150	71	2.79	170	2460	180	2610	200	2900	550	1500	6000
AP05/1.6 S.409F	1.6	.098	200748180080	74.7	2.94	170	2460	180	2610	200	2900	550	1500	6000
AP05/2.3 S.409F	2.3	.140	200748190050	80.6	3.17	150	2170	160	2300	180	2610	550	1500	4500

## 2.3 Gear pumps APR05/\*\* -339F - Reversible

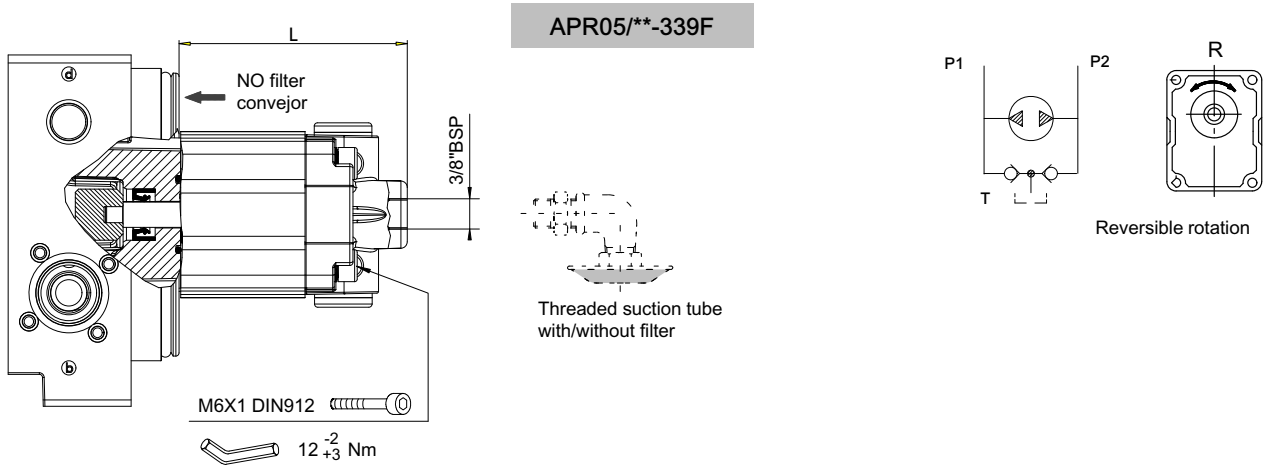

Example	Pump	Series
2	A P R 0 5 / 0 , 5	- 3 3 9 F

AP05	Displacement		Order code	L		Max. pressure						n. min.		n. max.
	cm <sup>3</sup> /rev	Cu.In. P.R		mm	inch.	P1		P2		P3		P<100 bar	P>100 bar	P>P1
APR05/0.25-339F	0.25	.015	200748120180	63	2.48	150	2170	160	2320	180	2610	800	3000	7000
APR05/0.5-339F	0.5	.030	200748130165	65	2.56	170	2460	190	2750	210	3040	650	3000	7000
APR05/0.75-339F	0.75	.045	200748140100	67	2.64	170	2460	190	2750	210	3040	650	1500	7000
APR05/0.9-339F	0.9	.055	200748150100	68.5	2.69	170	2460	190	2750	210	3040	650	1500	7000
APR05/1.2-339F	1.2	.075	200748160210	71	2.79	150	2170	160	2320	180	2610	550	1500	6000
APR05/1.6-339F	1.6	.10	200748180110	74.7	2.94	150	2170	160	2320	180	2610	550	1500	6000
APR05/2.3-339F	2.3	.140	200748190060	80.6	3.17	130	1880	140	2030	160	2320	550	1500	4500

### 3 Tanks

#### 3.1 Plastic tanks

##### 3.1.1 Technical information

Material: Polypropylene (PP)  
Color: neutral, translucent allowing visual check on the oil level

Conditions of use:  
Operating temperature range: -15 / +70°C  
Suitable fluids: use only mineral oil based hydraulic fluids responding to ISO - DIN standards.  
Hydrocarbon based fluids (e.g. benzene, benzol, etc.) must not be used.

Versions: Tanks are available in numerous versions, allowing installation of the power pack in different horizontal and vertical positions.



**ATTENTION!:**

Whilst the fixing and sealing systems are designed for operation under the most heavy-duty conditions, the tank must be securely anchored when fitted to mobile equipment, and when subject to shocks and heavy vibrations generally, by means of flexible clips located in the recesses provided. Care must be taken never to stress and deform the tank when tightening the anchorages.

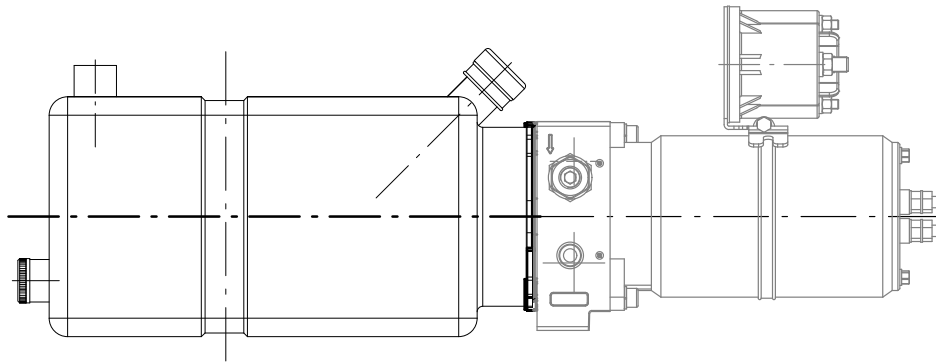

##### 3.1.2 Round plastic tanks from 0.5 to 1 litres

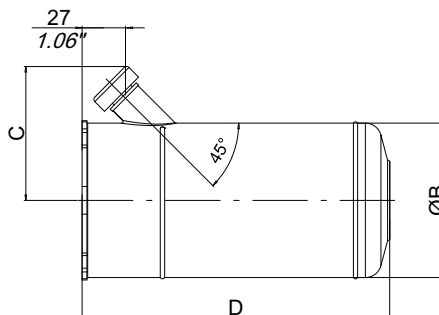

Nom capacity		Type/Code		Fixing Position	A		B		C		D	
L	U.S.G.P.M.				mm	inch	mm	inch	mm	inch	mm	inch
0.5	0.132	P-005R-A	200973210090	P01-P02-P03-P04 P05-P15-P25-P35	-		96	3.78	82.5	3.25	126	4.96
1	0.26	P-010R-A	200973220040		-		96	3.78	82.5	3.25	190	7.48

## 3.1.3 Square plastic tanks from 1 to 4 litres

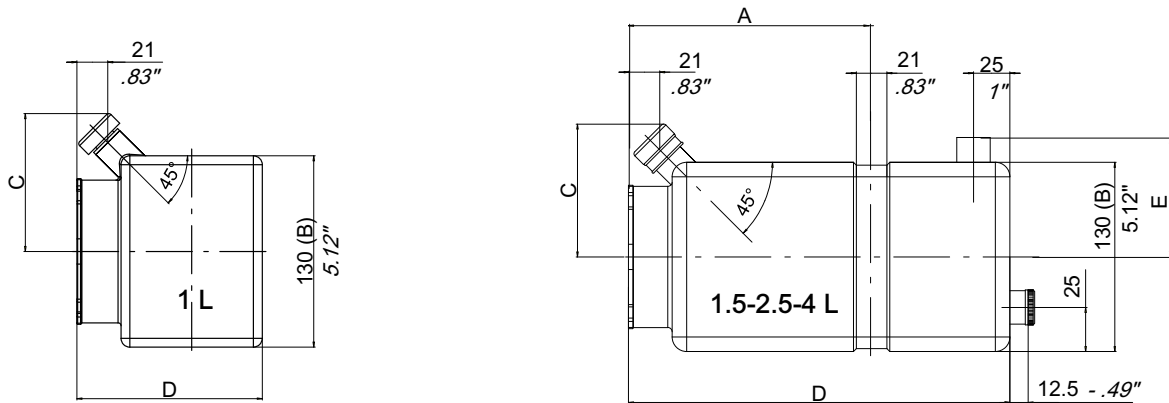

Nom capacity		Type	Code	Fixing Position	A		B		C		D		E	
Litres	U.S.G .P.M.				mm	inch	mm	inch	mm	inch	mm	inch	mm	inch
1	0.26	P-010Q-A	200973220030	P01-P02-P03-P04 P05-P15-P25-P35	-		130	5.12	99	3.9	126	4.96	82	3.23
1.5	0.40	P-015Q-A	200973230030		-				99	3.9	159	6.26		
1.5	0.40	P-015Q-E	200973230070		-				99	3.9	159	6.26		
1.5	0.40	P-015Q-D	200973230060	P01-P02-P03-P04	-				99	3.9	159	6.26		
1.5	0.40	P-015Q-B	200973230040		-				99	3.9	159	6.26		
1.5	0.40	P-015Q-F	200973230080		-				99	3.9	159	6.26		
2.5	0.66	P-025Q-A	200973240020	P01-P02-P03-P04 P05-P15-P25-P35	167	6.6			99	3.9	262	10.3		
2.5	0.66	P-025Q-E	200973240060		167	6.6			99	3.9	262	10.3		
2.5	0.66	P-025Q-D	200973240050		167	6.6			99	3.9	262	10.3		
2.5	0.66	P-025Q-B	200973240030	P01-P02-P03-P04	167	6.6			99	3.9	262	10.3		
2.5	0.66	P-025Q-F	200973240070		167	6.6			99	3.9	262	10.3		
4.0	1.05	P-040Q-A	200973260020		P01-P02-P03-P04 P05-P15-P25-P35	232			9.13	99	3.9	327		
4.0	1.05	P-040Q-E	200973260060	232		9.13	99	3.9	327	12.9				
4.0	1.05	P-040Q-D	200973260050	232		9.13	99	3.9	327	12.9				
4.0	1.05	P-040Q-B	200973260030	P01-P02-P03-P04	232	9.13	99	3.9	327	12.9				
4.0	1.05	P-040Q-F	200973260070		232	9.13	99	3.9	327	12.9				

### Horizontal and vertical mounting

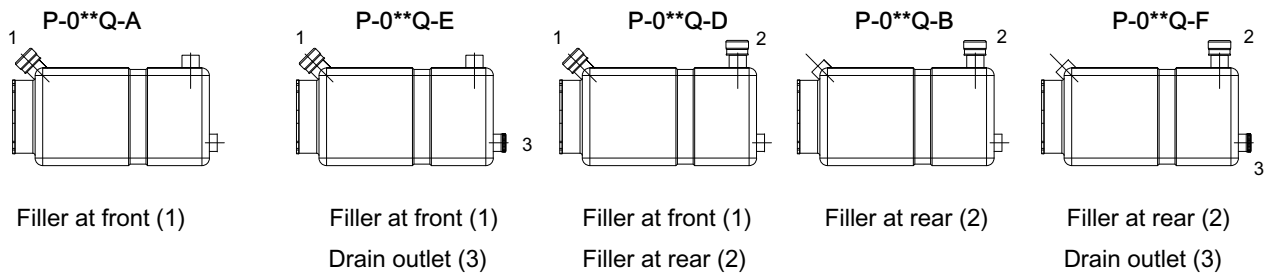

### 3.2 Fitment and fixing positions

#### 3.2.1 Fixing position: Horizontal

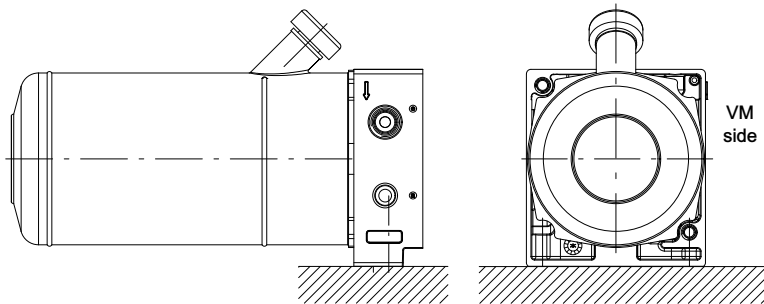

Assembling position

P01

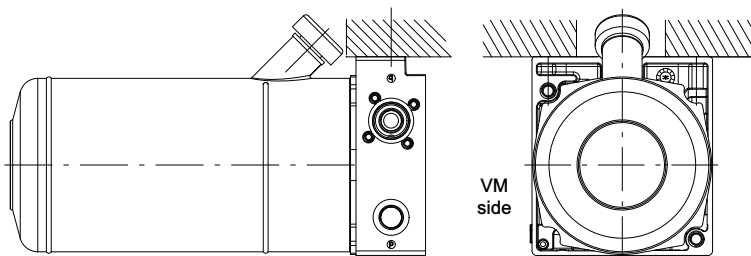

Assembling position

P02

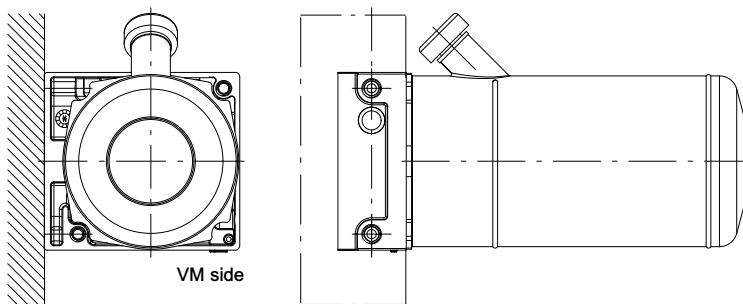

Assembling position

P03

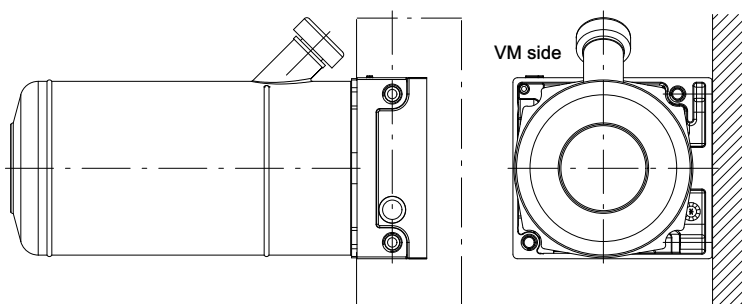

Assembling position

P04

Example

	Tank						Fitting				Pos.		
3	P	0	1	0	R	A					P	0	1

## 3.2.2 Fixing position : Vertical

Assembling position P05

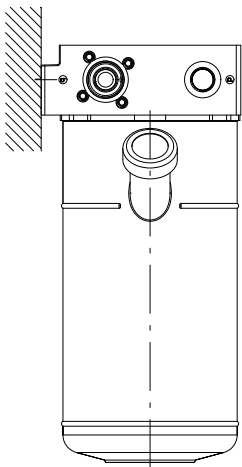
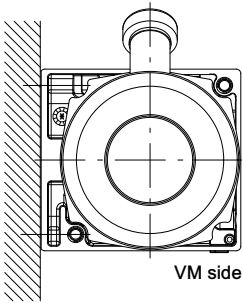

Assembling position P15

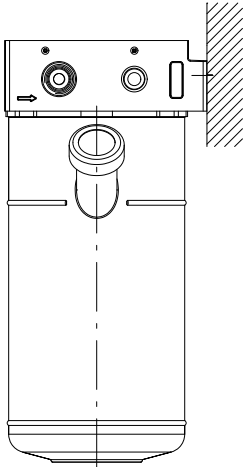
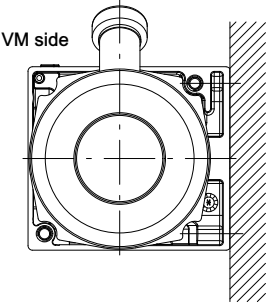

Assembling position P25

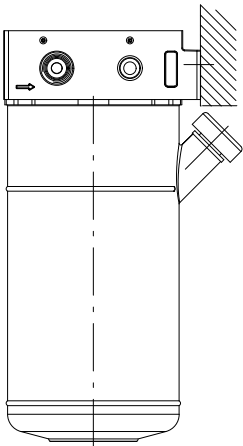
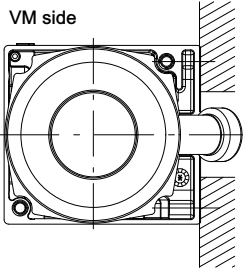

Assembling position P35

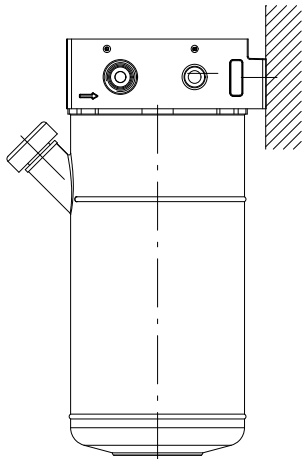
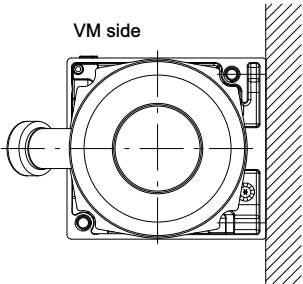

Example

	Tank						Fitting				Pos.			
3	P	0	1	0	R	-	A					P	1	5

### 3.2.3 Filler cap and drain plug for plastic tank

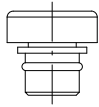

PLFP1-02 Filler cap  
Code: 200527099904



(\*)  
+

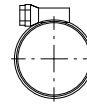

PLDP1-01 Oil drain plug + fixing clip Ø 16÷27  
Code: 200778800230

### 3.2.4 Fixings kit for plastic tank

FIX04 code: 200771900230

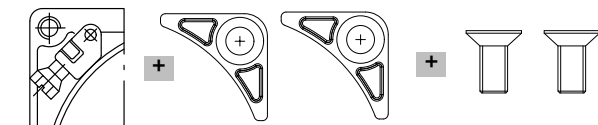

200544116019 Tank fixing clip (q.ty 1)

200677400420 Tank fixing bracket (q.ty 2)

200523103504 M8x16 fixing screw/braket (q.ty 2)

### 3.2.5 Fixings kit for steel collar

FIX05 code: 200771900380

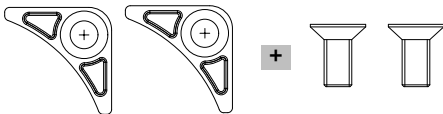

200677400420 Tank fixing bracket (q.ty 2)

200523103504 M8x16 fixing screw/braket (q.ty 2)

Admitted torque for fixing kit

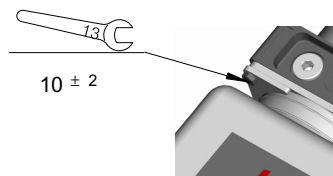

## 3.3 Steel collar

### 3.3.1 Technical information

Materials: Sheet metal.

Color: not painted

Condition of use: Suitable fluids: mineral oil based hydraulic fluids responding to ISO -DIN standards.

Operating temperature range: -15 / +80°C

Hydrocarbon based fluids (e.g. benzene, benzol, etc.) must not be used.

Type: LSC02  
Code: 200609400020

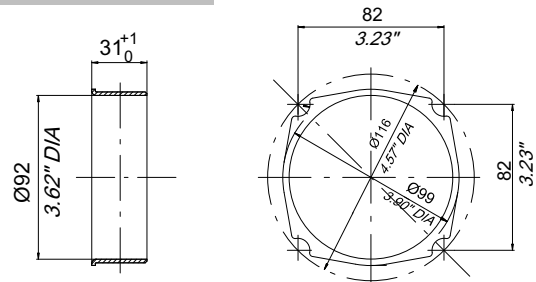



**ATTENTION!**  
**Notes of fitment**

Care needs to be taken over the following aspects of fitting and securing the tank. For horizontal mounting arrangements, the clip fastener must be positioned within the limits indicated in picture A. Other positions can result in deformation of the tank, and consequently in the risk of leakage. The clip should not be positioned against the filler as shown in pack housing, compressing the spigot O-Ring (fig.C).

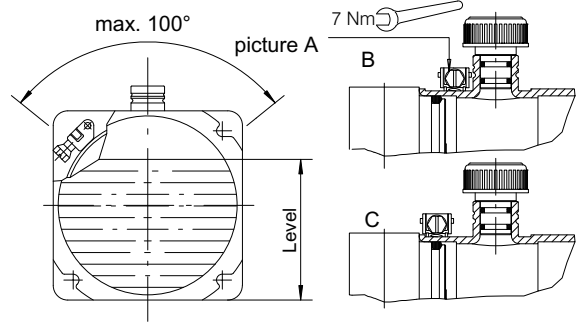

**Horizontal assembling for power pack with plastic/metal tanks**

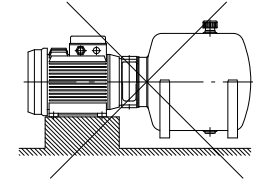
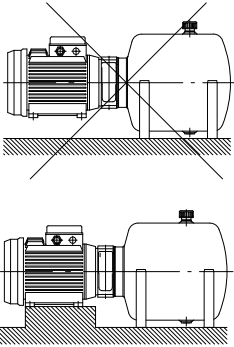

**IMPORTANT!**  
Overhanging assembling configurations for motor or tank are not admitted

**Vertical assembling for power pack with plastic/metal tanks**

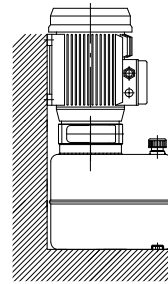

**IMPORTANT!**

For hydraulic units assembling electric motors equal or higher than 1.5 HP- 1.1KW, it's recommended to order the B34 frame size version. Consequently it is recommended to fix the hydraulic unit by the electric motor feet or when possible both electric motor and tank feet.

## 4 Suction/return assembly kits

### 4.1 Suction assembly kits for plastic tanks horizontal positions for standard AP05/\*\*\*-S409 Ø14

Pump S409	Tank types					
	P-005R-A	P-010R-A	P-010Q-A	P-01.5Q-*	P-02.5Q-*	P04.0Q-*
AP05/0.25	200785000050 GA39	200785000050 GA39	200785000070 GA41	200785000070 GA41	200785000070 GA41	200785000070 GA41
AP05/0.5						
AP05/0.75						
AP05/0.9						
AP05/1.2						
AP05/1.6	Assembling not possible					
AP05/2.3						

### 4.2 Suction assembly kits for plastic tanks vertical positions for standard AP05/\*\*\*-S409 Ø14

Pump S409	Tank types					
	P-00,5R-A	P-01,0R-A	P-01,0Q-A	P-01,5Q-*	P-02,5Q-*	P04,0Q-*
AP05/0.25	200785000060 GA40	200785000020 GA36	200785000060 GA40	200785000090 GA43	200785000030 GA37	200785000150 GA49
AP05/0.5						
AP05/0.75						
AP05/0.9	200785000100 GA44	200785000130 GA47	200785000100 GA44	200785000120 GA46	200785000140 GA48	
AP05/1.2						
AP05/1.6	Assembling not possible			200785000110 GA45		
AP05/2.3						

\* A-B-D-E-F versions

### 4.3 Suction assembly kits - Reversible version

For the combinations of the suction assembly kits, horizontal/vertical positions please consult our Sales Organisation

## 5 Electric motors

Electric motor available:

### 5.1 D.C. motors

Generally used for mobile applications

### 5.2 A.C. motors

Generally used for stationary applications

### 5.1 D.C. Electric motors

#### 5.1.1 Technical information

Available versions:

Voltage: 12-24 and 48 V

Power rating: 0.8 ÷ 3 kW.

For different input voltage and power rating, consult our Sales Department.

Direction of rotation:

Unless otherwise stated, all motors are specified clockwise

rotation, suitable for driving counterclockwise pump.

Type of winding:

D.C. motors can be manufactured in different types of field windings:

- Permanent magnets
- Series
- Compound

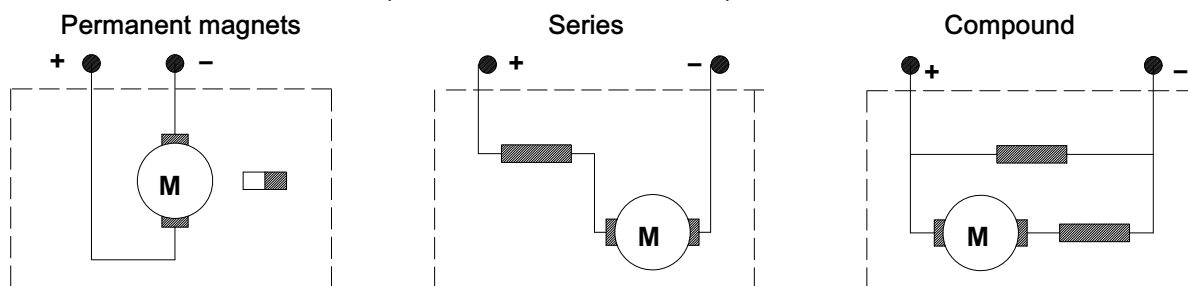

Insulation class:

The class of electric insulation reflects the maximum temperature the motor can register during operation without damage to the insulating material internally of the motor itself.

The following table indicates insulation classes to CEI 15-26.

Class	Y	A	E	B	F	H
Temperature (°C)	90	105	120	130	155	180

Type of duty:

To ensure selection of the electric motor best suited to a given set of operating conditions, the duty cycle needs to be verified. Duty cycles S1, S2 and S3 are defined below in accordance with CEI 2-3

Continuous duty S1:

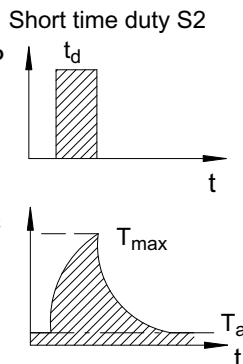
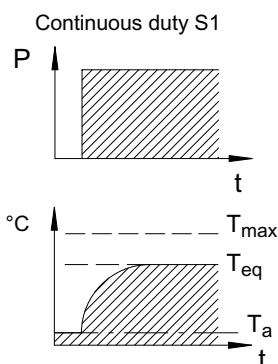

Operation on-load (steady conditions) for a period of indefinite duration, during which the motor reaches thermal equilibrium without exceeding the maximum permissible temperature.

Short time duty S2

Operation on-load (steady conditions) for a period of limited duration, denoted  $t_d$  in the diagram, during which maximum permissible temperature is reached, followed by an off-load period of duration sufficient for the temperature of the motor to return to ambient temperature.

Intermittent duty S3

A sequence of identical cycles, each 10 minutes in duration, the single cycle comprises a period of operation on-load  $t_d$ , during which the motor may reach its maximum permissible temperature, is reached, followed by an off-load period of limited duration  $t_m$ , insufficient for the temperature of the motor to return to ambient temperature.

The value of S3 indicates the duration of the on-load period  $t_d$  in relation to the overall cycle time  $t_p$ , as a percentage.

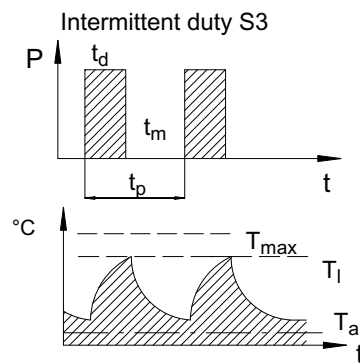

$$S3 = \frac{t_d}{t_d + t_m} \times 100$$

- P .. = load
- Teq = temperature at thermal equilibrium
- Tmax = maximum permissible temperature
- Tl = operating temperature

- Ta = ambient temperature
- td = duration of on-load period
- tm = duration of off-load period
- tp = duration of cycle (10 min.)

## Degree of protection:

This indicates the level of protection afforded in preventing contact between live parts of the motor and people or foreign matter generally, and preventing the penetration of water.

The degree of protection is indicated in accordance with CEI 2-16 by the initials IP and two identifying digits:  
Example:

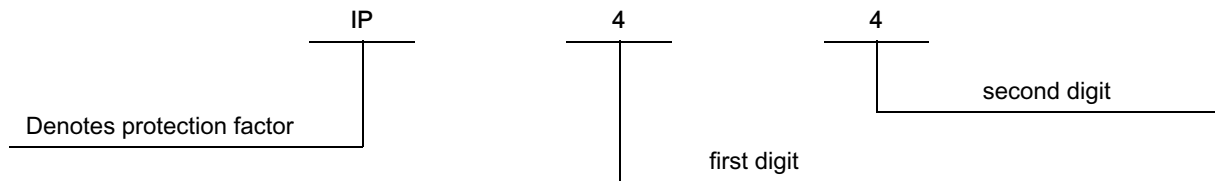

The first digit indicates the degree of protection afforded to the motor against contact with people or foreign bodies.

The second digit indicates the degree of protection afforded to the motor against the effects of penetration by water.

0	no protection	0	no protection
1	protection against solid bodies measuring > 50 mm	1	protection against water dripping vertically
2	protection against solid bodies measuring > 12 mm	2	protection against water dripping at 15° max
3	protection against solid bodies measuring > 2.5 mm	3	protection against rain
4	protection against solid bodies measuring > 1 mm	4	protected against water splash
5	protection against dust	5	protected against water spray

## 5.1.2 Characteristic curves

Characteristic curves are given for each motors, from which to establish pressure, flow rate and current consumption

values, and S2 and S3 duty cycles.

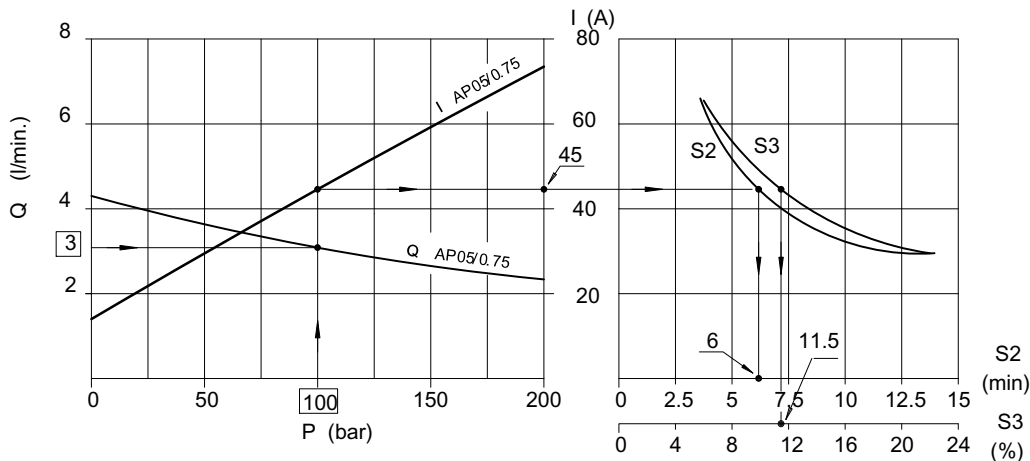

## 5.1.3 Example of how the graphs are used

### Required data

Flow rate  $Q = 3 \text{ l/l'}$

Pressure  $p = 100 \text{ bar}$

### Pump displacement

Determined by the intersection of the required  $p$  and  $Q$  curves.

In the example indicated, pump AP05/0.75 has the required  $p$  and  $Q$  specifications.

In the event that there is no point of intersection with any curve, a displacement as near as possible to the required flow rate should be selected.

### Current consumption

This is determined by taking a vertical line from the pressure value to its point of intersection with the  $I$  curve corresponding to the selected displacement.

In the example illustrated, current consumption is:

$I = 45 \text{ Ampere}$

### Type of use

Having established the current, the relationship of the S2 and S3 curves will give the following values:

S2 = 6 min. S3 = 11.5%

### Terminals

Unless otherwise stated, d.c. motors supplied by Bucher Hydraulics S.p.A. have two terminals.

Poles are identified in accordance with IEC34-8

A1 - A2 Armature

D1 - D2 Series

B1 - B2 Poles

E1 - E2 Parallel

### Electric diagram

A typical arrangement for connection of the motor to the power supply is shown in the diagram.

### 5.1.4 Mounting directions



The tie bolts must not be withdrawn completely while fitting motor, but retracted just for a short distance (30-50 mm max).

Once fitted to the power pack, the motor should be run off-load momentarily (5 seconds max) to verify its correct operation: supply power to the windings and measure the current drain, which must not exceed the following values:

24 V motor -  $I < 35$  Ampere  
 12 V motor -  $I < 70$  Ampere

#### Power cable

The wire selected for power connections must be of cross section appropriate for the rated current of the motor.

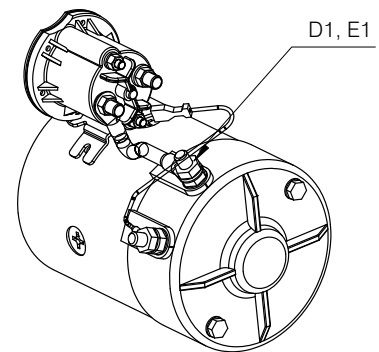
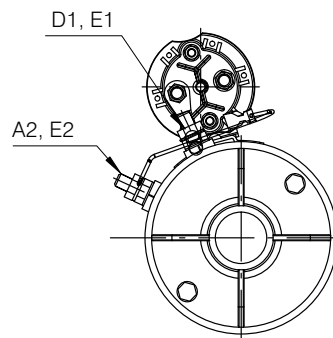
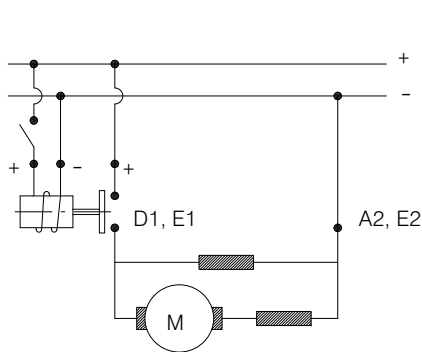

#### Tightening torques

When assembling the motor and power pack and securing the wires of the power cable to the motor terminals, observe the tightening torque values indicated.

#### Brush life

The brushes will wear down progressively with continued operation of the motor, and must be replaced when reduced to their minimum useful length.

Since the rate of wear on the brushes is dictated by the operating conditions and cannot therefore be broadly specified, consult our Sales Department for guidance.

Versions available on request

1. Motors with electrical device monitoring brush wear
2. Motors with thermocouple
3. Fan-cooled motors

Fan-cooled motors, 12 and 24 volt, are available, for further information, consult our Sales Department.

Bucher Hydraulics S.p.A. is not an electric motors manufacturer so these components come from third part. Bucher Hydraulics S.p.A. reserves the right to change the motor supplier without notice whenever considers it necessary. Minor dimensional and cosmetic differences may exist.

## 5.1.5 Starter Relays - Technical information

Versions:

Available voltage: 12-24 V

Heavy duty: for more arduous conditions

See relative table for technical data for:

- Electrical insulation class

- Type of duty

- Protection factor:

The level of protection is defined according to the same parameters as listed for electric motors.

- Contact life:

The contacts of the relay will wear down progressively during operation.

Since the rate of wear is dedicated by the type of duty and cannot therefore be broadly specified, consult our Sales dept. for guideline information.

Fitment to electric motor

Starter relays can be fitted to the frame of the motor by two different methods:

### 1. Direct

The relay is secured with screws, using holes already tapped in motor frame. In this instance there is one standard mounting position only.

### 2. Metal clip

The relay is secured by means of a clip encircling the motor frame and inserted through special slots in the feet of the relay itself.

In this instance, several mounting positions are possible.

Electrical diagram

A typical arrangement for connection of the relay to the electric motor is shown in the diagram.

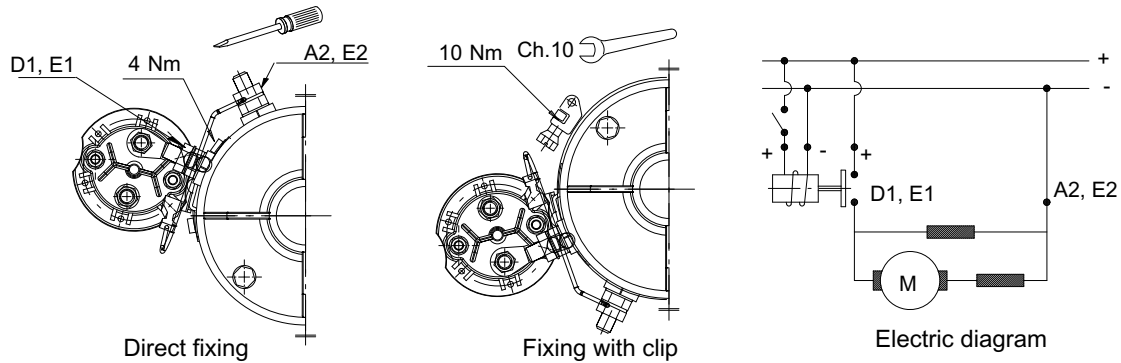

Heavy duty (STANDARD for wide range of DC el. motors)

Weight: 0.366 kg

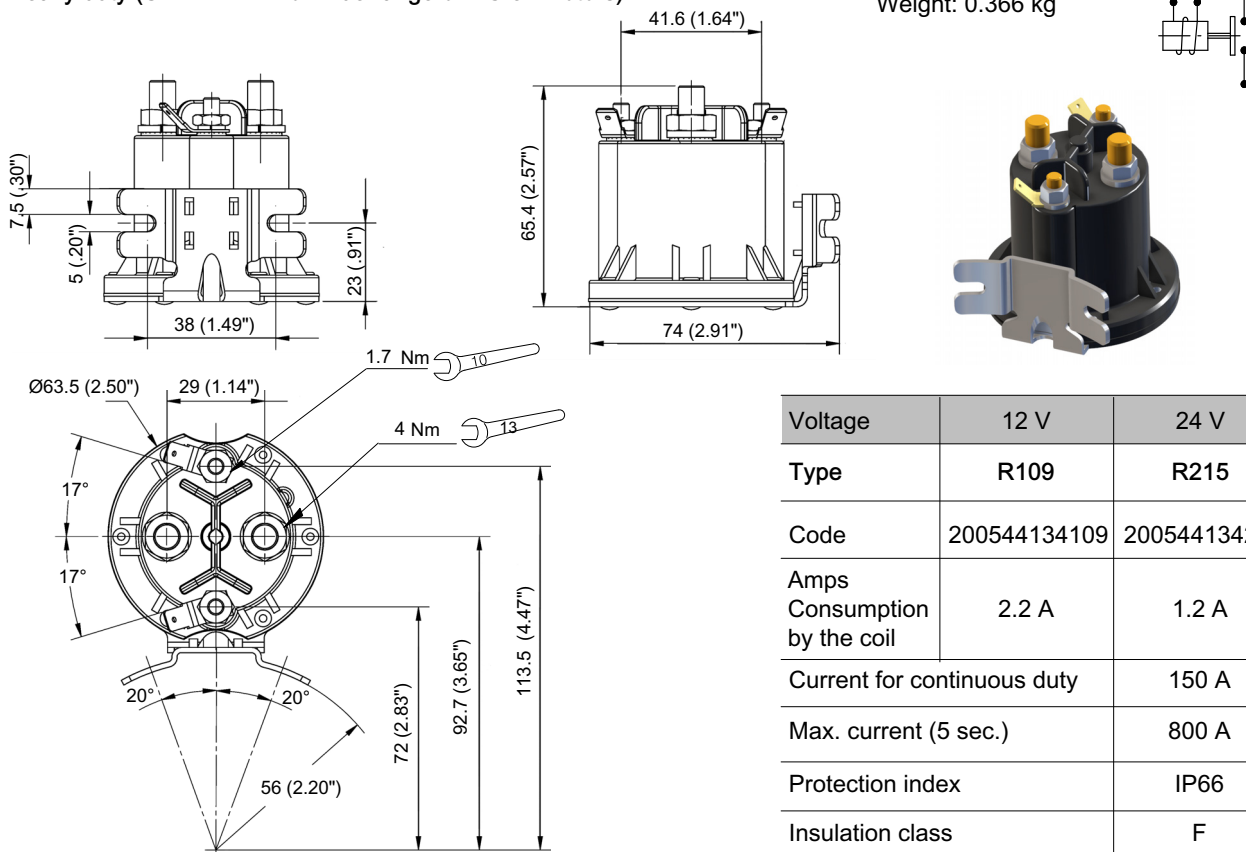

Voltage	12 V	24 V
Type	R109	R215
Code	200544134109	200544134215
Amps Consumption by the coil	2.2 A	1.2 A
Current for continuous duty		150 A
Max. current (5 sec.)		800 A
Protection index		IP66
Insulation class		F

Voltage	Nominal Power
12 V	500 W
24 V	500 W

Protection index: ..... IP54  
 Insulation class: ..... F  
 Type of winding: ..... Permanent magnets  
 Rating output power ..... : 500 W  
 Character of work: ..... S2 5 min, S3 17%

Weight: 2.50 Kg (4.96 lb)

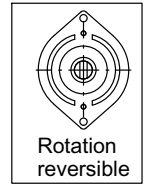
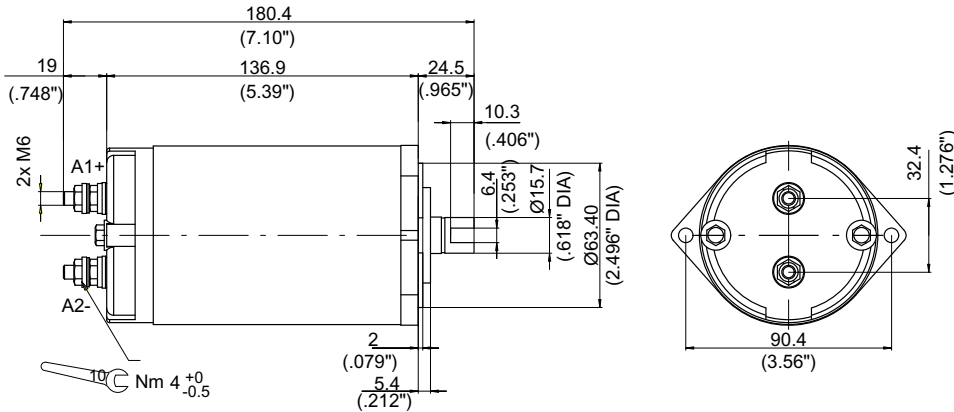

**Attention!**  
 Utilising unidirectional pump,  
 verify the connection.  
 The motor must rotate  
 clockwise (CW)

	Motor		Motor with relay
Rotation Reversible			
Type	C120PD/C0	C220PD/C0	
Code	200543912003	200543922004	
Relay			
Relay type			

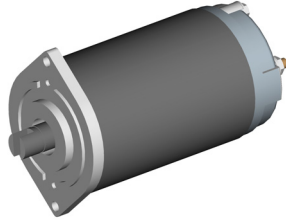

Motor mounting position

Standard positions

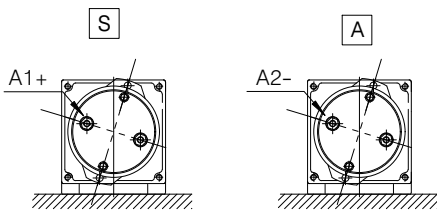

5	C	1	2	0	P	D	/	C	0	Pos.
---	---	---	---	---	---	---	---	---	---	------

Example

										Pos.
--	--	--	--	--	--	--	--	--	--	------

Relay mounting positions

Standard positions

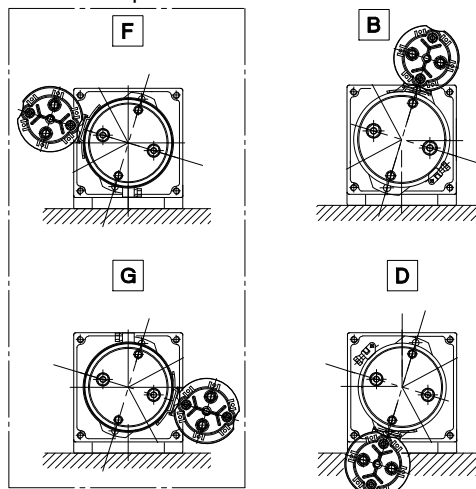

## 12 V - 500 W

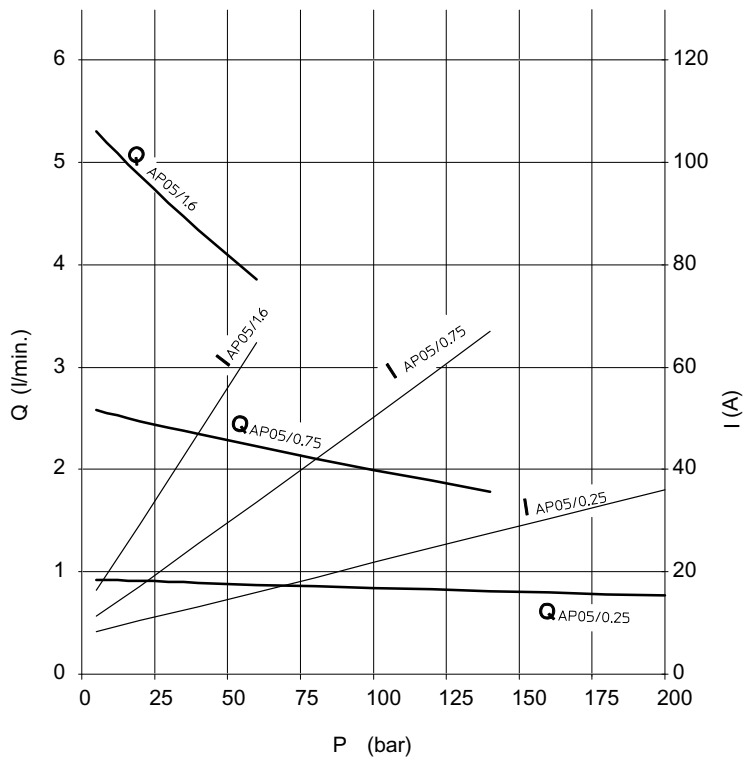

## 24 V - 500 W

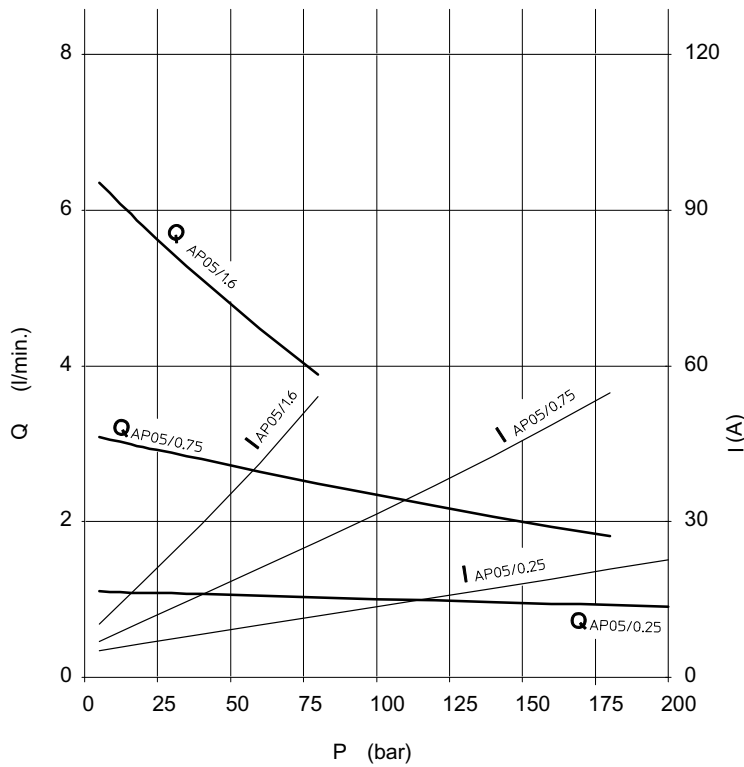

Voltage	Nominal Power
12 V	800 W
24 V	800 W

Protection index: ..... IP54  
 Insulation class: ..... F  
 Type of winding: ..... Permanent magnets  
 Relay fixing kit ..... 200709000090  
 Minimum brushes length: ..... 5 mm (0.2 inches)

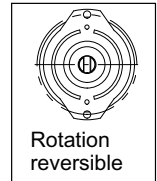
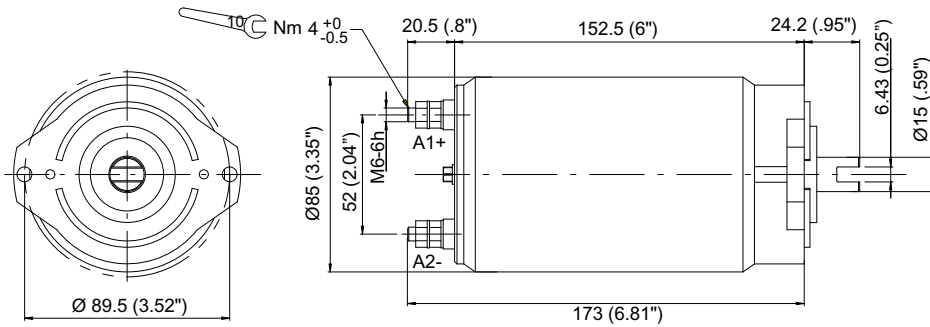

**Attention!**  
 Utilising unidirectional pump,  
 verify the connection.  
 The motor must rotate  
 clockwise

Weight: 3.70 Kg (8.15 lb)

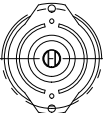
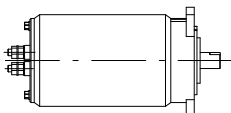
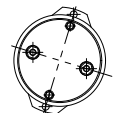
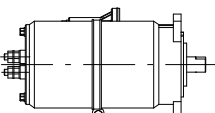
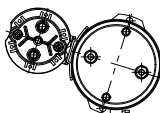
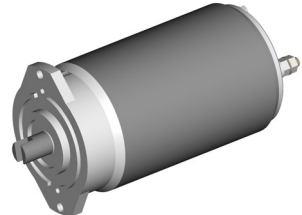
	Motor		Motor with relay		
					
Rotation reversible	12V-800W	24V-800W	12V-800W	24V-800W	
Type	C128PK/A0	C228PK/A0	C128PK/A0 + R109	C228PK/A0 + R215	
Code	200543912809	200543922801	200763310270	200763320300	
Relay			Standard		
Relay type			R109	R215	

Motor mounting position

Relay mounting positions

Standard positions

Standard positions

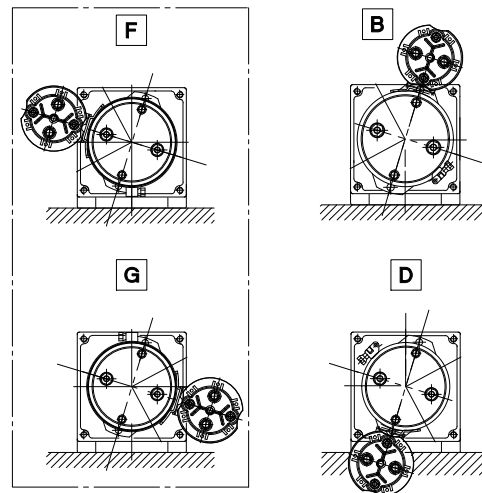
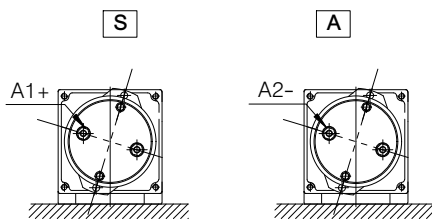

Electric motor										Pos.
5	C	2	2	8	P	K	/	A	0	S

Example

Relè					Pos.
R	2	1	5		F

**12 V - 800 W**  
I (A)

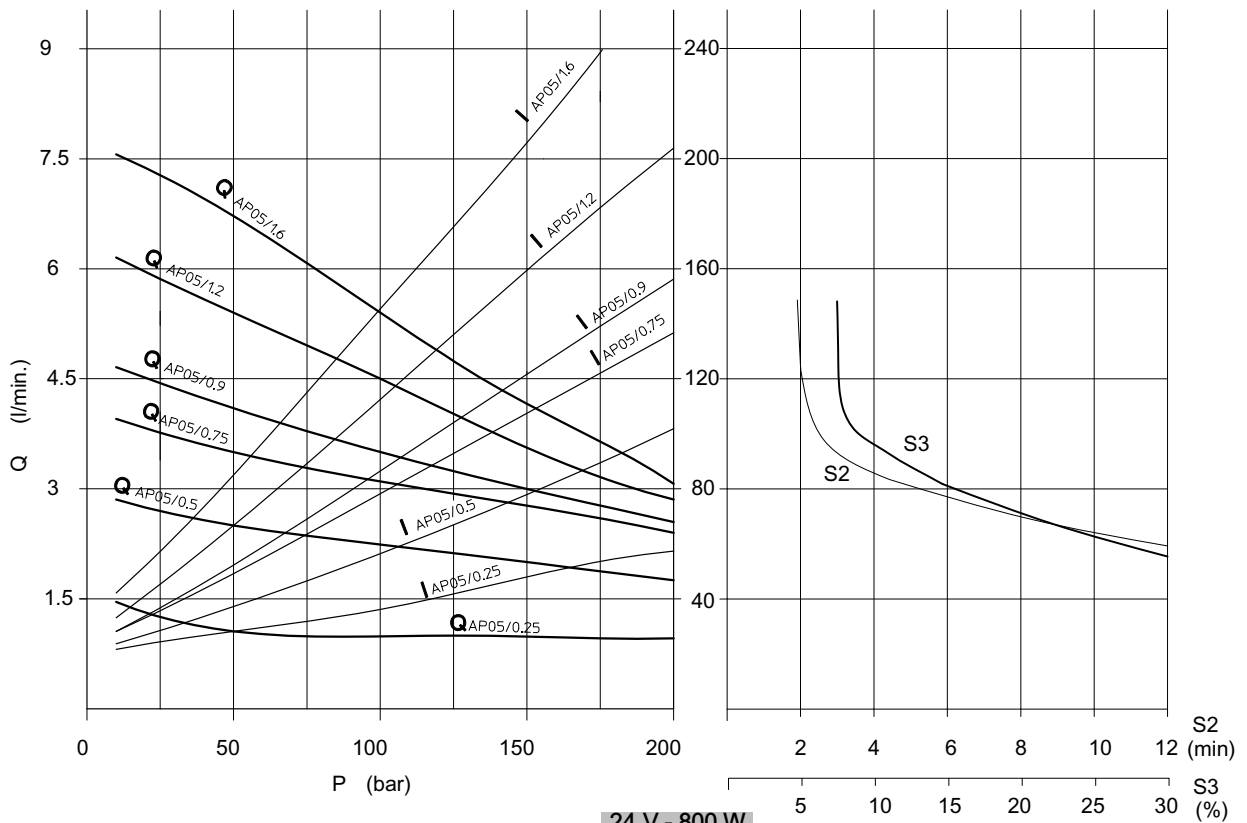

**24 V - 800 W**  
(A)

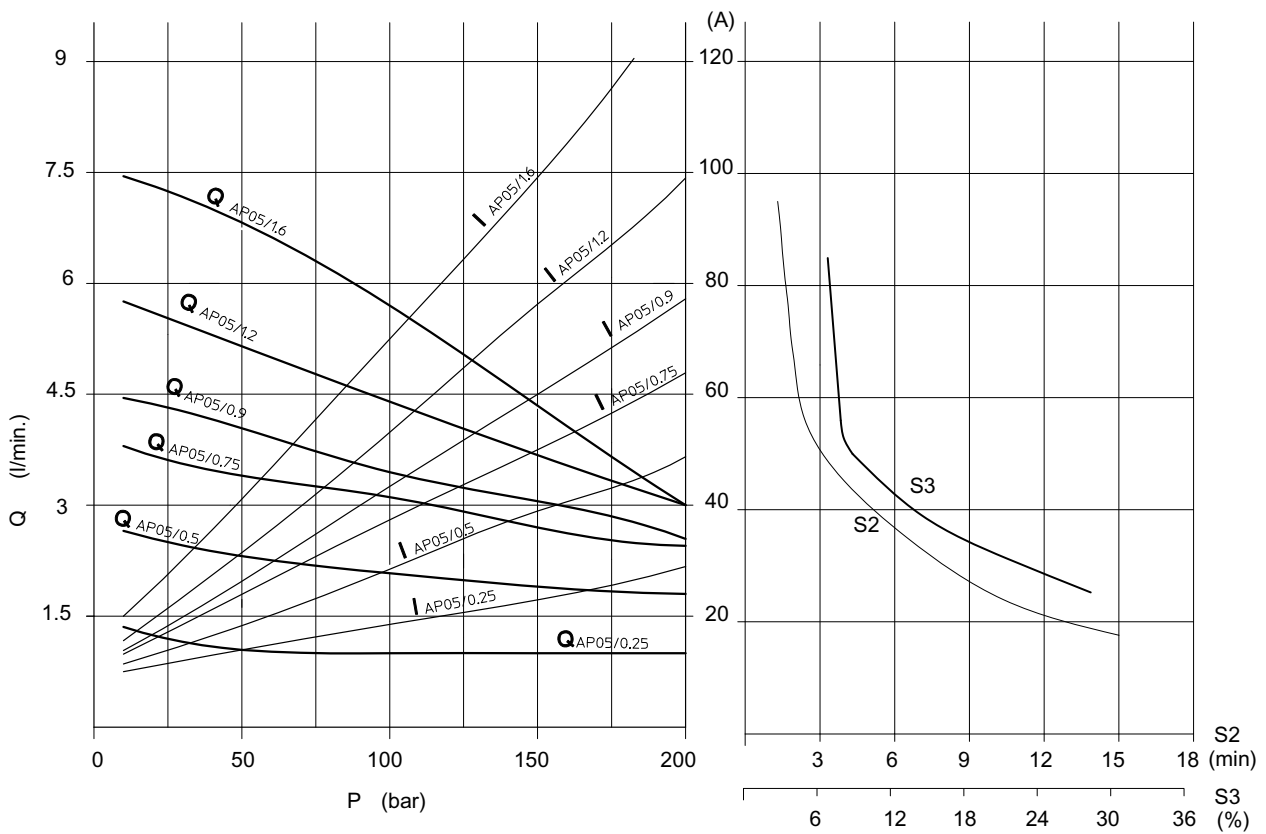

Voltage	Nominal Power
12 V	1600 W
24 V	2200 W

Protection index: ..... IP44  
 Insulation class: ..... F  
 Type of winding: ..... Compound  
 Brushes kit: BK01 ..... (12/1600) 200544138022  
 BK02 ..... (24/2200) 200544138023  
 Minimum brushes length: ..... 12.5 mm (0.5 inches)

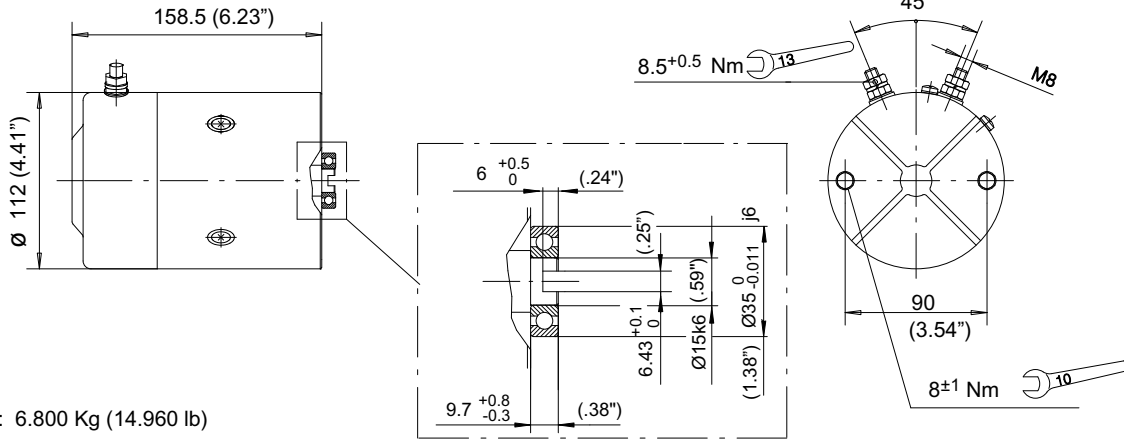

Weight: 6.800 Kg (14.960 lb)

Rotation Right	Motor		Motor with relay		Motor with thermal switch	
	12V-1600W	24V-2200W	12V-1600W	24V-2200W	12V-1600W	24V-2200W
Type	C135AB/H0	C240AB/S0	C135AB/H0 +R109	C240AB/S0 +R215	C135AB/HT	C240AB/ST
Code	200543913706	200543924007	200763310240	200763320330	200543913502	200543924008
Relay			Standard			
Relay type			R109	R215		

Motor mounting positions

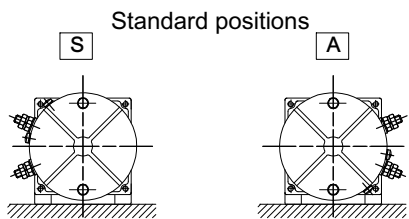

Standard positions

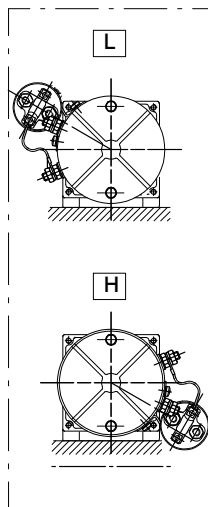

Relay mounting positions

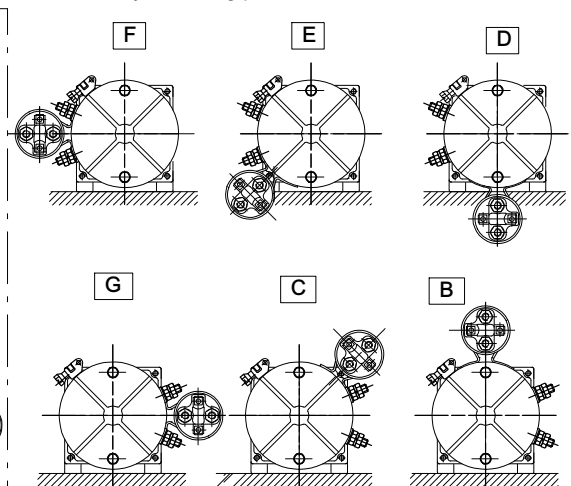

Electric motor										Pos.
5	C	1	3	5	A	B	/	H	1	S
Relay										Pos.
R	1	0	9							L

Example

## 12 V - 1600 W

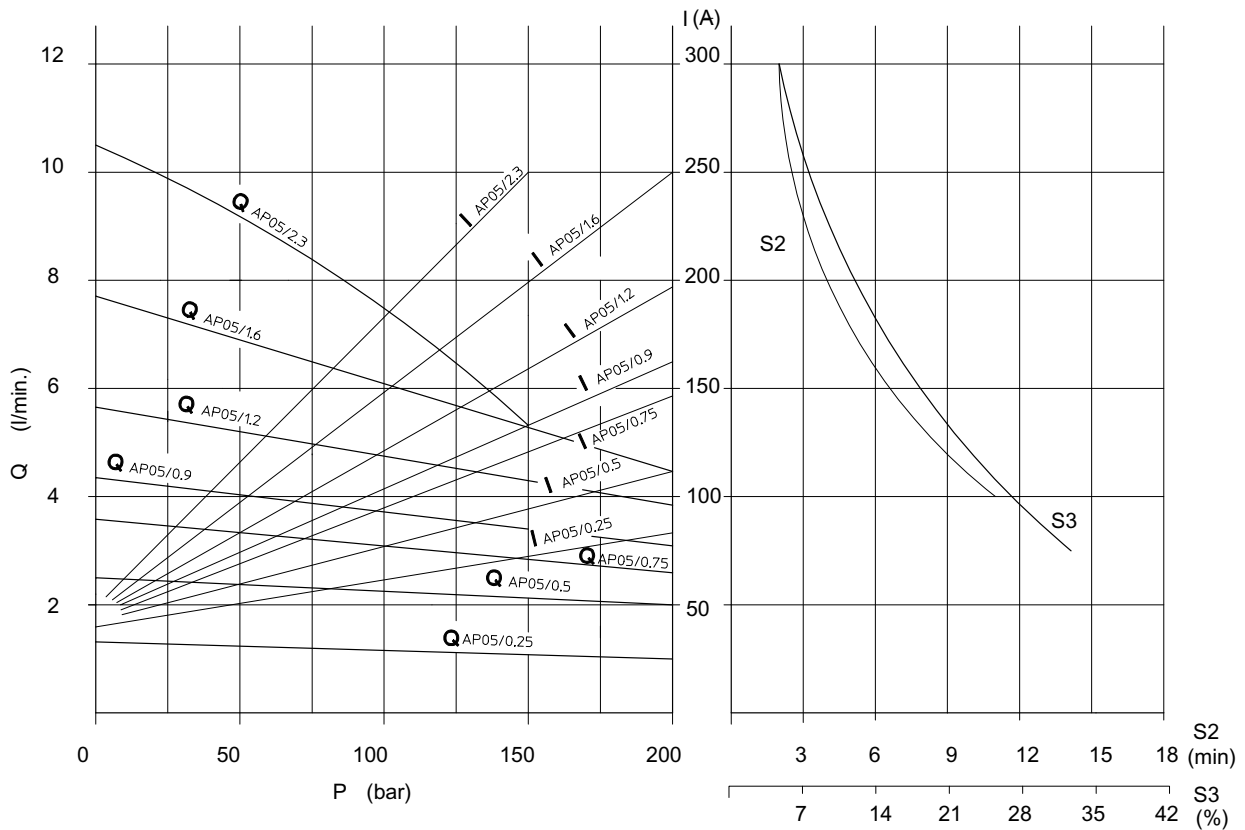

## 24 V - 2200 W

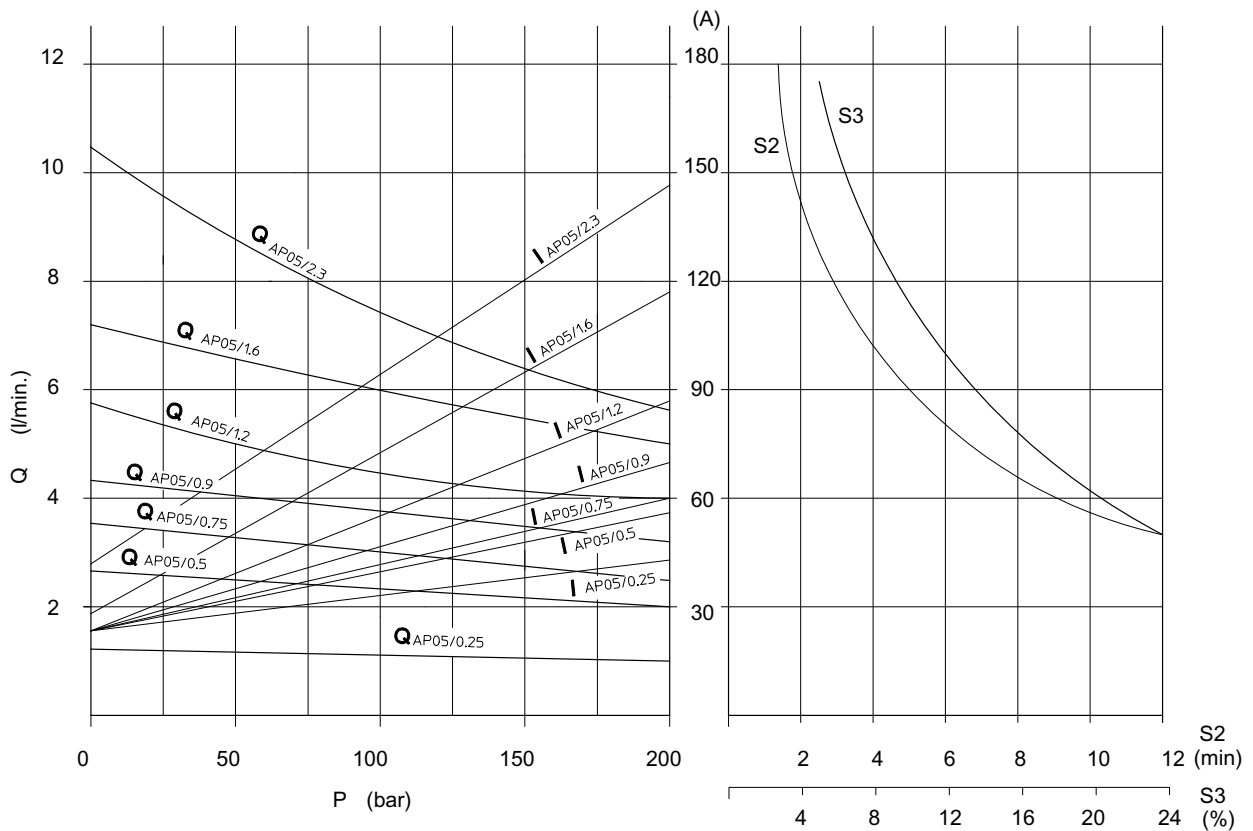

Voltage	Nominal Power
12 V	1500 W
24 V	2000 W

Protection index: ..... IP54  
 Insulation class: ..... F  
 Type of winding: ..... Compound  
 Brushes kit: BK03 ..... (12/1500) 200544138016  
                   BK04 ..... (24/2000) 200544138015  
 Minimum brushes length: ..... 12.5 mm (0.5 inches)

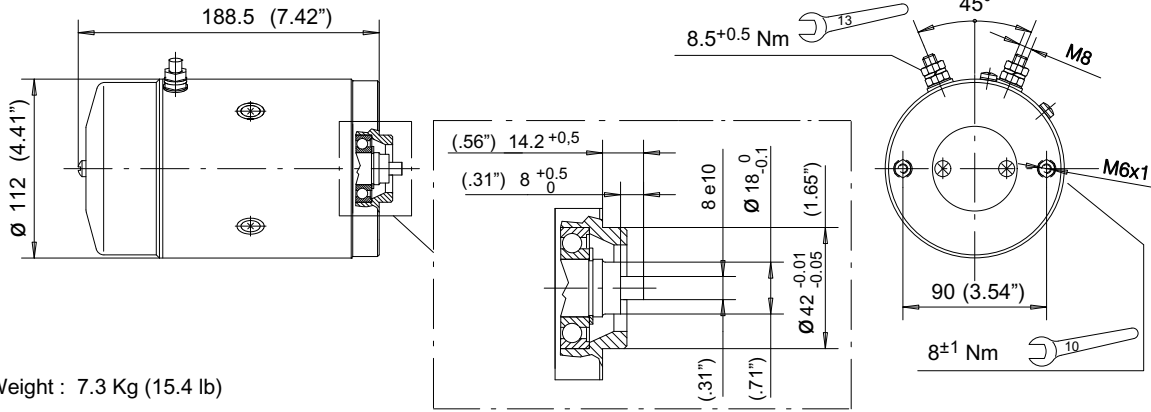

Weight : 7.3 Kg (15.4 lb)

Rotation Right	Motor		Motor with relay		Image
Type	12V-1500W C134AK/O0	24V-2000W C238AK/P0	12V-1500W C134AK/O0 + R109	24V-2000W C238AK/P0 + R215	
Code	200543913416	200543923813	200763310260	200763320250	
Relay			Standard		
Relay type			R109	R215	

Motor mounting positions

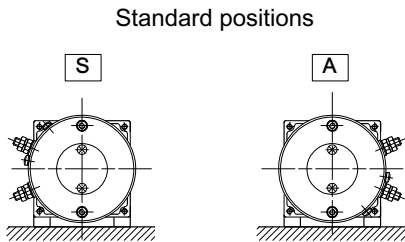

Standard positions

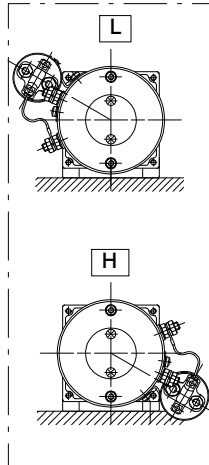

Relay mounting positions

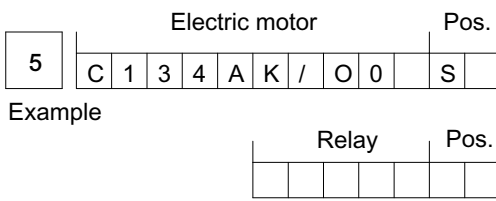
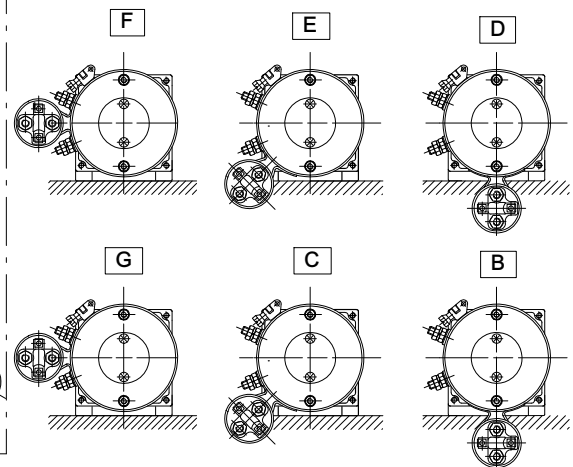

## 12 V - 1500 W

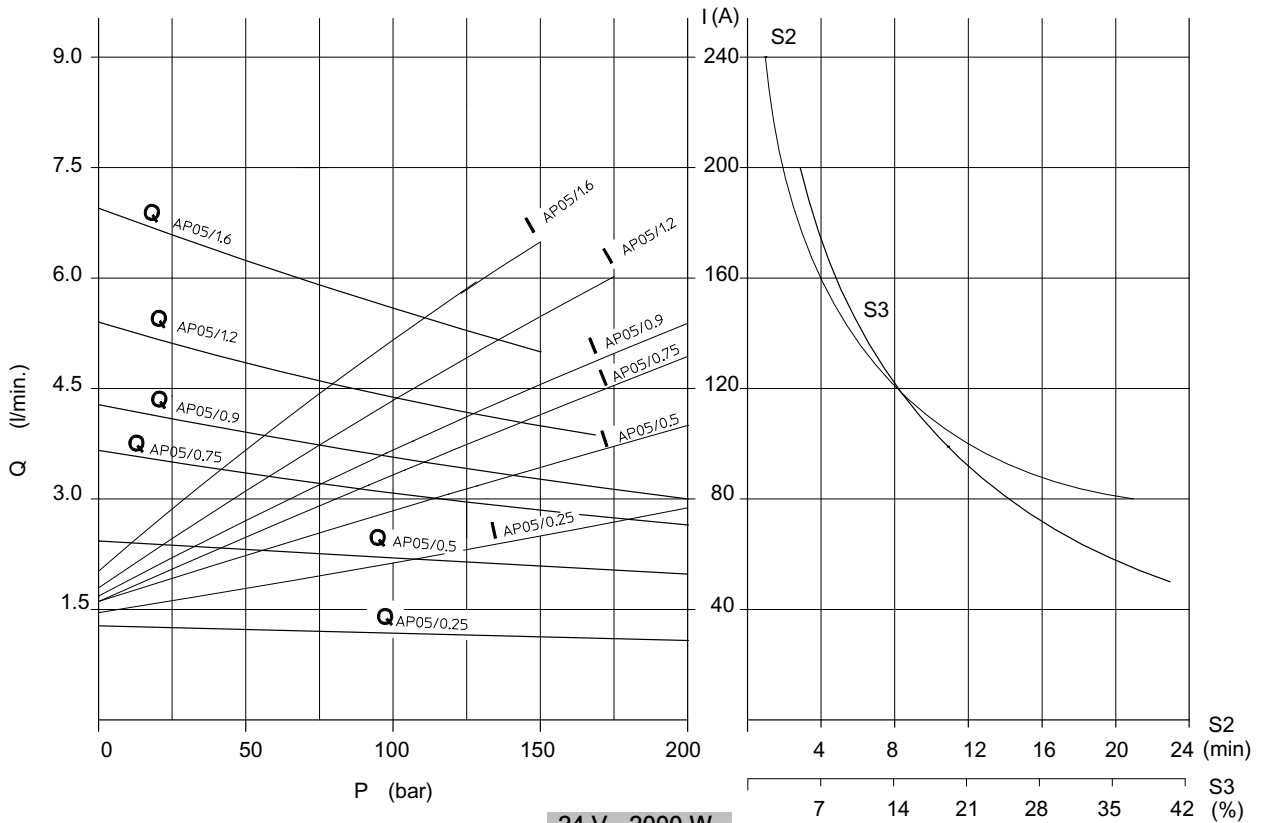

## 24 V - 2000 W

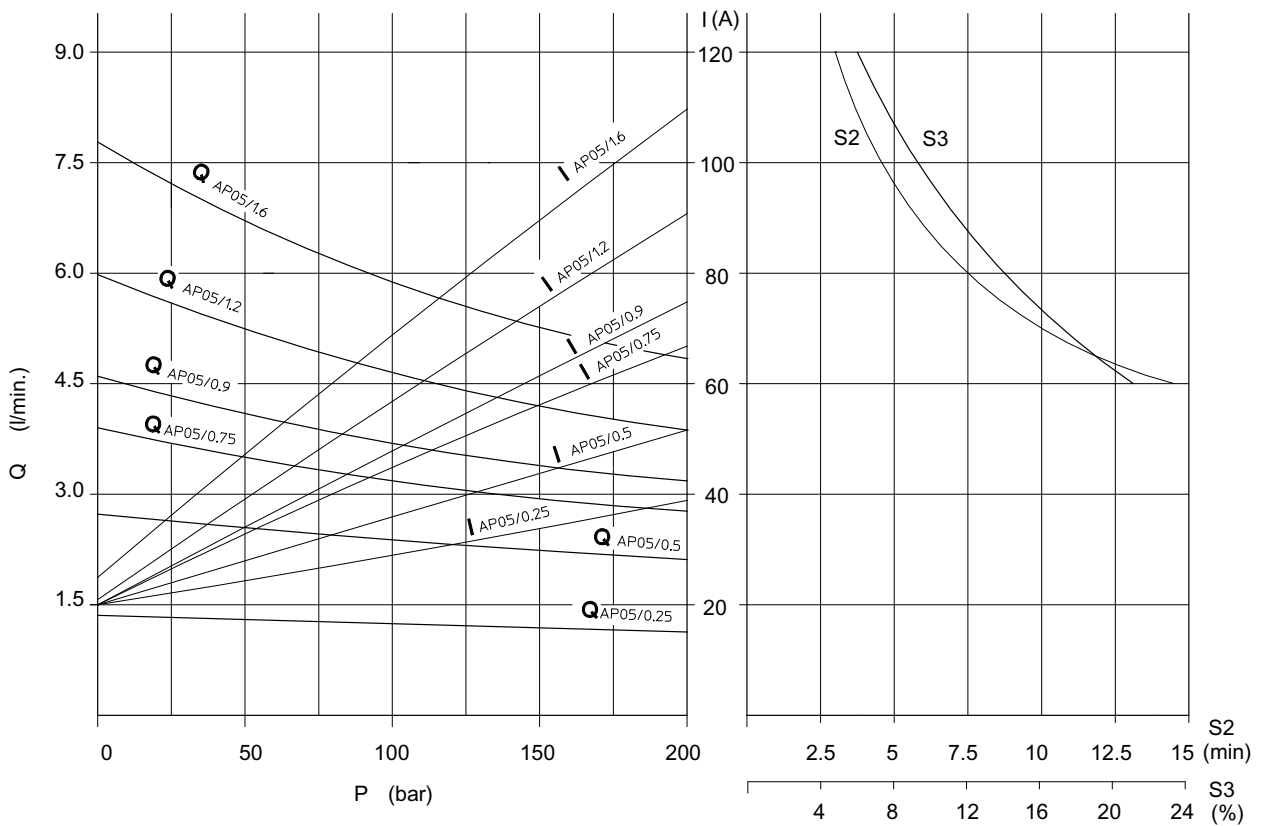

Voltage	Nominal Power
48 V	2000 W

Protection index: ..... IP54  
 Insulation class: ..... F  
 Type of winding: ..... Compound  
 Brushes kit: **BK05** ..... 200544138018  
 Minimum brushes length: ..... 12.5 mm (0.5 inches)

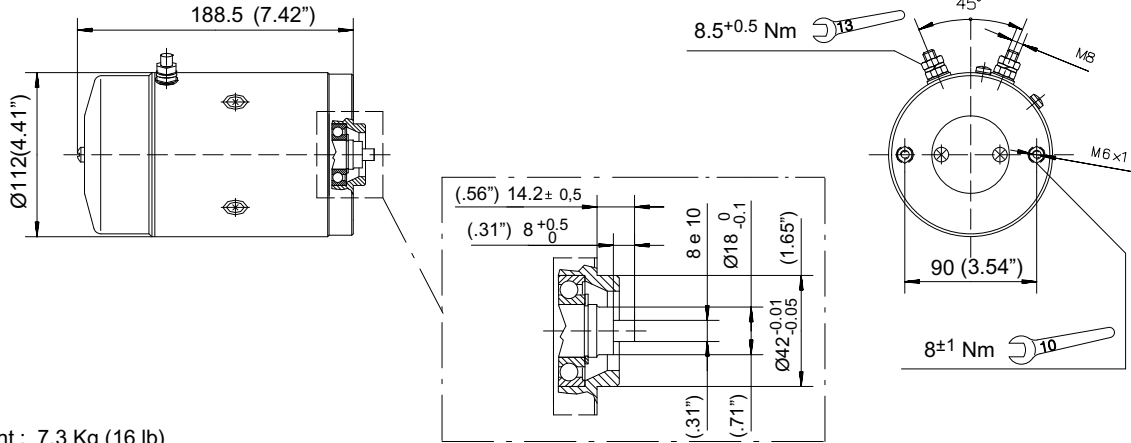

Weight : 7.3 Kg (16 lb)

	Motor	Motor with relay	
Rotation Right			
Type	T82K		
Code	200543933803		
Relay			
Relay type			
	48 V - 2000 W		

### Motor mounting positions

#### Standard positions

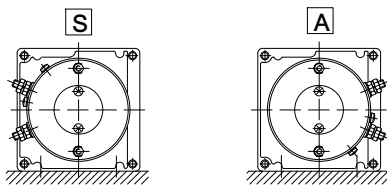

5	Electric motor				Pos.
	T	8	2	K	S

Example

Relay	Pos.

48 V - 2000 W

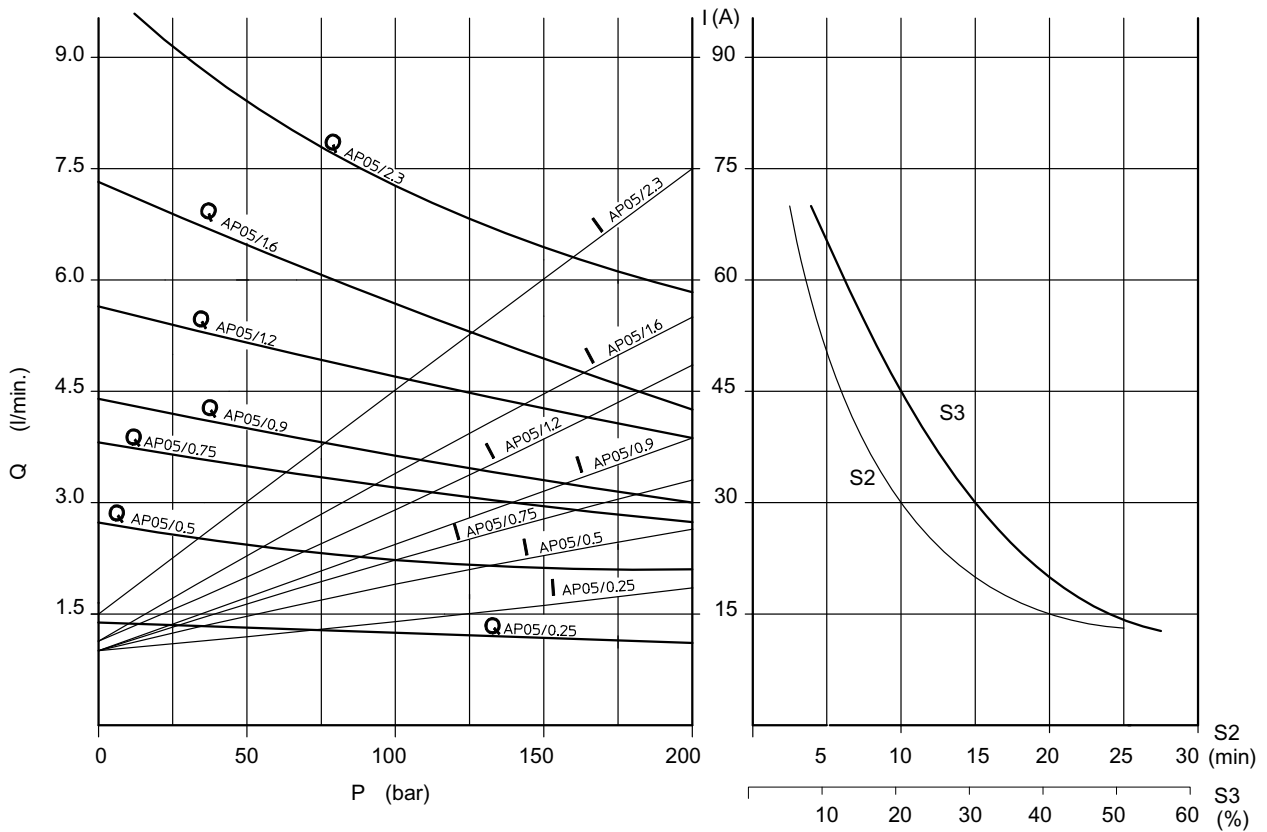

## 5.2 A.C. Motors

### 5.2.1 Technical information

#### Versions:

Electric motors supplied by Bucher Hydraulics S.p.A. respond to European Standard EN60034-1 (IEC-3, CEI2-3, VDE 0530T1).

Available power ratings: 0.25 ÷ 4 kW

Single phase motor: 230V ±5% - 50 Hz

Three phase motor: 230/400V ±10% - 50 Hz

European standard IEC38 (1983) envisages the unification of supply voltages, adopting 230 V for single phase and 400 V for three phase. Motors responding to this standard are available only by request: consult our Bucher Hydraulics.

#### Protection factor

Standard electric motors are specified:

Protection degree: IP54 (IP55 on request)

Insulation class: F (max 105°).

#### Type of duty

All motors can be supplied rated for continuous duty S1 or intermittent duty S3<80%.

With respect to the European Standard IEC 60034-30:2008 all motors rated for continuous duty S1, will be manufactured according to IE2 Efficiency class

#### Efficiency class:

All motors respond to European standard IEC 60034-30:2008. This means all the motors between 0,75 kW and 375 kW both 2 and 4 poles, rated for continuous duty S1 or intermittent duty S3≥ 80%, are in IE2 Efficiency class.

#### Speed of rotation

The nominal speed of rotation for A.C. motors is calculated by the following formula:  $n = (60 \cdot f) / P$

f= frequency (50 Hz for EU / 60 Hz for USA)

P= pair of poles

A 4 poles motor has 1500 rev/min as nominal speed

#### Pole number:

Indicated motors are 4 pole type, but Bucher Hydraulics S.p.A. can supply 2 pole motors too.

Please ask Bucher Hydraulics.

#### Size

The size designation gives the main dimensions for the standard electric motors: shaft dimensions, type of flange, max diameter, etc. A specific table shows the essential dimensions corresponding to each standard size.

The electric motors with direct flange have their own dimensions especially the front flange.

#### Frame size

Standard option:

Standard motors have B34 frame so mounting flange with spigot, tapped fixing holes and motor fixing feet.

B14 frame is also available on request (as B34 but without motor fixing feet).

Direct flange motors are delivered without fixing feet (B14 style).

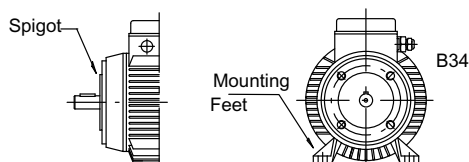

#### Ventilation:

All the motors (standard and direct flange) can be available with or without ventilation. Normally the direct flange motors are delivered without ventilation.

Important to say that motors without ventilation can not be rate for continuous duty S1.

#### Starting single phase motors

Standard single phase motors have a permanently connected run capacitor. Where starts are made on-load or in especially heavy-duty condition, requiring a starting torque higher than the nominal torque, single phase induction motors can be supplied, by request, with a dual capacitor arrangement: a start capacitor, disconnected by an automatic cutout once the motor is up to speed, and a permanently connected run capacitor, or hydraulic circuit with decompression valve assembled on the pump.

Please consult Bucher Hydraulics.

#### Electrical diagrams

The following illustration shows a number of connection diagrams for single phase and three phase electric motors. The terminal boxes used for these motors respond to NFC 51-120 (IEC34-8) and have 6 power terminals.

A terminal is also provided for the earth wire, which must always be connected

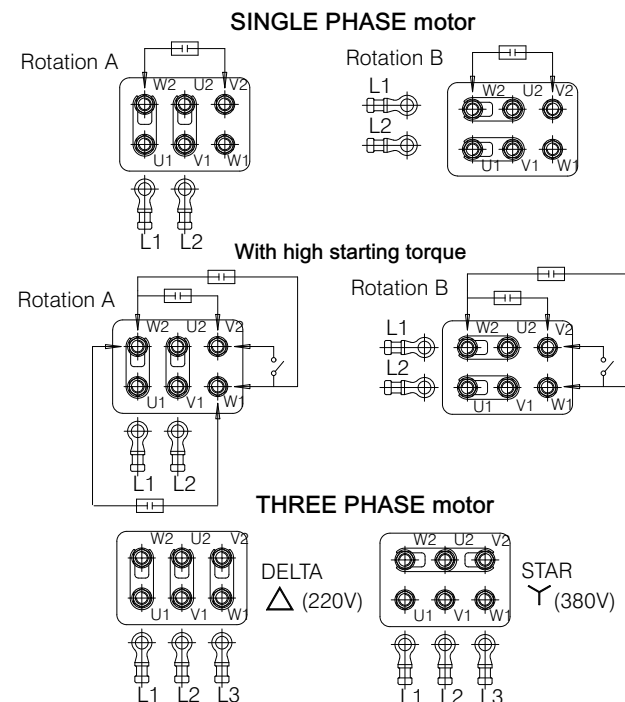

Three phase motors: with terminals U1-V1-W1 connected respectively to phases L1-L2-L3 of supply, the motor will rotate clockwise (as viewed from the shaft end).

Bucher Hydraulics S.p.A. is not an electric motors manufacturer so these components come from third part. Bucher Hydraulics S.p.A. reserves the right to change the motor supplier without notice whenever considers it necessary. Minor dimensional and cosmetic differences may exist.

5.2.2 Standard interface (flange/drive needed)

Frame size

**B14**

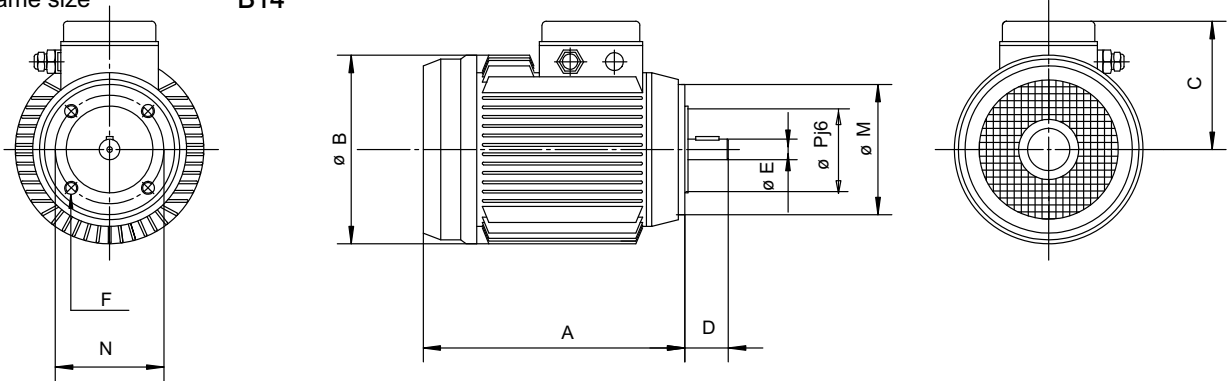

Frame size

**B34**

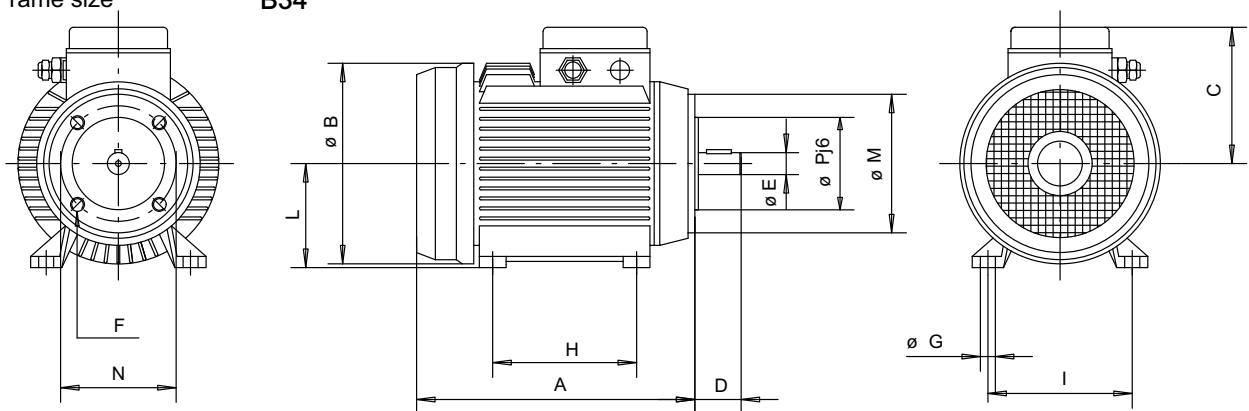

Size	Dimensions													
	Units	A	B	C	D	E	F	G	H	I	L	M	N	P
63	mm	189	124	104	23	11	M5	7	80	100	63	90	75	60
	inch	7.44	4.88	4.09	.90	.43		.28	3.14	3.93	2.48	3.54	2.95	2.36
71	mm	218	140	109	30	14	M6	7	90	112	71	105	85	70
	inch	8.58	5.51	4.29	1.18	0.55		0.27	3.54	4.41	2.79	4.13	3.35	2.76
80	mm	237	156	123	40	19	M6	9	100	125	80	120	100	80
	inch	9.33	6.14	4.84	1.57	0.75		0.35	3.94	4.92	3.15	4.72	3.94	3.15

5.2.3 Standard interface 4 pole - 50 Hz - 230 V

Frame size B14 SINGLE PHASE motor				
Power		Size	Type	Code
kW	HP			
0.12	0.16	63	T211	200543160411
0.18	0.25	63	T212	200543160811
0.25	0.33	71	T209	200543161221
0.37	0.5	71	T201	200543161823
0.55	0.75	80	T202	200543162231
0.75	1	80	T203	200543162631

Frame size B34 SINGLE PHASE motor				
Power		Size	Type	Code
kW	HP			
0.12	0.16	63	T711	200543160412
0.18	0.25	63	T712	200543160812
0.25	0.33	71	T709	200543161223
0.37	0.5	71	T701	200543161822
0.55	0.75	80	T702	200543162233
0.75	1	80	T703	200543162633

## 5.2.4 Standard interface 4 pole - 50 Hz - S1 - 230/400 V

Frame size B14 THREE PHASE motor					
	Power		Size	Type	Code
	kW	HP			
	0.12	0.16	63	T011	200543560411
	0.18	0.25	63	T012	200543561041
	0.25	0.33	71	T009	200543561221
	0.37	0.5	71	T001	200543561821
	0.55	0.75	80	T002	200543562231

Frame size B34 THREE PHASE motor					
	Power		Size	Type	Code
	kW	HP			
	0.12	0.16	63	T511	200543560442
	0.18	0.25	63	T512	200543561011
	0.25	0.33	71	T509	200543561222
	0.37	0.5	71	T501	200543561824
	0.55	0.75	80	T502	200543562232

## 5.2.5 Standard interface 4 pole - 50 Hz - S3=70% - 230/400 V

Frame size B14 THREE PHASE				
Power		Size	Type	Code
kW	HP			
0.75	1	80	T003	200543562631

Frame size B34 THREE PHASE				
Power		Size	Type	Code
kW	HP			
0.75	1	80	T503	200543562632

## 5.2.6 Mounting position

Standard position

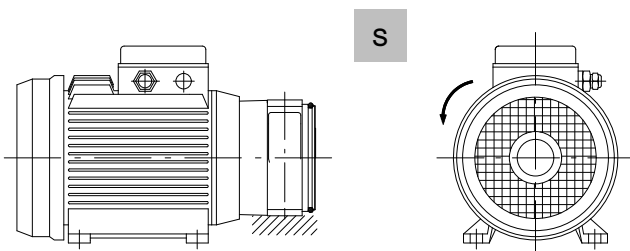

Reversal position

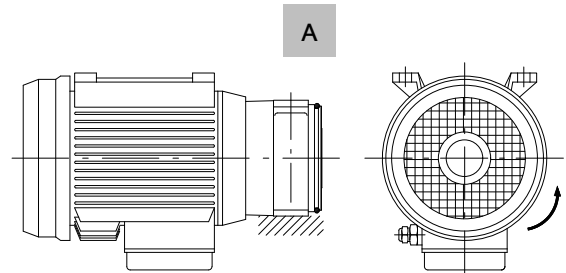

Left lateral

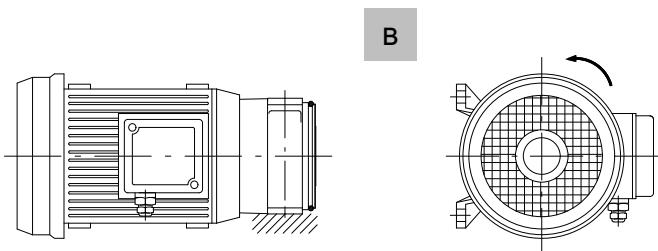

Right lateral

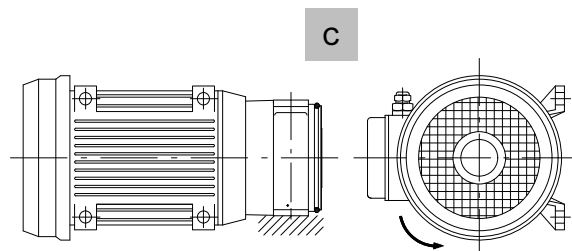

Example	Electric motor	Pos
5	T 5 0 3	S

Relay	Pos

N.B.: Looking at the fan side the e. motor must rotate counterclockwise

## 6 Drives

### 6.1 Introduction

The drives illustrated in this chapter are intended for use in conjunction with D.C. and A.C. motors as described in the previous chapter.

To allow the use of different motors, the interface on the motor side is shown with the dimensions of the spigot and of the end of the pump drive shaft.

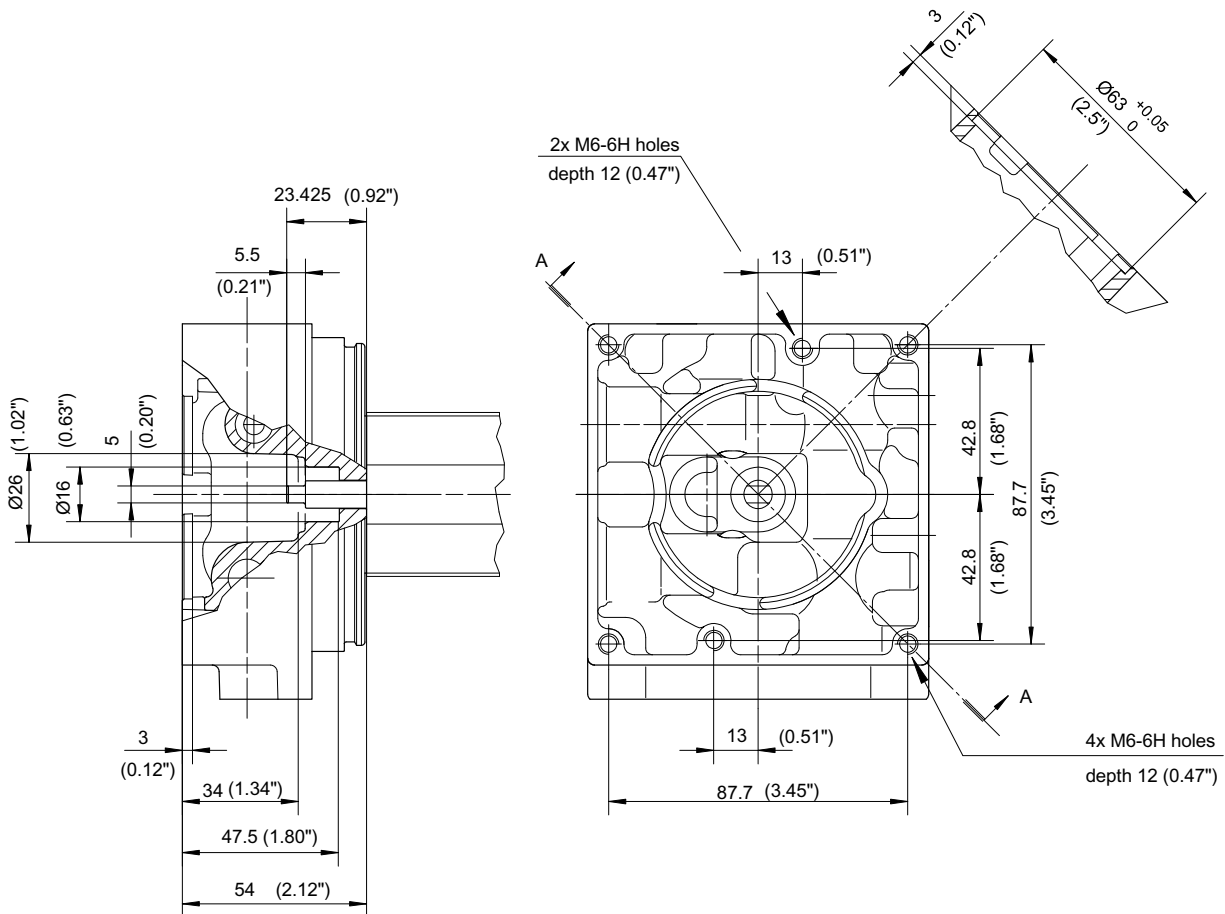

### 6.2 Materials

The flanges for connection of the power pack housing and electric motor are in aluminium alloy.

Couplings are high strength steel, with mating surfaces hardened by heat treatment for added resistance to wear.

### 6.3 Drives for D.C. motors

The tables allow selection to select the correct drive in function of the selected motor.

Motor type		Voltage	Power	Type
C120PD/C0		12 V	500W	E61
C220PD/C0		24 V	500W	
C128PK/A0	C134AK/O0 + R109	12 V	800W	
C228PK/A0	C228PK/A0 + R215	24 V	800W	
C134AK/O0	C134AK/O0 + R109	12 V	1500W	E65
C238AK/P0	C238AK/P0 + R215	24 V	2000 W	
T82K		48 V	2000 W	
C135AB/H0	C135AB/H0 + R109	12 V	1600W	E66
C240AB/S0	C240AB/S0 + R215	24 V	2200 W	

### 6.4 Drives for A.C. motors

#### 6.4.1 Single phase

Motor type	Power		Size	Drive
	kW	HP		
T211-T711	0.12	0.16	63	E30
T212-T712	0.18	0.25		
T209-T709	0.25	0.33	71	E33
T201-T701	0.37	0.5		
T202-T702	0.55	0.75	80	E31
T203-T703	0.75	1		

#### 6.4.2 Three phase

Motor type	Power		Size	Drive
	kW	HP		
T011-T511	0.12	0.16	63	E30
T012-T512	0.18	0.25		
T009-T509	0.25	0.33	71	E33
T001-T501	0.37	0.5		
T002-T502	0.55	0.75	80	E31
T003-T503	0.75	1		



**6.8 Drive E30**

Code E30 200960400040

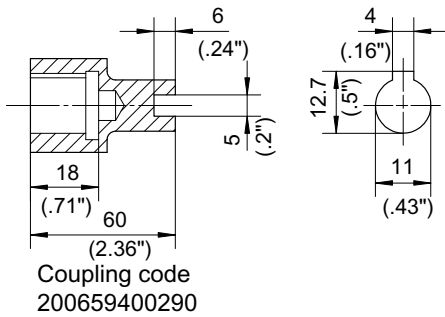

Coupling code  
200659400290

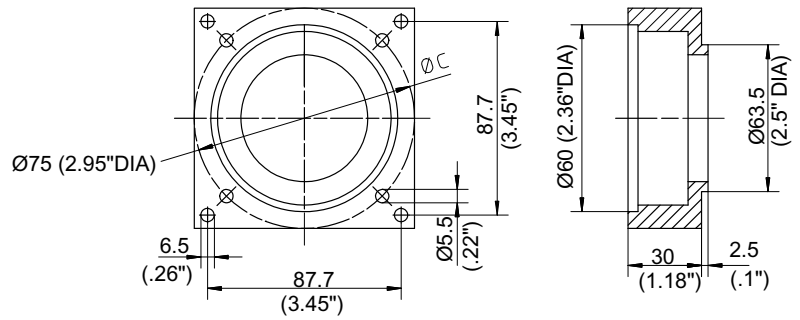

**6.9 Drive E31**

Code E31 200960400050

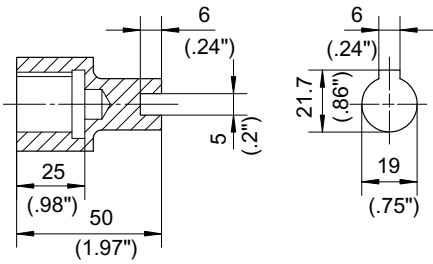

Coupling code  
200659400310

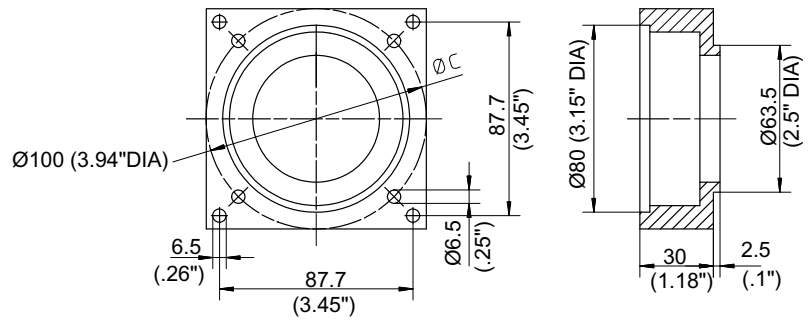

**6.10 Drive E33**

Code E33 200960400060

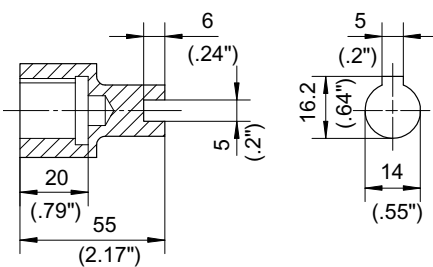

Coupling code  
200659400300

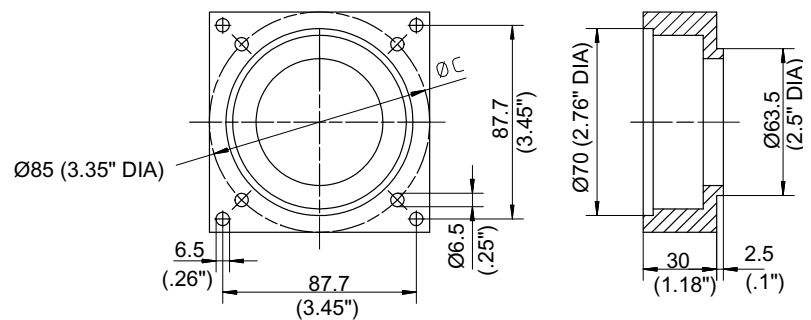

## 7 Cartridge valves

### 7.1 Introduction

This chapter includes all technical information relating to valves for use in conjunction with the housings described in section 1.

Complete the designation codes for the selected valves ac-

7	Cavity <span style="border: 1px solid black; padding: 0 2px;">a</span>															Cavity <span style="border: 1px solid black; padding: 0 2px;">b</span>														
																S	D	F	8	1	7	/	2	2	-	T	H	-	2	7
	Cavity <span style="border: 1px solid black; padding: 0 2px;">e</span>																													
	1	5	V	M	0	1																								
Hand lever					Stick lever					Volt																				
										2					3															

#### 7.1.1 Materials

Bucher Hydraulics cartridge valves are manufactured using steel of high mechanical strength. Friction and potential wear are minimized by special heat treatments. Surface heat treatments protect parts exposed to the external environment. Standard seals are NBR (Buna N), with backup ring in PTFE. For application requiring special compound FPM (Viton) etc. consult Bucher Hydraulics.

#### 7.1.2 Indication for use

Use mineral oil based hydraulic fluids to ISO/DIN standard, only. Recommended viscosity range: 20-120 mm<sup>2</sup>/s (cSt) maximum viscosity 700 mm<sup>2</sup>/s (cSt).

For different fluids and operating conditions, consult our Sales Dpt.

All valves showed in the present catalogue are marked with correct flow direction, please observe it always. Valves must never be tampered with or modified.

Any unwarranted interference may adversely affect the safety and correct operation of the entire system.

Seals and backup rings are user-serviceable.

The appropriate replacement kit is indicated for each valve. Before installing a valve in its cavity, ensure that the housing and all components of the system are clean.

Smear external seals lightly with grease, and check that any filters installed are correctly positioned.

Tighten the valve to the specified torque setting.

#### 7.1.3 General technical information

All valves with leakage-free operating characteristic are 100% factory tested.

Nonetheless, the guaranteed maximum leakage may be exceeded if the valve is installed in a system with inadequate filtration.

Pressure drops and general performance indicated in the catalogue are referred exclusively to the component.

In the case of valves subject to adjustable setting, such as the pressure relief and if not specified in the order, we set them according to standard setting values indicated at section 7.2.1 .

ording to the technical information and guidelines given for each component. Illustrated here by way of example is a correct and complete compilation for section 7 of the hydraulic power pack designation form.

#### 7.1.4 Solenoid valves

The correct selection of the solenoid valve is related to the maximum flow rate and operating pressure values.

In a system with a single acting cylinder, therefore, it must be considered that the effective rate of flow through the unloading solenoid valve is not the flow delivered by the pump, but rather the momentary flow exhausted from the cylinder, or the restricted flow needing a pressure-compensated flow control valve, if installed.

The nominal voltage is the value indicated on the solenoid.

Effective voltage must be measured at the terminals of the solenoid connector.

A maximum allowed tolerance of ±10% in relation to the nominal value is accepted.

Incorrectly power supply components and cables (which length has to be as shorter as possible) and/or low battery charge can cause not correct solenoid valve operation.

Standard solenoids valves are designed for D.C. operation. A.C. supply requires a connector with bridge rectifier included. When energized with A.C. voltage, the solenoids can operate at 50 or 60 Hz frequency, without distinction. The connection used for standard solenoids are to EN 175301-803 (DIN 43650).

Solenoid with different connections (Amp JuniorTimer, Direct Wiring, etc.) can be supplied on request, after agreement with Bucher Hydraulics.

The solenoid can be rotated through 360°, and the connector EN 175301-803 (DIN 43650) positioned at 90° intervals.

Specified performance datas were recorded in stabilized solenoid operated temperature and voltage at the -10% of the nominal value.

All solenoid valves are fitted with protective O-rings installed between the tube and the solenoid.

This protects internal parts from condensation and contaminants, which could cause malfunction.

Standard solenoids are not suitable for operation in environments where there is any risk of explosion (see Directives and standards)

## 7.1.5 General notes on D.C. power input

A swift and secure coupling is obtained using the special connector (type 200544110009).

The cable coming from the D.C. power source (batteries, rectified a.c. main supply, etc.) must be connected as indicated in the diagram (figure 1).

The negative and positive polarity of the wire need not be verified for connection purposes. The connector incorporates a terminal for earthing the solenoid.

It is important to check that the grommet and armour clamp nut are correctly assembled (figure 2), as this prevents the cable being wrenched from connector.

Fig. 1

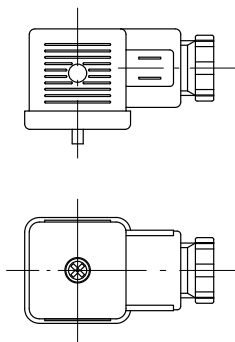
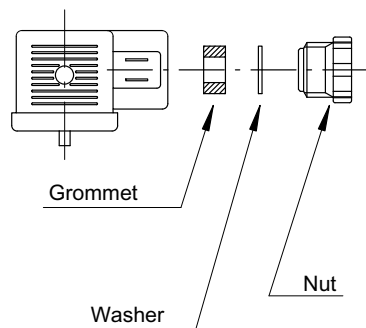
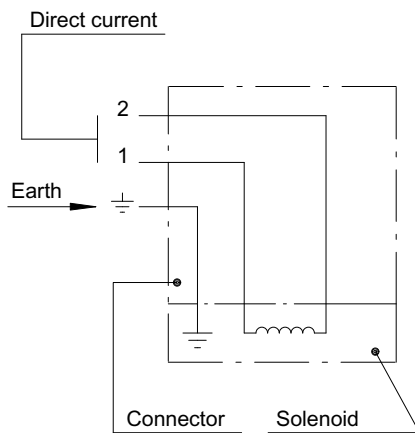

Fig. 2



## 7.1.6 General notes on A.C. power input

Solenoid valves can be operated off the A.C. mains supply using a special connector (type 200544110012) which converts the current to provide the D.C. input required by the solenoid.

The connector in question is identified by a symbol (figure 3) marked both on the top and on the bottom face.

The conversion from alternate to direct current is effected by a rectifier circuit comprising a four-diode bridge, and a voltage-dependent resistor (figure 4) protecting against over voltages in the power supply circuit.

Accordingly, the solenoid are designed to operate correctly only when connected to a diode bridge which reduces the input voltage by 10%.

The earth connection is made by way of the terminal provided.

Fig. 3

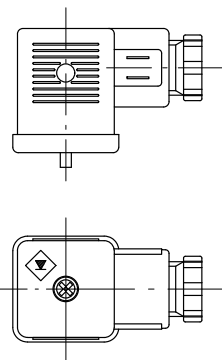

Rectifier symbol

Alternative current (A.C.)

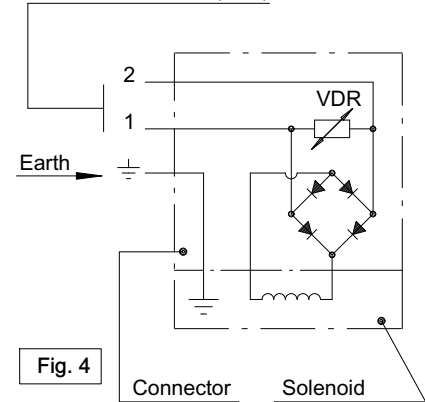
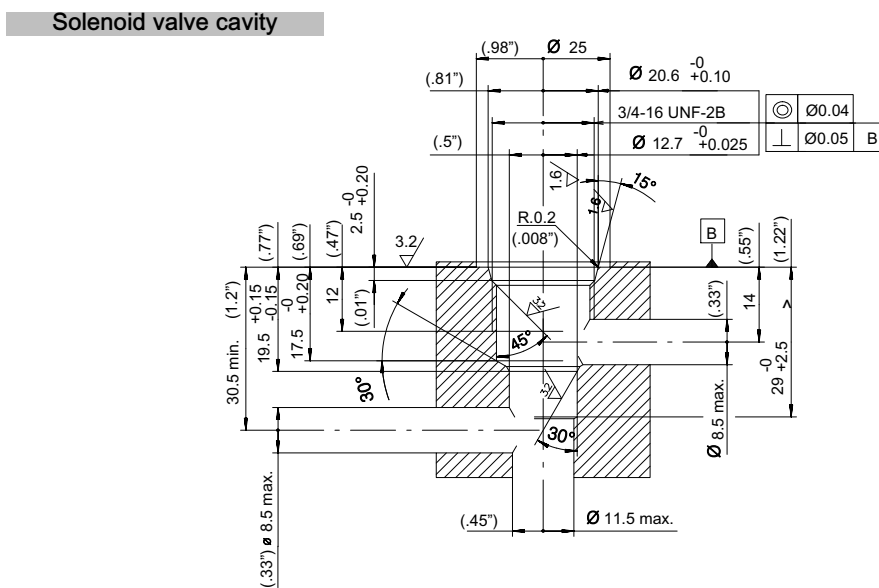
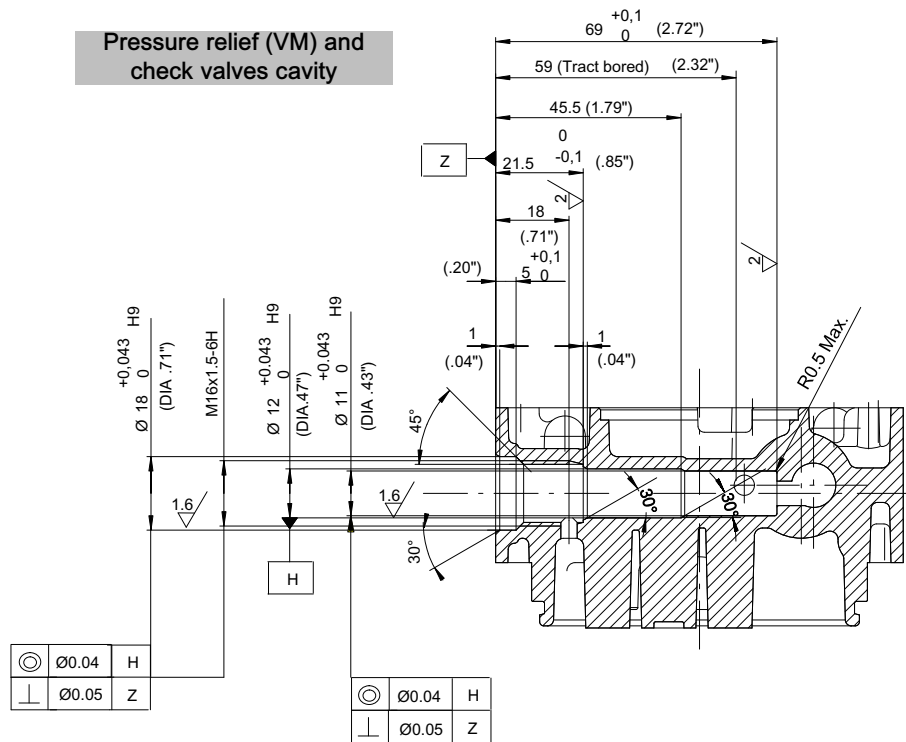

Fig. 4

For users wishing to make up special circuits and blocks with Bucher Hydraulics S.p.A. cartridge valves, it is import-

ant to observe the indications given below when machining the valve cavities.



## 7.2 Pressure relief valves

### 7.2.1 Pressure relief valve: \*\*VM01

Direct acting  
Balanced piston  
Adjustable setting  
Three setting ranges

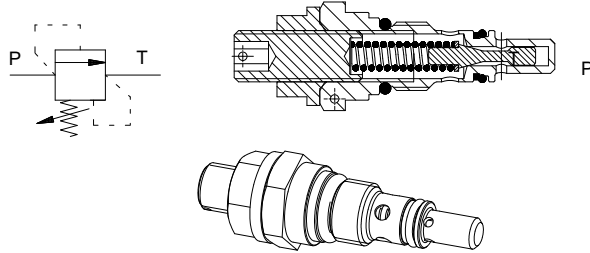
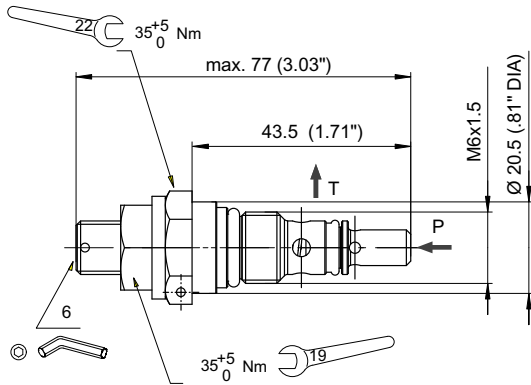

The valve can be sealed against tampering.

Option: sheath shrink temperature: T=60°  
CAP02 code 200660200031

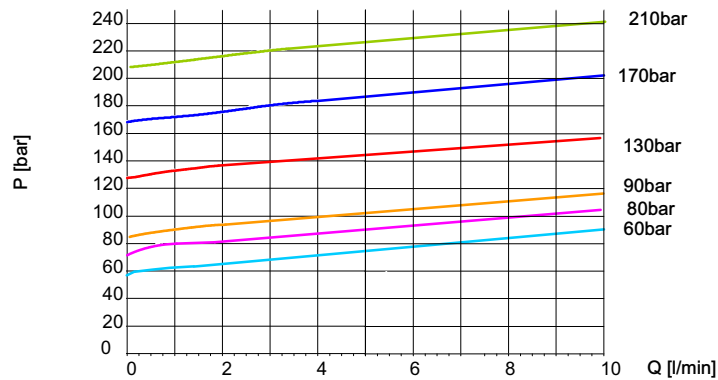

The purpose of a relief valve is to keep the maximum system pressure at a safe level. When the hydraulic power unit is supplied with pressure relief valves, the correct calibration is provided by Bucher Hydraulics S.p.A. and there are no reasons to change this value.

When ordering, state in full the sheath part number, and, if the valve is to be supplied with sheath already fitted, the relief pressure setting required.

\*\*\* Maximum admitted pressure value: 210 bar when used into the diecast aluminium alloy body

#### Pressure setting

For present values other than those indicated, replace the first two digits of the designation with the setting required. For example, required setting 130 bar: designation type 13VM01. Always check that the required value falls within the standard ranges of adjustment

Performances	
Max. Flow rate	7 l/min.
Max. Pressure	210 bar
Weight	0.0852 kg
Oil viscosity	12 to 400 cSt
Oil temperature	-20 to 100 °C
Recommended filtration	21/19/16 (10 NAS 1638)

Spring	Setting range	Standard setting	Type	Code
00	Plug	No valve	00VC00	200778400200
03	5 - 40 bar	30 bar	03VM01	200787400840
06	45 - 80 bar	60 bar	06VM01	200787400850
15	85 - 210 bar	150 bar	15VM01	200787400860

### 7.3 Solenoid operated directional valves

Circuit	Solenoid	Override	Type	Power	Description	Page	
Normally closed	On-Off	Without manual override			Standard version		
			Piloted	standard (16 Watt)	<b>SPD817/22-TV</b>	Page 52	
	Direct acting		heavy duty (27 Watt)	SDF817/22-TH	Page 53		
			With manual override				
			Piloted	standard (27 Watt)	SPFE817/22-TV	Page 54	
			Direct acting	heavy duty (27 Watt)	SDFE817/22-TH	Page 53	
	Proportional						
			Without manual override				
		Piloted	standard (26 Watt)	PPF817/TV-03	Page 58		
Normally open	On-Off	Without manual override			Standard version		
			Piloted	standard (27 Watt)	<b>SPF817/22-TOV</b>	Page 55	
			With manual override				
			Piloted	standard (27 Watt)	SPFE817/22-TOV	Page 55	

## 7.3.1 Solenoid operated directional valve: SPD817/22-TV

Normally closed  
Piloted - 16 W  
Poppet type  
Flow from 1 to 2

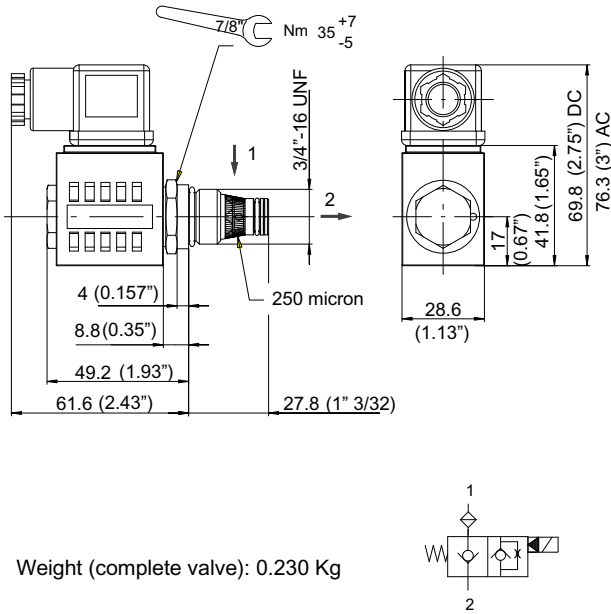

Weight (complete valve): 0.230 Kg

Performances	
Max. pressure (***)	270 bar
Max. recommended pressure	See 2.2
Max. flow	20 l/min.
Rated power	16 Watt
Intermittence	ED= 100%
Voltage tolerance	± 10%
Internal leakage	0-5 drops/min.
Temperature range	-20/+90 °C
Connector type	DIN 43650
Time to open 12 V 20 l/min 80% of final change of state	16 ms.
Time to close 12 V - 20 l/min 80% of final change of state	18 ms.
O-Ring replacement kit	200974200480

\*\*\* = max.admitted pressure when used into power pack bodies: 230 bar

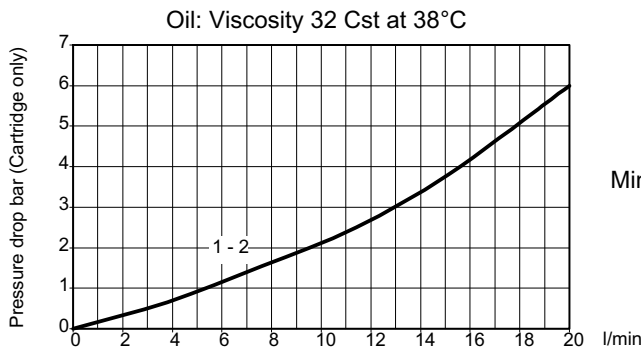

Minimum suggested working pressure = 5 bar

Directional valve without coil and connector

Type	Code*
SPD817/22-TV P.M.	200533910019

\* Mechanical part code only. For connector and coil see section: 7.3.5 - 7.3.6

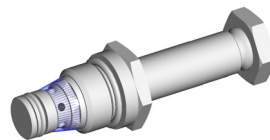

## 7.3.2 Solenoid operated directional valve: SDF817/22-TH - SDFE817/22-TH

Normally closed  
Poppet type  
Direct acting - 27 Watt  
Flow from 1 to 2  
With (SDFE) or without (SDF) manual override  
Manual override = push to open

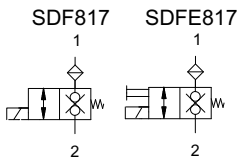
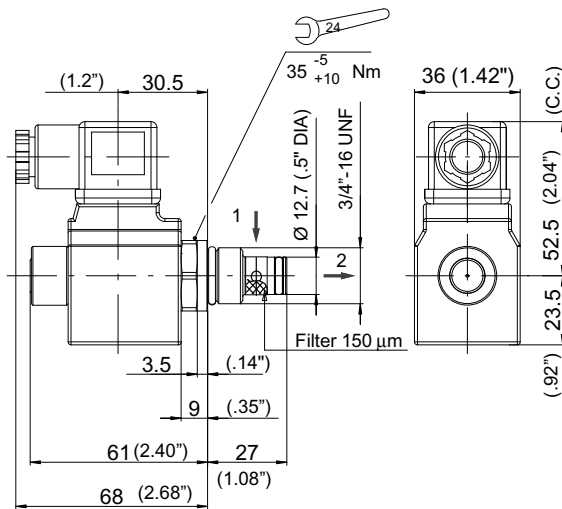

Weight (mechanical part only): 0.121 Kg

Performances	
Max. pressure	230 bar
Max. recommended pressure	See 2.2
Max. flow	15 l/min. 230 bar
Rated power	27 Watt
Intermittence	ED= 100%
Voltage tolerance	± 10%
Internal leakage	0-5 drops/min.
Temperature range	-20/+90 °C
Connector type	DIN 43650
Time to open (50-210 bar)	15-50 ms.
Time to close (50-210 bar)	10-50 ms.

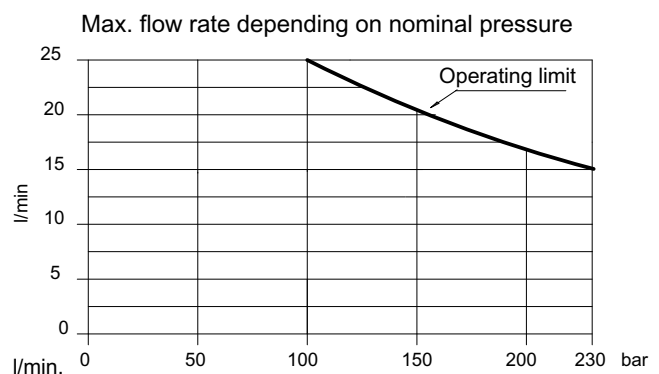
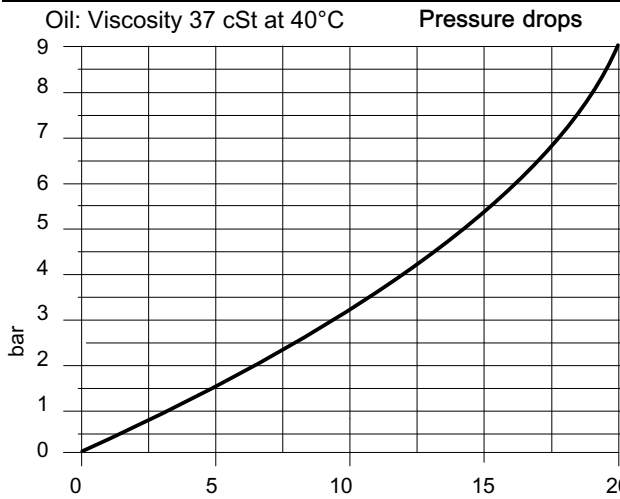

Type	Code*
ELVAL SDF817/22-TH P.M.	200757200940
ELVAL SDFE817/22-TH P.M.	200757200970

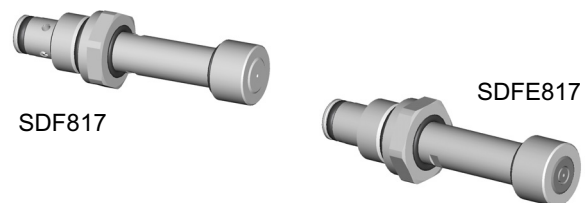

\* Mechanical part code only. For connector and coil see section: 7.3.5 - 7.3.6

## 7.3.3 Solenoid operated directional valve: SPFE817/22-TV

Normally closed  
Poppet type  
Piloted (27 W)  
Flow from 1 to 2  
With manual override (screw type)  
Manual override = unscrew to open

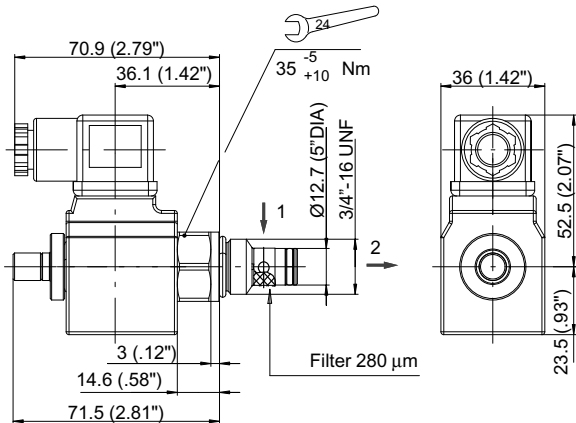

Performances	
Max. pressure (***)	350 bar
Max. recommended pressure	See 2.2
Max. flow	40 l/min.
Rated power	27 Watt
Intermittence	ED= 100%
Voltage tolerance	± 10% / -15%
Internal leakage	0.25 cm <sup>3</sup> /min.
Temperature range	-20/+90 °C
Connector type	DIN 43650
Time to open	<= 30 ms.
Time to close	<= 50 ms.

\*\*\* = max.admitted pressure when used into power pack bodies: 230 bar

Weight (mechanical part only): 0.118 Kg

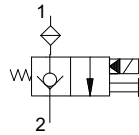

Oil: Viscosity 46 cSt at 40°C

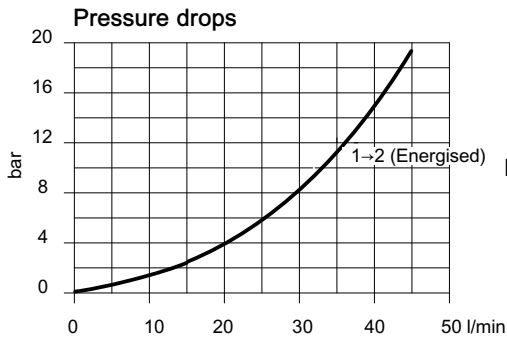

Minimum suggested working pressure = 5 bar

Type	Code*
ELVAL SPFE817/22-TV P.M.	200757200960

\* Mechanical part code only. For connector and coil see section: 7.3.5 - 7.3.6

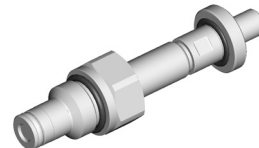

## 7.3.4 Solenoid operated directional valve: SPF817/22-TOV - SPFE817/22-TOV

Normally open  
Poppet type  
Piloted (27 W)  
Flow from 1 to 2  
With (SPFE) or without (SPF) manual override (pin type)  
Manual override = push to open

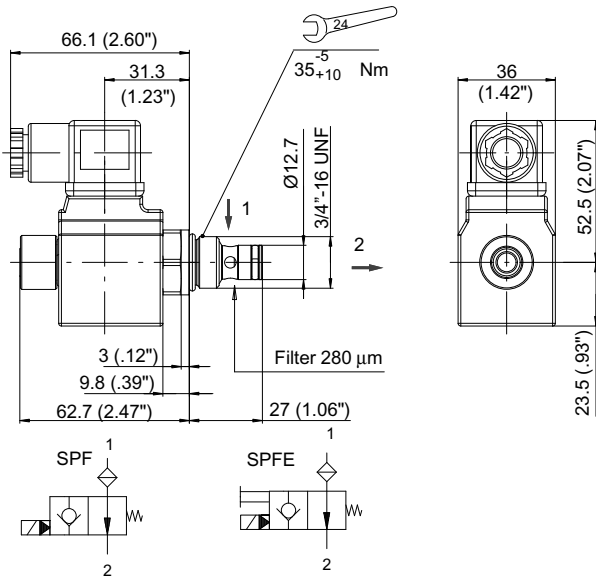

Weight (mechanical part only): 0.120 Kg

Performances	
Max. pressure (***)	300 bar
Max. recommended pressure	See 2.2
Max. flow	40 l/min.
Rated power	27 Watt
Intermittence	ED= 100%
Voltage tolerance	± 10% / -15%
Internal leakage	0.25 cm <sup>3</sup> /min.
Temperature range	-20/+90 °C
Connector type	DIN 43650
Time to open	<= 30 ms.
Time to close	<= 50 ms.

\*\*\* = max.admitted pressure when used into power pack bodies: 230 bar

Oil: Viscosity 46 cSt at 40°C

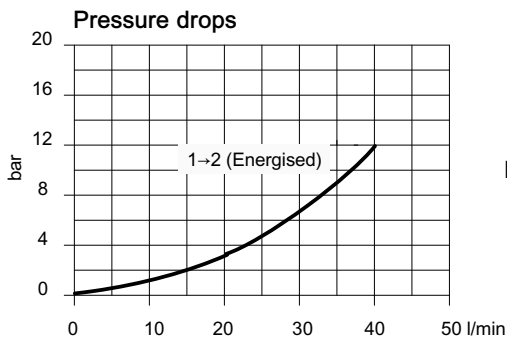

Minimum suggested working pressure = 5 bar

Type	Code*
ELVAL SPF817/22-TOV P.M.	200757200980
ELVAL SPFE817/22-TOV P.M.	200757200990

\* Mechanical part code only. For connector and coil see section: 7.3.5 - 7.3.6

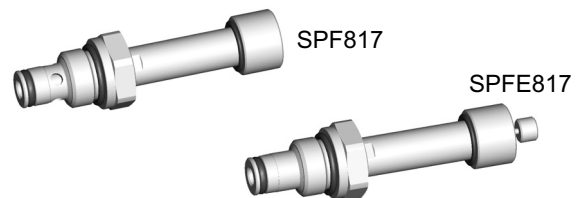

## 7.3.5 Directional valve solenoids

### SDF817 - SPFE817 (TV-TO) - SDFE817 - SPF817 (TO)

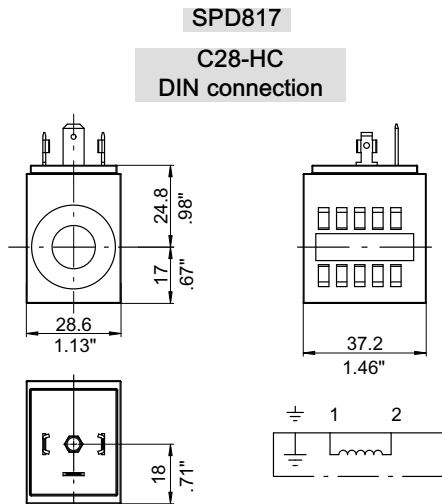
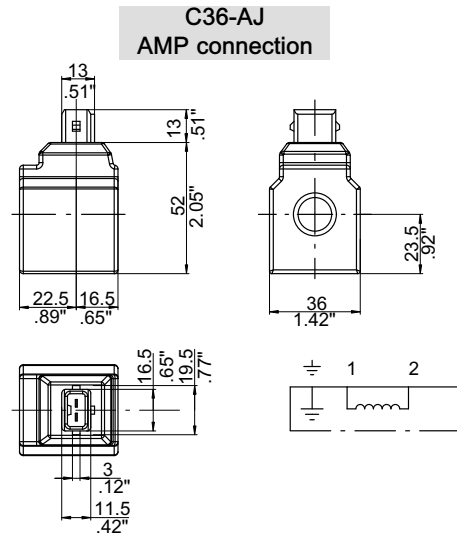
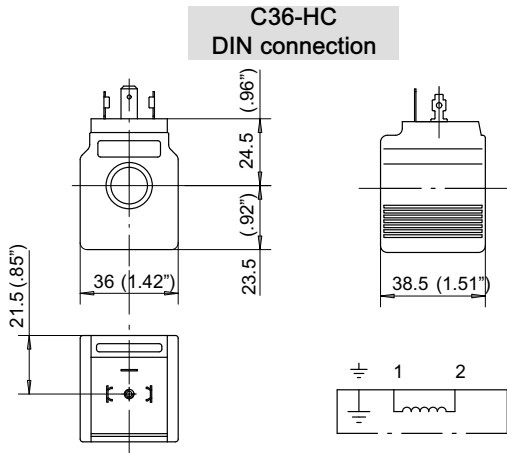

For solenoid valve series	C36-** SDF817 SPE817	C28-** SPD
Wire class	H (VDE0580)	
Protection	IP65 (DIN40050)	
Coil insulation	F	
Duty rating	ED 100%	
Connector style	DIN 43650 or AMP84-9419	DIN 43650
Stabilized temperature	70°C	95°C (DC vers.)
Voltage tolerance	± 10%	

Connector style	Supply Voltage	Nominal Coil voltage	Power (Watt)	Resistance (Ohm)		Current (Ampere)		Coil code	Voltage code	
				Ambient temp.	Stabil. temp.	Ambient temp.	Stabil. temp.			
C36-** SDF - SPFE - SDFE - SPF	DIN	12 V. DC.	12 V. DC.	27.2	5.3	8	2.2	1.5	200674910100	13
		24 V. DC.	24 V. DC.	27	21.3	32	1.12	0.75	200674920080	23
		48 V. DC.	48 V. DC.	27	85.3	130	0.56	0.37	200674930030	33
		24 V. AC.	21.6 V. DC.	27.1	17.2	26	1.25	0.83	200674820050	21
		110 V. AC.	98 V. DC.	27	355	530	0.27	0.18	200674840050	41
		220 V. AC.	198 V. DC.	27.6	1422	2130	0.14	0.10	200674860060	51
C36-** SDF - SPFE - SDFE - SPF	AMP	12 V. DC.	12 V. DC.	27.2	5.3	8	2.2	1.5	200674910250	13
		24 V. DC.	24 V. DC.	27	21.3	32	1.12	0.75	200674920200	23
		12 V. DC.	12 V. DC.	16	9	11.4	1.35	1.09	200541210039	13
		24 V. DC.	24 V. DC.	16	36	46.2	0.667	0.53	200541220037	23
		24 V. AC.	21.6 V. DC.	16	27.7	34.4	0.713	0.592	200541120015	21
		110 V. AC.	108 V. DC.	16	843	1053	0.15	0.1	200541140014	41
C28-HC SPD	DIN	220 V. AC.	216 V. DC.	16	3364	4168	0.624	0.498	200541160016	51

A.C. Supply requires a connector with bridge rectifier included.

## 7.3.6 Connector for solenoid directional valves

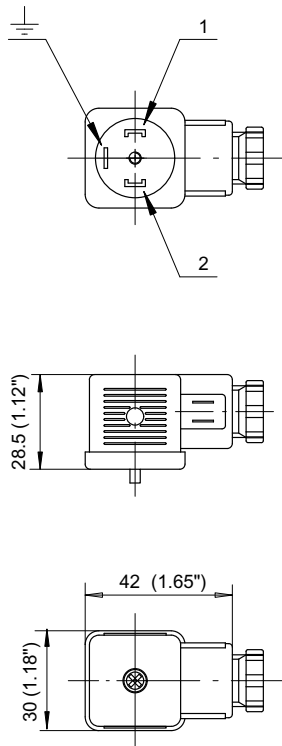

**CN-01**  
Part number:  
200544110009

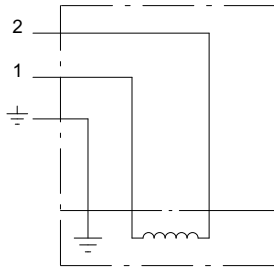

For power input	D.C.
Connector type	DIN 43650
Number of poles	2 + $\perp$
Supply voltage	max. 220 V.
Nom. capacity at contacts	10 A.
Max capacity at contacts	16 A.
Resistance at contacts	$\geq 4$ mOhm
Max section of cable	1.5 mm <sup>2</sup>
Outer material	Glass fibre reinforced Nylon
Contact mount material	Nylon
Color	Black
Armour clamp	Pg 9
Ø cable	6-8 mm.
Protection factor	IP65 (DIN40050)
Insulation class	C (VDE0110)
Temperature range	-40 / +90 °C

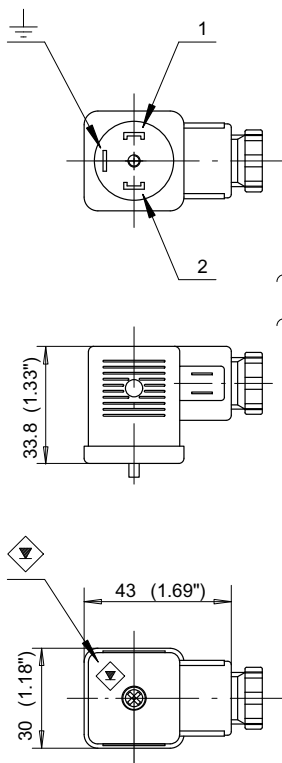

**CN-02**  
Part number:  
200544110012

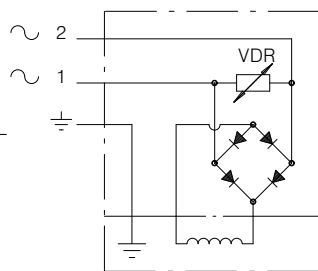

For power input	A.C.
Connector type	DIN 43650
Number of poles	2 + $\perp$
Supply voltage	max. 220 V.
Nominal capacity at contacts	10 A.
Max. capacity at contacts	16 A.
Resistance at contacts	$\geq 4$ mOhm
Max. section of cable	1.5 mm <sup>2</sup>
Outer material	Glass fibre reinforced Nylon
Contact mount material	Nylon
Color	Black
Diodes	1N 4007 GP
Overvoltage protection	VDR
Armour clamp	Pg 9
Ø cable	6-8 mm.
Protection factor	IP65 (DIN40050)
Insulation class	C (VDE0110)
Temperature range	-40 / +90 °C

### 7.3.7 Proportional solenoid valve: PPF817/TV-03

Normally closed  
 Poppet type  
 Flow from 1 to 2

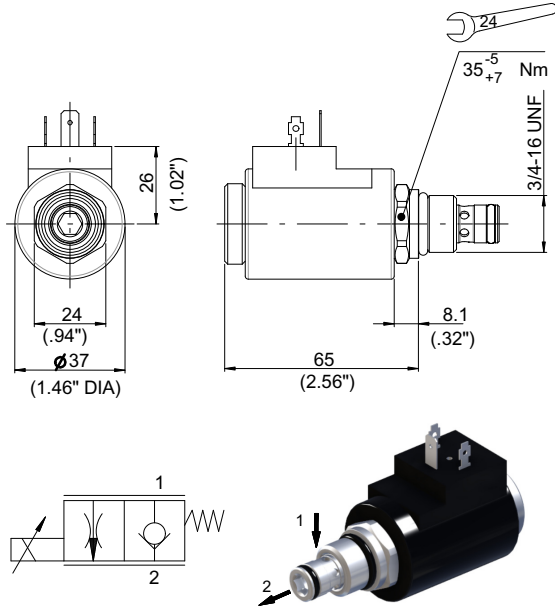

Electric performances 24 V	
Max. pressure	250 bar
Max. flow	30 l/min
Max internal leakage	5 drops/min
Voltage type	12 VDC
Voltage tolerance	+10% / -15%
Coil power	26 w
ED	100%
Fluids	Mineral based or synthetics with lubricating properties
Oil viscosity	7.4 to 420 cSt
Oil temperature range	-30° to 110°C
Recommended filtration	20/18/15 ISO 4406 (9NAS 1638)

Pressure drops

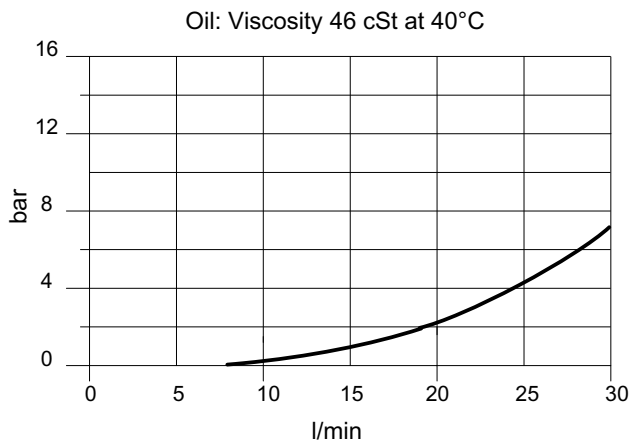

Typical hysteresis

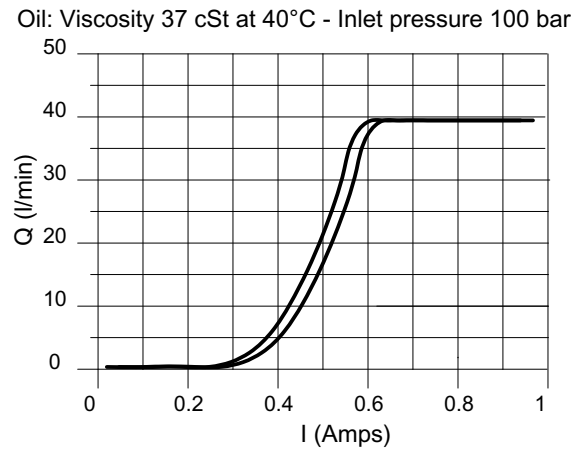

Type	Code*
ELVAL PPF817/TV-03 P.M.	200533960022
COIL 24 V. DC.	200674920020

## 7.4 Mechanical valves

### 7.4.1 Check valve: VR05

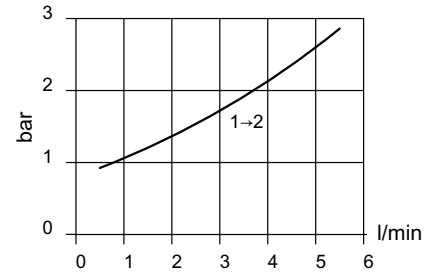
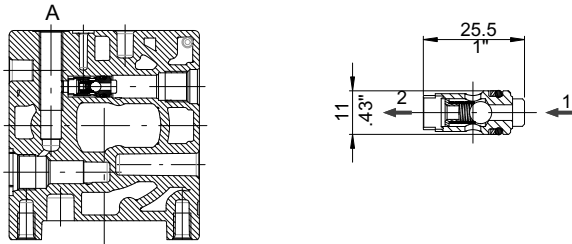

Type	Code
VR05	200787601330

### 7.4.2 Piloted check valve: VRP05

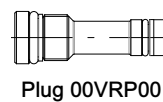
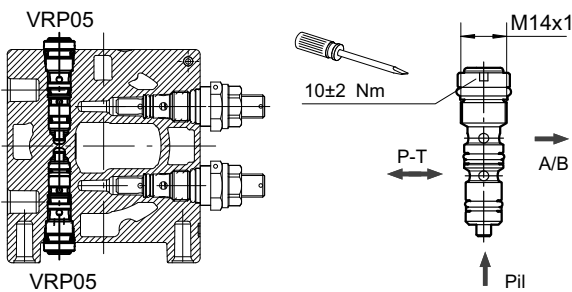

Plug 00VRP00

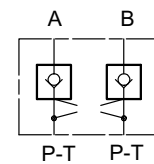

Pilot ratio 3.4:1

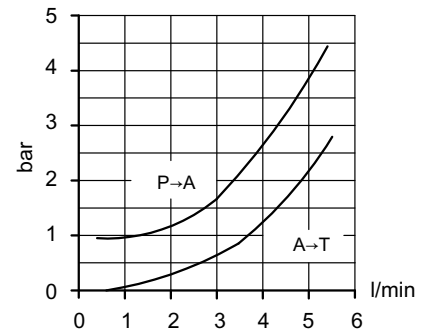

Type	Code
VRP05	200787600920
00VRP00	200778400430

To be assembled in K50 - K51 housings only

### 7.4.3 Throttle compensated flow control valve: VRC05

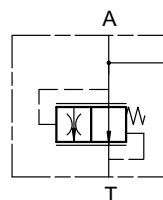
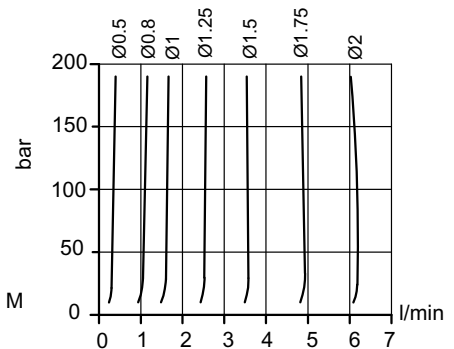
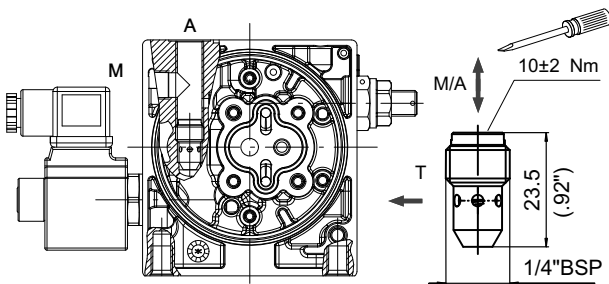

To be assembled in K04 - K41 housing only

Type	Hole	Controlled flow Q	Code
	Ø	l/min	
VRC05/0.35	0.5	0.35	200787200250
VRC05/1	0.8	1	200787200260
VRC05/1.6	1	1.6	200787200270
VRC05/2.5	1.25	2.5	200787200280
VRC05/3.5	1.5	3.5	200787200290
VRC05/4.9	1.75	4.9	200787200300
VRC05/6	2	6	200787200310

Flow tolerance = ±15%

## 7.5 Manual lowering valve

### 7.5.1 Manual lowering valve: ZR817/22-TV

For housings:  
 UP50/K34  
 UP50/K17-K04-K41-K42-K46  
 Normally closed  
 Code ..... 200987601960

Max. pressure ..... 230 bar  
 Max. recommended pressure ..... 210 bar  
 Max flow ..... 25 l/min.  
 Internal leakage ..... 0-5 drops/min.  
 Temperature range ..... -20/+90 °C  
 O-Ring replacement kit ..... 200974200160

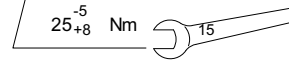
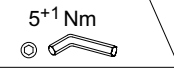
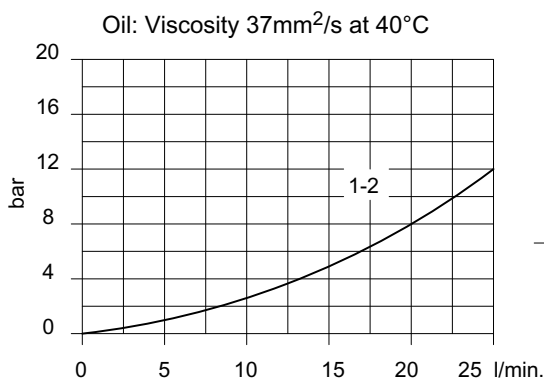
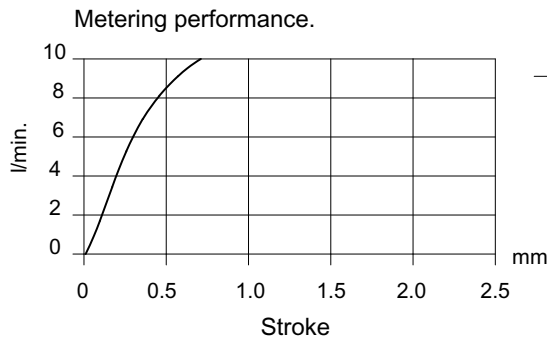
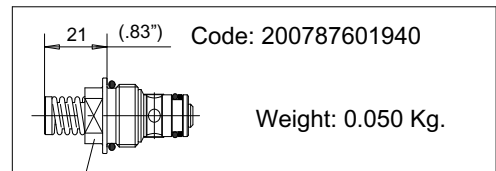
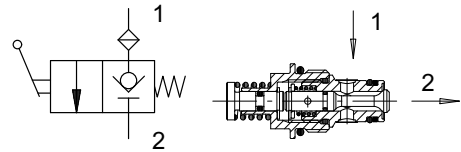
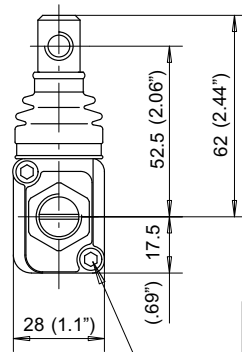
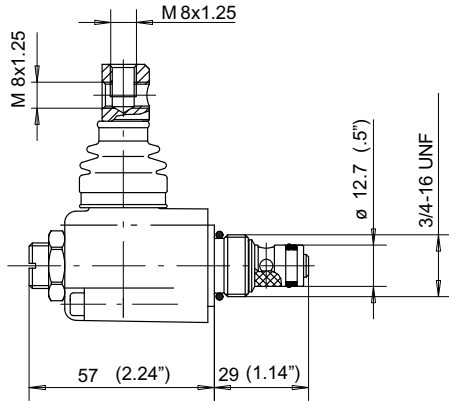

The connecting end of the lever allows the handle to be mounted in two different positions.

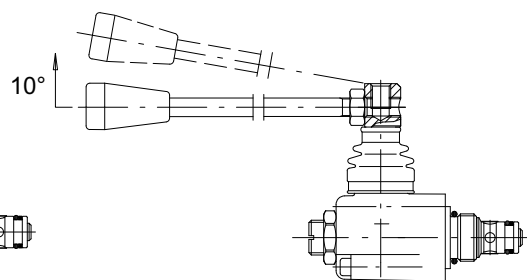
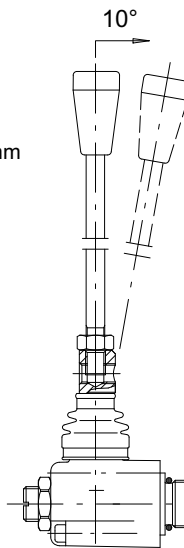

Mounting positions: see 7.5.3

Lever stick

7	Lever stick				
	A	L	0	0	1

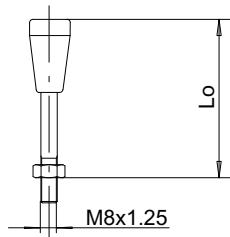

Lo Length	Type	Code
150 mm-5.90 inches	AL001	200702210190
200 mm-7.87 inches	AL002	200702210030
250 mm-9.84 inches	AL003	200702210050
300 mm-11.80 inches	AL004	200702210060

## 7.5.2 Manual lowering valve with microswitch: ZR817/22-TVM

For housings:  
UP50/K34  
UP50/K17-K04-K41-K42-K46  
Normally closed  
Code ..... 200987601950

Max. pressure ..... 230 bar  
Max. recommended pressure ..... 210 bar  
Max flow ..... 25 l/min.  
Internal leakage ..... 0-5 drops/min.  
Temperature range ..... -20/+90 °C  
O-Ring replacement kit ..... 200974200160

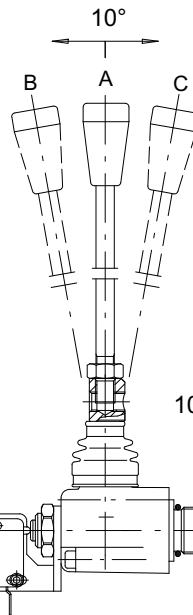
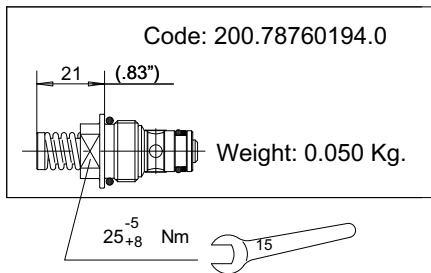
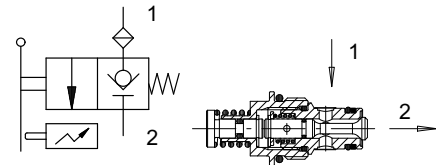
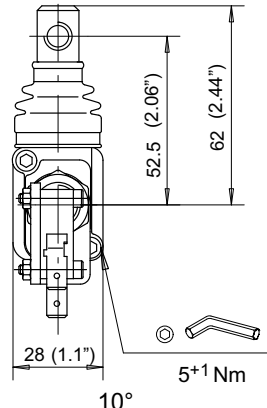
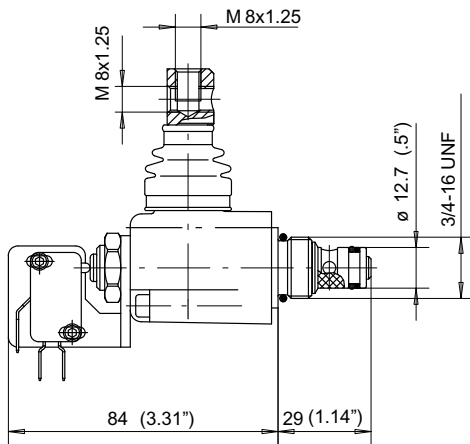

A → B = Microswitch operated  
A → C = Hydraulically operated

The connecting end of the lever allows the handle to be mounted in two different positions.

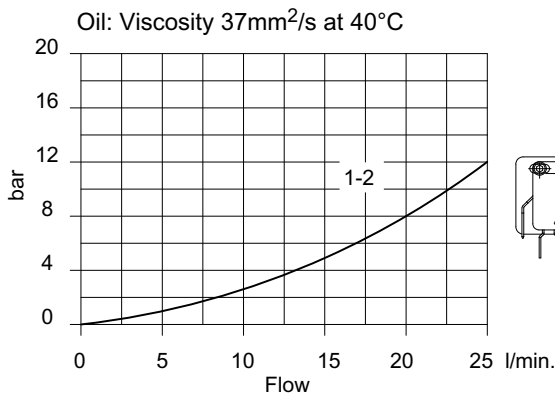
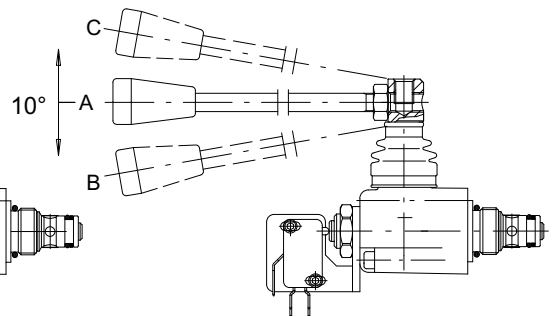

Mounting positions: see 7.5.3

Lever stick

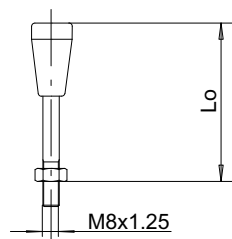
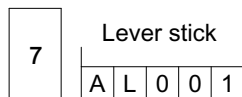

Lo Length	Type	Code
150 mm-5.90 inches	AL001	200702210190
200 mm-7.87 inches	AL002	200702210030
250 mm-9.84 inches	AL003	200702210050
300 mm-11.80 inches	AL004	200702210060

### 7.5.3 Manual lowering valve mounting positions

ZR817/22-TV: L10-L11-L12-L13-L14-L15

ZR817/22-TVM: L30-L31-L32-L33-L34-L35

Hand lever

L	1	0
L	3	0

Lever stick

A	L	0	0	*
---	---	---	---	---

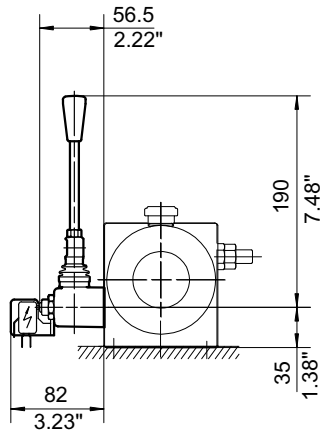

Hand lever

L	1	1
L	3	1

Lever stick

A	L	0	0	*
---	---	---	---	---

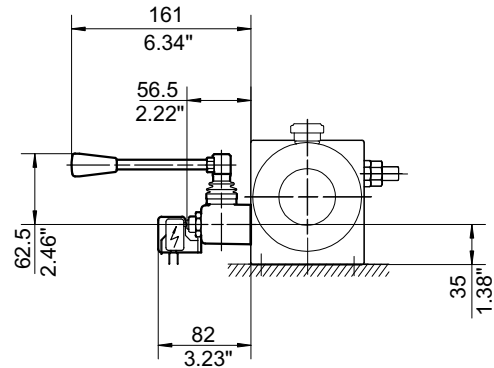

Hand lever

L	1	2
L	3	2

Lever stick

A	L	0	0	*
---	---	---	---	---

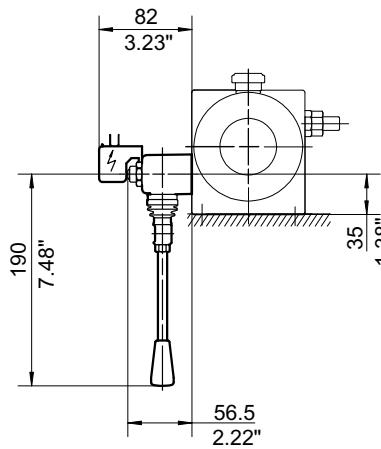

Hand lever

L	1	3
L	3	3

Lever stick

A	L	0	0	*
---	---	---	---	---

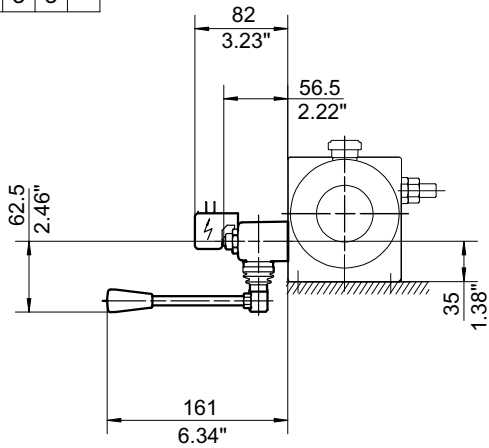

Hand lever

L	1	4
L	3	4

Lever stick

A	L	0	0	*
---	---	---	---	---

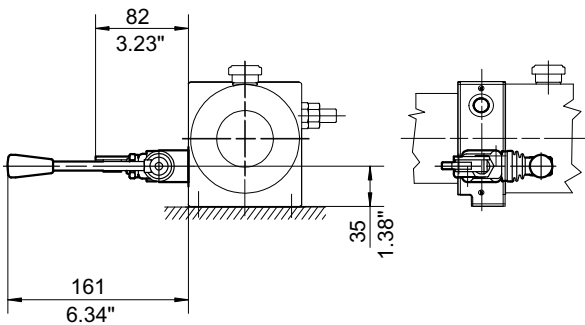

Hand lever

L	1	5
L	3	5

Lever stick

A	L	0	0	*
---	---	---	---	---

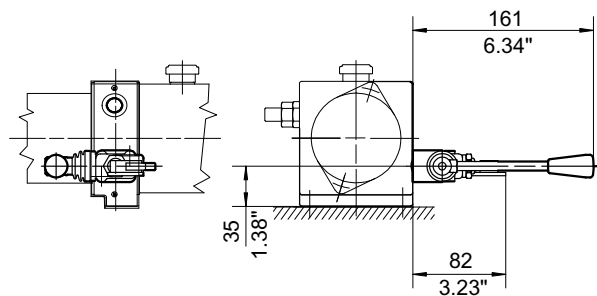

## 7.5.4 Manual lowering valve with safety lever support and without microswitch :

### ZR817/22-TVS

For housings:  
 UP50/K34  
 UP50/K17-K04-K41-K42-K46  
 Normally closed  
 Code ..... 200987601970

Max. pressure ..... 230 bar  
 Max. recommended pressure ..... 210 bar  
 Max flow ..... 25 l/min.  
 Internal leakage ..... 0-5 drops/min.  
 Temperature range ..... -20/+90 °C  
 O-Ring replacement kit ..... 200974200160

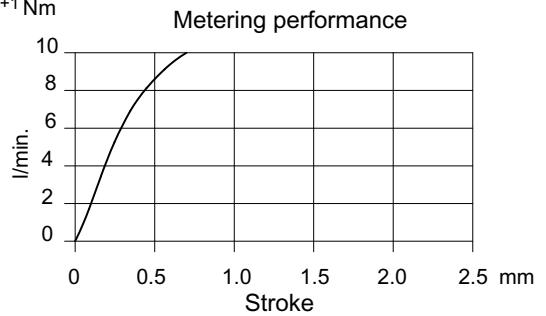
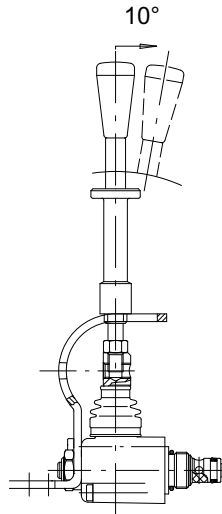
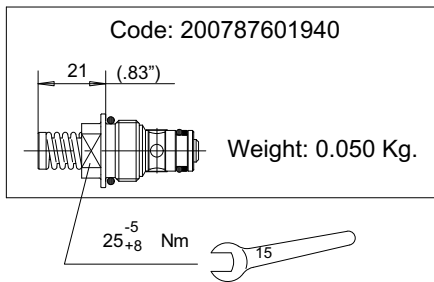
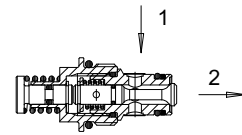
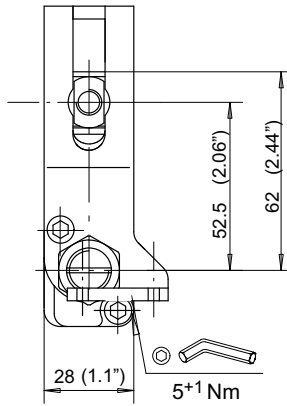
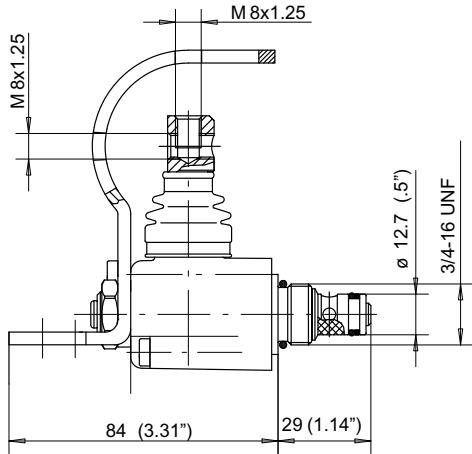

The connecting end of the lever allows the handle to be mounted in two different positions.

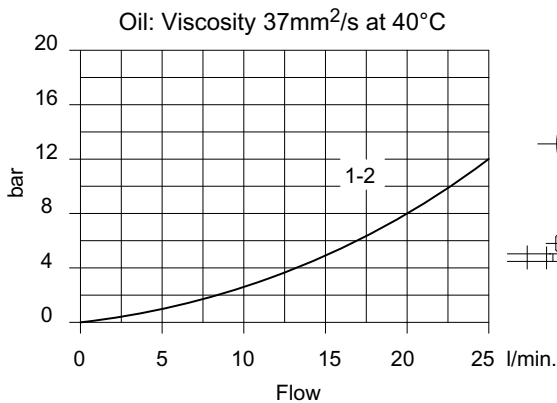
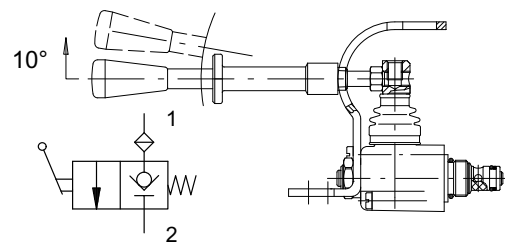

Mounting positions: see 7.5.6

### Lever Stick

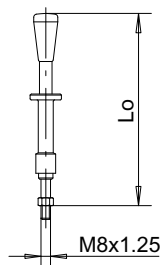
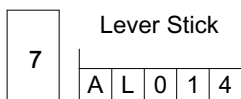

Lo Length	Type	Code
160 mm-6.29 inches	AL014-E	200702210090
122 mm-4.82 inches	AL002-E	200702210040

## 7.5.5 Manual lowering valve with microswitch and safety lever support: ZR817/22-TVMS

For housings:  
 UP50/K34  
 UP50/K17-K04-K41-K42-K46  
 Normally closed  
 Code ..... 200987601980

Max. pressure ..... 230 bar  
 Max. recommended pressure ..... 210 bar  
 Max flow ..... 25 l/min.  
 Internal leakage ..... 0-5 drops/min.  
 Temperature range ..... -20/+90 °C  
 O-Ring replacement kit ..... 200974200160

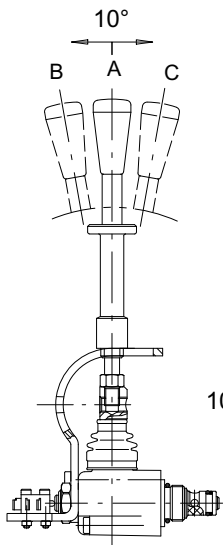
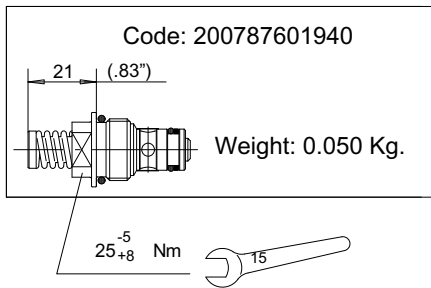
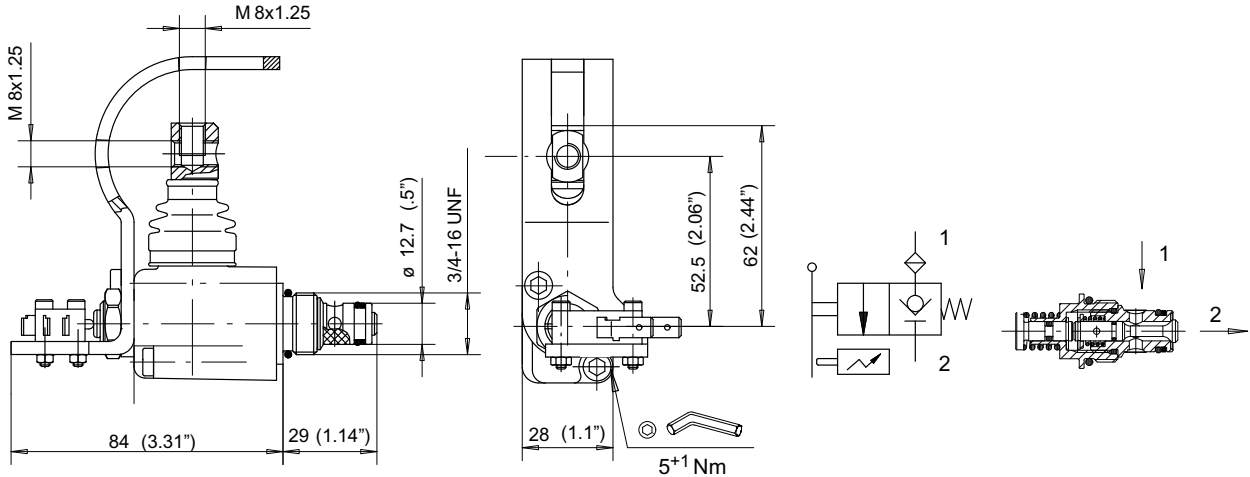

A → B = Microswitch operated  
 A → C = Hydraulically operated

The connecting end of the lever allows the handle to be mounted in two different positions.

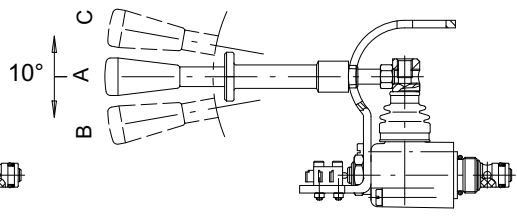
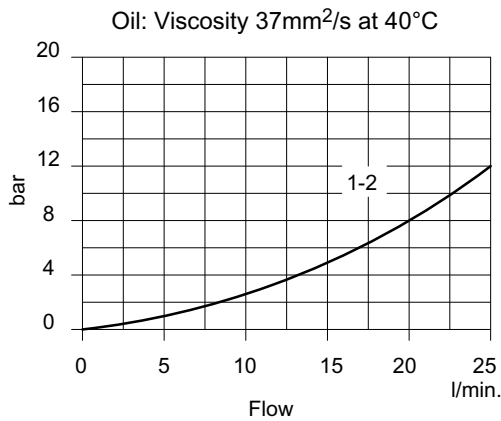

Mounting positions: see 7.5.6

### Lever Stick

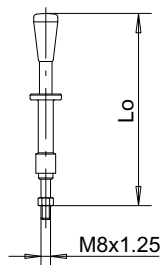
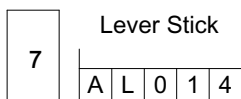

Lo Length	Type	Code
160 mm-6.29 inches	AL014-E	200702210090
122 mm-4.82 inches	AL002-E	200702210040

7.5.6 Manual lowering valve mounting positions

ZR817/22-TV: L50-L51-L52-L53-L54-L55

ZR817/22-TVM: L70-L71-L72-L73-L74-L75

Hand lever

L	5	0	
L	7	0	

Lever stick

A	L	0	0	*
---	---	---	---	---

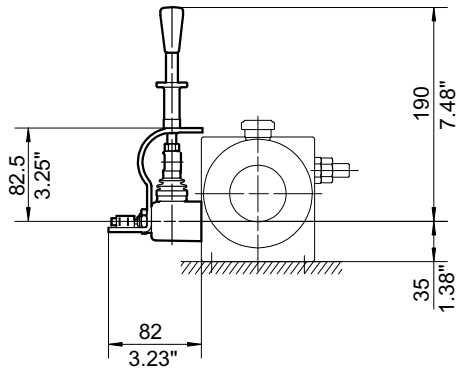

Hand lever

L	5	1	
L	5	1	

Lever stick

A	L	0	0	*
---	---	---	---	---

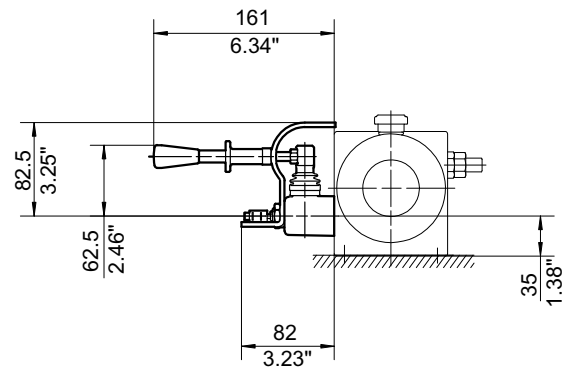

Hand lever

L	5	2	
L	7	2	

Lever stick

A	L	0	0	*
---	---	---	---	---

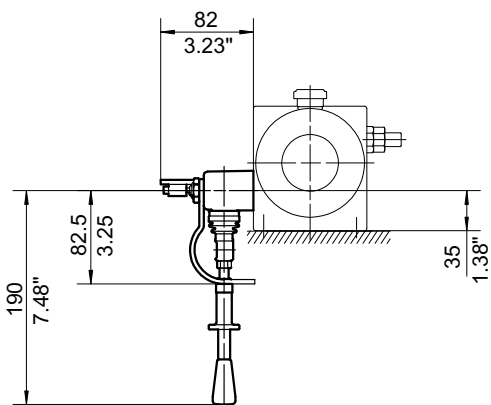

Hand lever

L	5	3	
L	7	3	

Lever stick

A	L	0	0	*
---	---	---	---	---

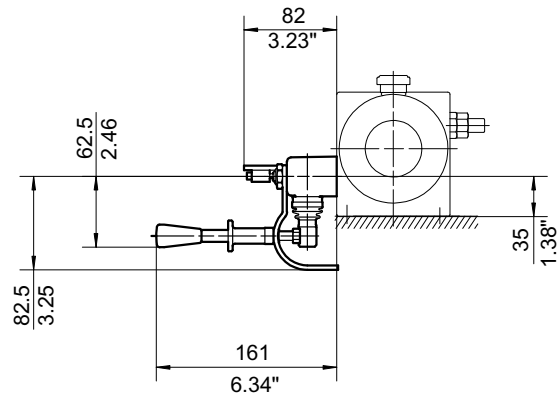

Hand lever

L	5	4	
L	7	4	

Lever stick

A	L	0	0	*
---	---	---	---	---

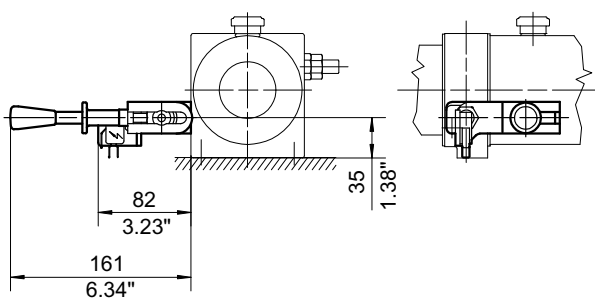

Hand lever

L	5	5	
L	7	5	

Lever stick

A	L	0	0	*
---	---	---	---	---

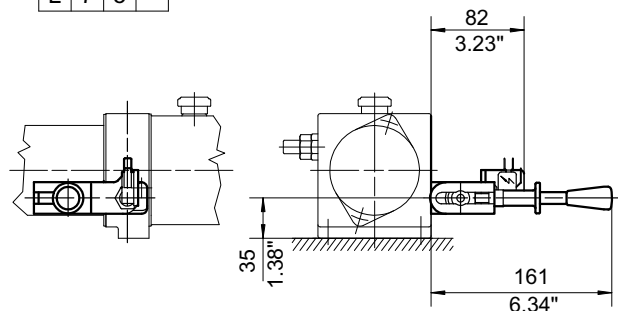

## 7.6 Emergency hand pump: PM817/1.5

For housings:

**UP50/K46**

Inlet check

Outlet check

Ball type

Code ..... 200948200080

Max recommended pressure ..... 210 bar

Displacement ..... 1.5 cm<sup>3</sup>

Internal leakage ..... 0-5 drops/min.

Temperature range ..... -20/+90 °C

O-Ring replacement kit ..... 200974200340

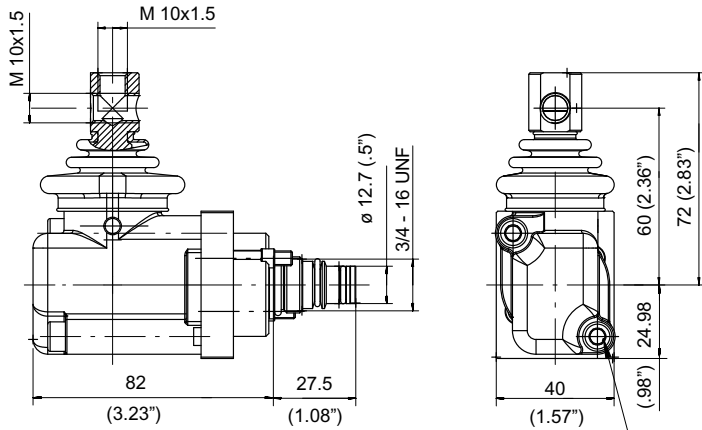

The connecting end of the lever allows the handle to be mounted in two different positions.

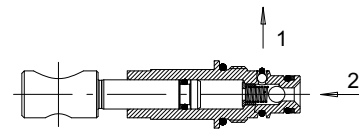
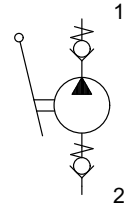

5+1 Nm

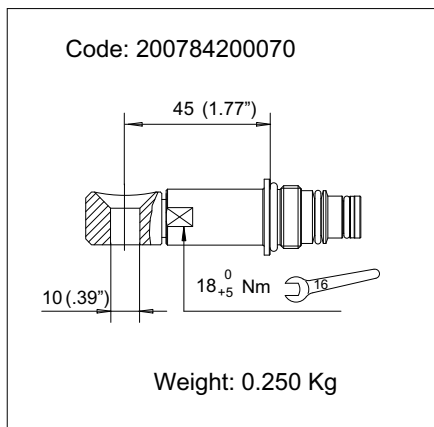

With the hand pump assembled into a special manifold (see 1.3.5) a suction pump having proper length, in function of the type and capacity of the tank has to be fitted into the appropriate position\*

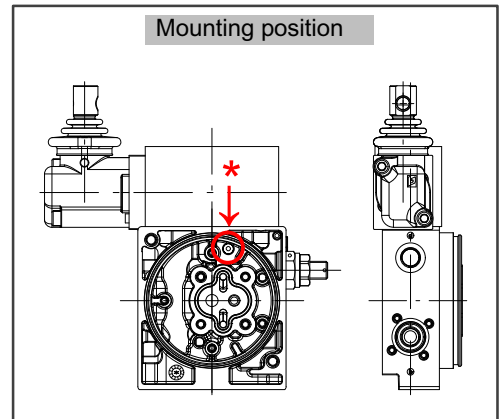

B → A = Inlet  
A → B = Outlet

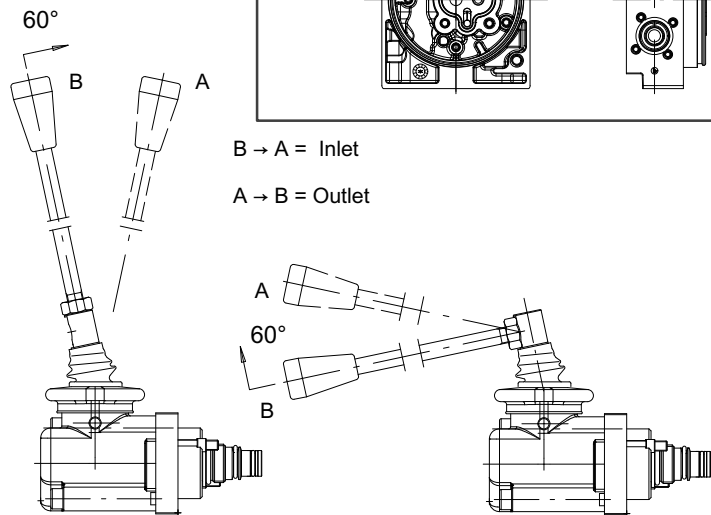

Lever stick

7	Lever stick			
	A	L	0	0

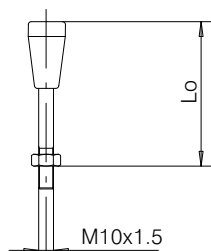

L <sub>0</sub> Length	Type	Code
185 mm-7.28 inches	AL001	200702220010
250 mm-9.84 inches	AL002	200702220030
300 mm-11.81 inches	AL003	200702220040
350 mm-13.78 inches	AL004	200702220050

## 7.7 Valve cavity plugs

### 7.7.1 Valve cavity plug T817/2

Two way

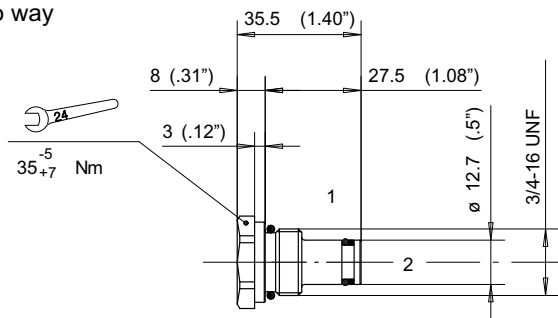

Code	200778800020
Seal kit code	200974200160
Weight	0.070 Kg.

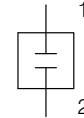

### 7.7.2 Valve cavity plug T817/2P-602

Pressure port available

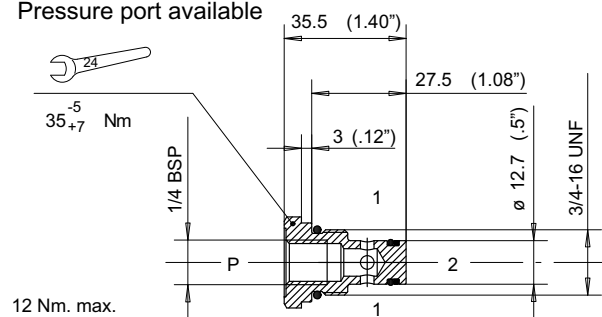

Code	200778800060
Seal kit code	200974200160
Weight	0.040 Kg.

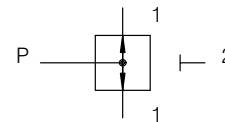

### 7.7.3 Valve cavity plug T817/2T-602

Return port available

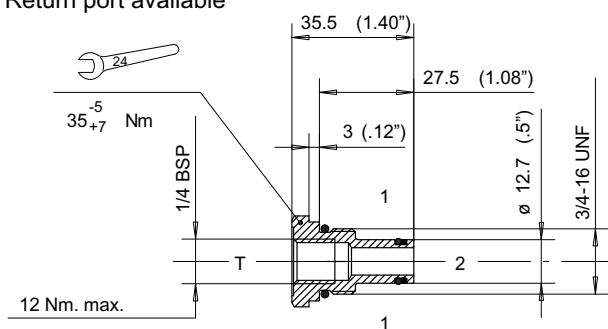

Code	200778800070
Seal kit code	200974200160
Weight	0.030 Kg.

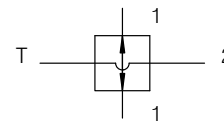

## 8 Manifolds

(For availability please consult our Sales Organisation)

### 8.1 Technical information

Power pack housings K03 and K34 can be connected with manifolds, allowing the assembly of complex circuits in compact and modular solution.

#### 8.1.1 Standard manifolds

The range includes monobloc or sectional manifolds with which to create parallel or series circuits for cartridge type solenoid valves or CETOP R35H design.

Take care to verify the positions of the filling plug of the chosen tank/electrical motor avoiding version having interference with the valve block.

#### 8.1.2 Special manifolds

To reduce the dimensions and complexity of the system generally (connecting pipe-lines, etc.) special manifolds can be designed and manufactured to meet particular requirements.

#### 8.1.3 Material

Manifold elements are in extruded aluminium alloy.

The O-Rings utilized will be NBR-70sh. unless other types are specifically requested.

## 8.2 Manifold for parallel circuit

### 8.2.1 Manifold for single solenoid valves, cartridge style

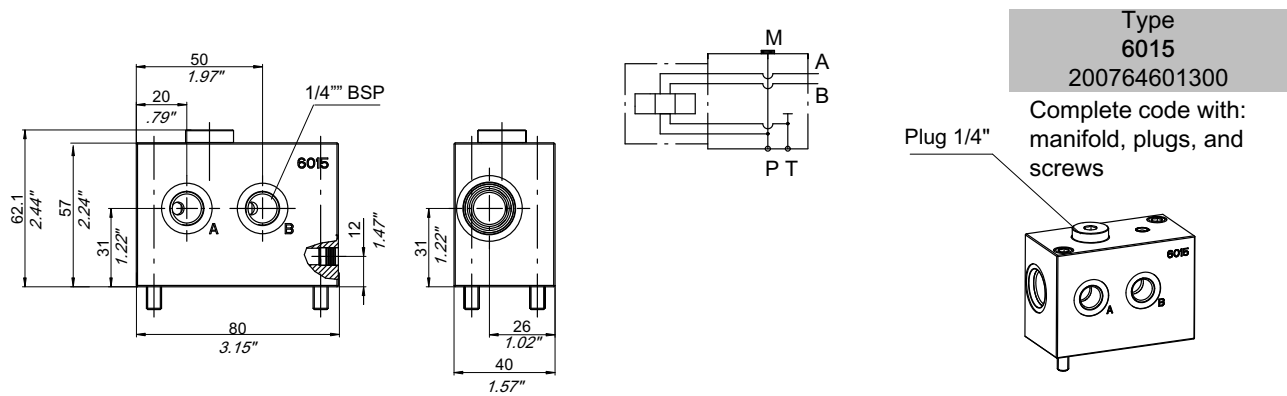

### 8.2.2 Manifold for two solenoid valves, cartridge style

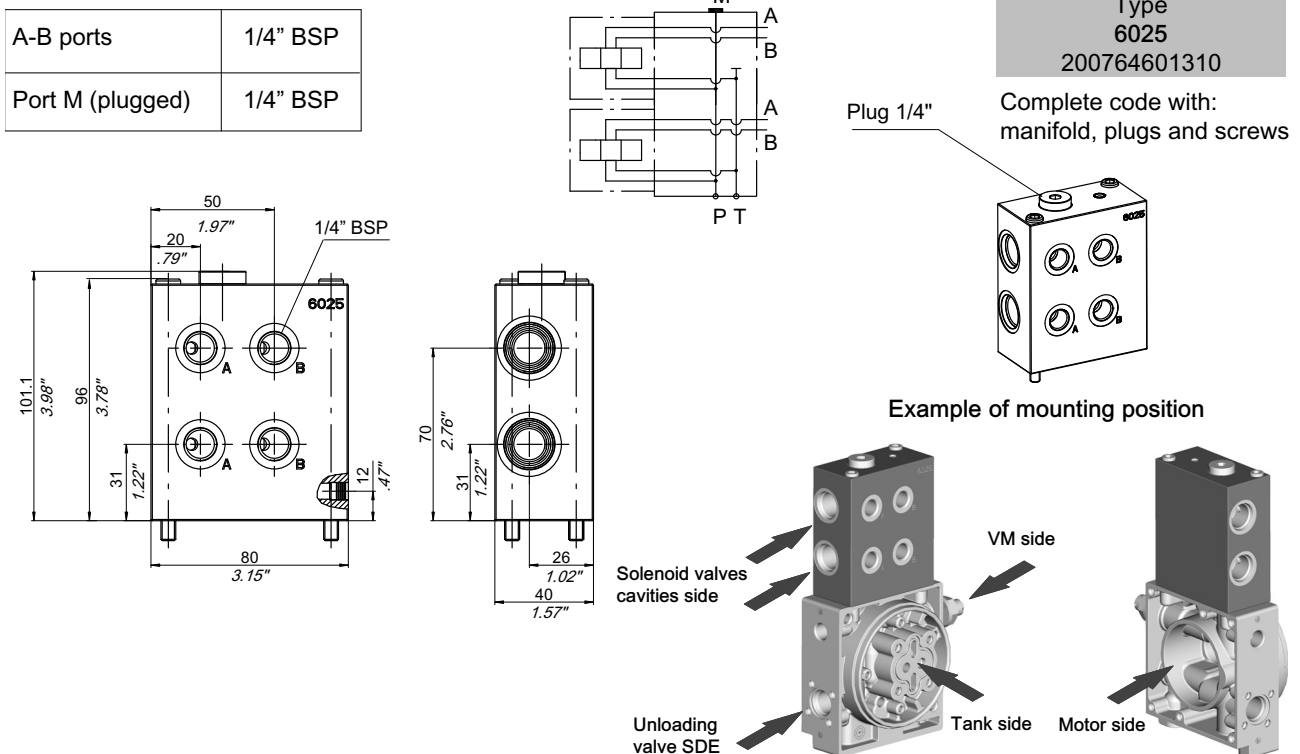

8.2.3 Manifold for three solenoid valves, cartridge style

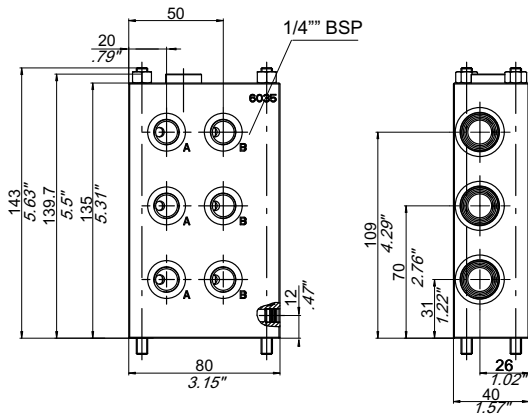

Type  
6035  
200764601320  
Complete code with:  
manifold, plugs tie-rods  
and nuts

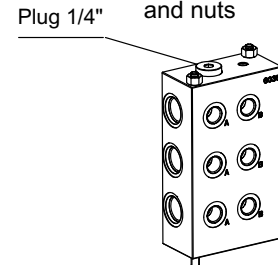

8.2.4 Manifold for four solenoid valves, cartridge style

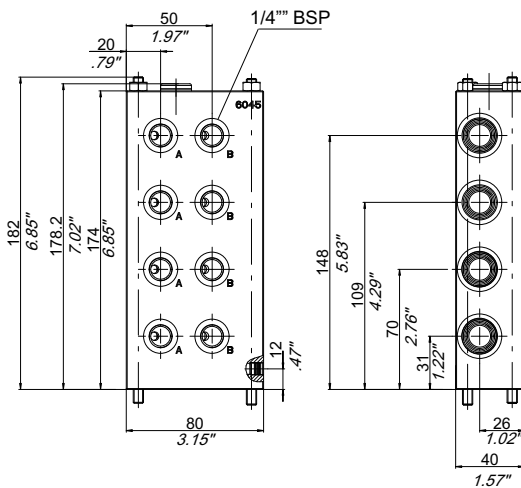

Type  
6045  
200764601330  
Complete code with:  
manifold, plugs, washer,  
tie-rods and nuts

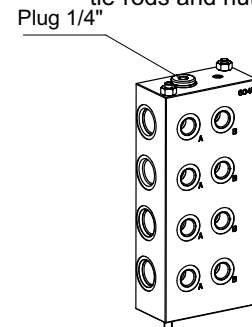

8.2.5 Intermediate manifold for horizontal assembly

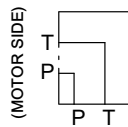
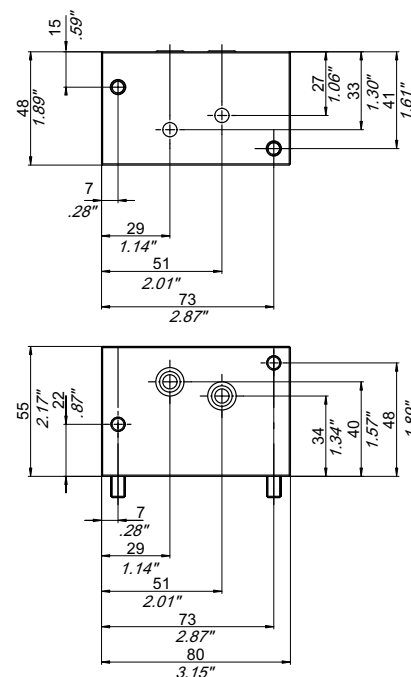

Type  
4011  
200764900400  
Complete code with:  
manifold, OR and  
screws

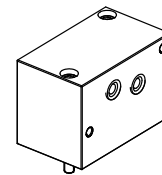

Example of mounting position

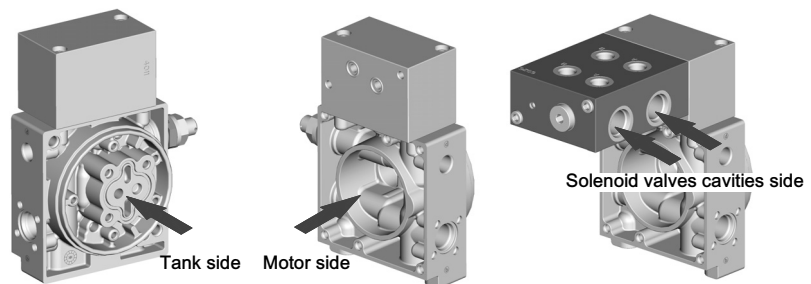

## 8.3 Manifold for series circuit

### 8.3.1 First manifold

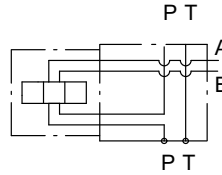
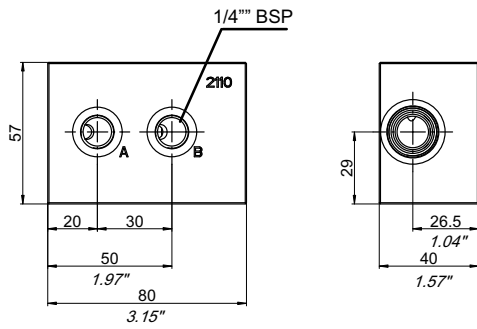

Type  
2110  
200764400170

Complete code with:  
manifold and plugs

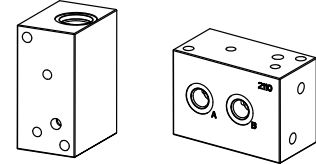

### 8.3.2 Intermediate manifold

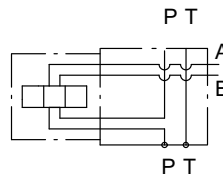
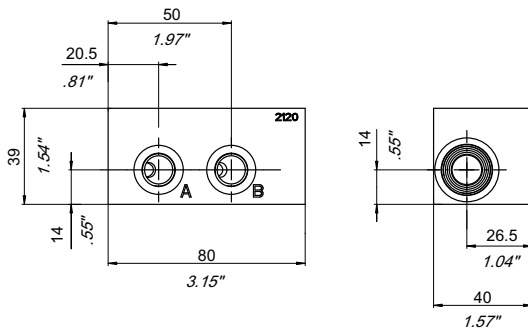

Type  
2120  
200764400180

Complete code with:  
manifold, OR and plugs

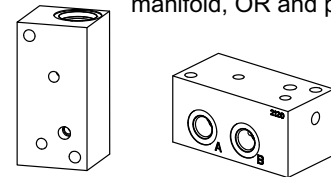

### 8.3.3 End manifold

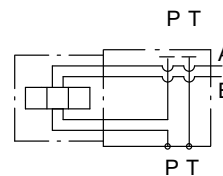
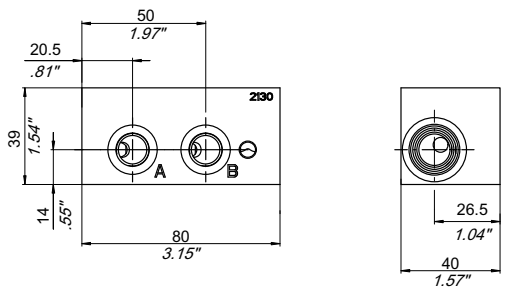

Type  
2130  
200764400190

Complete code with:  
manifold, O-Ring and plugs

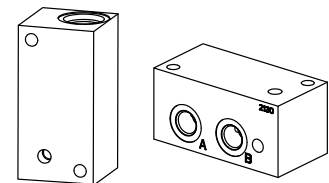

### Example of assembling/mounting position

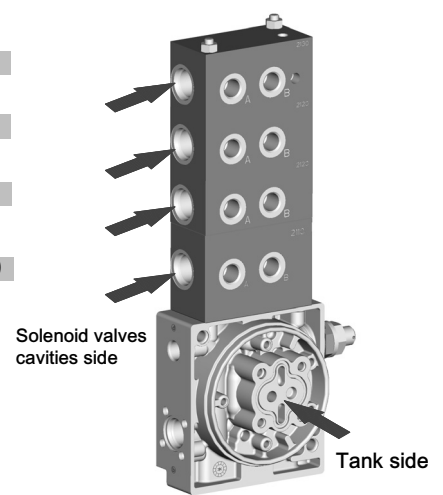
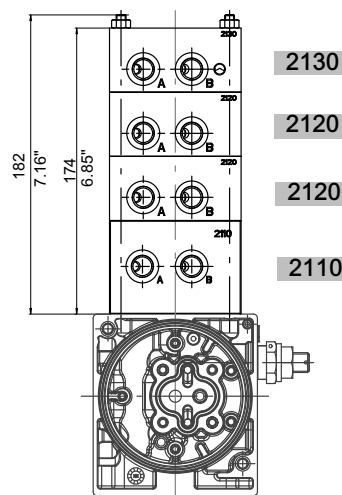
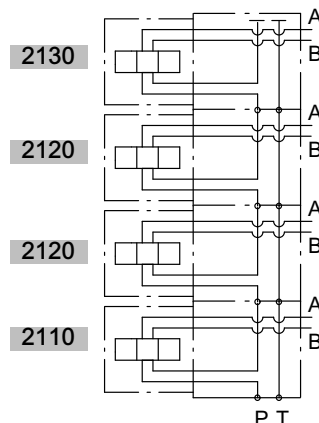

**8.3.4 Intermediate manifold (spacer only)**

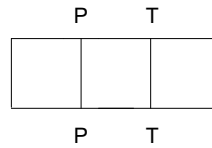
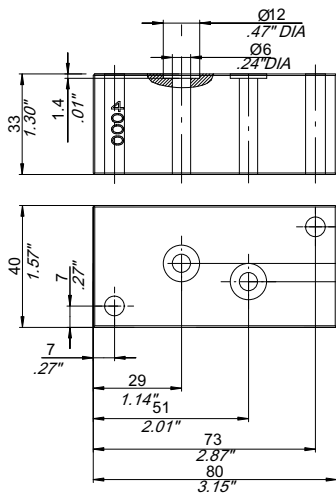

Type  
4000  
200764900020

Complete code with:  
manifold and O-Rings

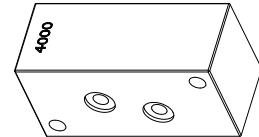

**8.3.5 Intermediate manifold (UP50 → UP100 interface)**

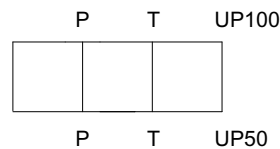
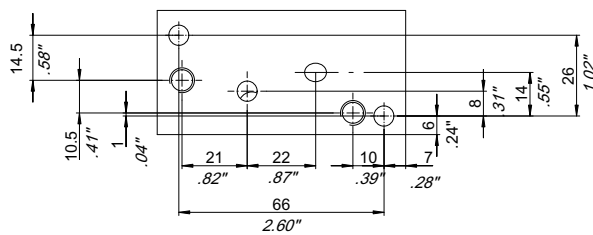
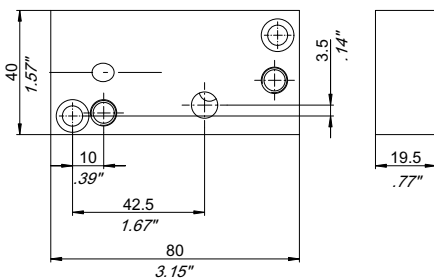

Type  
4237  
200664900550

Only manifold

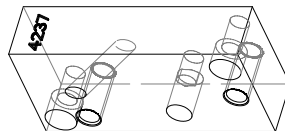

Intermediate manifold suitable to connect UP100 manifolds : 5073-5033-5053-2083-2043-2013. For details see section 8 of the UP100 catalogue

**8.3.6 Intermediate manifold for PM817/1.5  
(see section 1.3.5)**

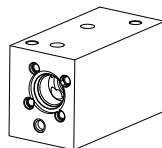
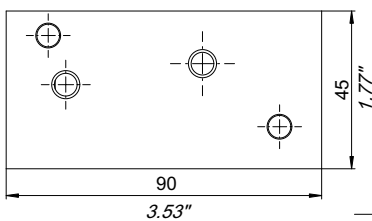

PM817/1.5  
200748200080

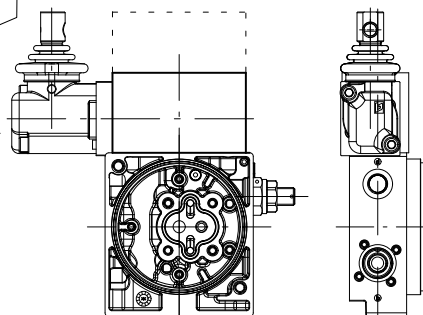

Type  
4030  
200764900390

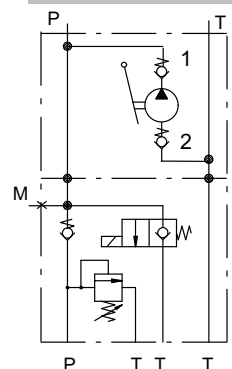

Available also single manifold 4031 code 200764900480 without intermediate module

## 8.4 Solenoid valves dedicated to Manifolds

(For availability please consult our Sales Organisation)

Circuit	Type
	CH-01
	CB-01
	CA-01
	CI-01
	CB-02
	CC-02
	CA-02
	CD-02

### 4 ways, two positions

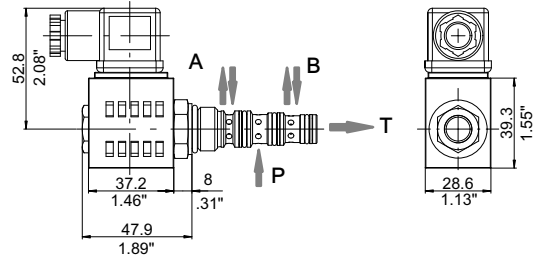

### 4 ways, three positions

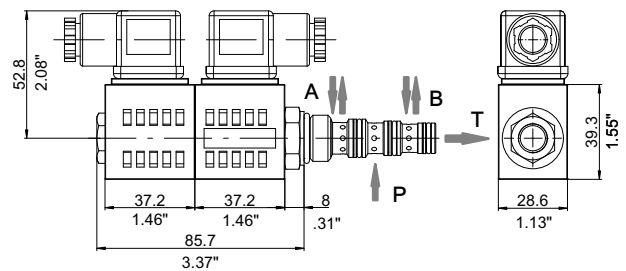

Std. Voltage	Type	
12 V D.C.	13	Coil and connector features: see section 7.3.5 (SPD type) and 7.3.6
24 V D.C.	23	
24 V A.C.	21	
110 V A.C.	41	
220 V A.C.	51	

Hydraulic performances		
Max. pressure	210 bar	For higher pressure/flow rate values please contact our Sales Center
Max. flow	11 l/min	

## 9 Components

### 9.1 Steel plate bracket pressed for UP housing SL01

Code  
200977400120

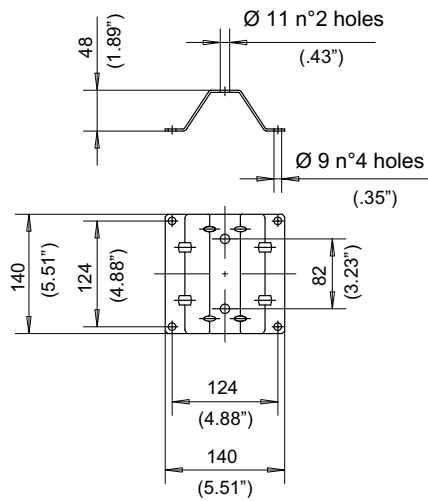

### 9.2 Protective cover PP01 for D.C. motors

Code  
200968800090

Only for motors:  
T82K, C134AK, C238AK

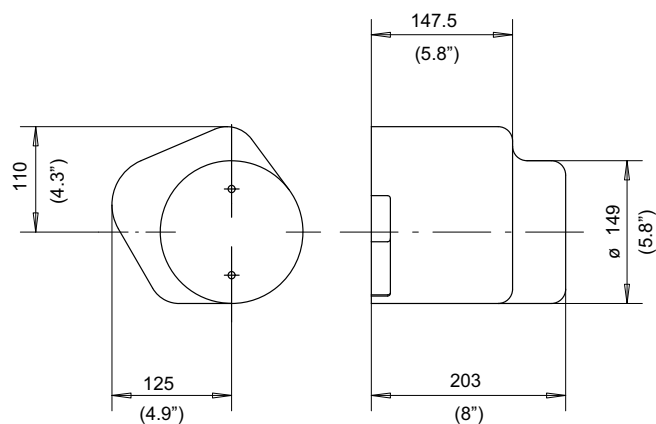

### 9.3 Microswitch

Code  
200544124014

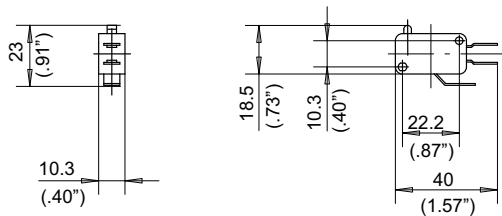

Code MS01 (micro only)	200544124014
Complete code MS01-K (micro + fixing kit)	200762500050
Voltage	250 V.
Index protection	IP00
Nominal current	16 A.
Max. current	20 A.
Temperature range	-20/+125°C
Max total stroke	2.6 mm.
Working stroke	1.2 mm.
Mechanical life	2x10 <sup>7</sup> cycles
Suitable for	ZR817/**

## 10 Operation and maintenance

This chapter lists the main guidelines that should be followed to ensure smooth operation and long life service life of the power pack.

### 10.1 Oil

Use only a mineral based hydraulic oil responding to ISO/DIN 6743/4.

Other types of fluid can use serious damage to the power pack and jeopardize its correct operation.

Recommended viscosity is between 20 and 120 mm<sup>2</sup>/s.

Contamination levels must be no higher than class 18/15 as prescribed by ISO 4406.

Check that the oil level is correct when filling the tank.

### 10.2 Starting

Connect the e. motor according paragraph 5.2 and check that the direction of rotation is correct by supplying power for 1-2 seconds only.

For power packs which use pump series AP100 S409 and AP100 S509 the correct rotation is counterclockwise, viewed from the fan side.

Bleed the system of any air, then fill up the oil level in the tank after the initial period of operation.

For systems using solenoid valves with a.c. voltage, check before operating that is fitted the right type of electric connector.

### 10.3 Maintenance

Check the oil level in the tank on a regular basis.

Following the first few hours operation, inspect the return line filter to verify the rate of pollution, and generally check the level of contaminants in the oil.

Clean the tank inside periodically and replace the oil after every 500-600 hours operation.

In heavy duty conditions or hostile environments, inspections and oil changes should be carried out more often.

Likewise periodically, check the power connections to the electric motor, the solenoid valves and any other electrical accessories (e.g. microswitches, etc.).

In the event that the O-Rings of cartridge valves need to be renewed, use the replacement parts kit specified for each of the valves in the catalogue, positioning the seal and the backup ring as indicated.

Avoid makeshift arrangements using different seals.

### 10.4 Dealing with possible trouble

This is intended to assist those customers who choose to purchase single sub-assemblies separately and put together their own power packs. Listed below are some of the more commonplace problems that can occur if parts are not assembled correctly.

Trouble observed: <b>Oil leaking from spigot on tank side</b>	
Probable reasons:	Possible remedies:
O-Ring damaged	Inspect and replace O-Ring

Trouble observed: <b>Motor turning but no pressure in circuit</b>	
Probable reasons:	Possible remedies:
Hydraulic circuit wrongly assembled	Inspect position and type of plugs and valves fitted into the cavities
Solenoid valve normally open energized by not correct or lower tension	Check energizing with the correct nominal input voltage.
Solenoid valve normally closed but continuously energized.	Check electrical connections.
Electric motor rotates in wrong direction	Check and modify the electric connection
Pump bearings fitted incorrectly	Check and re-assembling correctly
Pressure relief valve set at not correct valve	Check with a gauge and set to the correct pressure
The pump does not suck oil owing to low oil level in the tank	Check and fill the tank with correct oil level
The drive coupling between pump and e. motor is not correctly assembled	Check and assemble in the correct position

Trouble observed: <b>Cylinder rod extends correctly, but fails to retract when unloading valve is opened</b>	
Probable reasons:	Possible remedies:
Solenoid unloading valve not energized	Check electrical connections
Solenoid unloading valve not energized with nominal input voltage	Check power input and restore nominal voltage.
Solenoid valve has lower performances compared to the circuit requirements. consequently unable to handle flow/pressure.	Verify, and replace with a model giving higher performances.
The solenoid valve is blocked because of dirt in the system	Disassemble and clean
Valve solenoid damaged by overheating	Possible overvoltage. Check rated voltage of solenoid against input voltage. If system is using a.c., make certain the type of the connector is correct.

Trouble observed: <b>Cylinder rod does not keep the position due to internal leakage</b>	
Probable reasons:	Possible remedies:
Dirt in the system	Clean up components and restore system to a suitable level of cleanliness. Check that valve elements and seats are undamaged. Check piston seals for wear.

Trouble observed: <b>Oil leaking on motor side</b>	
Probable reasons:	Possible remedies:
Pump shaft seal damaged during assembling	Check seal, and replace if it is necessary

Trouble observed: <b>High noise level</b>	
Probable reasons:	Possible remedies:
Air in the system.	Bleed off any air by loosening a pressure line fitting
Possible damage to pump shaft oil seal damaged during assembly	Check seal, and replace if it is necessary
Drive coupling not fitted correctly	Inspect and assemble correctly
Coupling worn	Inspect and replace if necessary
Pump suction with air inside	Check the oil level in the tank and the connections between filter, suction pipe and pump

Trouble observed: <b>High current consumption of the electric motor</b>	
Probable reasons:	Possible remedies:
Motor incorrectly installed	Check correct mounting position if necessary
Low battery charge	Measure, and recharge if necessary
Pump O-Ring or backup ring not fitted correctly	Check, and if necessary replace O-Ring and backup ring.

Trouble observed: <b>Electric motor continues to run even when switched off</b>	
Probable reasons:	Possible remedies:
Wrong electrical connections	Check, and restore proper connections
Starting relay contacts are fuse together as a result of high current.	Disconnect power input immediately and verify condition of the contacts. Replace starter relay if necessary

## 10.5 Example of hydraulic power pack ordering code

1	Type of housing	Vers.	UP50 / K04	
2	Pump	Hi-Lo	Series	AP05 / 0.75 S409
3	Tank	Fitting	Pos.	P-025Q-E P15
4	Suction assembly kit	Tank fixing kit		
5	Electric motor	Pos.	Relay	Pos.
	C240AB/S0	A		
6	Drive	E66		
7	Cavity a	Cavity b	Cavity c	SDF817 / 22 - TH - 23
	Cavity d	Cavity e	Cavity f	15VM01 VRC
	Cavity g	Hand lever	Lever stick	Volt

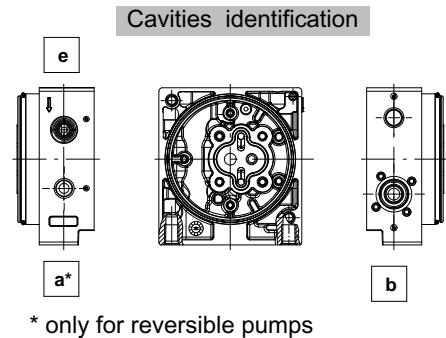

Composition of product code  
 UP50/K04 • AP05/0.75 • S409 P-025Q-E • P15 • C240AB/S0 • A • E66  
 b) SDF817/22-TH -23 • e) 15VM01 • f) VRC  
 Product identification plate example:

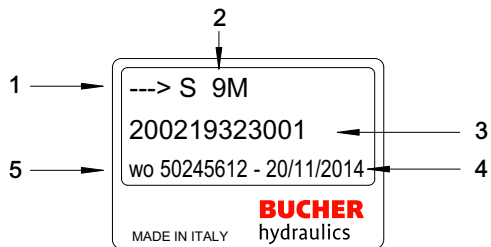

- 1 : Rotation (D= Clockwise rotation - S= Counterclockwise rotation)
- 2 : Manufacturing year and month
- 3 : Bucher Hydraulics S.p.A. product code
- 4 : Date
- 5 : Work order number

Manufacturing month	Manufacturing year						
	2017	2018	2019	2020	2021	2022	2023
January	7A	8M	9M	0M	1M	2M	3M
February	7B	8N	9N	0N	1N	2N	3N
March	7C	8P	9P	0P	1P	2P	3P
April	7D	8Q	9Q	0Q	1Q	2Q	3Q
May	7E	8R	9R	0R	1R	2R	3R
June	7F	8S	9S	0S	1S	2S	3S
July	7G	8T	9T	0T	1T	2T	3T
August	7H	8U	9U	0U	1U	2U	3U
September	7I	8V	9V	0V	1V	2V	3V
October	7J	8Z	9Z	0Z	1Z	2Z	3Z
November	7K	8X	9X	0X	1X	2X	3X
December	7L	8Y	9Y	0Y	1Y	2Y	3Y







[info.it@bucherhydraulics.com](mailto:info.it@bucherhydraulics.com)

[www.bucherhydraulics.com](http://www.bucherhydraulics.com)

© 2019 by Bucher Hydraulics S.p.A, I-42124 Reggio Emilia

All rights reserved.

Data is provided for the purpose of product description only, and must not be construed as warranted characteristics in the legal sense. The information does not relieve users from the duty of conducting their own evaluations and tests. Because the products are subject to continual improvement, we reserve the right to amend the product specifications contained in this catalogue.

Classification: 440.405.000