

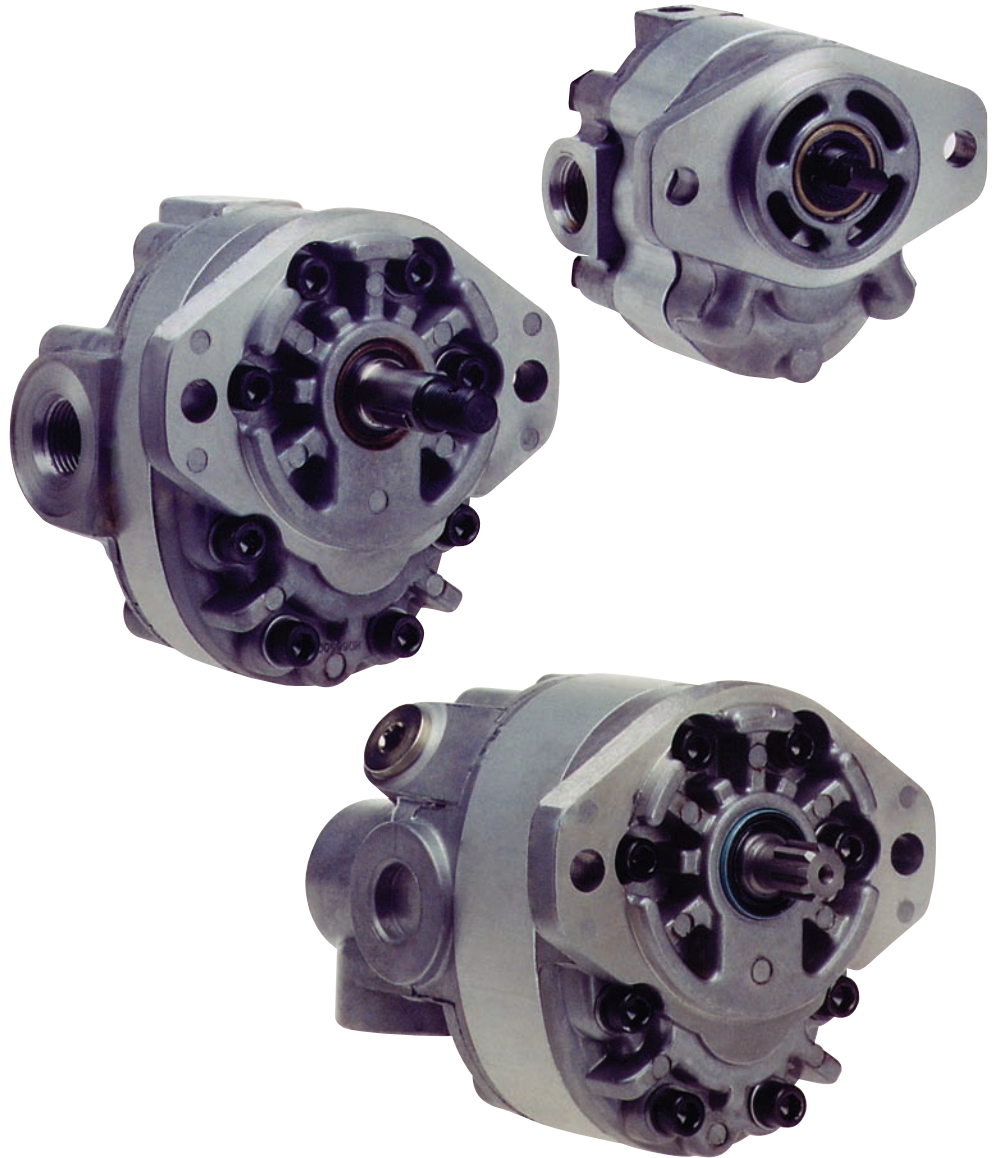

aerospace
climate control
electromechanical
filtration
fluid & gas handling
hydraulics
pneumatics
process control
sealing & shielding



Fixed Displacement Gear Pumps

D/H/HD Series



Table of Contents

Description	Page No.	
Introduction	3	“HD” Series
General Description	4	Ordering Information. 24
“D” Series		Technical Information
Ordering Information.	5	25-27
Technical Information	6-9	Fluid Recommendations..... 28
Dimensions	10-13	Instructions for Reversing
Dimensions - Accessories	14	Gear Pump Rotation
		29
“H” Series		Offer of Sale
Ordering Information.	15-16	30
Technical Information	17-20	
Dimensions	21-22	
Dimensions - Shaft Configuration	23	

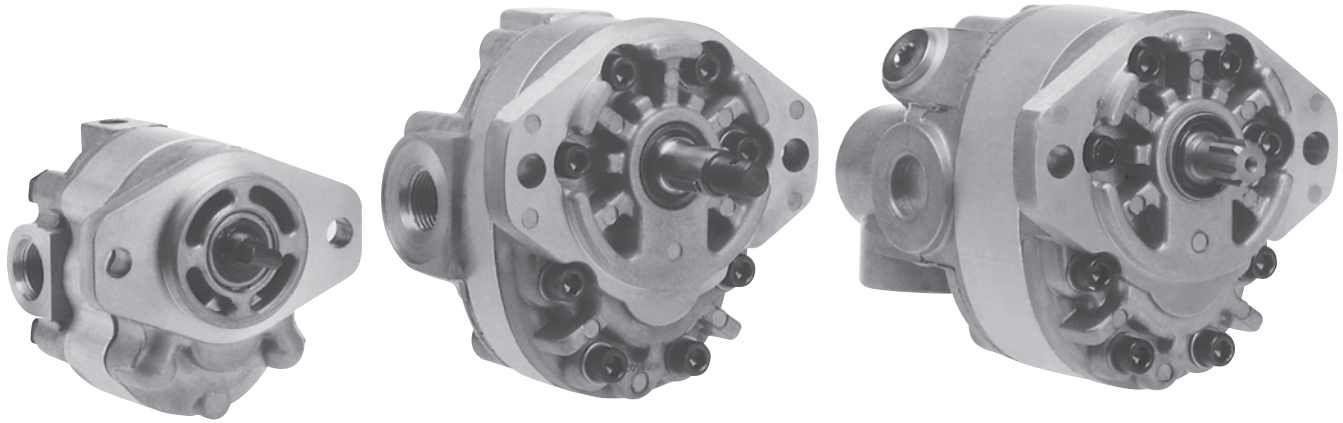
**Quick Reference Data Chart**

Pump Series	Displacement IN ³ /REV. (CC/REV.)	Pump Delivery @ 1000 RPM In GPM (LPM)	Weight In Pounds (Kg)
D	.114 - .641 (1.87 - 10.50)	.5 - 2.7 (1.9 - 10.2)	2 - 3 (.9 - 1.4)
H	.603 - 2.227 (9.88 - 36.50)	2.5 - 9.3 (9.5 - 35.2)	5 - 7 (2.3 - 3.2)
HD	See above	See above	See above

Features

- Pressure-loaded design
- Efficient, simple design - few moving parts
- Exceptionally compact and lightweight for their capacity
- Efficient at high pressure operation
- Resistant to cavitation effects
- High tolerance to system contamination
- Reliable under cold weather operation
- Sleeve-bearing construction
- Multi-fluid compatibility

Pressure capabilities

- D - to 2500 PSI (172 Bar) continuous
- H - to 2500 PSI (172 Bar) continuous
- HD - to 2500 PSI (172 Bar) continuous

Controls

- Optional built-in relief valve on "D" series
- Optional built-in relief valve on "H" series
- Optional built-in relief valve, and flow divider on "H" series
- Special controls (Consult Technical Services)

Speed capabilities

- D - to 4000 RPM
- H - to 4000 RPM
- HD - to 4000 RPM

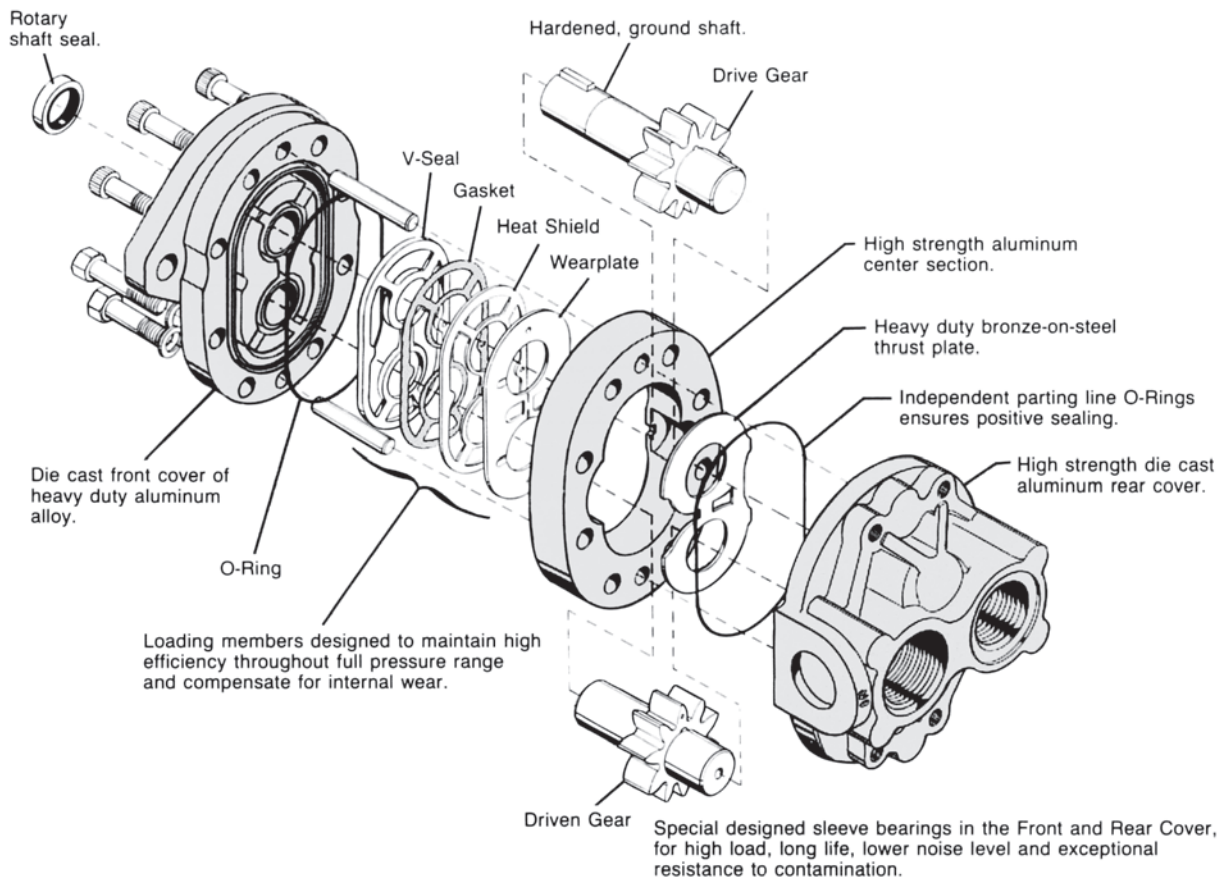

A Parker pressure-loaded gear pump consists of two, intermeshing, hardened-steel, precision-ground gear assemblies. These precision gears are enclosed by a high-strength, die-cast aluminum front cover, back cover and a high-yield, strength-extruded aluminum center section.

Gear assemblies consist of one drive gear, shrink-fitted on a precision-ground and polished drive shaft. This shaft extends outside the pump to permit coupling to an external prime mover. The second gear, being the driven gear, is also shrink-fitted on a precision-ground and polished driven shaft. Retaining rings, which are installed in grooves provided on the shaft, ensure that the gears will not move axially, and a key keeps the drive gear from moving radially.

A lip-type, shaft seal is provided at the drive shaft to prevent external leakage of pump fluid. The sealing lip in contact with the fluid is spring-loaded. Vent passages within the housings and driven shaft communicate pump inlet pressure to the rotary seal area, thus imposing the lowest possible pressure at the rotary seal for extended seal life.

The phenolic heat shield, backup gasket, and molded rubber seal form chambers behind the steel-backed bronze wearplate. These chambers are connected either to inlet or discharge pressure. Discharge pressure, acting within the chambers, axially loads and deflects the wear plate toward the gear faces to take up gear side clearances. This pressure-loading on the wear plate increases pump efficiency by reducing internal leakage to a minimum, providing longer pump life.

Pump rotation is dependent upon the proper orientation of the heat shield, backup gasket, and rubber seal in the front cover housing, the center section and rear cover, respectively.

Pumping action is achieved by connecting the pump drive shaft to a prime mover, and rotating the gears away from the inlet port. Rotation causes the gear mesh to increase on the inlet side and decrease on the outlet (pressure) side.

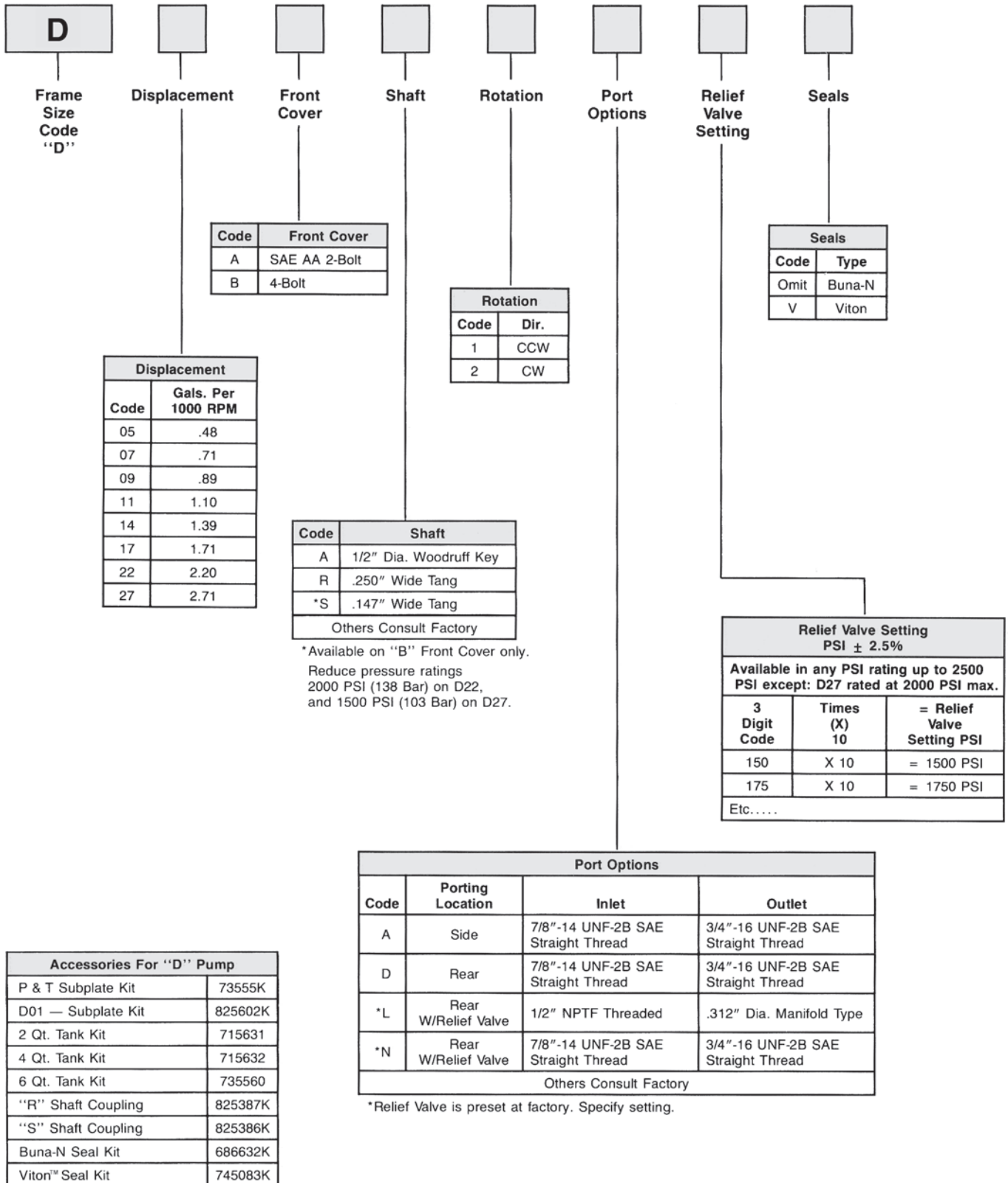

Performance Data

Series D Fixed Displacement, Pressure-Loaded Gear Pump

Features

- Pressure-loaded design
- Efficient, simple design - few moving parts
- Exceptionally compact and lightweight for their capacity
- Efficient at high pressure operation
- Resistant to cavitation effects
- High tolerance to system contamination
- Reliable under cold weather operation
- Sleeve-bearing construction
- Multi-fluid compatibility

Controls

- Optional built-in relief valve
- Consult factory for special controls

Specifications

Flow Ratings:

.5 GPM (1.9 LPM) to 2.7 GPM (10.2 LPM)
(At 1000 RPM) See next page for additional flow data.

Pressure Ratings:

D05 thru D22 - 2500 PSI (172 Bar) continuous
D27 - 2000 PSI (138 Bar) continuous

Speed Ratings:

D05 thru D22 - 500 to 4000 RPM
D27 - 3000 RPM

Mounting:

SAE-AA - 2-Bolt Flange
4-Bolt Flange

Housing Material:

Die-Cast Aluminum

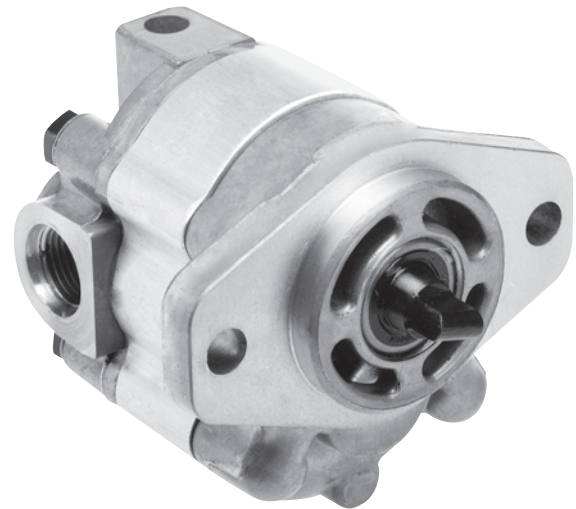

Schematic Symbol

(Basic Pump)



Installation Data

Inlet Conditions:

10 in. hg. max. vacuum condition
(At 1800 RPM)
5 in. hg. max. vacuum condition
(At max. RPM)
20 PSI (1.4 Bar) max. positive pressure

Operating Temperature Range:

-40°F to 185°F
(-40°C to 85°C)

Filtration:

Maintain SAE Class 4

Installation Note:

See page 28 for specific recommendations pertaining to system cleanliness, fluids, start-up, inlet conditions, shaft alignment, and other important factors relative to the proper installation and use of these pumps.

Performance Data

Data Based on 100 SSU
Viscosity Fluids at 120°F (49°C)

Flow in Gallons Per Minute – GPM (LPM)

Pump Model	Displacement IN ³ (CC/REV.)	RPM	100 PSI (6.9 Bar)	1000 PSI (69 Bar)	1500 PSI (103 Bar)	2000 PSI (138 Bar)	2500 PSI (172 Bar)
D05	.114 (1.87)	1200	.58 (2.20)	.48 (1.82)	.42 (1.59)	.37 (1.40)	.32 (1.21)
		1800	.87 (3.30)	.77 (2.92)	.71 (2.69)	.66 (2.50)	.61 (2.31)
		3600	1.73 (6.56)	1.65 (6.25)	1.61 (6.10)	1.56 (5.91)	1.52 (5.76)
D07	.168 (2.76)	1200	.85 (3.22)	.73 (2.77)	.68 (2.58)	.62 (2.35)	.56 (2.12)
		1800	1.28 (4.85)	1.16 (4.40)	1.10 (4.17)	1.05 (3.98)	.99 (3.75)
		3600	2.56 (9.70)	2.47 (9.36)	2.42 (9.17)	2.37 (8.98)	2.33 (8.83)
D09	.210 (3.45)	1200	1.06 (4.02)	.94 (3.56)	.87 (3.30)	.81 (3.07)	.75 (2.84)
		1800	1.60 (6.06)	1.48 (5.61)	1.41 (5.34)	1.35 (5.12)	1.29 (4.89)
		3600	3.19 (12.09)	3.09 (11.71)	3.04 (11.52)	2.99 (11.33)	2.94 (11.14)
D11	.262 (4.29)	1200	1.32 (5.00)	1.19 (4.51)	1.12 (4.24)	1.06 (4.02)	.99 (3.75)
		1800	1.99 (7.54)	1.86 (7.05)	1.79 (6.78)	1.73 (6.56)	1.66 (6.29)
		3600	3.97 (15.05)	3.86 (14.63)	3.81 (14.44)	3.76 (14.25)	3.70 (14.02)
D14	.329 (5.38)	1200	1.66 (6.29)	1.52 (5.76)	1.44 (5.46)	1.37 (5.19)	1.30 (4.92)
		1800	2.49 (9.44)	2.35 (8.91)	2.27 (8.60)	2.20 (8.34)	2.13 (8.07)
		3600	4.99 (18.91)	4.88 (18.50)	4.82 (18.27)	4.76 (18.04)	4.70 (17.81)
D17	.404 (6.62)	1200	2.04 (7.73)	1.88 (7.13)	1.80 (6.82)	1.72 (6.52)	1.64 (6.22)
		1800	3.07 (11.64)	2.91 (11.03)	2.83 (10.73)	2.75 (10.42)	2.67 (10.12)
		3600	6.14 (23.27)	6.01 (22.78)	5.95 (22.55)	5.88 (22.29)	5.82 (22.06)
D22	.522 (8.55)	1200	2.64 (10.00)	2.46 (9.32)	2.37 (8.98)	2.28 (8.64)	2.19 (8.30)
		1800	3.97 (15.05)	3.79 (14.36)	3.70 (14.02)	3.61 (13.68)	3.52 (13.34)
		3600	7.93 (30.05)	7.79 (29.52)	7.71 (29.22)	7.64 (28.96)	7.57 (28.69)
D27	.641 (10.50)	1200	3.25 (12.32)	3.05 (11.56)	2.95 (11.18)	2.85 (10.80)	---
		1800	4.87 (18.46)	4.67 (17.70)	4.57 (17.32)	4.47 (16.94)	---
		3000	8.12 (30.77)	7.96 (30.17)	7.88 (29.86)	7.80 (29.56)	---

Performance Data

**Based On Oil Temperature of 120°F (49°C)
 (100 SSU) Atmospheric Inlet**

D05/D07 Horsepower/Speed

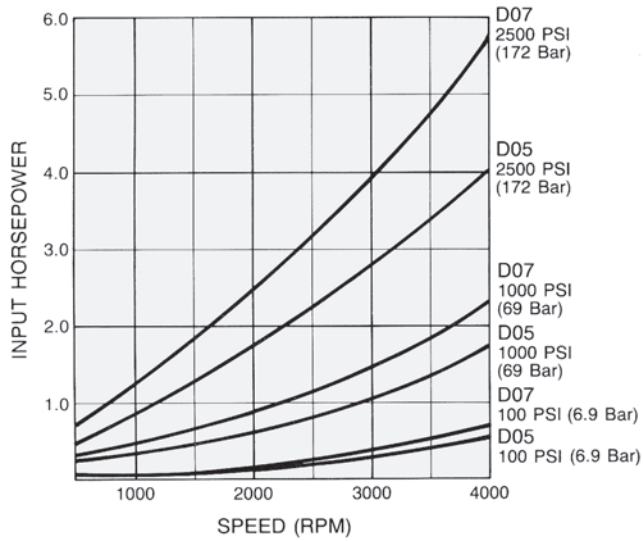

D05/D07 Flow/Speed

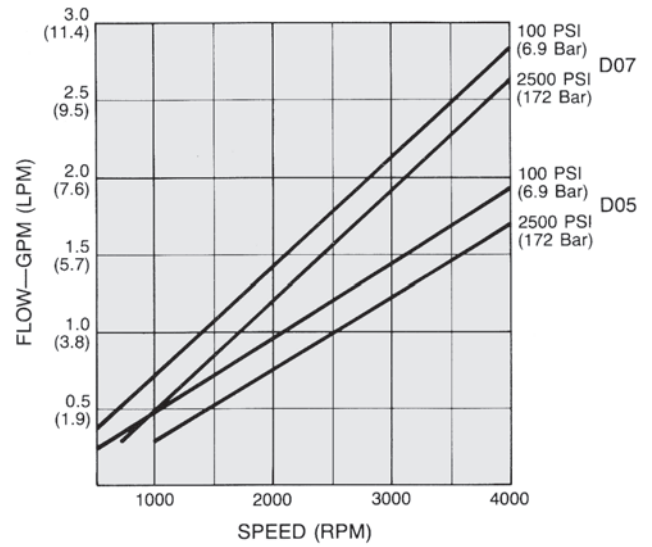

D09/D11 Horsepower/Speed

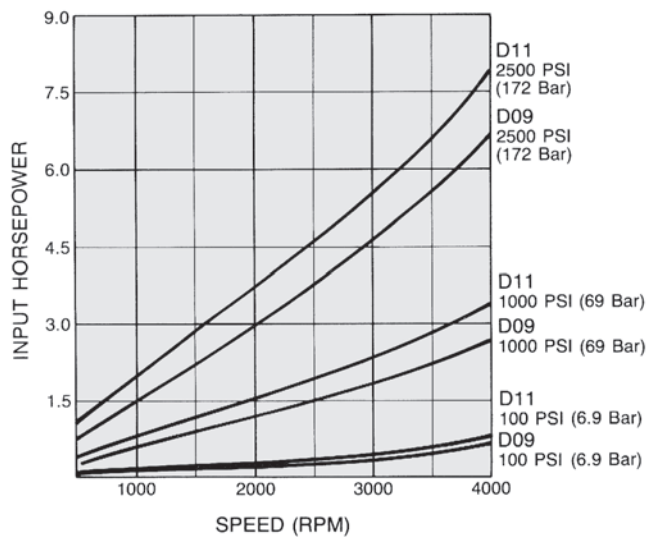

D09/D11 Flow/Speed

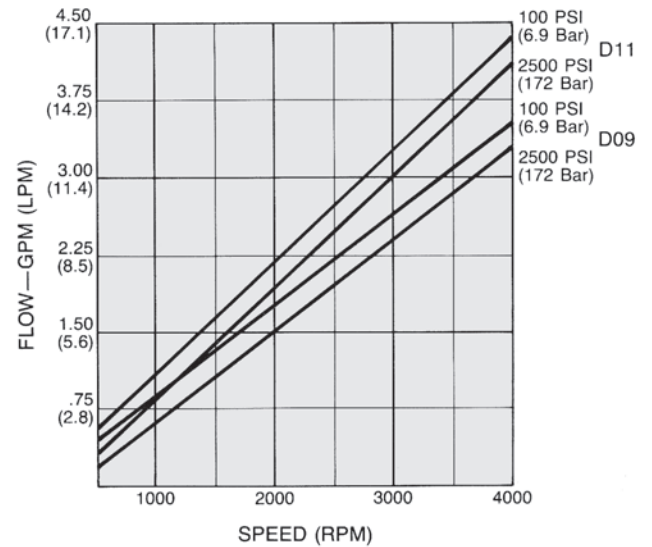

Performance Data

Based On Oil Temperature of 120°F (49°C)
 (100 SSU) Atmospheric Inlet

D14/D17 Horsepower/Speed

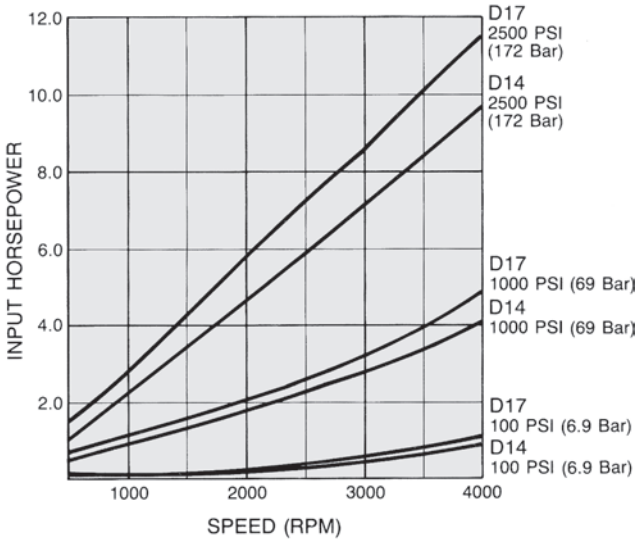

D14/D17 Flow/Speed

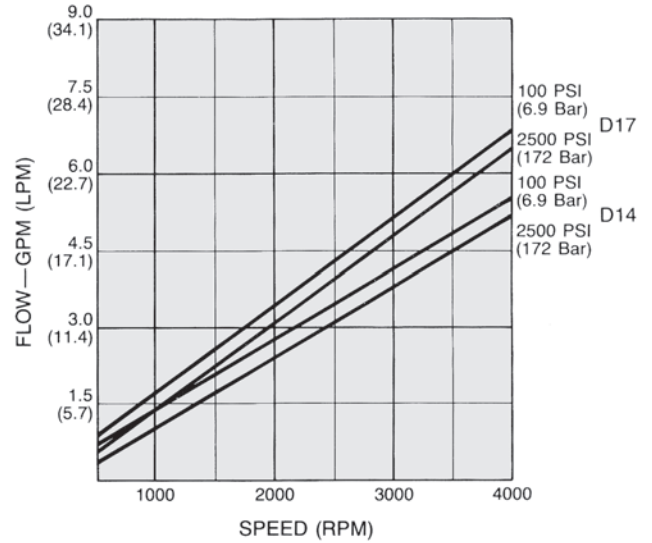

D22/D27 Horsepower/Speed

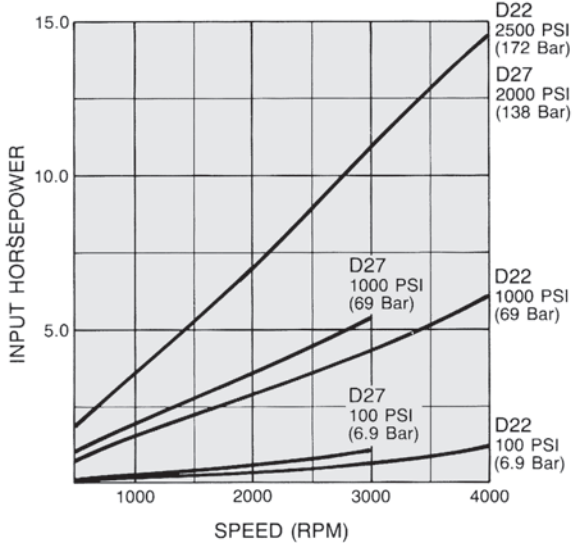

D22/D27 Flow/Speed

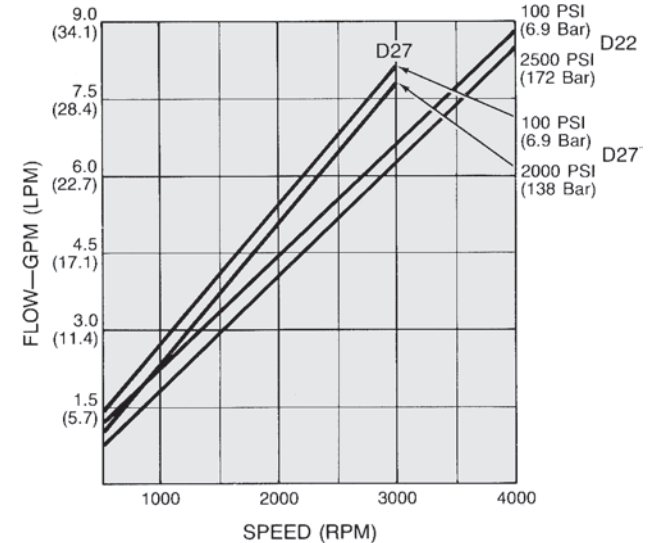

Dimensions – 2-Bolt Mounting

Clockwise rotation and “A” shaft shown
 (Port locations reverse for CCW rotation)

Dimensions: Inches (mm)

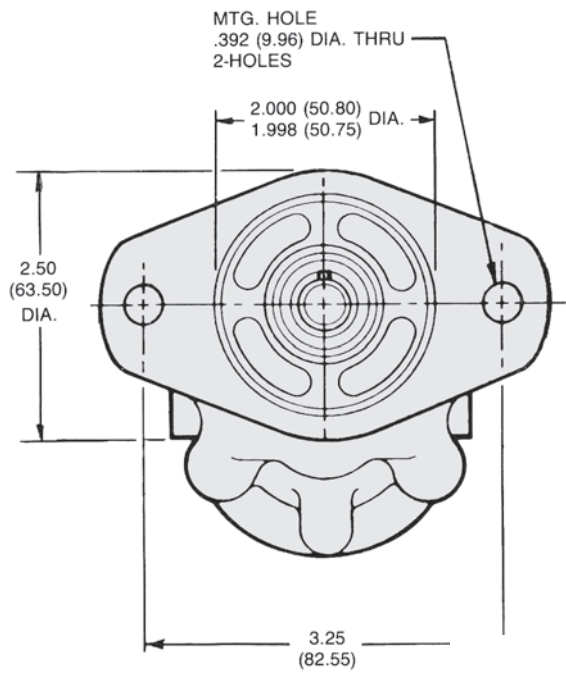

Front View

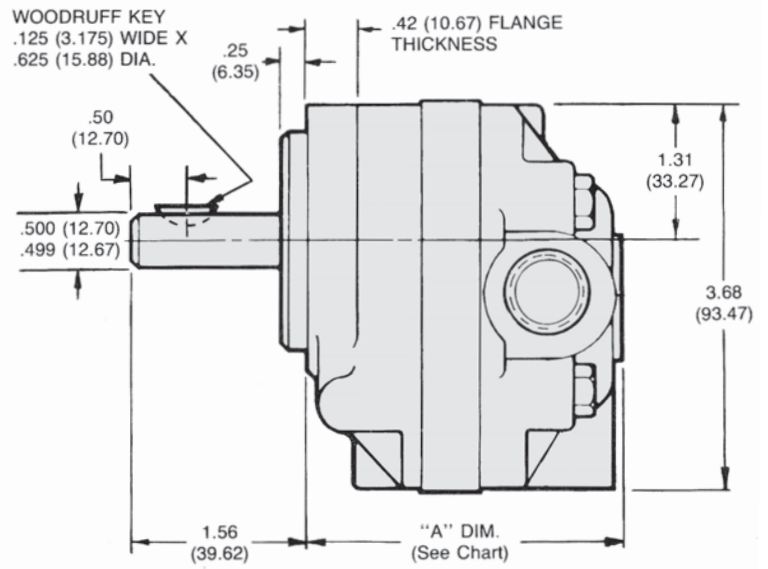

Side View

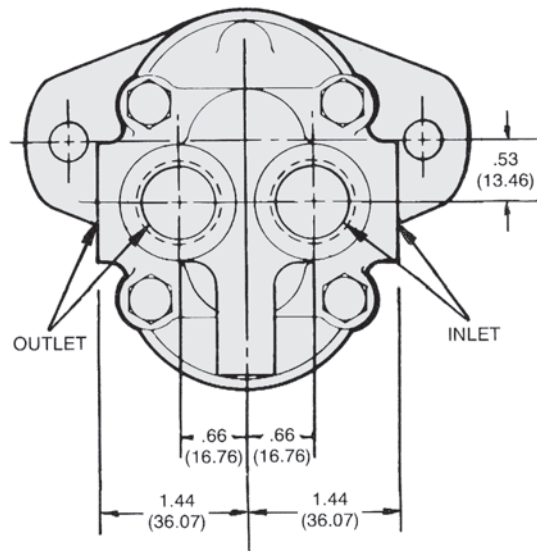

Rear View

“A” Dimensions: Inches (mm)

D05	D07	D09	D11	D14	D17	D22	D27
2.48 (62.99)	2.57 (65.28)	2.64 (67.06)	2.72 (69.09)	2.83 (71.88)	2.96 (75.18)	3.15 (80.01)	3.34 (84.84)

Dimensions

Dimensions – 4-Bolt Mounting

Clockwise rotation and “A” shaft shown
(Port locations reverse for CCW rotation.)

Dimensions: Inches (mm)

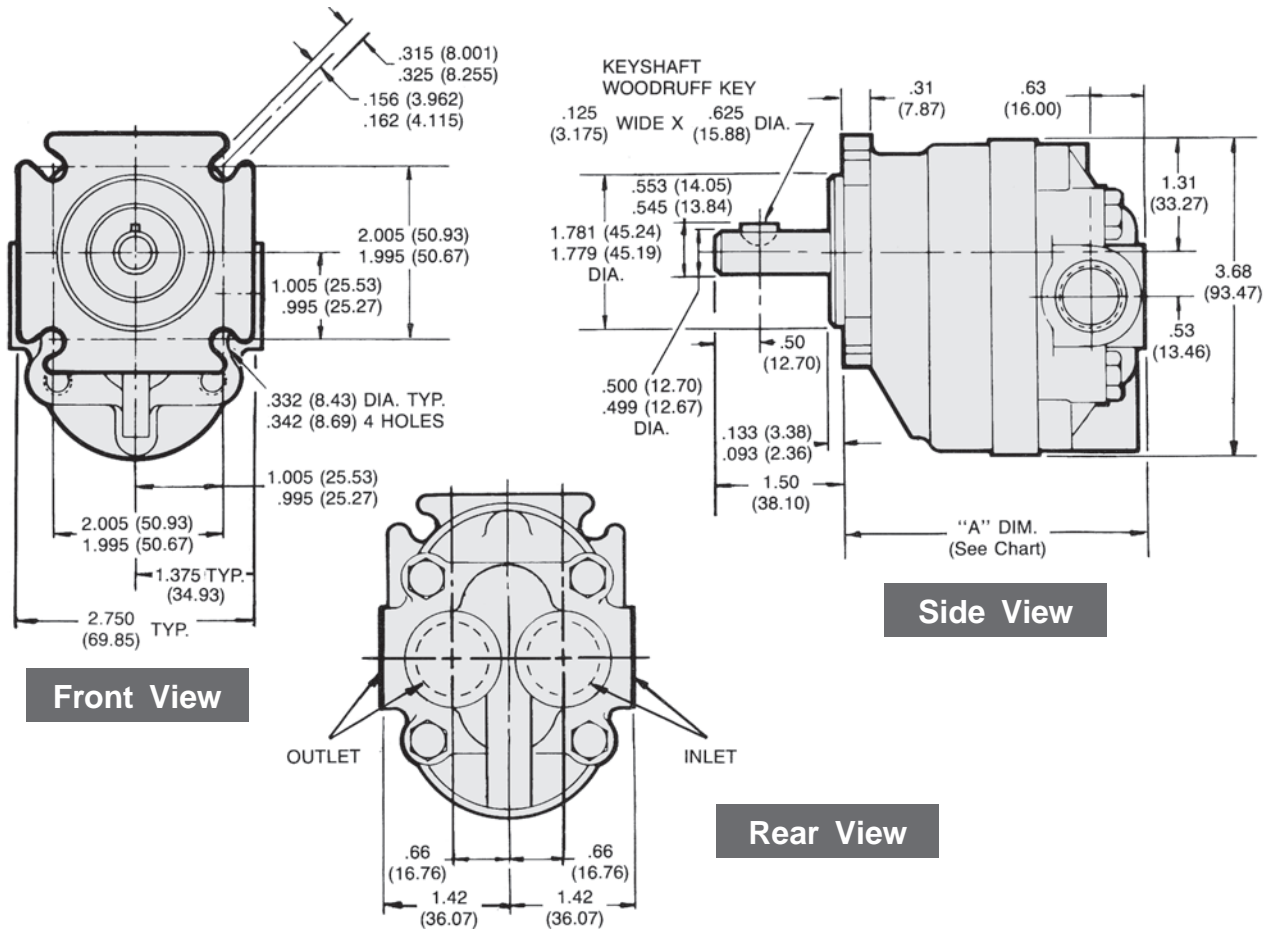

“A” Dimensions: Inches (mm)

D05	D07	D09	D11	D14	D17	D22	D27
3.22 (81.79)	3.31 (84.07)	3.38 (85.85)	3.47 (88.14)	3.58 (90.93)	3.70 (93.98)	3.90 (99.06)	4.09 (103.89)

“S” Tang-end Shaft Option – For Use With 4-Bolt Mounting

Primarily used to direct-couple to electric motor drive.

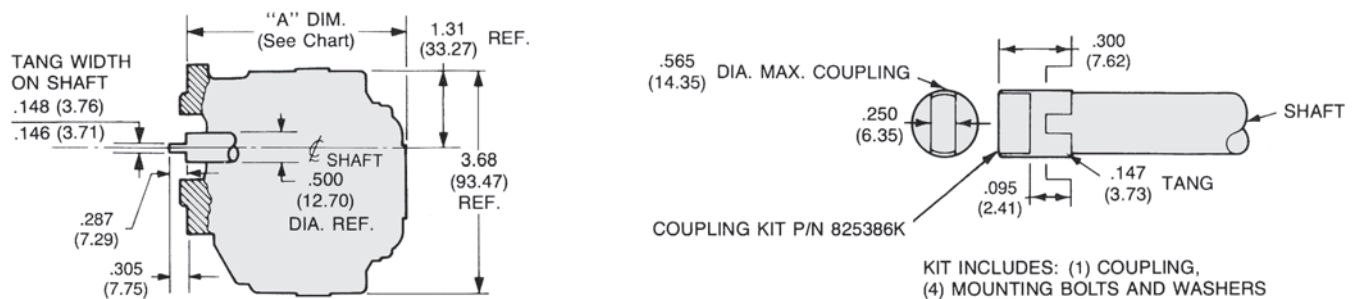

**Dimensions – 2-Bolt Mounting
 (With “L” Back Cover For Tank Mounting)**

Clockwise rotation and “A” shaft shown
 (Pump mounting flange opposite side of back cover
 centerline for CW rotation.)

Dimensions: Inches (mm)

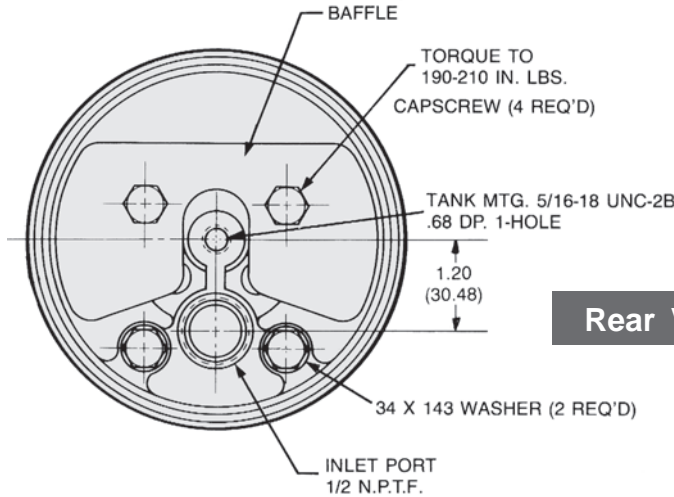
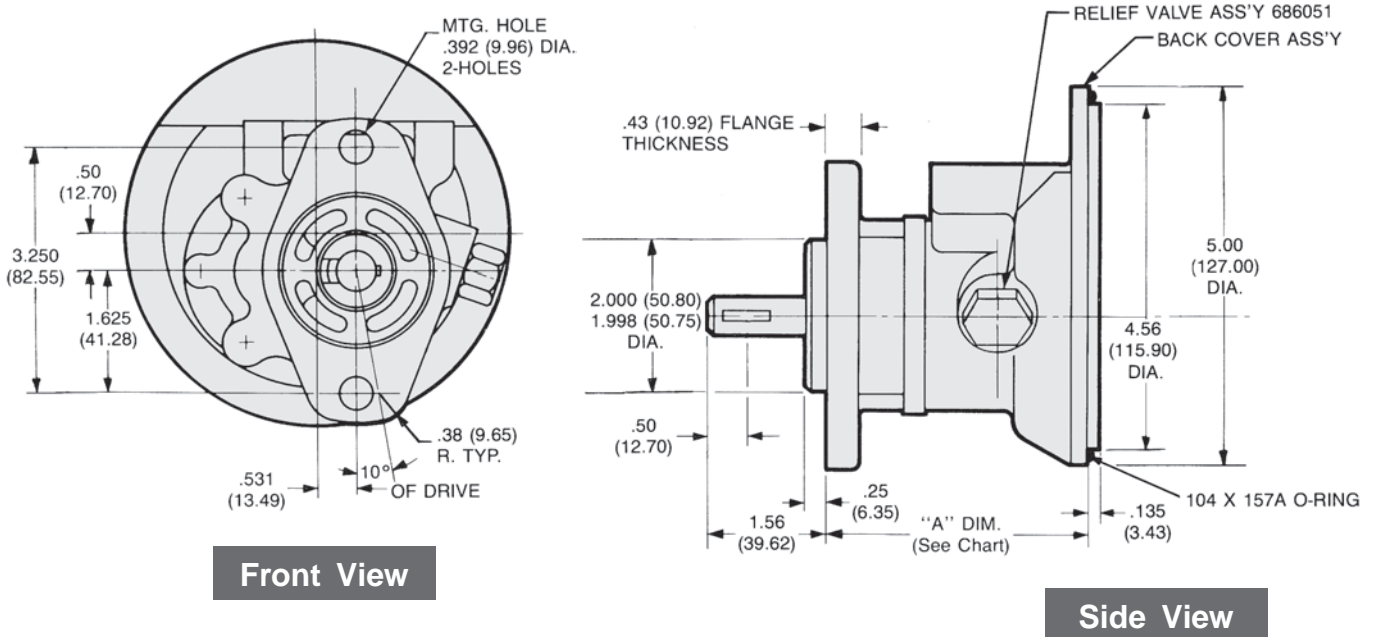

“A” Dimensions: Inches (mm)

D05	D07	D09	D11	D14	D17	D22	D27
3.39 (86.11)	3.48 (88.39)	3.55 (90.17)	3.64 (92.46)	3.75 (95.25)	3.87 (98.30)	4.06 (103.12)	4.26 (108.20)

**Dimensions – 4-Bolt Mounting
 (With “L” Back Cover For Tank Mounting)**

Clockwise rotation and “A” shaft shown
 (Pump mounting flange opposite side of back cover
 centerline for CW rotation.)

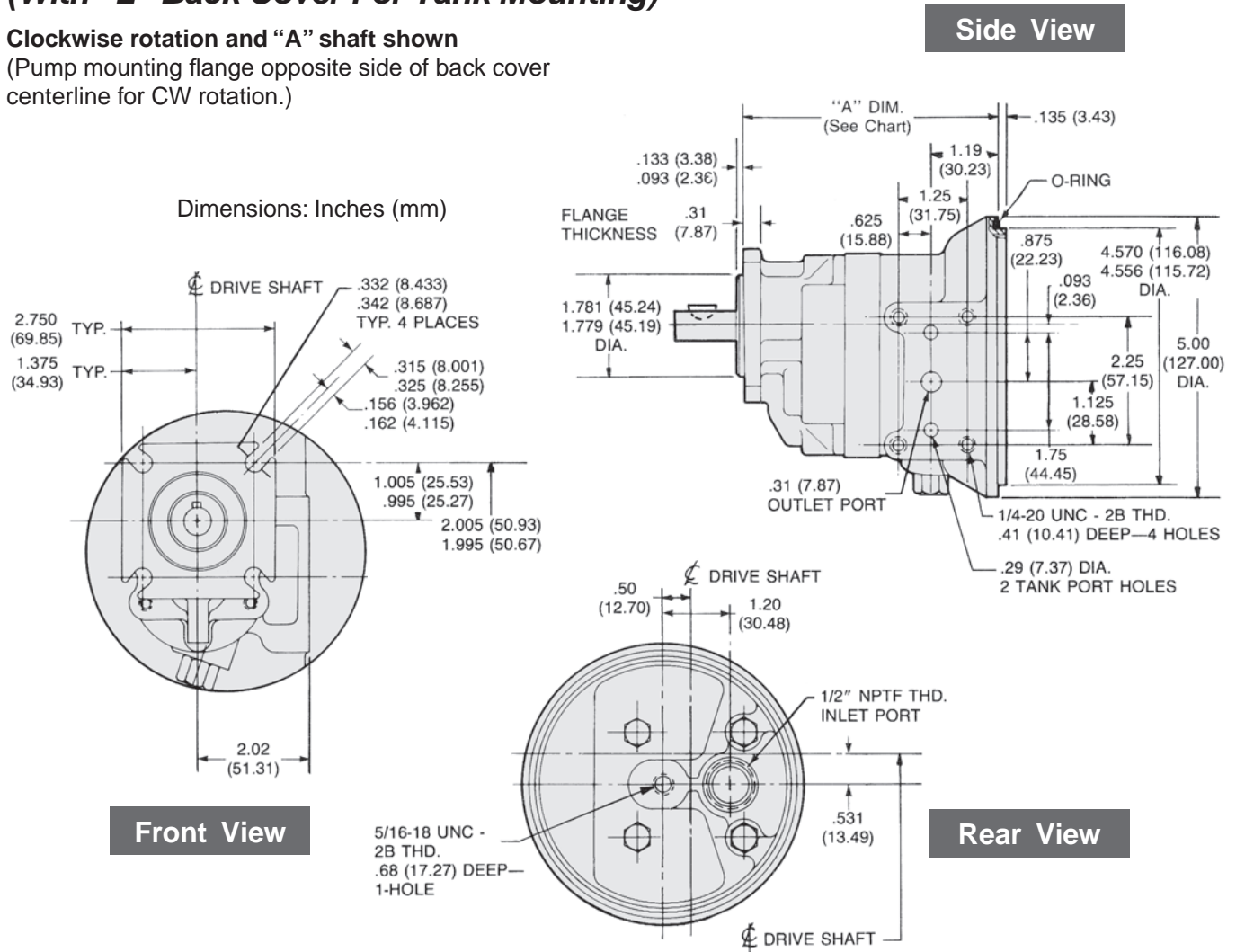

“A” Dimensions: Inches (mm)

D05	D07	D09	D11	D14	D17	D22	D27
4.14 (105.16)	4.23 (107.44)	4.30 (109.22)	4.39 (111.51)	4.50 (114.30)	4.62 (117.35)	4.81 (122.17)	5.01 (127.25)

“R” Tang-end Shaft Option

Primarily used to direct-couple to electric motor drives.

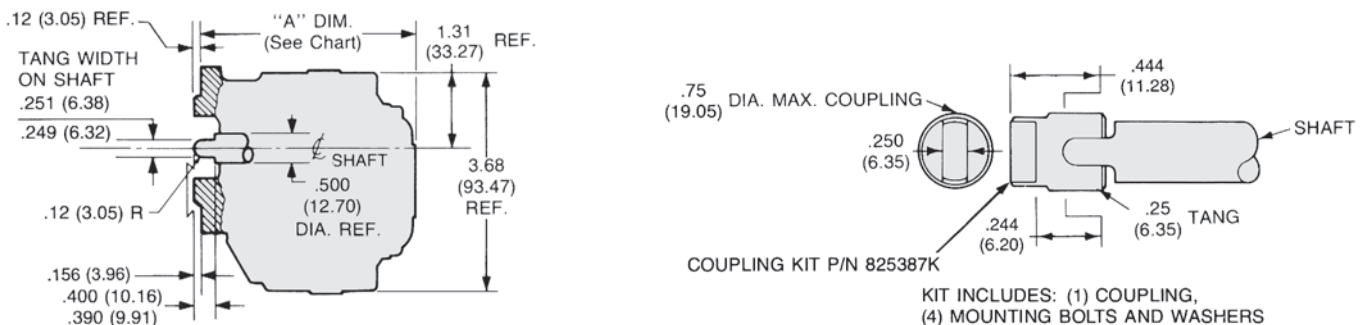

**Dimensions – Accessories For “L”
 Back Cover Pump**

**Sub-plate for supply, return and gage ports –
 Kit no. 735555K**

Dimensions: Inches (mm)

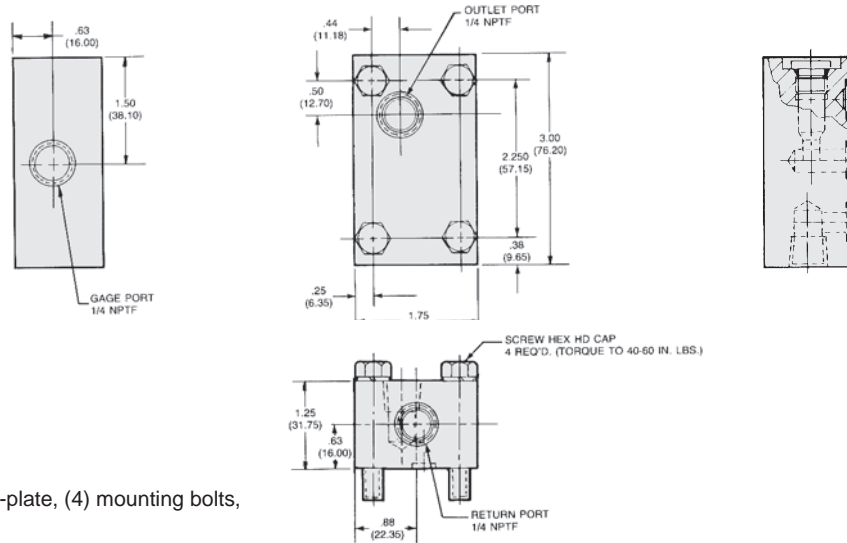

Note: Kit includes (1) sub-plate, (4) mounting bolts,
 (3) O-rings, (1) plug.

**Sub-Plate For Mounting (NFPA D01)
 Directional Control Valve – Kit No. 825602K**

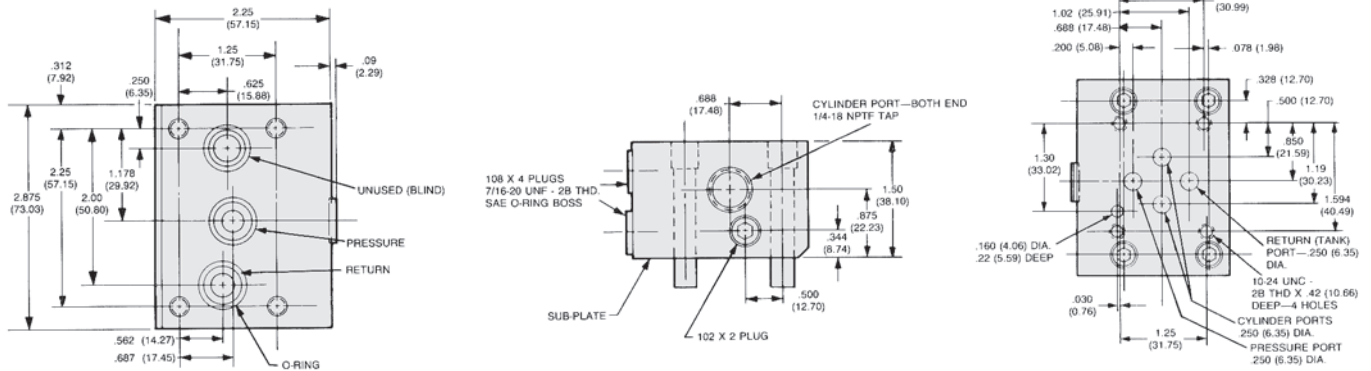

Note: Kit includes (1) sub-plate, (4) mounting bolts, (3) O-rings, (1) plug.

Tanks (Hydraulic Reservoir)

2-Quart Capacity Tank - Kit No. 715631

“B” Dimension 4.67 (118.62) inches

4-Quart Capacity Tank - Kit No. 715632

“B” Dimension 10.17 (258.32) inches

6-Quart Capacity Tank - Kit No. 735560

“B” Dimension 14.17 (359.92) inches

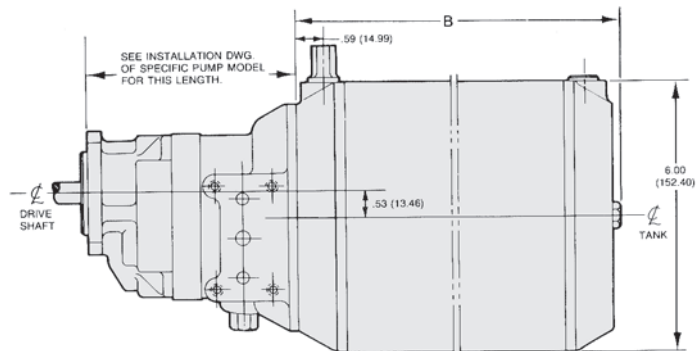

Note: Kit includes- (1) reservoir assembly, (1) suction strainer, (1) filler cap.

Series H Standard Pumps

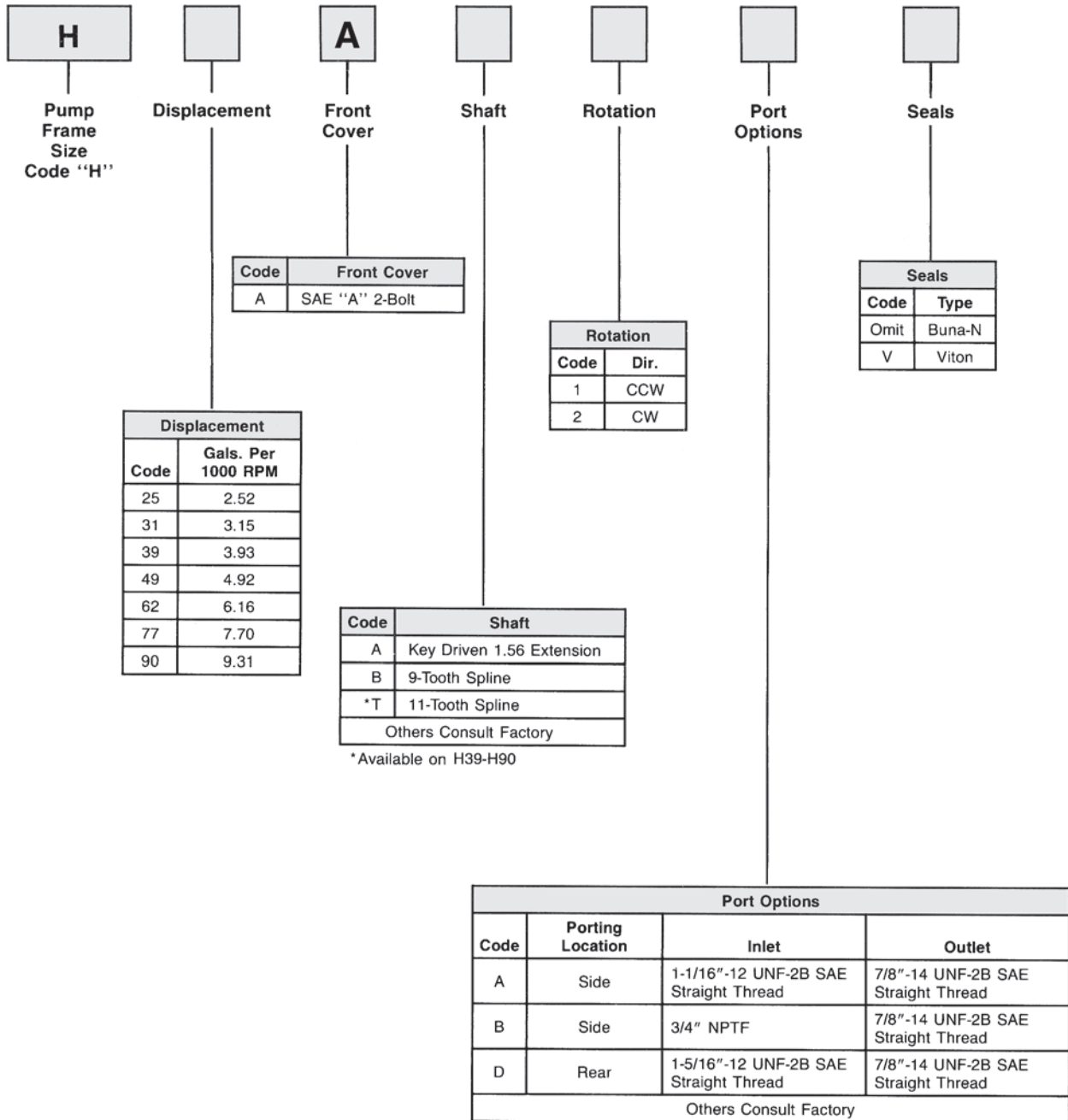

Buna-N Replacement Seal Kit: Order Part No. 706024K

Viton™ Replacement Seal Kit: Order Part No. 745100K

Series H Standard Pumps

Note: Primarily used on "on-road" power steering pump applications.

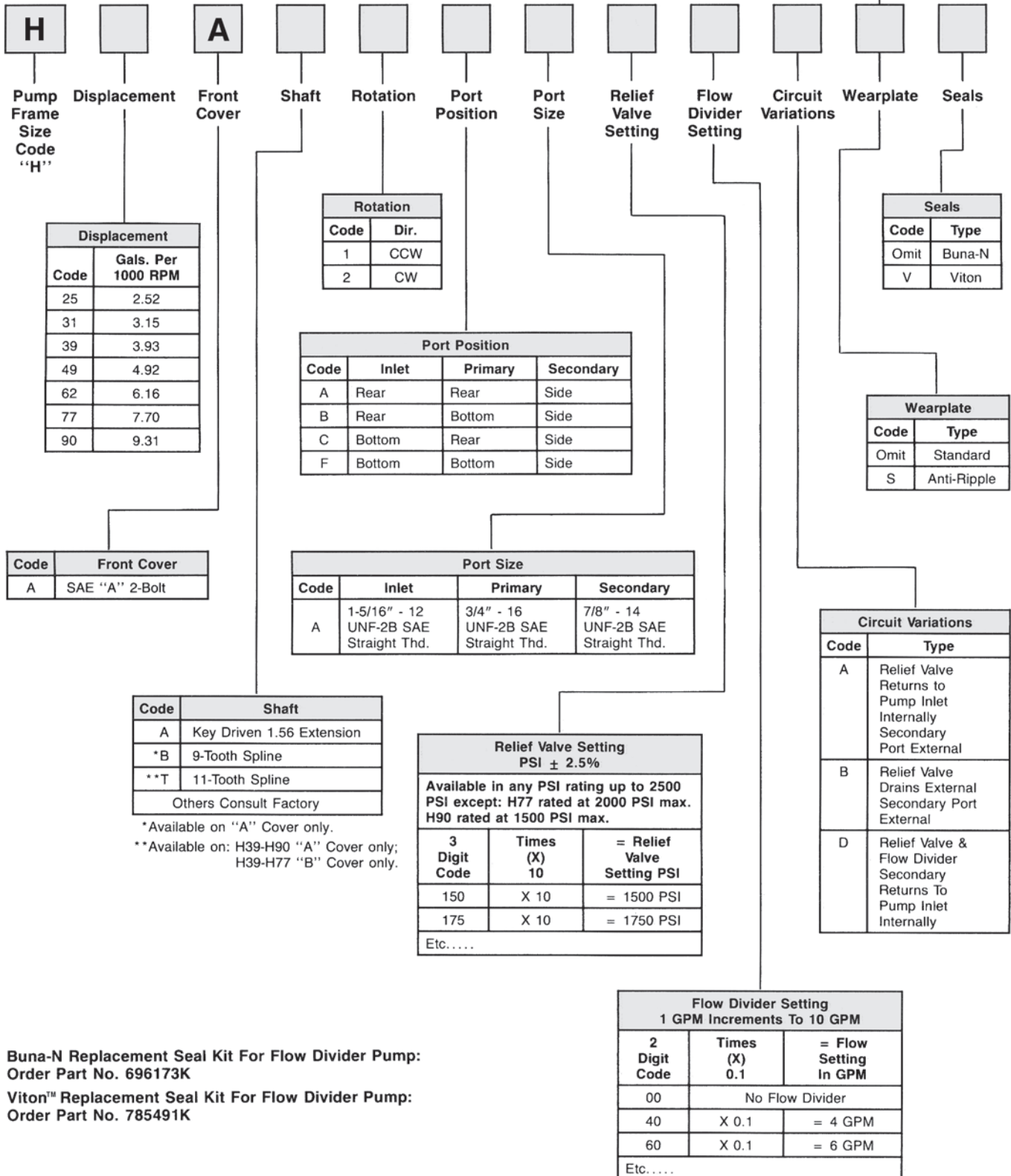

Performance Data

Series H Fixed Displacement, Pressure-Loaded Gear Pump

Features

- Pressure-loaded design
- Efficient, simple design - few moving parts
- Exceptionally compact and lightweight for their capacity
- Efficient at high-pressure operation
- Resistant to cavitation effects
- High tolerance to system contamination
- Reliable under cold weather operation
- Sleeve-bearing construction
- Multi-fluid compatibility

Controls

- Optional built-in relief valve
- Optional built-in relief valve and flow divider
- Special controls (Consult Technical Services)

Specifications

Flow Ratings:

2.5 GPM (9.5 LPM) to 9.3 GPM (35.2 LPM)
(At 1000 RPM) See next page for additional flow data

Pressure Ratings:

H25 thru H62 - 2500 PSI (172 Bar) continuous
H77 - 2000 PSI (138 Bar) continuous
H90 - 1500 PSI (103 Bar) continuous

Speed Ratings:

H25 thru H49 - 500 to 4000 RPM
H62, H77, H90 - 3600 RPM

Mounting:

SAE-A - 2-Bolt Flange
Optional SAE-A - 2-Bolt Flange
Extended Front Cover

Housing Material:

Die-Cast Aluminum

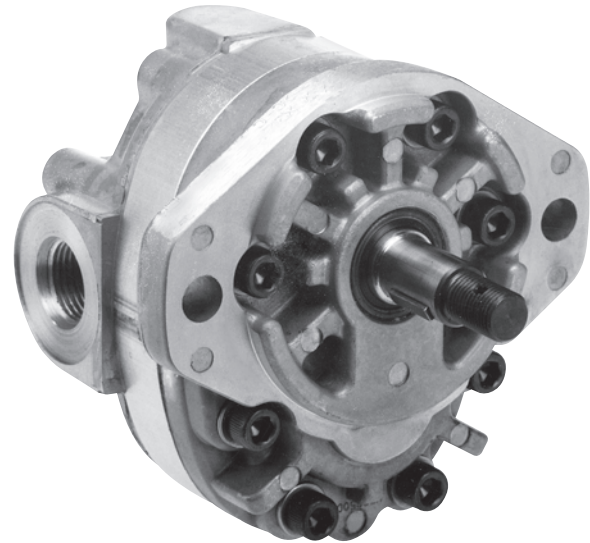

Schematic Symbol

(Basic Pump)



Installation Data

Inlet Conditions:

10 in. hg. max. vacuum condition (at 1800 RPM)
5 in. hg. max. vacuum condition (at max. RPM)
20 PSI (1.4 Bar) max. positive pressure

Operating Temperature Range:

-40°F to 185°F (-40°C to 85°C)

Filtration:

Maintain SAE Class 4

Installation Note:

See page 28 for specific recommendations pertaining to system cleanliness, fluids, start-up, inlet conditions, shaft alignment, and other important factors relative to the proper installation and use of these pumps.

Performance Data

Data Based on 100 SSU
Viscosity Fluids at 120°F (49°C)

Flow In Gallons Per Minute — GPM (LPM)

Pump Model	Displacement IN ³ (CC/REV.)	RPM	100 PSI (6.9 Bar)	1000 PSI (69 Bar)	1500 PSI (103 Bar)	2000 PSI (138 Bar)	2500 PSI (172 Bar)
H25	.603 (9.88)	1200	3.02 (11.45)	2.84 (10.76)	2.75 (10.42)	2.66 (10.08)	2.57 (9.74)
		1800	4.54 (17.21)	4.35 (16.49)	4.26 (16.15)	4.17 (15.80)	4.09 (15.50)
		3600	9.07 (34.38)	8.93 (33.84)	8.85 (33.54)	8.78 (33.28)	8.70 (32.97)
H31	.754 (12.35)	1200	3.78 (14.33)	3.58 (13.57)	3.49 (13.23)	3.40 (12.89)	3.30 (12.50)
		1800	5.67 (21.49)	5.48 (20.77)	5.38 (20.39)	5.28 (20.01)	5.19 (19.67)
		3600	11.34 (42.98)	11.19 (42.41)	11.11 (42.11)	11.03 (41.80)	10.96 (41.54)
H39	.942 (15.44)	1200	4.72 (17.89)	4.51 (17.09)	4.41 (16.71)	4.30 (16.30)	4.20 (15.92)
		1800	7.08 (26.83)	6.87 (26.04)	6.77 (25.66)	6.66 (25.24)	6.56 (24.86)
		3600	14.20 (53.82)	14.00 (53.06)	13.90 (52.68)	13.80 (52.30)	13.70 (51.92)
H49	1.178 (19.30)	1200	5.90 (22.36)	5.67 (21.49)	5.56 (21.07)	5.44 (20.61)	5.33 (20.20)
		1800	8.85 (33.54)	8.62 (32.67)	8.51 (32.25)	8.39 (31.80)	8.28 (31.38)
		3600	17.70 (67.08)	17.50 (66.33)	17.40 (65.95)	17.30 (65.57)	17.20 (65.19)
H62	1.473 (24.14)	1200	7.39 (28.01)	7.13 (27.02)	7.00 (26.53)	6.88 (26.08)	6.75 (25.58)
		1800	11.10 (42.07)	10.81 (40.97)	10.70 (40.55)	10.60 (40.17)	10.40 (39.42)
		3600	22.20 (84.14)	22.00 (83.38)	21.90 (83.00)	21.80 (82.62)	21.70 (82.24)
H77	1.842 (30.18)	1200	9.23 (34.98)	8.95 (33.92)	8.81 (33.39)	8.67 (32.86)	---
		1800	13.90 (52.68)	13.60 (51.54)	13.40 (50.79)	13.30 (50.41)	---
		3600	27.70 (104.98)	27.50 (104.23)	27.40 (103.85)	27.20 (103.09)	---
H90	2.227 (36.50)	1200	11.20 (42.45)	10.90 (41.31)	10.80 (40.93)	---	---
		1800	16.70 (63.29)	16.50 (62.54)	16.30 (61.78)	---	---
		3600	33.50 (126.97)	33.20 (125.83)	33.10 (125.45)	---	---

Performance Data

**Based On Oil Temperature of 120°F (49°C)
 (100 SSU) Atmospheric Inlet**

H25/H31 Horsepower/Speed

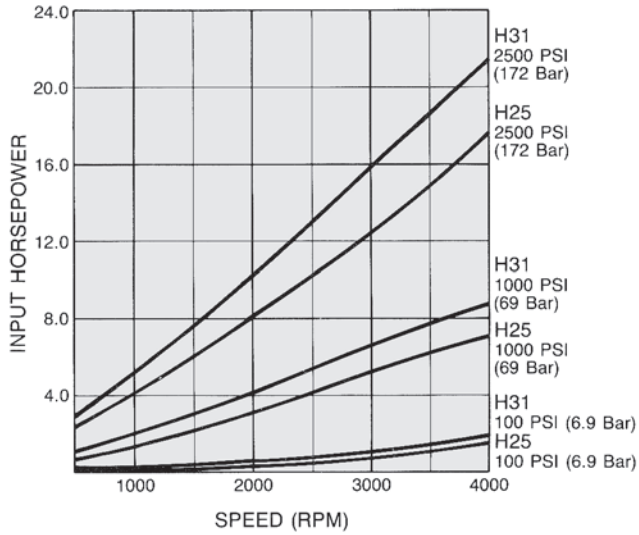

H25/H31 Flow/Speed

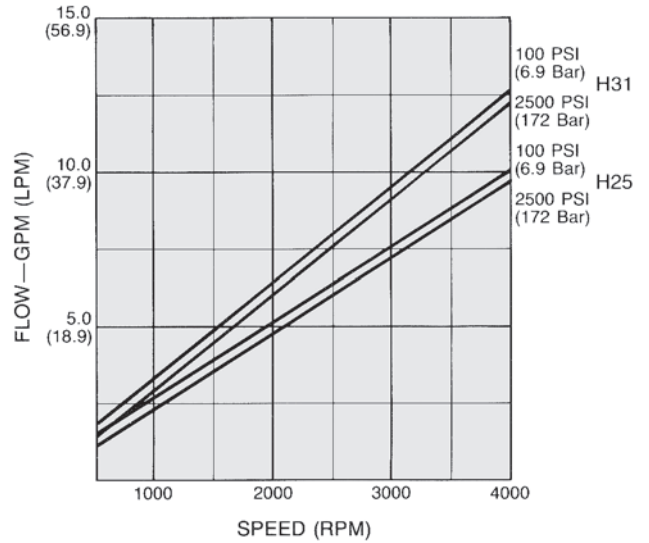

H39/H49 Horsepower/Speed

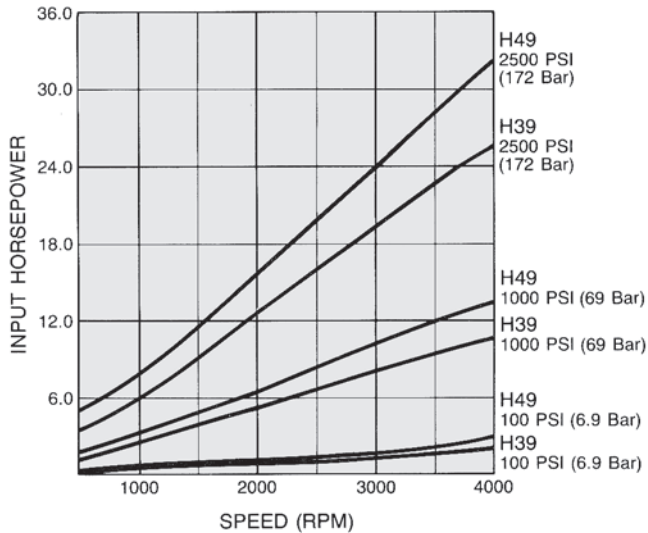

H39/H49 Flow/Speed

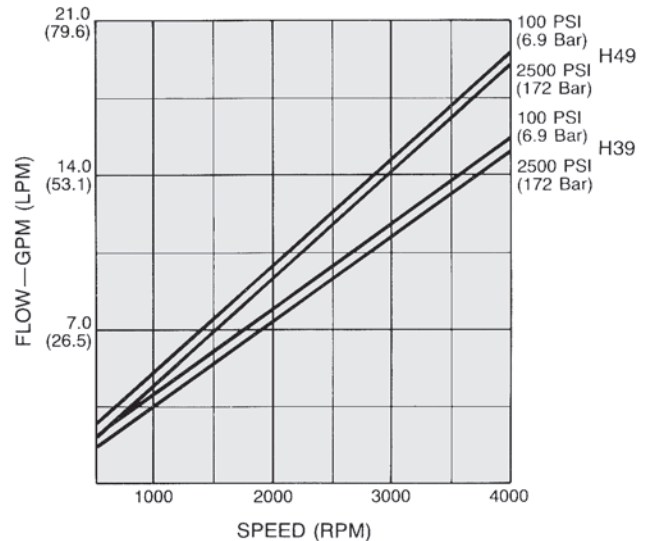

Performance Data

**Based On Oil Temperature of 120°F (49°C)
 (100 SSU) Atmospheric Inlet**

H62/H77 Horsepower/Speed

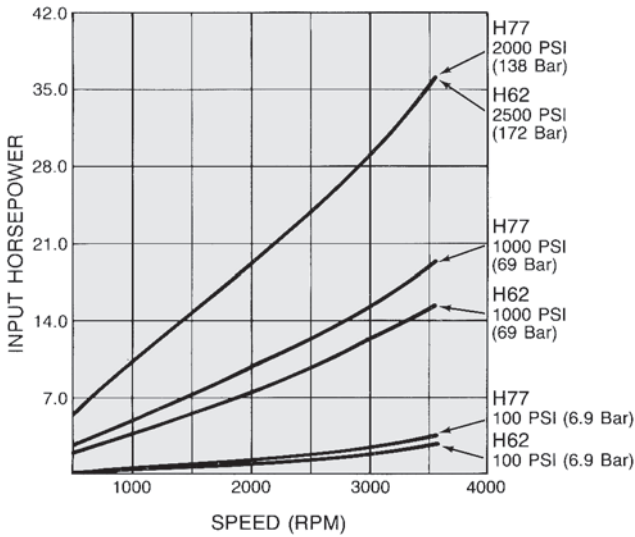

H62/H77 Flow/Speed

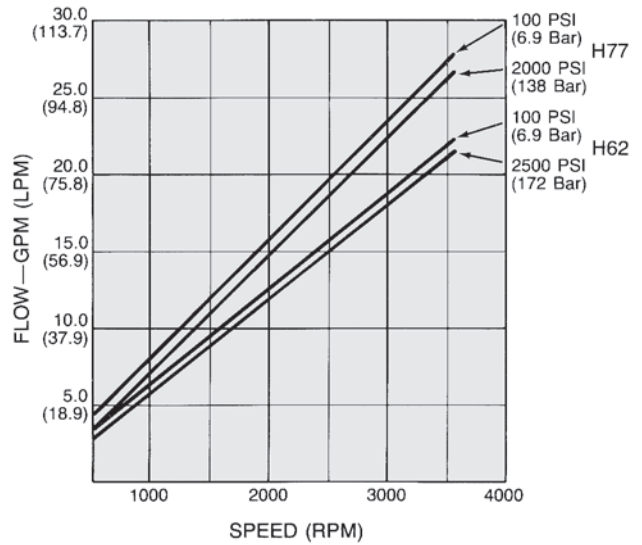

H90 Horsepower/Speed

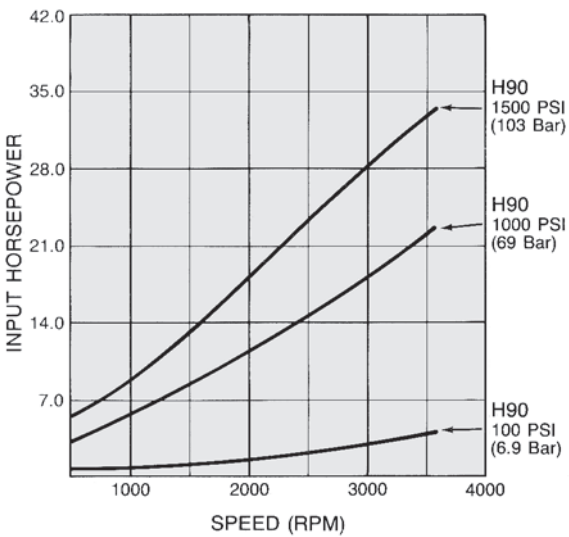

H90 Flow/Speed

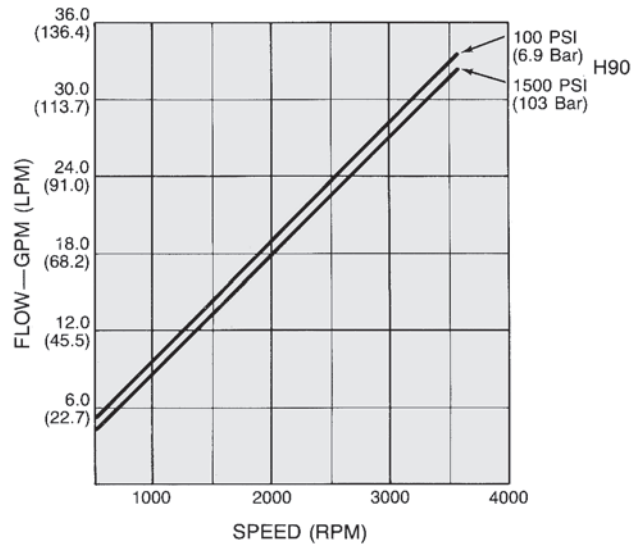

Dimensions – 2-Bolt Mounting

Clockwise rotation and “A” shaft shown
 (Port locations reverse for CCW rotation.)

Dimensions: Inches (mm)

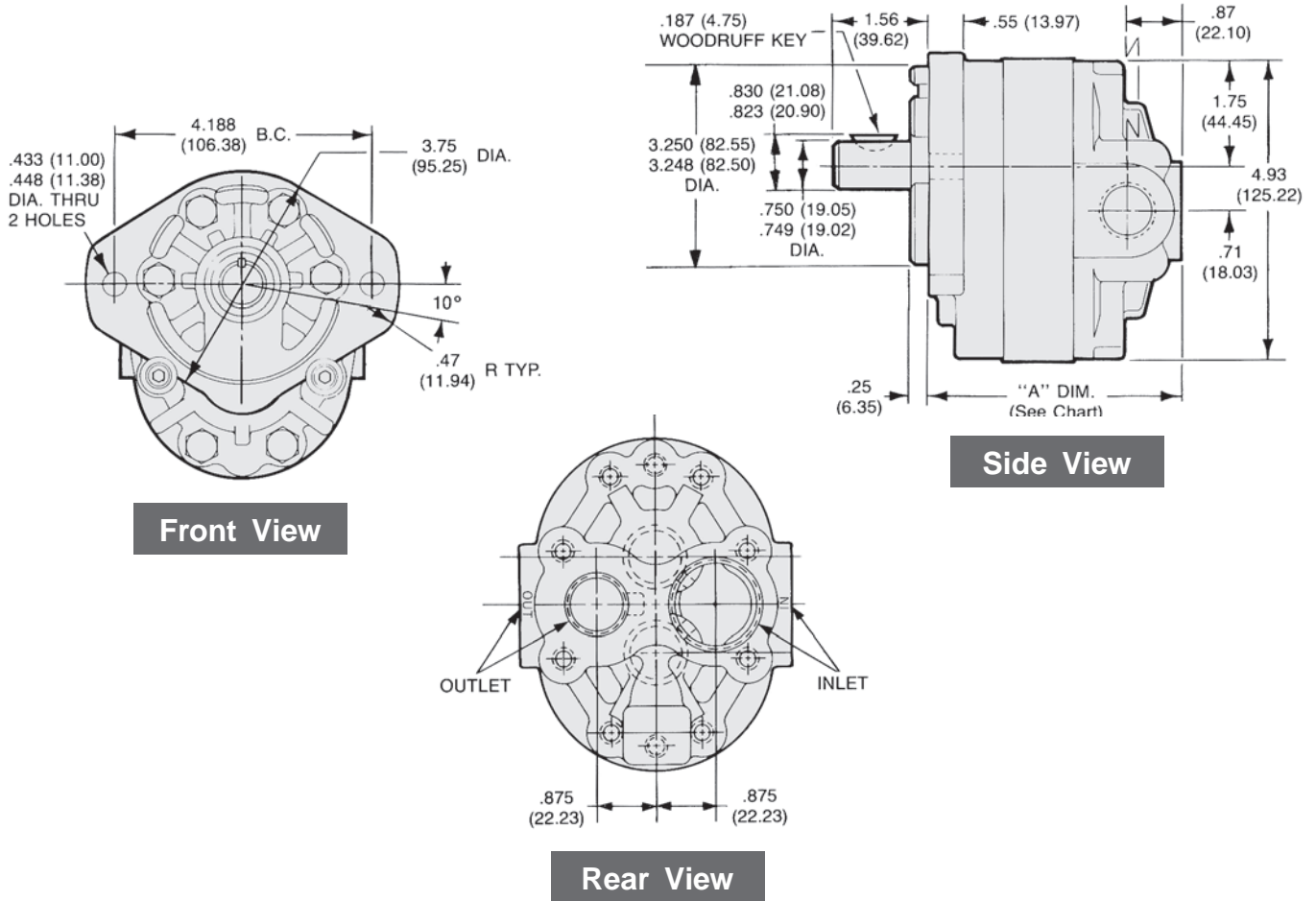

“A” Dimensions: Inches (mm)

Cover	H20	H25	H31	H39	H49	H62	H77	H90
A	3.34 (84.84)	3.43 (87.12)	3.54 (89.92)	3.68 (93.47)	3.86 (98.04)	4.08 (103.63)	4.63 (117.60)	4.92 (124.97)

Cover Option

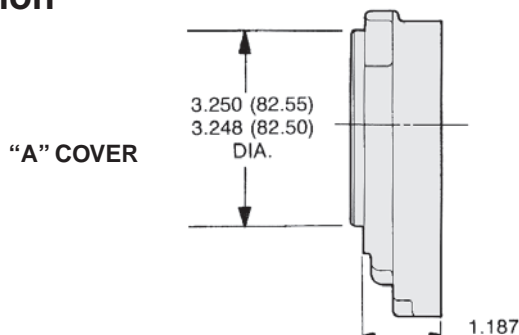

Dimensions – 2-Bolt Mounting

Series with built-in relief valve and flow divider

Dimensions: Inches (mm)

Clockwise rotation and “A” shaft shown
 (Port locations reverse for CCW rotation.)

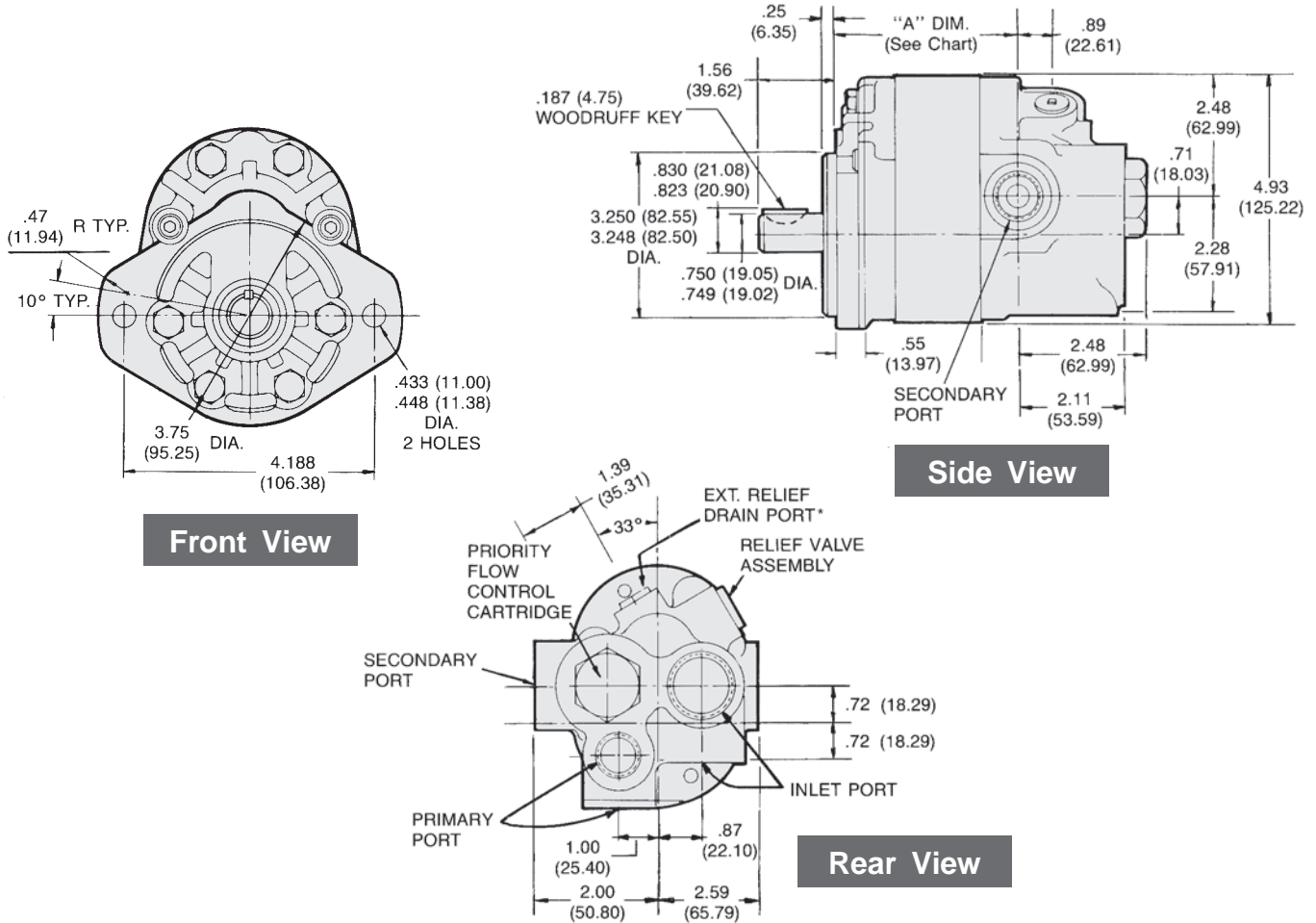

“A” Dimensions: Inches (mm)

Cover	H20	H25	H31	H39	H49	H62	H77	H90
A	2.43 (61.72)	2.52 (64.01)	2.64 (67.06)	2.77 (70.36)	2.95 (74.93)	3.18 (80.77)	3.45 (87.63)	3.75 (95.25)

Circuit Variations

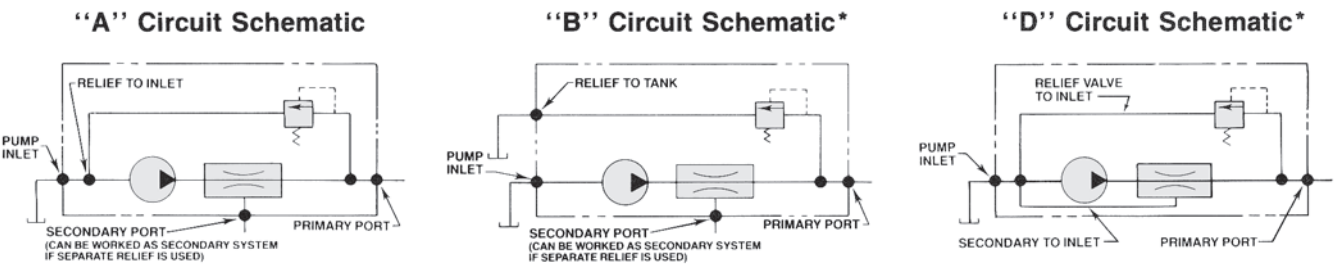

*NOTE: “D” Circuit: Relief valve flow and flow divider secondary flow return to pump inlet internally - primarily used in “on-road” equipment power steering. Relief drain port for “B” variation 9/16”-18 UNF-2B SAE Straight Thread.

Dimensions – Drive Shaft Configurations

Dimensions: Inches (mm)

“T” Shaft

- 3/4” Dia. 11 – tooth spline
- Flat root side fit
- Diametral pitch – 16/32
- Pressure angle – 30°
- No. of teeth – 11

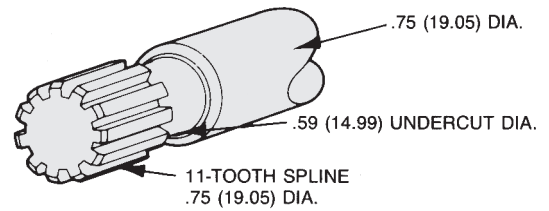
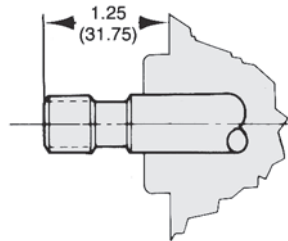

“B” Shaft

- 5/8” dia. 9-tooth spline
- Flat root side fit
- Diametral pitch – 16/32
- Pressure angle – 30°
- No. of teeth – 9

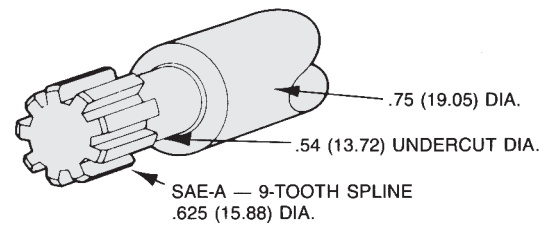
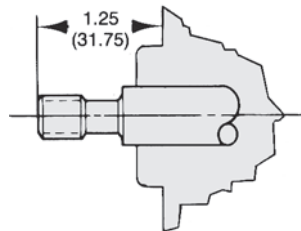

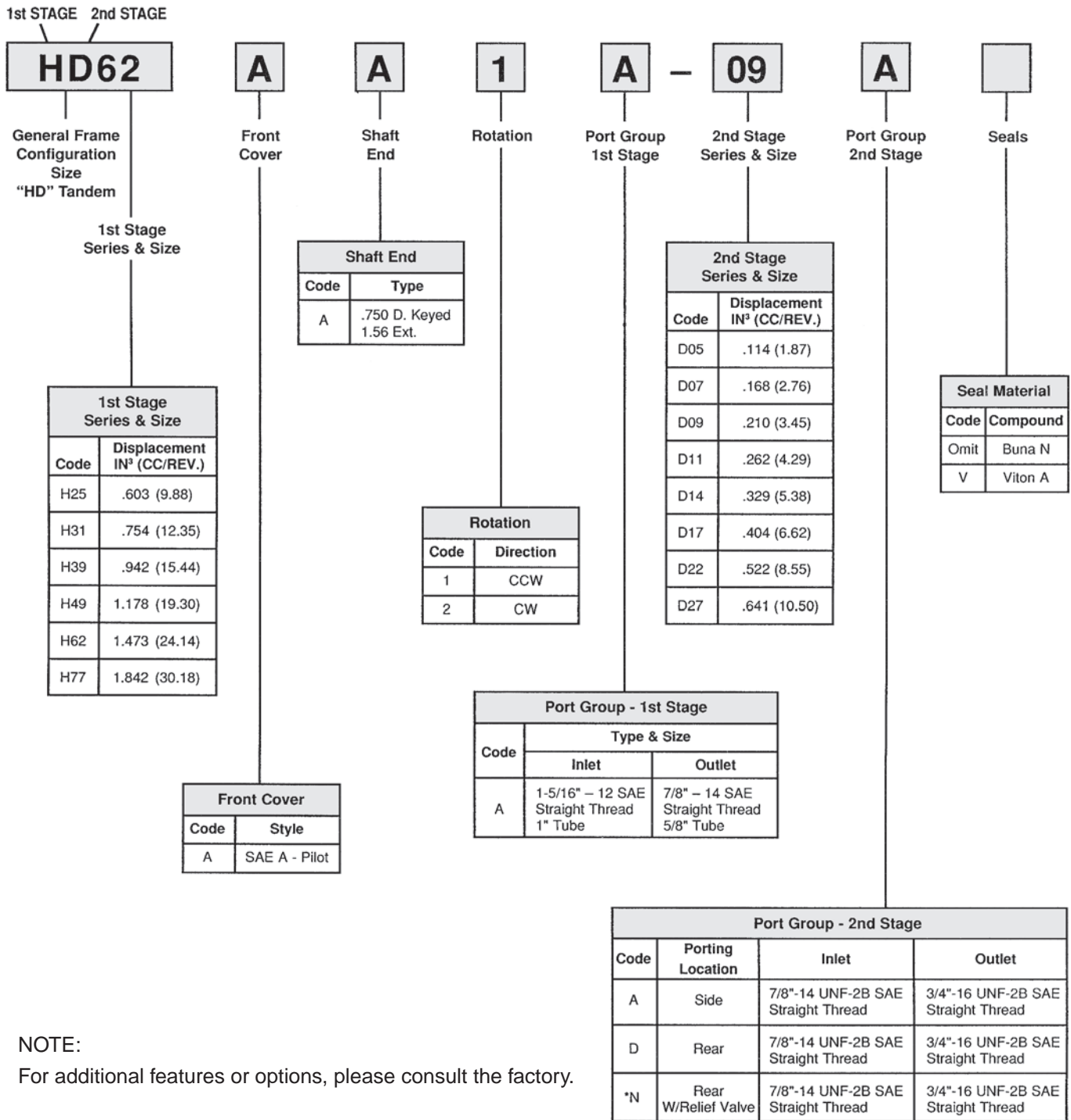

NOTE:
 For additional features or options, please consult the factory.

Buna-N Seal Kit: 805041K
 Buna-N Seal Kit with Plates: 815552K
 Viton Seal Kit with Plates: 825092K

* Relief valve limits rear pump pressure only.
 Specify pressure setting at end of model code.
 (PSI + 10, I.E. 1750 PSI = 175)

Performance Data

Series HD Fixed Displacement, Tandem Pump

Features

- Integral pressure-loaded pump design
- Individual inlet & outlet ports for 1st & 2nd stages of pump
- Fluids common/intermix between 1st & 2nd stages of pump.
- "H" series front cover mount - SAE "A" 2-Bolt
- Efficient at high-pressure operation
- Optional built-in relief - 2nd stage pump

Specifications

Flow Ratings:

See appropriate specification chart.

Pressure Ratings:

See appropriate specification chart.

Speed Ratings:

Minimum: 500 RPM

Maximum: Maximum rated speed of the larger displacement of the two pumps.

See appropriate specification chart for this data.

Torque:

- Combined: 800 in. lb. maximum total continuous duty
- 950 in. lb. maximum total intermittent duty
- 2nd Stage pump cannot exceed 260 in. lb.

For additional information, see the Performance Data chart on page 26.

Housing Material:

Die-cast aluminum

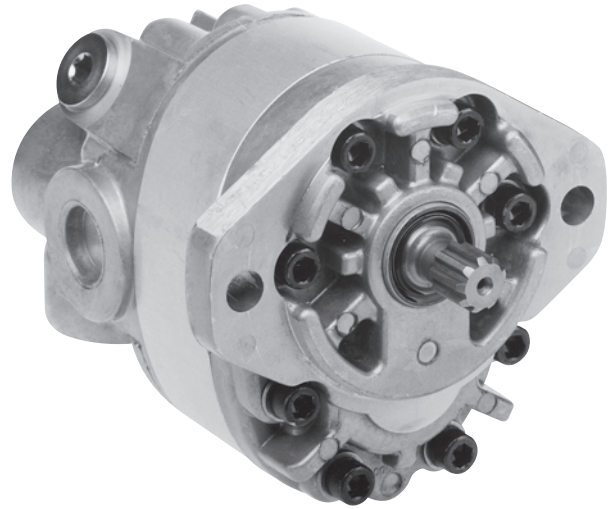

Schematic Symbol

(Basic Pump)

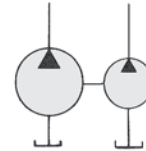

Installation Data

Inlet Conditions:

10 in. hg. max. vacuum condition (At 1200 RPM)

5 in. hg. max. vacuum condition (At 3000 RPM)

20 PSI (1.4 Bar) max. positive pressure

Operating Temperature Range:

-40°F to 185°F (-40°C to 85°C)

Filtration:

Maintain SAE Class 4

Installation Note:

See page 28 for specific recommendations pertaining to system cleanliness, fluids, start-up, inlet conditions, shaft alignment, and other important factors relative to the proper installation and use of these pumps.

Performance Data

	Model	In. Lb. Torque Per 1000 PSI	Maximum Allowable	
			PSI	RPM
FIRST STAGE	H25	121	2500	4000
	H31	152	2500	4000
	H39	190	2500	4000
	H49	237	2500	4000
	H62	296	2250	3600
	H77	372	2000	3600
SECOND STAGE	D05	23	2500	4000
	D07	34	2500	4000
	D09	42	2500	4000
	D11	53	2500	4000
	D14	66	2500	4000
	D17	81	2500	4000
	D22	105	2250	4000
	D27	129	2000	3000

Combined First and Second stage torque cannot exceed:

800 in. lb. Total continuous duty

950 in. lb. Total intermittent duty

Second stage torque cannot exceed 260 in. lb.

Example:

H39 @ 2500 PSI = 190 in. lb. x 2.5/1000 PSI = 475 in. lb. torque

D17 @ 2500 PSI = 81 in. lb. x 2.5/1000 PSI = 203 in. lb. torque

678 in. lb. total torque

Performance Data

Dimensions: Inches (mm)

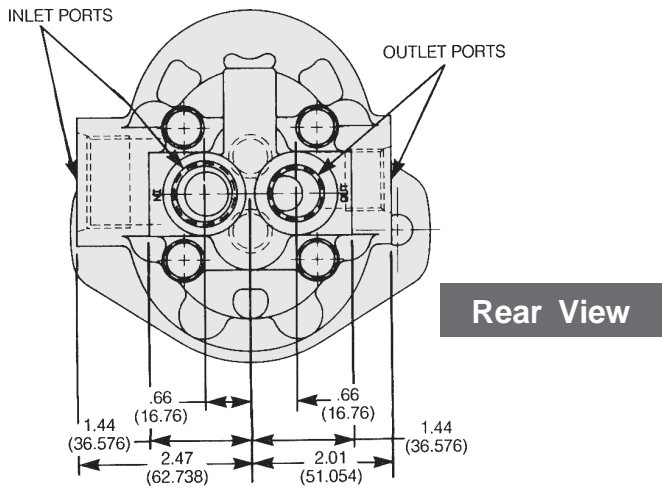
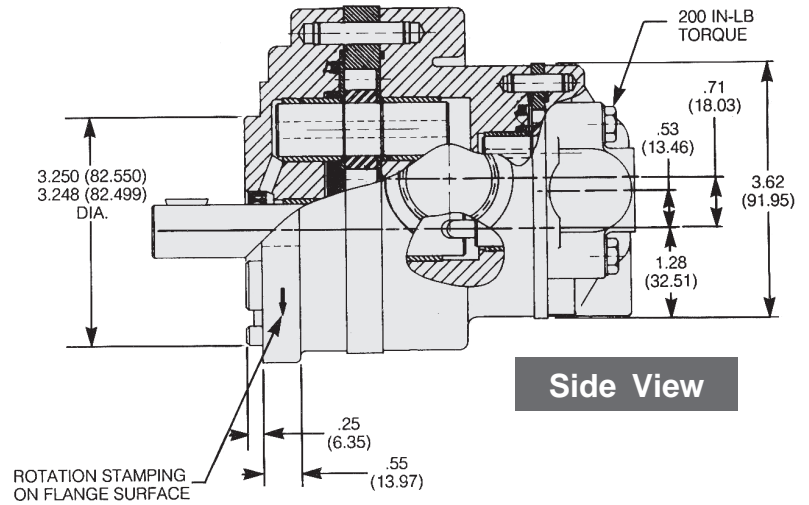
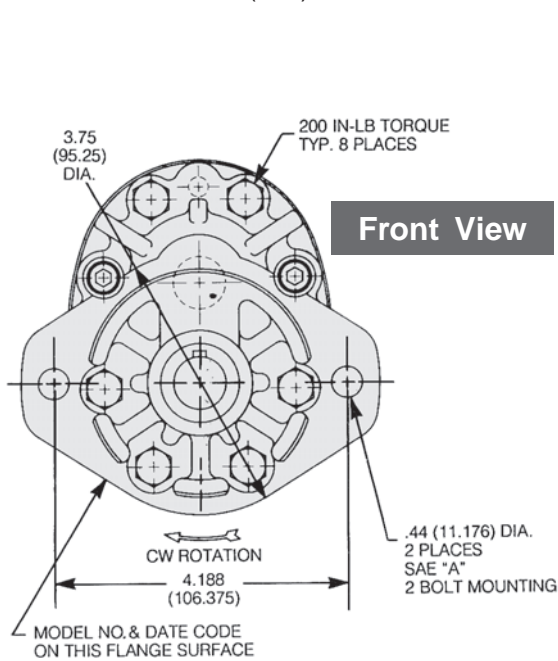

H-Pump Size	DIM "A"	D-Pump Size	DIM "B"
25	2.67 (67.818)	05	2.66 (67.564)
31	2.78 (70.612)	.07	2.77 (70.358)
39	2.92 (74.168)	09	2.81 (71.374)
49	3.10 (78.740)	11	2.89 (73.406)
62	3.32 (84.328)	14	3.01 (76.454)
77	3.60 (91.440)	17	3.13 (79.502)
		22	3.33 (84.582)
		27	3.52 (89.408)

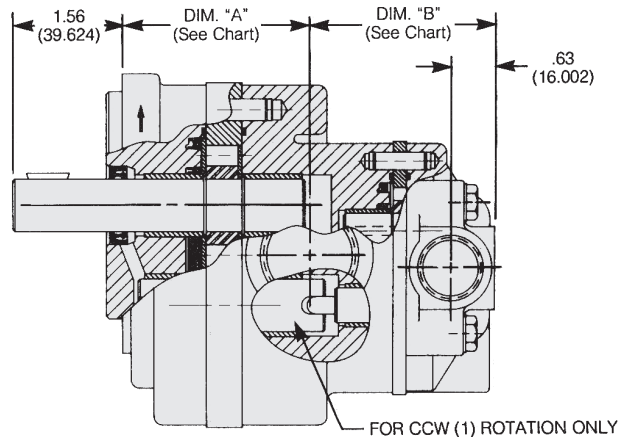
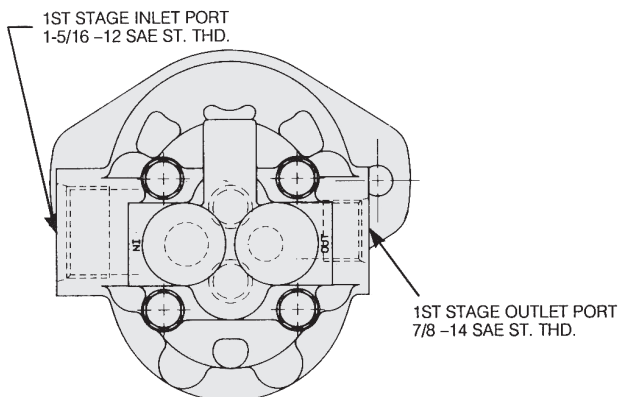

Rear (CCW) View

Side View

Fluid Recommendations**Fluid Recommendations**

Use premium-quality hydraulic fluid with operating viscosity range of 80-1000 SSU. The maximum start-up viscosity is 4000 SSU. The fluid should have maximum anti-wear properties, rust and oxidation treatment.

Filtration

For maximum pump and system component life, the system should be protected from contamination at a level not to exceed 125 particles greater than 10 microns per milliliter of fluid (SAE Class 4).

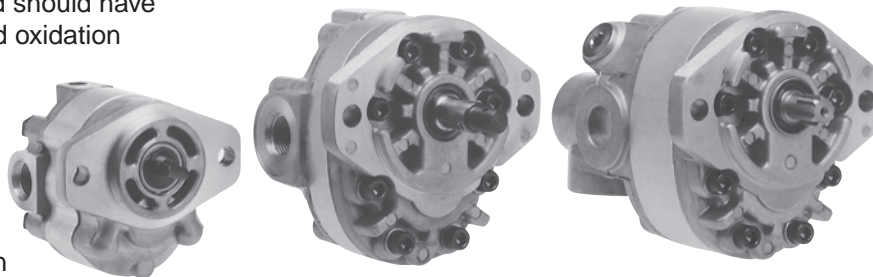
**Fluid Compatibility**

- Petroleum-based fluid
- Water glycols
- Water emulsions
- Transmission fluid
- Mineral oil fluid

NOTE: All data in this catalog are based on petroleum-based fluid. Pump pressure reduced by 1/2 of specified rating; pump speed rating, reduced by 1000 RPM from specified rating and "DU" bushings must be used when pump operates on water glycols and water emulsions. Consult the factory for special fluids.

Start-Up

On any start-up, where the pump suction line is empty of fluid, the circuit should be open to permit priming.

Inlet Conditions

Conditioning should not exceed 10 in. Hg. at 1800 RPM or 5 in. Hg. at pump maximum rated RPM. Inlet positive pressure should not exceed 20 PSI (1.4 Bar) maximum.

Shaft Rotation And Line Up

Pump and motor shaft alignment must be within .007 inches total indicator reading. Please follow the coupling manufacturer's recommended installation instructions to prevent end thrust on the pump shaft. Turn the pump by hand to assure freedom of rotation. The pump and motor must be on a rigid base.

The coupling should be sized to absorb the peak horsepower generated.

Installation And Mounting

The mounting position is not restricted.

Special Installations

Consult your Parker representative for any application requiring the following:

- Pressure above rated
- Drive speed above maximum
- Indirect drive
- Fluids other than those specified
- Fluid temperature above 185° F. (85° C.).

Instructions for Reversing Gear Pump Rotation

The basic tools needed are a vise, preferably with soft jaws, a torque wrench, a thin screwdriver, a small hone stone, a ratchet and a paper clip. The "D" series will require a 1-1/2" socket; the "H" series an additional 1/4" hex head driver. It is also recommended that you have extra heat shields and gaskets on hand. Part numbers are 655287 and 655288 for the "HD" series; 656942 and 656943 for "H" series.

To change rotation, hold the pump by the rear cover with the drive shaft pointing up. Remove all the bolts. The "HD" series will have four hex heads, and the "H" series will have six hex and two alien heads. For future reference, it would be helpful to scribe a line down the outlet side of the pump. If you choose not to mark it, the outlet port is usually the smallest.

If the pump has a key-type shaft, remove the key and hone down any burrs that may be on the shaft. This is important as the next step will be to lift off the front cover, and any sharp edges could possibly damage the front seal or bearing.

After the front cover is off, note the position of the little vent hole in the bronze wear plate, which should have come off with the front cover. The parts underneath also have a similar vent hole.

Remove in order, the wear plate, the heat shield, the gasket, and the V-seal. To facilitate this, make a small hook with a paper clip and lift the part high enough to slip a screwdriver under it and carefully pry up. Please note that the heat shield, in particular, is very brittle and may crack if bent.

After removing these four parts, reinstall the V-seal with the lips down in the front cover so that the vent hole is on the opposite side across from the reference mark. Use the screwdriver to seat it completely. Next, install the gasket, heat shield, and wear plate; again with the vent hole in line with that of the V-seal. The wear plate should be almost flush with the surface of the front cover.

Remove the center section and note the notch cut on the inside. This will be installed in line and next to the vent hole in the wear plate. The dowel pins used to locate the center section may be removed temporarily to facilitate sliding the center section over the gear assemblies. Be careful not to pinch the O-ring between the front cover and center section. If it doesn't want to stay in place, it can be "glued" using heavy grease.

If the pump is an "H" series, install the thrust plate

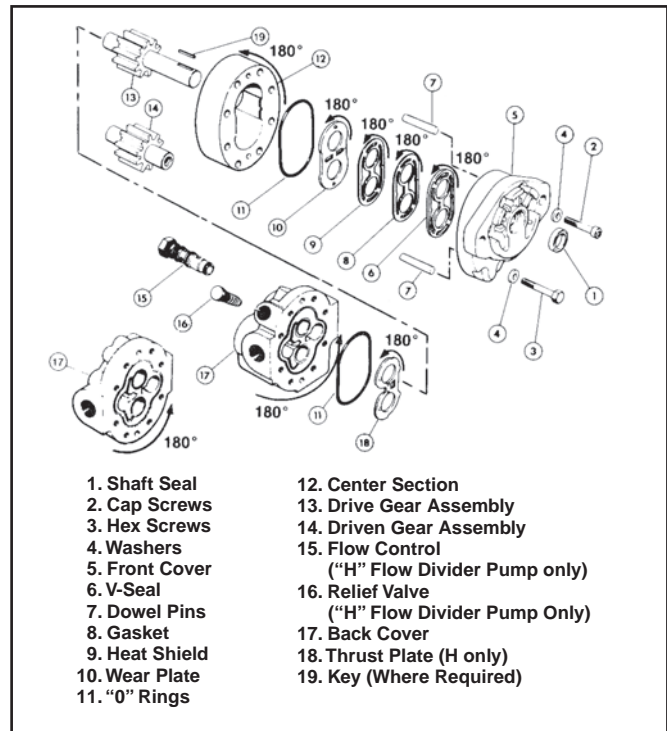

into the center section, orienting the side with the bar in line with the vent hole, ensuring that the bronze side faces the gears.

The rear cover is installed with the outlet side in line with the vent hole. The outlet side will be marked or can be identified by the smaller, internal cavity. As when installing the center section, be careful not to pinch the O-ring seal.

The line that was originally scribed on the side should now be located at 180° on both the rear cover and center section from that on the front cover.

Install the bolts and tighten down by hand. Then, torque to the proper setting, alternating from side to side. The correct torque specifications are 190-210" lbs. for the "D" and "H" series. Reverse or remove the rotation arrow originally stamped on the mounting flange.

Testing Procedure

After the pump has been reinstalled, run for 2-3 minutes before pressurizing. Try to apply pressure gradually for an additional five minutes, but do not pressurize for longer than 5 seconds at a time.