



OIL SOLUTIONS

PO Box 38  
Strathfieldsaye, VIC, 3551  
1800 OIL SOL  
1800 645 765  
[sales@oilsolutions.com.au](mailto:sales@oilsolutions.com.au)  
[www.oilsolutions.com.au](http://www.oilsolutions.com.au)  
"For All Your Hydraulic Needs"

 CONTINENTAL /  HYDRECO

# INDUSTRIAL AND MOBILE HYDRAULICS

Corporate Catalog



952-895-6400  
[continentalhydraulics.com](http://continentalhydraulics.com)

704-295-7575  
[hydreco.com](http://hydreco.com)

# INDUSTRIAL AND MOBILE HYDRAULICS

## Welcome to Continental and Hydreco

As the world of Fluid Power evolves, so do we, at an increasingly faster pace. From hydraulics to motion and mobile solutions, from the mid-west to the world, from analog control logics to computerized electronics, we are riding the wave of technology in our fast changing markets.

Continental, an established part of the Duplomatic Motions Solutions Group, has been at the forefront of power transmission innovation for over 60 years and again is a leading force in transforming the industrial world we live in.

Facing global consolidation of manufacturers of fluid power and automation into a few "gigantic" and often irresponsible multinationals, most customers have been left-essentially-with two choices. Either put themselves entirely into the hands of these larger suppliers, or finally rediscover the lively world of small-to-medium size companies like Continental Hydraulics out there.

This is the new opportunity for global growth, the future of Industrial and Mobile Motion Solutions and Power Transmission.

Let's work together.

### 4 Pillars of Difference



Our Four Pillars guide us in our day-to-day business to ensure we are delivering value to our customers



1800-OILSOL  
1800-645765

<https://oilsolutions.com.au/>

[sales@oilsolutions.com.au](mailto:sales@oilsolutions.com.au)

## MOBILE PRODUCTS

### GEAR PUMPS

- HY Series
- World Series
- Roller Bearing Series
- QX5 Series
- QR Series

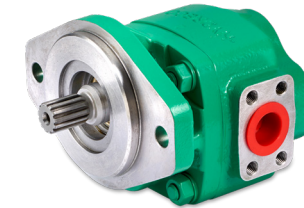

### VALVES

- NFPA - CETOP
- Directional / Proportional
- Monoblock
- Sectional



### PILOT CONTROL VALVES

- Joysticks
- Knobs, Levers and Handles
- Petals
- Pilot Supply Unit



### ELECTRAULICS MECHATRONICS

- CAN/Bus Control Systems
- Master Control Units
- Display Units
- HY ECU



### CAB CONTROLS

- Switch Control
- Tipper Controls
- Air Controls
- Rocker Switches

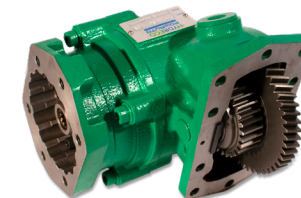

### POWER TAKE OFF'S

- Hydraulic Solutions

### CYLINDERS

- Telescopic

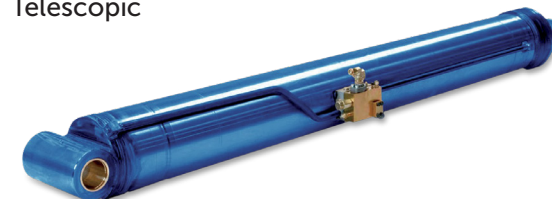

## INDUSTRIAL PRODUCTS

### VARIABLE VANE PUMPS

- Hydraulically Compensated
- Direct-Spring Compensated

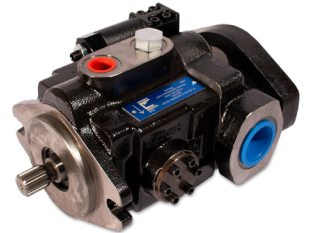

### PISTON PUMPS

- Trunnion Design
- Saddle Block

### DIRECTIONAL CONTROL VALVES

- Solenoid – Direct Operated
- Solenoid – Pilot Operated
- Spool Position Monitored and Kits
- Explosion Proof Hazardous Location
- Pneumatic – Hydraulic – Manually Operated



### PROPORTIONAL VALVES

- High Performance Servo-Proportional
- Directional Control without On-Board Control
- Directional Control with On-Board Control
- Directional Control with Feedback
- Hazardous Location Valves
- Compensated Flow Control
- Pressure Control (Relief/Reducing)

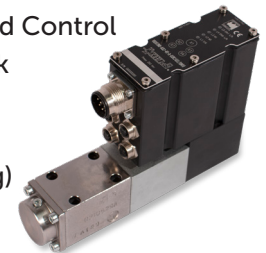

### MODULAR STACK VALVES

- Check Valves
- Pressure Control Valves
- Flow Control Valves
- Blocking Valves
- Load Holding



### SUB-PLATE AND IN-LINE VALVES

- Threaded In-line Body
- Sub-plate Mounted

### CUSTOM and STANDARD POWER UNITS

- JIC Style
- Low Profile
- L – Shaped
- Little Champ®





# HYDRECO

# MOBILE HYDRAULICS

## Engineered to Move

Superior performance, outstanding quality, excellent service and expert advice. Those are the cornerstones of the global hydraulics capability represented by Hydreco.

Our hydraulic gear pumps and motors, main control valves, pilot control valves and power take-offs provide the power and control behind the biggest names for equipment in construction, forestry, marine, agriculture, industrial and mining. Practical performance, allied to knowledge of the user's application, and backed by superb technical skills and capabilities, ensures we have the strength to satisfy hydraulic demand on a global level.

## The family is growing

Continental Hydraulics and Hydreco are the driving force for industrial and mobile applications across North America. Our combined and dynamic offering provides our partners with the confidence to specify to the highest standards.

A natural evolution in the growth of Continental has been to develop proven mobile application technology and to partner with a global player - resulting in a new and exciting proposition. Both part of the Duplomatic Motion Solutions Group, are supported by investment into technology innovation and expertise that our customers value.

A global corporation with companies and plants throughout the UK, Australia, Italy, India, etc. and now co-located at Continentals main North American site in Minnesota. Manufacturing and selling a full line of mobile hydraulics starting with their complete offer of gear pumps, of David Brown Hydraulics heritage (inventor of the first gear pumps).

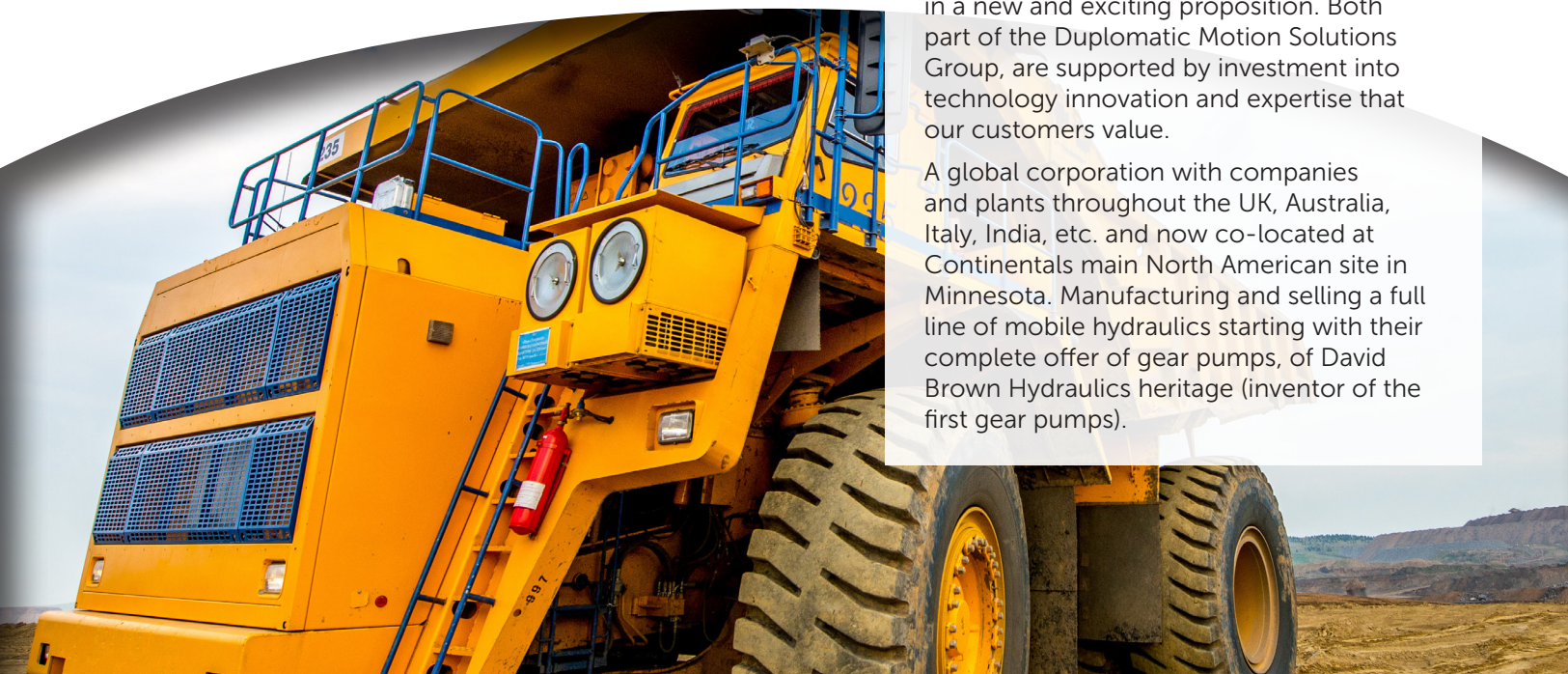

## HYDRECO

# GEAR PUMPS

Performance, long life reliability, robustness and ease of use even in the harshest of environments



HY2 SAE A  
Aluminium Tandem

The Hydreco Hydraulics pump range includes helical gear and spur gear pumps together with cast iron and aluminium bodies. High durability, long life, and high efficiency are features of these pumps, which, when combined with the low noise characteristics of the helical gear pumps, make them highly suitable for modern machinery.

Depending on model, features include: spur gears, helical gears, displacements from 1.4 to 240cc/rev, uni-directional or reversible motors, single or multiple assemblies, cast iron or aluminium bodies, high pressure ratings.

Gear Pumps	HY Series	World Series	Roller Bearing Series	QX5 Series	QR Series
Applications	1.4 to 98 cc/rev (0.73 to 14.6 cu in/rev)	12 to 240 cc/rev (0.73 to 14.6 cu in/rev)	12 to 237 cc/rev (0.738 to 14.43 cu in/rev)	23 to 68 cc/rev (1.40 to 4.15 cu in/rev)	16 to 220 cc/rev (0.98 to 13.42 cu in/rev)
Rated Pressure	250 bar (3625 psi)	350 bar (5075 psi)	207 bar (3000 psi)	250 bar (3625 psi)	250 bar (3625 psi)
Input Speed	450 to 5000 RPM	450 to 3500 RPM	400 to 3000 RPM	400 to 3000 RPM	450 to 3000 RPM
Bodies	Aluminum (5 frame sizes)	Cast Iron	Cast Iron	Cast Iron	Cast Iron

### Key Features:

- High volumetric efficiency
- Very low noise levels
- Long life plain bearings
- Multiple pumps on one shaft
- Popular drives/ports
- Range of custom interfaces
- Compatible with environmentally aware fluids
- Flexible build configuration



### Applications:

- Mining Equipment
- Excavating / Backhoe
- Wheel Loader
- Marine
- Crank

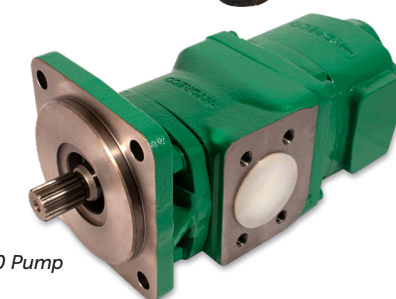

WSP40 Pump

### HY Series

Available in 3 mount frame sizes with an aluminum alloy housing, two gear wheels supported by sleeve bearings and cast-iron flange and cover. The pumps / motors can be supplied as single or multiple units with a huge variety of options on flanges, shafts and ports, providing the right setup on each application.



### World Series

Single and multiple pump options covering all applications. Low noise spur gear technology minimizes pressure ripple and noise.

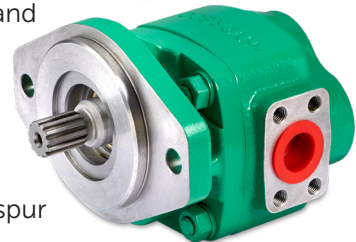

### Roller Bearing Series

The pump contains pressure-balanced wear plates, utilize a very rigid two-piece construction and specially designed, long life continuously pressure lubricated roller bearings. The series maintains its bi-rotational pump or motor capabilities.



### QX5 Series

QX5 pumps incorporate unique patented helical gear technology to give the highest performance with lowest noise levels. Pumps can be supplied as single, double, triple or quadruple units.

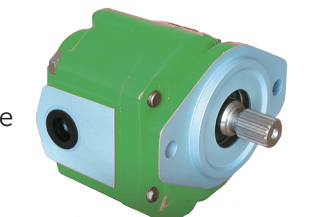

### QR Series

QR spur gear pumps are designed for minimum pressure ripple. Pumps can be supplied as single, double, triple or quadruple units.



# VALVES: NFPA - CETOP DIRECTIONAL / PROPORTIONAL

## Subhead Rugged and Durable

Hydraulics range of electrical valves includes some for specific applications while others can be used for a wide variety of applications. Control options include proportional directional, direct operated, solenoid directional, pressure compensated and sectional directional with load sensing for example.

Depending on model, operating pressures are up to 350 bar and flow ratings up to 120 litres/min.

### HDS3

Solenoid directional valves, direct operated. Operating pressure up to 350 bar and flow capacity up to 80 l/min.



### HDL5

Solenoid directional valves, direct operated. Operating pressure up to 320 bar and flow capacity up to 120 l/min.

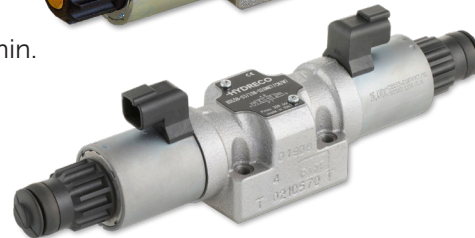

## Special Application

### DD

Flow diverters with 6 ports, 2 positions. They allow the connection of the pressure lines with two working lines. The solenoid switches the flow alternatively through the flow paths. Version with drain port allows higher pressures.

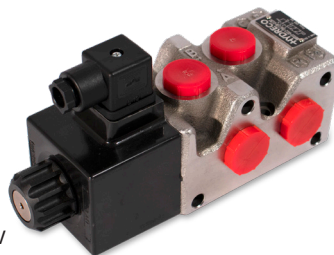

### HDR

Self-reversing valve - Directional control valves hydraulic actuated, with self-reversing spool. Operating pressure up to 350 bar 50l/min (HDR3), 320bar 60 l/min (HDR5).



## MONOBLOCK

### Subhead Rugged and durable

We offer a wide range of aluminium and cast iron main control valves.

### V37, V38, VT and MVT150 Series

Available in 1,2 and 3 spool mono-block form. High grade cast-iron housings provide strength for minimum deflection under load and free spool movement. Potential leak points are minimised. Spools and centring springs are designed for remote hydraulic pilot operation by the David Brown HPV\* pilot controller range. Hollow spool construction with built-in load hold checks for precise safe metering.



### 033 Sectional Control

This product is rated at 150 litre/min and can sensibly be used down to 60 litre/min. 033 sectional valves are versatile, being sectional in construction and can be built in assemblies ranging from one to ten sections, with a wide variety of spool options and controls ranging from manual to pilot hydraulic to electro-hydraulic.

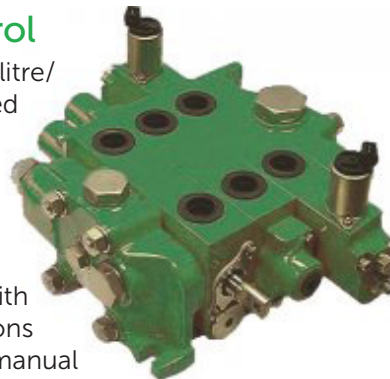

#### Key Features:

- 30 to 450 l/min (7.9 to 119 gal/min) and up to 250 bar (3500 psi) system pressure
- Parallel, tandem and mixed circuits available depending on model
- Mono-block and sectional high grade iron housings
- Wide range of spool types and metering characteristics
- Operating systems: manual, hydraulic, electro-hydraulic and pneumatic
- Integral system relief valve together with individual port relief and make up options available

## SECTIONAL

### Subhead Rugged and durable

The Hydreco Hydraulics range of valves includes some for specific applications while others can be used for a wide variety of applications. A range of control options is available, from manual, to pilot hydraulic, to pneumatic control, to electro hydraulic control.

Depending on model, features include: Sectional or monoblock construction, flow rating to 450 litres/min, multiple spool options, manual / hydraulic / electro-hydraulic / pneumatic control options, tandem circuit, multiple inlets..

### SDL, SDM and SDS

Sectional directional control valves and can be assembled in parallel with up to 10 working sections. The same components allow creating series circuits by inserting plugs in order to modify the oil path. Operating pressure up to 320 bar and flow capacity up to 60 l/min.



### SDN

Sectional directional control valves and can be assembled in parallel with up to 8 working sections suitable for compact applications, mainly in mobile industries and in mini-power packs. Operating pressure up to 350 bar and flow capacity up to 15 l/min

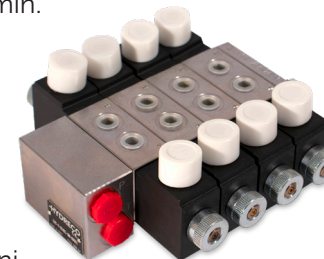

### SLSE

Sectional directional control valve with load sensing feature. It can be assembled with up to 8 working sections (proportional and solenoid valves together). Each module is equipped with a meter-in compensator that keep the flow constant, independently from load changes. Sections with pressure compensator are not influenced by other operated functions, provided that sufficient pump capacity is available. Operating pressure up to 315 bar and flow capacity up to 45 l/min.



#### Key Features:

- Sectional Construction allows build-up of 1 to 10 spool valve banks.
- Spool sections for Parallel and Tandem circuits (or Combination circuits).
- Inlet sections for Single pump systems with optional Pilot-Operated System-Relief valve.
- Mid-Inlet Sections for 2-pump Systems (flows separated or combined as required with optional second-system relief valve).
- Valves are normally supplied fully assembled and tested to Customer requirements but individual sections can also be supplied where additional (optional) spools may be required.
- A wide range of spool types.
- Optional Service-Port Relief and anti-Cavitation Valves.
- Manual, Hydraulic-Pilot, Pneumatic-Pilot and Electric Remote operation.
- Wide range of Spool-Positioning devices including Mechanical and Electrically-Operated Detents.
- Minimum Neutral 'Creep' of Cylinder.

## HY Series Valves

The HY Range of product covers Directional Control Valves in both monoblock and sectional construction. The range has been developed over a number of years and is ideally suited to a wide range of industries, including construction and earth moving, materials handling, agriculture, and many more.

Some of the valves in the range are designed with specific applications in mind. Many of the valves are ideally suited to be matched with our extensive range of remote hydraulic pilot control valves in order to provide the ideal control.



# HYDRECO

## PILOT CONTROL VALVES

Remote control valves for pilot circuits, hand and foot operated

Remote pilot operation of directional control valves with low effort controls.

- Single, multiple and joystick controllers
- Stylish, ergonomic designs for modern cabs
- Range of accurate, low hysteresis control curves
- Dedicated pilot valves, with magnetic detentes, to control 2 or 3 spool directional valve for wheeled loader applications
- Range of valves with foot pedal operation



### HPVM

A very precise remote control valve with individual lever control with the advantage of being able to bank the units together. Compact and light weight. Suitable for arm rest of console mounting. Compatible with a wide range of product. Stylish good looks suitable for modern cabs. Operator is insulated from high temperature components. Proven, simple pressure reducing elements. Wide range of low hysteresis, high accuracy, pressure control curves. Wide range of electrical options in both standard and multi-functional ergonomic handles.



### CPVL106

Joystick with the inclusion of electrical and mechanical detent is designed specifically for wheeled loader applications.

Supported by an extensive range of control curve characteristics and handles options and can be supplied to control either two or three service loader applications.



### HPV1

HPV pilot control valves with their single lever dual axis control, and supported by an extensive range of control curve characteristics and handle options, suitable for a wide range of both mobile and industrial applications.



### HPV2

A very precise, dual axis remote control, for the progressive operation of two services either individually or in combination with each other.



### HPVL / SPVL

A precise remote control for the progressive operation of a main control valve, either with individual levers (SPVL), or with a dual axis joystick for individual or simultaneous control of two services (HPVL). Magnetic detentes are fitted, making the valve suitable for wheeled loader applications. Single and dual axis R.C.V. for loaders.



### MDC - Electrical

Latest technologies based on SMD Hall effect sensors and micro controller's architecture. New design meant to provide a comfortable and fine control of mobile and industrial applications. It's a single lever with single / dual axis control, supported by an extensive range of handle options.



### HPVB / HPVE

New monoblock pilot valves with 1(HPVE) or 2(HPVB) control levers that replaces PRSVE and PRSVB.

### Knobs, Levers and Handles

Available for fitting either to Hydreco pilot valves or other types of devices. The handles can also be used as stand alone device in many applications.

The selected materials suit both indoor or outdoor environments and are reliable, strong and suitable for heavy duty applications.

Wide range of knobs and straight lever are available with different options, integrating switches and push buttons. Ergonomical MFE, EXM, and MFE2 handles offer multifunction and bespoke solutions for the most demanding applications; they can be equipped with a wide range of controls: rocker switch, proportional roller, mini joystick, latched or momentary push buttons, toggle switch, four way switch etc.



The ergonomic handles are available for both left and right operation selecting the proper tilting option. MFE2 Handle is ready for standalone applications, integrating a specific electronic board. Different circuit arrangements can be accommodated within the handle and the wiring can be designed as per customer's specifications.



Many more options available.

### Petals HPVP Series

The range of foot pedal controls supported by a huge variety of characteristics, makes it suitable for a wide range of applications.

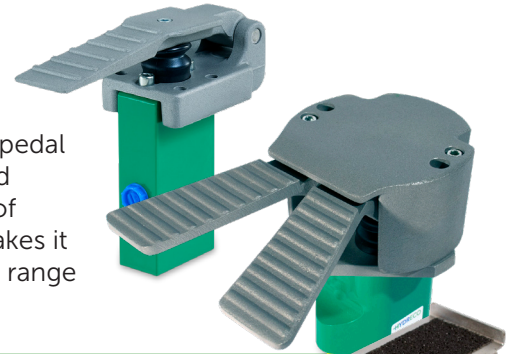

#### Key Features:

- Compact and lightweight
- Simple to mount
- Ports ideally positioned for easy installation
- Wide range of compatibility
- Operator is protected from high temperature components
- Low hysteresis, high accuracy, pressure control curves
- Range of operator pedal efforts available
- Rubber boot protection prevents contamination and operate in the toughest environmental conditions
- Plunger manufactured from non-corrosive steel
- End of stroke limited externally to prevent any damage to internal components
- Optimized angular movement of foot pedal

### Pilot Supply Unit - SUH Series

Direct acting pressure reducing valve which can be connected to either one or two main circuits via ports P1 and P2. Both ports feed through a shuttle valve to prevent circuit interaction. Reduced pressure is supplied to port U1 and U2.



A pre-set relief valve is fitted to prevent over pressure, and the unit is supplied with an accumulator connection for emergency power supply. A solenoid attachment is available to act as a safety system and to maintain the accumulator charged for a longer period by preventing leakage downstream to the 'U' ports. An integral filter is available to protect the output line and hence downstream components. Optional 2 way and 3 way, 12 or 24 VDC solenoid valves for safety and extended accumulator storage time.



# HYDRECO

## ELECTRAULICS MECHATRONICS

### CAN-bus control systems

Products and software to build hydraulic and digital control systems for mobile machinery.

#### Master Control Unit ▶

Master unit with CAN-bus/CAN open communication used as the central control unit. Contains the machine's application program controls and monitors all the units included in the system. 4 double-acting closed loop regulated PWM outputs and a total of 23 I/O's for analog and digital signals are included. I/O's can be user defined as either input or output. CAN-bus/CAN open is used as the main communication protocol but the unit is also provided with a separate CAN-bus SAE J1939 port that can be used for integrated control and monitoring of external systems such as electronically controlled diesel engines and power shift gearboxes.



- Key Features:**
- Digital and Analogue inputs and outputs
  - Inbuilt safety functions
  - Master / Slave system ability
  - Easy to use programming software
  - GPS and other remote communication enabled



#### Electraulics Display Unit

Terminal with CAN-bus/CANopen communication for monitoring and control. The TFT graphical display and software allows user defined menus and symbols to meet individual system requirements and customer needs. Unit contains 3 digital inputs that can be user defined and is provided with a separate CAN-bus SAE J1939 port that can be used for integrated control and monitoring of external systems such as electronically controlled diesel engines and power-shift gearboxes.



#### HY ECU

The CAN Bus system combines years of experience in the hydraulics market with the most advanced electronic control devices for mobile applications. The HY ECU's range, compliant with both SAE J1939 and CANopen protocols, represents the solution for vehicle and functions control.



## CAB CONTROLS

Designed for modern truck cabs, these controls are manufactured to exacting tolerances ensuring consistent, trouble-free operation. Including: Switch control, tipper control, air control and rocker switches.

#### CK98

Designed for modern truck cabs, with a compact design, these controls are manufactured to exacting tolerances ensuring consistent, trouble-free operation. Configured for discreet fitments – ordering the right control for your truck cab is easy.



#### CK167

Electric PTO/Valve Control - Designed to allow a universal installation of a truck and trailer tipping system in a confined space, the new TCU, CK167 leads the way with programmability and functionality. With only a pendant control located in the cab, the tipping operations can be controlled from any convenient location.



# HYDRECO

## POWER TAKE OFF'S

### PTO's and truck hydraulics solutions

PTO's and on-road hydraulics with a reputation for rugged design and long life. Serving the transport hydraulic market in applications such as tipping/dumping, waste management, municipal, cranes, recovery vehicles, mining, drilling and construction.

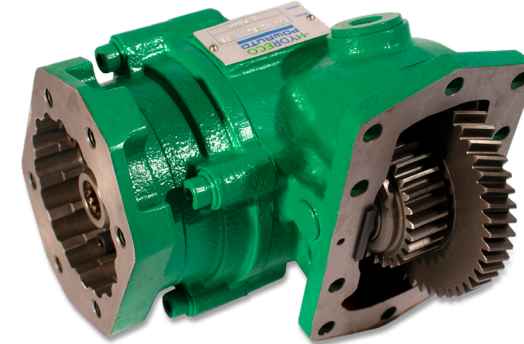

- Key Features:**
- With a comprehensive range of PTO's for most vehicle transmissions, the Hydreco Powauto solutions will be your partner for any application.
  - PTO's with constant drive, sliding gear and hot shift options catering for all applications across extensive range of US, European and Japanese vehicles.

#### Transmission Applications:

Aisin, Allison, Eaton Fuller, Eaton, Fuso, Hino, Isuzu, Iveco, Mack, Mercedes Benz, Mitsubishi, Power Take, Scania, UD and Volvo/ZF

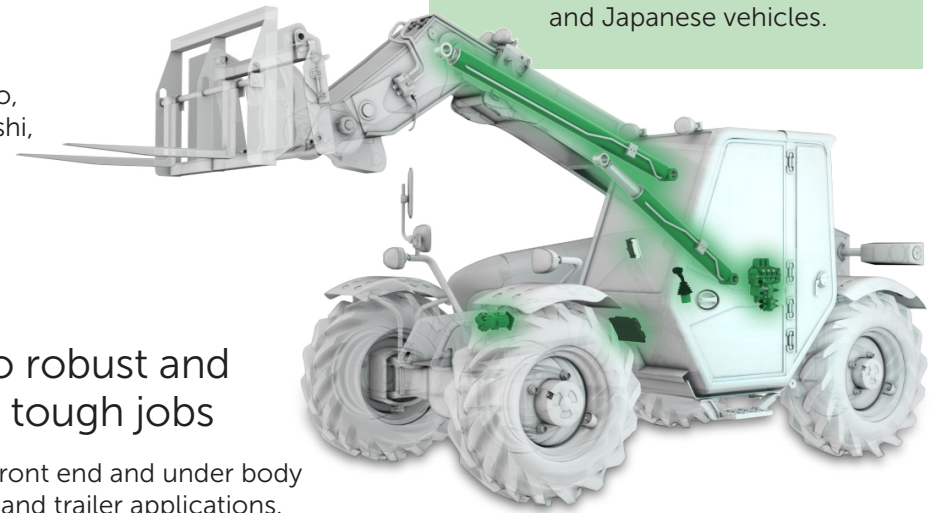

## CYLINDERS

### Telescopic cylinders built to robust and rugged standards to do the tough jobs

Robust and reliable traditionally designed front end and under body telescopic cylinders for tipper/dump truck and trailer applications. It comes with various combinations of stroke and closed height with 3, 4 or 5 moving stage units. Outer cover and spherical bearing versions available with load capacity 15-40 tons.

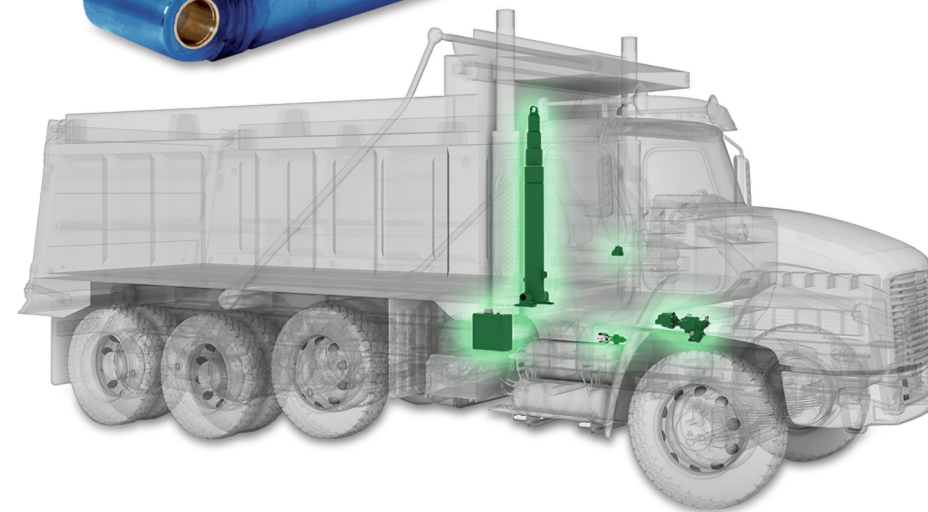
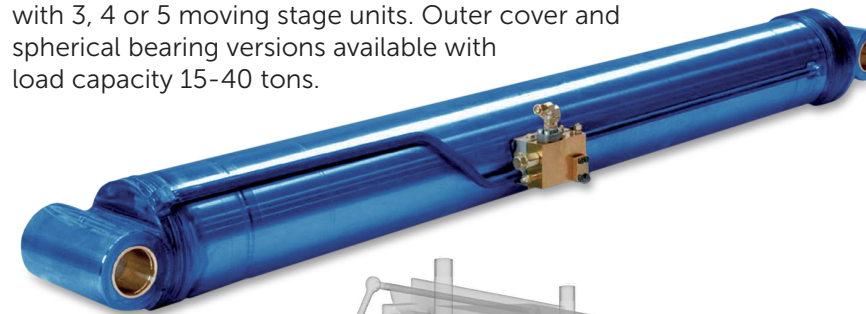

- Key Features:**
- All welded internal parts
  - Rugged nylon guide rings with maximized overlap
  - Breather on all sizes
  - Easy to adjust traditional Vee-pack seals
  - Gland nut design throughout
  - Both joints with grease nipple as standard
  - Strong long lasting weld arrangements of cylinder fittings
  - Customization on stroke and closed height for application adaptation
  - Large oil inlet porting for safe hose connections
  - All stages chromed



1800-OILSOL  
1800-645765

<https://oilsolutions.com.au/>

[sales@oilsolutions.com.au](mailto:sales@oilsolutions.com.au)



# INDUSTRIAL HYDRAULICS

## Valves, Pumps and Hydraulic Power Units

Provides durable, high performance engineering solutions and delivers exceptional quality to you through our robust products and experienced people.

Manufactures a wide range of directional valves, pressure controls, modular stack valves, servo-proportional valves, proportional pressure control valves, hazardous location / explosion proof valves, position monitored valves, variable vane pumps, variable piston pumps and hydraulic power units with flow rates up to 500 GPM, tank size up to 1000 gallon, and pressure up to 5000 PSI.

## Quality

Quality Management System, which complies with the ISO 9001:2015 Standard, (Certification February 27, 2019 to April 3, 2022) is aimed at:



ISO 9001:2015  
CERTIFIED

- Promoting a vision of quality in each function of our organization and challenging the whole team to always strive for standards above those of our competitors;
- Maintaining a talented and productive work force that determines our reputation and vitality;
- Ensuring that innovation and improvement are at the forefront of our business by constantly challenging ourselves to exceed our customers' expectations;
- Monitoring our customers' satisfaction level through the analysis of claims and by performing thorough evaluations of products not meeting customer requirements.



## PUMPS

### Vane and Piston Pumps

Continental has been manufacturing variable volume, pressure compensated pumps since 1955! Our years of knowledge has resulted in some of the most robust, long life pumps available today.

Vane Pumps with inherent wear compensation and use of Hydrodynamic Bearing are known for their ability to out perform many other design pumps.

Piston Pumps with enhanced Trunnion bearing design are ideal for high cyclic applications.

Product knowledge and application know-how is our strength, that our customer have come to rely and depend on!

#### Key Features:

- Continuous duty medium pressures pumps, up to 4000 PSI (275 Bar)
- Fast response and recovery times
- High volumetric and overall efficiency
- Very low noise level
- Tandem mounting capable
- Pressure compensated, load sense, remote pressure, dual pressure, torque limiting options
- Interchangeable with many pump manufactures



#### Applications:

Lumber and Forestry - Edger, Saw Head Position, Presses  
Food and Beverage - Conveyors, Packaging, Dump Systems  
Power Generation - Crushers, Positioning/Tracking, Gates  
Heavy Equipment - Presses, Lifts, Forming Press, Stacker's  
Metal Forming - Presses, Welders, Clamp, Conveyors



Pumps	Vane - PVX Series	Vane - PVR Series	Piston - HPVR Series	Piston - LPV Series
Displacement from	1 to 10 cu.in. (16.8 to 164 cc)	0.7 to 9.9 cu.in. (11.5 to 162 cc)	.88 to 3.97 cu.in. (14.4 to 65 cc)	.48 to 2.8 cu.in. (8 to 46 cc)
Continuous duty pressures to	3000 PSI (210 Bar)	2000 PSI (138 Bar)	4000 PSI (276 Bar)	3000 PSI (210 Bar)

### Vane - PVX

Hydraulic control via bias pistons acting on the cam ring making them very application flexible by allowing for a variety of control options. The large pumping chambers using superior port plate design allows for smooth output flow and pressure while providing the ability to work with poor fluid conditions.



### Vane - PVR

Directly control via a spring acting on the cam ring making them extremely reliable and durable pump choices available. With the fewest moving parts, the direct spring forces volume change based on system demand with fast reaction time and walking ring technology. Field proven pumps for a low cost.



### Piston - HPVR

Hydraulic control via a variety control compensator, making them very application flexible by allowing for a variety of control options. The trunnion bearing style swash plate design allows for reduced hysteresis and long life in high cyclic applications.

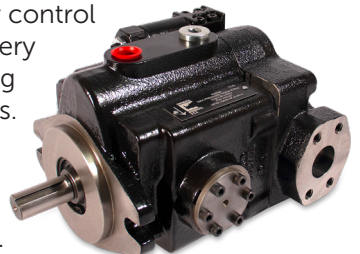

### Piston - LPV

Variable displacement axial piston pumps with variable swash block, suitable for applications with open loop circuits and intermediate pressures requiring low noise levels and small frame sizes.



# VALVES: DIRECTIONAL CONTROL

Rugged, durable and efficient

High flows and low pressure drops make them the perfect choice for new systems or to improve older ones. Continental manufactures NFPA D03 to D10 size manifold mounted directional control valves. With pressures to 5000 PSI continues duty and many function flow direction options, we have the correct valves for your application.

**Applications:**

- Industrial Machinery
- Oil and Gas/Mining
- Food and Beverage
- Lumber and Forestry
- Power Generation
- Safety

**Key Features:**

- AC and DC voltages and connection options
- Pressures to 5000 PSI
- Interchangeable with all major manufactures
- Solenoid / Soft-Shift / Hydraulic / Pneumatic / Manual Lever / Position Sensors



**IO-Link Easy integration**

Enable diagnostics and setting adjustments, as required by Industry 4.0. Advantages ranging from predictive maintenance to performance measurements for productivity.

As production demands increase, factories are turning to real-time data to make smarter decisions. What if your devices could tell you what they are doing, how well they are doing and instantly alert you to problems?

IO-Link solutions enable the integration of hydraulics valves, both ON-OFF and Proportional, in digital communication systems. IO-Link is not a communication bus, but a point-to-point digital communication protocol.

**Solenoid Direct Operated**

Available in both D03 and D05 mounting patterns, the direct operated valves can be supplied for circuits requiring 2 or 3 positions, as well as 3-way or 4-way functions. The valve body is made with high strength cast iron and internal passages designed to minimize pressure drop.

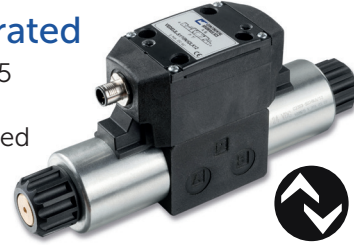

**Solenoid Pilot Operated**

Pilot operated directional control valves are available with either electric solenoid or hydraulic actuation of the main spool. The valves are available in both 2 or 3 position and various spool flow patterns. Configurable for internal or external pilot/drains and options for pilot pressure reducing, pilot chocks, and main stage stroke adjustments



**Spool Positioned Monitored and Kits**

Used as a component to help meet compliance with current machine safety standards. They are only one part of an overall system and are intended to be combined with other safety rated components to provide energy isolation and/or energy dissipation.



**Hazardous Location**

Special provisions used in the solenoids, allow these products to meet the following area classifications: ATEX EX d IIC, CSA, CE.

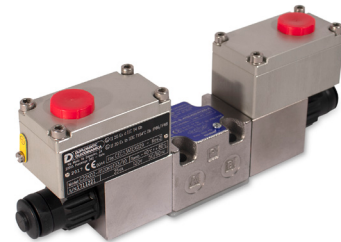

**Pneumatic – Hydraulic – Manually Operated**

Additional operators to help meet a variety of operator interface requirements. Operator interfaces include choices of Air, Hydraulic, Levers and Cams.



# VALVES: PROPORTIONAL

High speed precision with digital electronics

Continental offers a complete range of proportional valves: pressure control, flow control, directional, explosion-proof, high response. The various models are available with or without on-board electronic (OBE), feedback and in closed loop as well as field-bus and IO-Link configurations. Along with proportional valves, we also offer many digital electronic cards for both open and closed loop applications. Efficiency, speed, accuracy, repeatability and the chance to program the control are only some of the many benefits of proportional technology on electro hydraulics applications. Moreover, proportional components allow to speed up processes while reducing wastes and errors margins.

**Key Features:**

- With or without on-board electronics
- Multiple flow ranges to match your requirements
- Durable and incredible performance
- Digital electronics

**Applications:**

- Position Control
- Velocity Control
- Force/Pressure Control
- Lumber and Forestry
- Industrial Machine Automation

**High Performance Servo-Proportional**

Both High Speed Direct Operated as well as High Speed Dual Feedback Pilot Operated Proportional Directional Control Valves. Two types of integrated electronics are available, with analogue or field-bus interfaces.

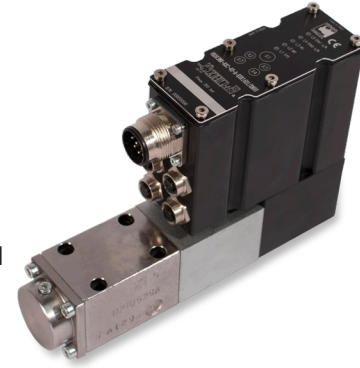

**Directional Control without On-Board Control**

These valves are designed to control the direction and oil flow rate based on the amount of current supplied to the solenoid. Valve solenoids can be driven by variable current power supply or use of external power amplifier cards designed to maximize the performance.



**Directional Control with On-Board Control**

**G Series:** On-Board proportional valves available in Direct Operated as well as Pilot Operated Proportional Directional Control Valves. Three types of digital integrated electronics, with analog, IO-Link or fieldbus control interfaces.

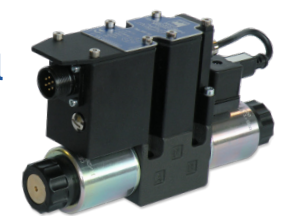

**Directional Control with Feedback**

**J Series:** On-Board proportional valves with Spool Position Feedback. For applications requiring highly responsive and accurate motion control. Three types of Digital integrated electronics with analog, IO-Link or field-bus control interfaces.

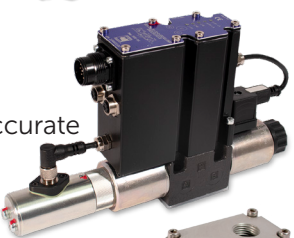

**Hazardous Location Proportional Valves**

These explosion proof valves are available in size ISO 4401-03 for direct operated type. Pilot operated valves are available in CETOP P05, ISO 4401-05, ISO 4401-07, ISO 4401-08 and ISO 4401-10 sizes.

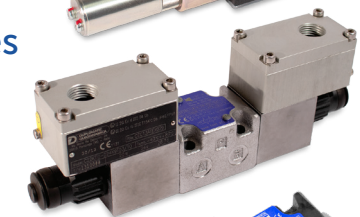

**Compensated Proportional Flow Control**

EDF03M and EDF05M are direct operated normally closed proportional flow control valves with pressure compensation. Used to regulate flow in a hydraulic circuit. Output flow is directly proportional to the input current to the solenoid.



**Proportional Valves - Pressure Control**

Available for Relief Valve and Pressure Reducing Valve functions. A large product offering in flow and pressure ranges make these valve the perfect choice wither you need with or without On-Board control, open loop or closed loop.



**Electronics - Open/Close loop control modules**

Large selection of motion controls. Variety of control interface options: Analog Voltage or Current / IO Link Ethernet IP / EtherCAT / Profinet / PROFIBUS DP / CAN Open / Powerlink



# VALVES: MODULAR STACK

## Flow, check and pressure controls

Modular stack valves are designed to install between the valve and its mounting surface. This will eliminate plumbing connections and reduce space requirements. Continental has a full range including check, flow control, relief, reducing, sequencing, shuttle valves and counterbalance valves. Manufactured to NFPA and ANSI/ISO's standards

Modular stack valves allow for many circuit function components to be easily mounted in a very economical, no leak package. With all functions located in a single convenient space, adjustments can easily be made. Functions include checks, flow controls, pressure controls, load holding and solenoid operated blocking valves.

### Key Features:

- High flow rates with low pressure drop
- Numerous functions and flow / pressure ranges
- NFPA D03 and D05 mounting
- Aluminum body products rated up to 3000 PSI
- Cast Iron body products rated up to 5000 PSI

### Applications:

Industrial Machinery  
Oil and Gas/Mining  
Food and Beverage  
Lumber and Forestry  
Power Generation

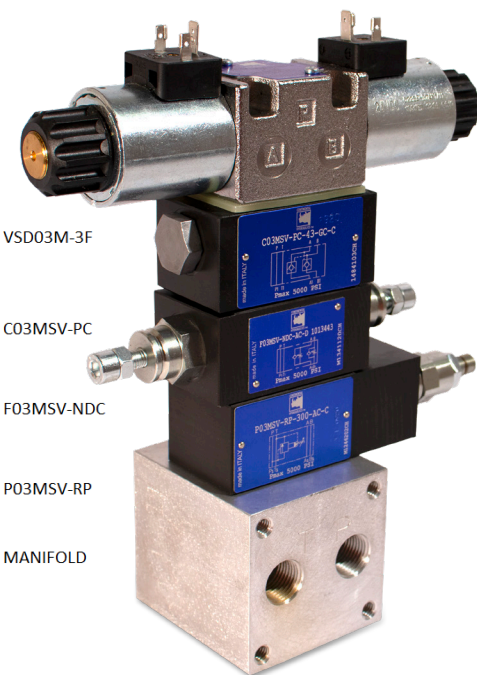
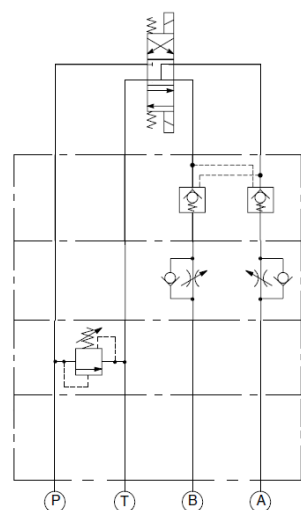

Schematic to assembly - compact and simple.

## Pressure Control Valves

Used to control all aspects of the system pressure or circuit pressure control, these modular stack valves are available in relief, pressure reducing and sequence functions.



## Flow Control Valves

Modular stack valves designed for control of output flow rates. Non-compensated flow control valves are made of cast iron bodies and pressure compensated flow controls are made with aluminum.

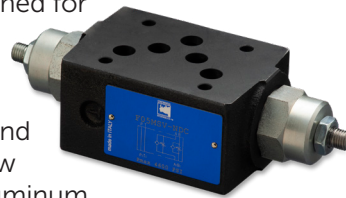

## Check Valves

This series of valves are a direct check valve made as a modular stack version with mounting surface according to the NFPA and ISO 4401 standards. — It is used to avoid oil backflows and self-emptying of lines, or to generate back-pressures.



## Blocking Valves

This modular stack valve is designed to help block oil movement both from the control valve or from the actuator. Typically used with proportional valves with zero-lap type spool configurations that could allow oil movement when the system is shut down.

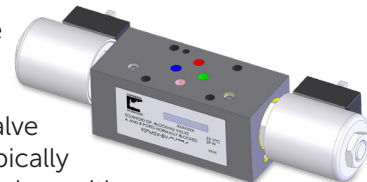

## Load Holding Valves

These modular stack valves utilize a cartridge type, guided poppet, hydraulic operated, pilot assisted, counterbalance valves or pilot operated check as a blocking or load-holding device for applications requiring locking and holding the load in any position.



# POWER UNITS

Standard / Custom Hydraulic PU's with a wide variety of options to meet any application

Continental has earned their outstanding reputation for high quality, long lasting power units over the last 59 years as a result of:

- International standard design and/or customized to your specific application.
- Engineering support, with drawings and documentation.
- Long life, low warranty and distribution support.
- Built for light duty and heavy, continuous duty for today's harshest environments.
- Tank capacity: 1 to 5000+ gallons in steel, stainless steel or aluminum.
- For fast, easy, setups, all power unites are shipped 100% tested.

### KEY FEATURES:

- System flow up to 500 GPM, and pressure to 5000 PSI
- Test up to and beyond 200 HP including international voltages
- Fluids and compatible seals, water glycol, phosphate ester, mineral, ATF, and more
- Motor starters with system accessories.
- Drawings in SolidWorks format or AutoCAD DWG/DXF.
- Assemblers are CFPS with over 20 years experience each
- 18 months warranty on power units, 36 months on Continental components.
- Motor controls and panels
- Documented and Tested 100%
  - Epoxy painting

### Applications:

- Sleeve bearing lubrication, cement plants, refineries and power plants
- Sand cast mold and match plate machine
- Water treatment plant - basin scraper
- Utilized to control a multi-axis missile guidance system testing fixture
- Automotive high speed cut-off application on rolling mills
- Solar energy panel control and hydroelectric dam valve control



Custom units engineered to fit specific locations. Tandem pumps mounted for easy inspection and maintenance.

## Standard Units

### Little Champ

Designed for where space is limited. They're ideal for applications requiring moderate fluid volume and flow rate, short hydraulic lines, and quick cycling. Little Champ power unit can be built at your facility at your convenience. Continental will supply the complete set of components and hardware.



### Low Profile

Option suited for applications with moderate fluid volume and flow rate. Solution where space is premium, or power of a NFPA/JIC-Style unit is needed in a smaller, less expensive package.



### NFPA/JIC

Created for heavier duty, continuous-use industrial applications requiring design flexibility and rugged construction.



### L Shape

Ideal for high fluid volume and flow rate applications. Removable tank cover simplifies cleaning. Features flooded suction inlets eliminating the need for the pump to lift hydraulic fluid, reducing wear and tear.

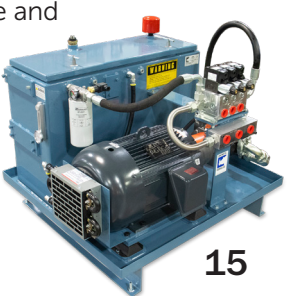



1800-OILSOL  
1800-645765

<https://oilsolutions.com.au/>

[sales@oilsolutions.com.au](mailto:sales@oilsolutions.com.au)

# DUPLOMATIC

MOTION SOLUTIONS

Since 1952 experts in hydraulics and motion control solutions.

Duplomatic MS is an innovative company capable of proposing engineering solutions for motion control and automation for industrial applications.

The headquarters are in Parabiago (MI), where valves are designed and manufactured, alongside the Hydraulic Systems Business Unit of Lainate (MI) and Padua for the construction of complex systems, the Business Unit Turnkey Projects of Parabiago (MI) for special and innovative turnkey projects and the Mechatronics Business Unit, with offices in Sulbiate (MB) for the development and production of electronic products with a view to Industry 4.0 and Rosta (TO) for the development and production of electric actuators.

Since 2020 Duplomatic MS is the only Italian company certified IO-Link Competence Center.

Duplomatic MS is also the holding company of the international Duplomatic group which includes Continental Hydraulics and Hydreco Hydraulics.

[duplomatic.com](http://duplomatic.com)

We are proud members of the **DUPLOMATIC** Group:



**Italy**  
Valves, Systems,  
Actuators

**United States**  
Valves, Pumps,  
Power Units

**UK, Italy, USA, Australia,  
India, Germany, Norway**  
Mobile: Valves, Pumps,  
Cylinders, Joysticks

**China**  
Valves



# ELECTRIC ACTUATORS / SERVO'S

Repeatability with built in power savings and smart controls at your fingertips

It's not the electrical cylinder that will set limits to your applications; it is rather your application characteristics that will determine the most suitable cylinder for your projects.

Thanks to a complete range of possible combinations of sizes, accessories, type of screws, motors and drives,

### Key Features:

- Customizable solutions
- Cylinders equipped with in-line or parallel motors
- Different types of screws for motion transmission
- Up to 22 tons of force, speeds to 50 inch per sec.
- Variety of drives and motors:
  - Stepper, Brush/Brush-less, DC Motors
  - Torque, speed and positioning control
  - Programmable digital inputs and outputs

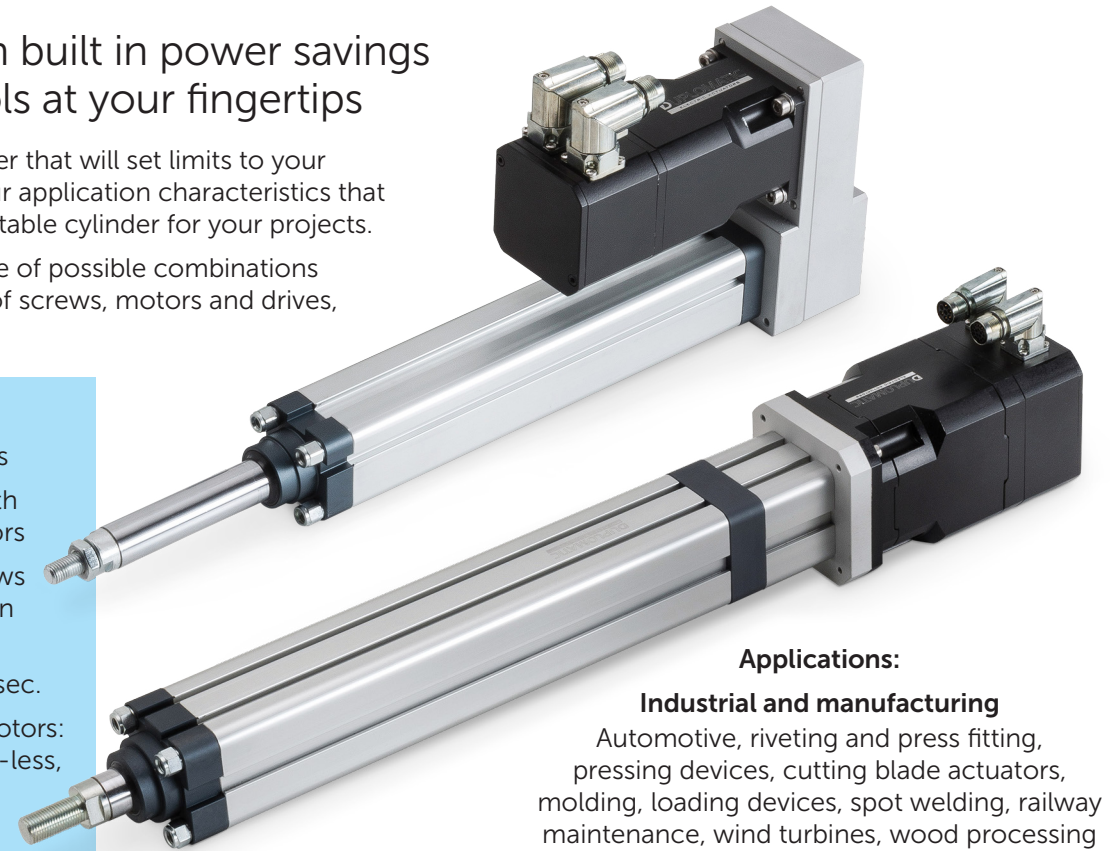

### Applications:

#### Industrial and manufacturing

Automotive, riveting and press fitting, pressing devices, cutting blade actuators, molding, loading devices, spot welding, railway maintenance, wind turbines, wood processing

#### Food, beverage and pharmaceutical

Dosing of liquid products, pick and place, slicing machineries, packaging, opening/closing doors



### Servo Motors

Brush-less motors made to offer a wide range of sizes, rated power, supply voltages and feedbacks. They are robust effective, and suitable for most industrial applications.

### Servo Drives

- In torque control mode, with analog input +10V
- In speed control mode, with analog input +10V
- In position control mode: Pulse+, CCW+ CW, A+B phase (5V-24V)

Digital inputs are available to set the drive at the optimum performance for the specific application. As an example, it is possible to enable or reset the drive, select the control mode, switch electronic gear ratio, switch gain, set the homing position, a quick stop, set end-stops, etc. Digital output can be used to monitor axis status..



# Making the difference at Continental & Hydreco

At Continental and Hydreco, we have built our reputation on four pillars that make our company different: People who care, who deliver engineering excellence and application know-how, all while being easy to do business with.

From hydraulics to motion solutions, from the Mid-West to the World, from analogue control logics to computerized electronics and AI, we are riding the wave of technology in our fast-changing markets.

Continental and Hydreco have been at the forefront of power transmission innovation for over 60 years and is – a leading force in transforming the industrial and mobile world we live in.



## Global Support

As a member of the Diplomatic Group our distribution and service network is quick, reliable, and responsive to our customer's needs. Rest assured that no matter where you're located, we will be there with unrivalled products and technical expertise.



## Technical Support

Quality products are only part of Continental Hydraulics and Hydreco's commitment to our customers. We also provide advisory, planning, and design services specifically geared to your application and backed by on-time delivery, full repair and test facility capabilities.



## Exceptional People

Continental and Hydreco engages and inspires their workforce to deliver on our four pillars of difference, providing the very best in what we do. Our culture, like everything at Continental and Hydreco, is made possible by each employee's contribution as a unified team.

# INDUSTRIAL AND MOBILE HYDRAULICS



1800-OILSOL <https://oilsolutions.com.au/>  
1800-645765

[sales@oilsolutions.com.au](mailto:sales@oilsolutions.com.au)



PROUD MEMBER OF THE **DIPLOMATIC GROUP**  
MOTION SOLUTIONS

CONTINENTAL HYDRAULICS INC. / HYDRECO INC.

4895 12th Avenue East, Shakopee, Minnesota 55379

952.895.6400 • [sales@conthyd.com](mailto:sales@conthyd.com) • [www.continentalhydraulics.com](http://www.continentalhydraulics.com)

704.295.7575 • [sales-us@hydreco.com](mailto:sales-us@hydreco.com) • [www.hydreco.com](http://www.hydreco.com)

