

Sytronix DRn 5020

Variable-Speed Pump Drive System

Quick Start Guide
R912007127

Edition 07



Record of Revision

Edition	Release Date	Notes
DOK-RCON03-DRN5020****-QU01-EN-P	2016.07	Preliminary
DOK-RCON03-DRN5020****-QU02-EN-P	2017.06	Added new functions
DOK-RCON03-DRN5020****-QU03-EN-P	2017.09	Added new functions
DOK-RCON03-DRN5020****-QU04-EN-P	2018.01	Added new functions
DOK-RCON03-DRN5020****-QU05-EN-P	2019.03	Added new functions
DOK-RCON03-DRN5020****-QU06-EN-P	2021.03	Added new functions, general revision
DOK-RCON03-DRN5020****-QU07-EN-P	2021.11	Deleted functions

Introduction of this documentation

This **Quick Start Guide** is derived from the **Operating Instructions** which include the product data.

WARNING

Personal injury and property damage caused by incorrect application, installation or operation!

Never work with or control the product before reading

- **Safety Instructions** delivered with EFC x610
- Safety descriptions in the **Operating Instructions**

Reference

For documentation available in other form or language, please consult your local sales partner or check www.boschrexroth.com.

Copyright

© Bosch Rexroth (Xi'an) Electric Drives and Controls Co., Ltd. 2021

All rights reserved, also regarding any disposal, exploitation, reproduction, editing, distribution, as well as in the event of applications for industrial property rights.

Liability

The specified data is intended for product description purposes only and shall not be deemed to be a guaranteed characteristic unless expressly stipulated in the contract. All rights are reserved with respect to the content of this documentation and the availability of the product.

Table of Contents

	Page
1	Type code..... 1
1.1	Pump controller type code description..... 1
1.2	DRn 5020 ASF type code description..... 2
1.3	Pertinent parameters..... 3
1.4	Abbreviations..... 4
2	Scope of supply..... 5
3	Documentation reference..... 6
4	Function specification..... 7
5	Getting started quickly..... 9
6	Start-up sequence..... 12
7	IO configuration and settings..... 13
7.1	Overview and electrical connection..... 13
7.2	Restoring ASF parameters..... 14
7.2.1	General..... 14
7.3	Analog inputs..... 15
7.3.1	General..... 15
7.4	Analog output AO1..... 17
7.5	Digital inputs..... 18
7.6	Digital and relay outputs..... 19
7.7	Loading pump parameters..... 19
7.8	Auxiliary pump..... 20
7.9	Motor parameters..... 21
7.9.1	Preconfigured motor parameters..... 21
7.10	Configuration of pressure transducer..... 24
8	Main functions..... 25
8.1	Maximum speed limitation..... 25
8.2	Minimum speed limitation..... 27
8.3	Pressure command value..... 27
8.3.1	General..... 27
8.3.2	Pressure command value sources..... 27

	Page
8.3.3 Pressure command learning.....	29
8.4 Speed adaption.....	30
8.4.1 General.....	30
8.4.2 Preferred swivel angle.....	31
8.4.3 Controller settings.....	31
9 Extended functions.....	32
9.1 Motor derating/fan monitoring.....	32
9.2 Speed masking.....	35
9.3 Motor stall monitoring.....	36
9.4 Sleep/wake-up function.....	37
9.5 Boost function.....	38
9.6 Oil heater/cooler.....	38
9.6.1 General.....	38
9.6.2 Digital oil temperature monitoring.....	38
9.7 Oil level monitoring.....	39
9.8 Swivel angle measurement.....	39
9.8.1 General.....	39
9.8.2 Fine adjustment.....	39
9.9 Oil filter monitoring.....	40
9.10 LED flash indicating converter status.....	40
9.11 Oil change warning/error function.....	41
10 Fieldbus communication.....	42
10.1 Brief introduction.....	42
10.2 Command values MDT.....	42
11 DRn 5020 parameter list.....	43
11.1 Terminology and abbreviations in parameter list.....	43
11.2 Group F1: Quick start parameters.....	44
11.3 Group F2: Input and output parameters.....	45
11.4 Group F3: Controller parameters.....	48
11.5 Group F4: Motor and pump settings.....	49
11.6 Important EFC parameters.....	50
11.7 Auto-modified EFC parameters in ASF initialization.....	51
12 Diagnosis.....	52
12.1 Warnings.....	52
12.2 Error codes.....	55

	Page
12.3 Monitoring parameters.....	57
Index.....	59

1 Type code

1.1 Pump controller type code description

Type short description	1	2	3	4	5	6	7	8	9	0	1	2	3	4	5	6	7	8	9	0	1	2	3	4														
Example:	E	F	C	5	6	1	0	-	1	5	K	0	-	3	P	4	-	M	D	A	-	7	P	-	D	R	N	N	N	N	-	N	N	N	N	N	N	N
Product EFC.....= EFC																																						
Power E.g., 15 kW.....= 15K0																																						
Phases Three phases.....= 3P																																						
Mains connecting voltage 400 V (380... 480VAC -15% / +10%).....= 4																																						
Communication module Modbus.....= M																																						
EMC filter Industrial area, class C3.....= D																																						
Degree of protection IP 20.....= A																																						
Display 7-segment display with potentiometer.....= 7P																																						
Specific variant Sytronix functionality DRn.....= DRNNN None.....= NNNNN																																						
Other design None.....= NNNN Safe Torque Off.....= L1NN																																						

Fig. 1-1: EFC 5610 type code

This type code can be found on the Rexroth EFC converter.

1.3 Pertinent parameters

Parameter	Name	Value
F0.01	ASF version	*
F0.02	ASF identifier	C14
F0.03	ASF API required version	*
F0.06	ASF evaluation time	*
F0.07	ASF API version	*
F0.10	ASF status	Bit0: ASF valid
		Bit1: API compatible
		Bit2: ASF certified
		Bit3...Bit7: Reserved
		Bit8: ASF evaluation period expired
		Bit9: ASF invalid
		Bit10: ASF API incompatible
		Bit11: Reserved
		Bit12: ASF runtime exceeded
		Bit13: ASF stack overflow
	Bit14...Bit15: Reserved	

Tab. 1-1: DRn 5020 ASF basic information



*: For accurate information, refer to the actual data provided on the product.

API: Application Program Interface

1.4 Abbreviations

The following abbreviations are used in this documentation:

Abbreviation	Meaning
AI1, AI2...	Analog input
AO1	Analog output
ASF	Application-Specific Firmware, application control software for EFC frequency converter
DO1	Digital output
DR	Pump-integrated mechanical pressure controller
DRn system	Variable-speed pump system
EAI	Analog input on extension card
EAO	Analog output on extension card
EDO	Digital output on extension card
EFC	Frequency converter
EX1, EX2...	Digital input on extension card
GUI	Graphical user interface
n	Speed
p	Pressure
Q	Flow
X1, X2...	Digital input

Tab. 1-2: Abbreviations

2 Scope of supply

If any item is found missing from standard supply package as listed below, please contact Bosch Rexroth's local sales partner at your earliest convenience.

- Frequency Converter EFC 5610 with integrated Sytronix software
- Safety Instructions (available in multiple languages)
- EFC 5610 Quick Start Guide
- DRn 5020 ASF Quick Start Guide

3 Documentation reference

Following documentations about the components can be found on the Bosch Rexroth homepage via the product catalog or directly via the following link:

www.boschrexroth.com/mediadirectory

Title	Document number	Document type	Catalog
Frequency-Controlled Pump Drive System Sytronix DRn 5020	R912004808	Operating instructions	Pump systems
Frequency-Controlled Pump Drive System Sytronix DRn 5020	RE 62319-FK	Functional description	Pump systems
Rexroth Frequency Converter EFC 3610 / EFC 5610 Series	R912005856	Quick Start Guide	Controller / converter
Rexroth Frequency Converter EFC 3610 / EFC 5610 Series	R912005854	Operating instructions	
Pressure transducer for hydraulic applications, type HM20	RE 30272	Data sheet	Pressure sensor
Rexroth MOT-EC Motors	In preparation	Project Planning Manual	Motor

Tab. 3-1: Documentation reference

4 Function specification



This document only describes the Sytronix function that has been integrated in DRn 5020 ASF. For information on basic converter functions, please refer to EFC 5610 documents.

Pressure-compensated variable displacement pumps (e.g., Rexroth A4, A10) normally deliver a controlled pressure in a hydraulic system. A hydro-mechanical pressure controller ("DR" or "DRG") is used to adjust the pressure level of the pump output. The variable displacement pump only delivers as much hydraulic fluid as required to maintain a specific pressure. If the system pressure rises above the pressure command value, the pump displacement is reduced until the pressure falls back to the proper level. If the system pressure falls, the pump displacement is increased to raise the pressure again to the proper level.

The "Sytronix DRn" functionality is a control algorithm that modifies the pump speed, as needed, as opposed to operation at a constant speed. Model-based algorithms are used to optimize energy efficiency and greatly reduce ambient noise. The DR/DRG pump pressure controller retains its function as primary controller of system pressure.

To use "Sytronix DRn", at least an actual pressure value as well as a preferred swivel angle value for the relative pump volume have to be made available to the drive. As an option, the optimization of the internal models can be improved by providing a pressure command value or an actual displacement value.

The speed adaptation works independently of the pressure control that is still carried out with the hydro-mechanical DR/DRG controller. In particular, the hydraulic circuit and the mechanical construction of the machine remain unaffected. Therefore, the "Sytronix DRn" technology function is suited both for upgrading existing installations within the scope of retrofit and for designing new machine generations.

"Sytronix DRn" has been designed for pressure control systems. In conjunction with remotely operated pressure control (Rexroth DRG) or pressure and flow control (Rexroth DFR), it is necessary to check whether or not the technology function is suited for the application at hand.

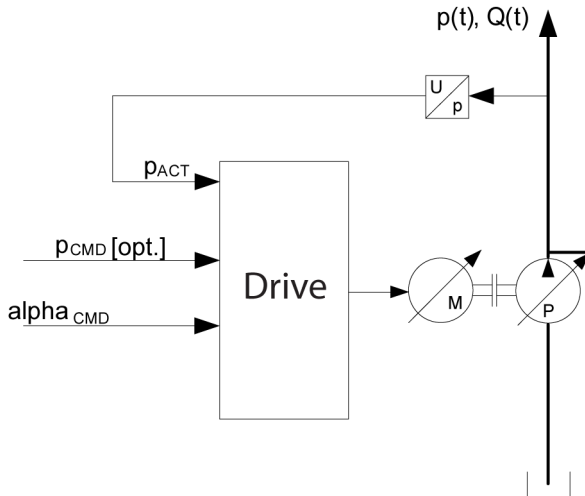

Fig. 4-1: System principle

The product provides the following features.

- Speed adaption of pressure-controlled DR/DRG pumps to improve energy efficiency and noise emission
- Automatic boost function to reduce pressure drops in load switching conditions
- Automatic motor derating to ensure cooling power at lower motor speeds
- Speed masking to avoid defined speed ranges to improve noise emission
- Auxiliary pumps for oil cooling or filtering can be handled by "Sytronix DRn"
- Protection functions
 - Detection of pressure drops
 - Limiting maximum pump speed
 - Limiting maximum pump acceleration
 - Wire break detection for current sensors
 - Oil change warning / error
 - Pump thermal protection
 - Sensor monitoring for oil temperature, oil level and oil filter
- Pressure signal feedback
 - Compatible with multiple types of pressure sensors (flexible scaling for the analog input signal)
 - Highly resistant to electromagnetic interference (with the use of high-precision digital filter device for signal filtering)

- Quick configuration for Rexroth HM20 pressure transducer
- Quick configuration for Rexroth MOT-EC_HOY motor
- Evaluation of a swivel angle sensor (AWAX, SWS20) is possible
- Extension functions
 - Sleep / wake function
 - Control of oil cooler or oil heater

5 Getting started quickly

If you are already familiar with the DRn 5020 Sytronix system you can use this description to get started quickly with your system.

#0: Documentation

To get access to the latest documentation from the Bosch Rexroth, visit

<https://www.boschrexroth.com/mediadirectory> and enter the document number in the search window.

R912004808: Operating Instructions DRn5020

R912005854: Operating instructions for EFC 3610/EFC 5610 series

R912006860: Frequency Converter, Multi-Ethernet Card, Instruction Manual

For more information regarding referenced documentation, see [chapter 3 "Documentation reference" on page 6](#).

#1: Download IndraWorks Ds

For operation of the DRn 5020 system you require IndraWorks Ds which can be downloaded <https://www.boschrexroth.com/ics/cat/?id=&cat=Electric-Drives-and-Controls-Catalog&o=Desktop&p=p693045>.

#2: EFC 5610 wiring for DRn 5020 operation

For wiring, see [chapter 7.1 "Overview and electrical connection" on page 13](#).

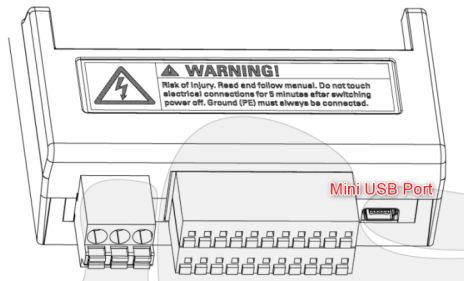
#3: Connect the PC via USB interface to EFC 5610**Fig. 5-1:** USB connection of EFC 5610**#4: Connect IndraWorks Ds with EFC 5610**

For detailed information, see Functional Description RE 62319-FK.

#5: Select "Basic commissioning" in IndraWorks Ds

For detailed information, see Functional Description RE 62319-FK.

#6: Load default parameters

Restore with option "Base device non fieldbus and non fieldbus options" and load the Default Parameters in a second step. For detailed information, see [chapter 7.2 "Restoring ASF parameters" on page 14](#).

#7: Master communication

1. Select bus system and press "Reboot".
2. Set IP-address according to the PLC address range.
3. Configure process data, see Functional Description RE 62319-FK.

#8: Set motor parameters - three possibilities

1. MOT-EC-HOY is used → see #9 below
2. Third-party motor is used and ECD (equivalent circuit diagram) data are available → see #10 below.
3. Third-party motor, but only nameplate data are available → see #10 below.

#9: MOT-EC-HOY

Set F1.15 = 1 and select the corresponding motor power level in F1.16.

For more detailed information, see [chapter 7.9.1 "Preconfigured motor parameters" on page 21](#).

#10: Get ECD (equivalent circuit diagram) parameters for motor from manufacturer and enter them in the dialog

Afterwards do not execute motor auto-tuning!

For more detailed information, see Functional Description RE 62319-FK.

#11: Execute motor auto-tuning only, if ECD data are not available

Execute "rotational auto-tuning".

For more detailed information, see Functional Description RE 62319-FK.

#12: Set temperature sensor via parameter editor

For detailed information, see Functional Description RE 62319-FK.

#13: Select pump from drop down menu

Select the relevant pump type in F4.29. If the pump type is not available, set F4.29 = 0 and make the manual input via F4.30...F4.54.

If the relevant pump type is not available, select "Manual".

For more detailed information, see [chapter 7.7 "Loading pump parameters" on page 19](#).

#14: Select pressure transducer type

If the desired type is not available, select "other type" and enter nameplate data.

For more detailed information, see [chapter 7.10 "Configuration of pressure transducer" on page 24](#).

#15: Select swivel angle sensor, if used

If you use a swivel angle sensor, select the type.

For more detailed information, see [chapter 9.8 "Swivel angle measurement" on page 39](#).

#16: Set pressure command value

- The default setting is "fixed value". For applications with more than two changes in the pressure command value we recommend changing the value via bus communication instead of learning.

For detailed information, see [chapter 8.3 "Pressure command value" on page 27](#).

#17: Set minimum and maximum speed

For detailed information, see [chapter 8.1 "Maximum speed limitation" on page 25](#) and [chapter 8.2 "Minimum speed limitation" on page 27](#).

#18: Set DRG controller

Set the correct pressure command value at the DRG controller on the pump.

For details, see operating instructions for DRn 5020.

#19: Check direction of rotation

Notice: Rotating the pump in reverse direction is allowed only briefly for less than 200 ms. Otherwise, the pump could be destroyed.

1. The pump nameplate shows the allowed direction of rotation (viewed to the motor shaft).
2. The pump needs to be filled with hydraulic fluid before operation!
3. Set motor speed to 400 rpm → see maximum speed limitation, [chapter 8.1 "Maximum speed limitation" on page 25](#).
4. Operate pump in "DRn enable mode", see [chapter 6 "Start-up sequence" on page 12](#).
5. Operate the pump only briefly!
6. Check the direction of rotation of the motor fan or check that pressure builds up.



Fig. 5-2: Nameplate with direction of rotation arrow

If the pump rotates in the wrong direction, check that E0.17 = 3. If this setting is correct, change wiring of the motor.

#20: Fine tuning

1. Reduce pressure drops by means of the boost function.
2. Define threshold, when motor should accelerate to compensate the pressure drop.

For detailed information, see [chapter 9.5 "Boost function" on page 38](#).

6 Start-up sequence

To use the whole functionality of a DRn 5020 system it is in general necessary to use three signals. These signals can be set using digital inputs or via a fieldbus communication.

1. Enable the drive - RUN command.

The drive is enabled but no speed command value is provided. The motor stands still with the speed command value "zero rpm".

2. Run the pump in DR control - DRn enable

The motor accelerates linearly to maximum speed in the start-up time, which is set in F3.29. The maximum speed can be set variably over field

bus, or via an analog input, or with fixed values stored in the pump controller (F3.20, F3.30).

3. Activate speed adaptation - DRn variable speed enable

The pump controller will now try to keep the swivel angle of the pump at a particular value.



A combination of RUN command with DRn enable and variable-speed enable which could be set in F2.15 is only available when digital inputs are used, not with fieldbus.

7 IO configuration and settings

7.1 Overview and electrical connection

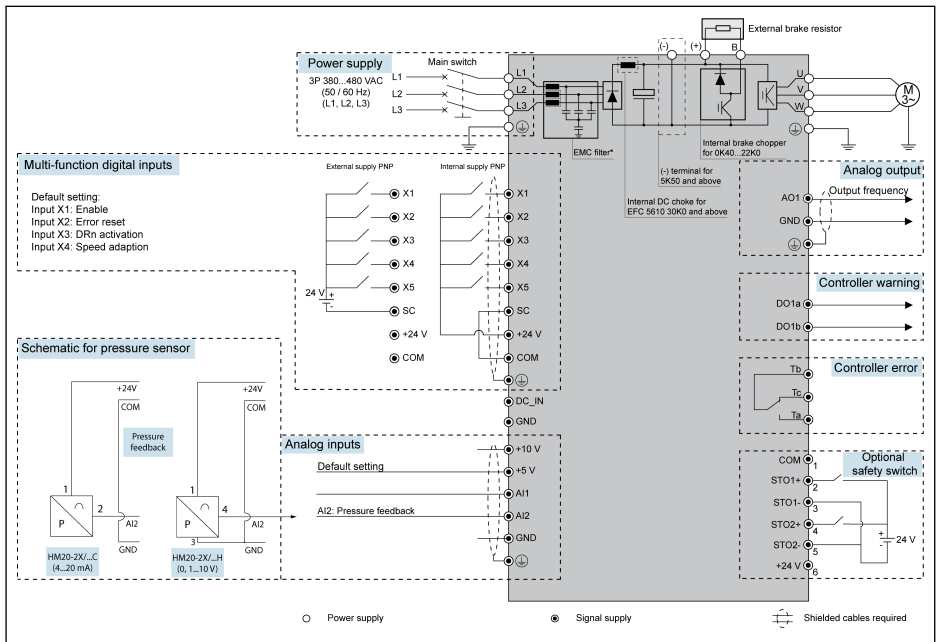

Fig. 7-1: Wiring diagram



- The DRn 5020 I/O functionality is given priority over standard EFC functions. The standard EFC functionality assigned to the terminal will be ignored and taken over by the ASF terminal assignment (non-zero entries in ASF).
- For details about wiring of the temperature sensor, please refer to EFC 5610 operating instructions (R912005854).
- Avoid connection between GND and COM for disturbance reasons. For example, in Sytronix applications the HM20 pressure transducer should be supplied by external 24 V, and all digital I/O by internal 24 V.

7.2 Restoring ASF parameters

7.2.1 General

You can restore the ASF parameter setting to default via F1.00. By doing this the following EFC parameters will be re-set to ASF default values as well. Please refer to [chapter 11.7 "Auto-modified EFC parameters in ASF initialization"](#) on page 51 for more details.

Additionally, if b0.10 is executed to restore EFC parameters, please make sure to re-execute F1.00 = 1 to restore all ASF parameters to default values.

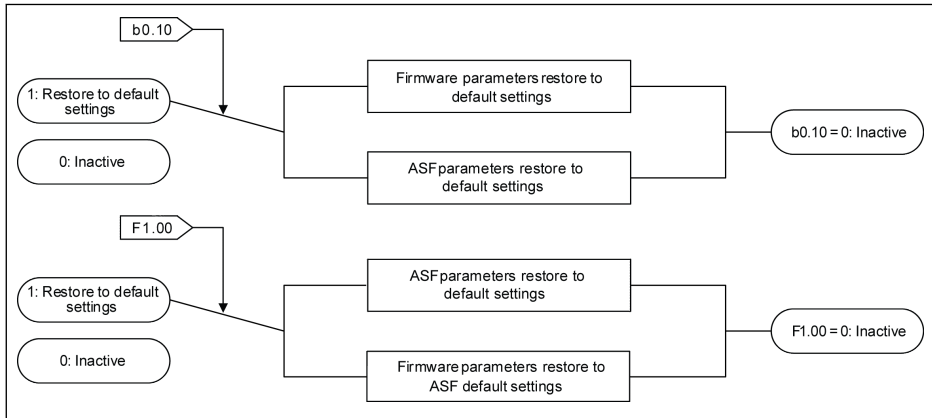

Fig. 7-2: ASF parameter restore to default



By restoring ASF parameters (setting F1.00 = 1), the values of parameters F1.15 and F1.16 will NOT be restored.

7.3 Analog inputs

7.3.1 General

This section shows how analog inputs can be configured. The following figure is an example of analog input AI2, which has been assigned to pressure feedback. The configuration for AI1, EAI and EAI2 is similar to AI2, only with different parameters as shown in the table below.

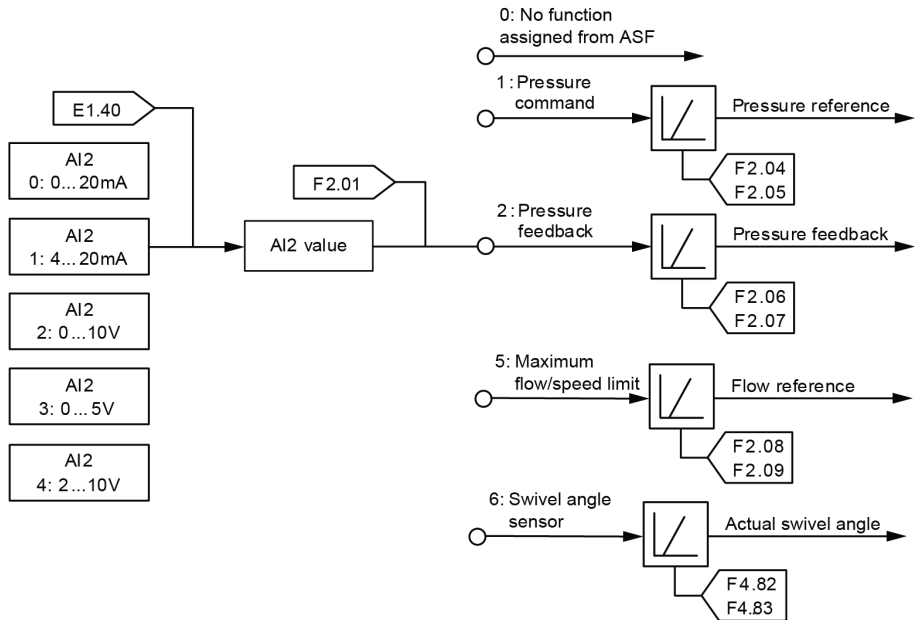

Fig. 7-3: Example with analog input AI2 assigned to pressure feedback

Code	Name	Setting range	Default	Min.	Attri.
E1.35	AI1 input mode	0: 0...20 mA	2	-	Run
E1.40	AI2 input mode	1: 4...20 mA 2: 0...10 V 3: 0...5 V 4: 2...10 V	1	-	Run
H8.05	EAI input mode	0...4 (same as E1.35) 5: -10V...10V	0	-	Stop
H8.30	EAI2 input mode	0...4 (same as E1.35) 5: -10V...10V	0	-	Stop

Code	Name	Setting range	Default	Min.	Attri.
F2.00	Analog input AI1	0: No function assigned	0	-	Stop
F2.01	Analog input AI2	1: Pressure command	2	-	Stop
F2.02	External analog input EAI (-10V...10V, 4...20mA)	2: Pressure feedback	0	-	Stop
F2.03	External analog input EAI2 (-10V...10V, 4...20mA)	5: Maximum flow/speed limit 6: Swivel angle feedback	0	-	Stop

Tab. 7-1: Analog input parameter list

In the default DRn 5020 configuration, analog input AI2 [F2.01 = 2] is configured as the pressure feedback input. Analog input AI1 or EAI/EAI2 has no preassigned configuration by the DRn 5020.

The analog inputs F2.00...F2.03 are mutually exclusive and therefore do not allow for any identical setting (except 0) between the parameters. When a repeated non-zero value is entered, the former will reset to 0 automatically, i.e. the last entered value takes effect.



Setting more than one input to the same function is not allowed. By doing this the very last change will be kept, but other conflicting parameters will be set to 0. For example, by setting F2.00 = 1 and then F2.01 = 1, the value of F2.00 will be reset to 0 automatically.

7.4 Analog output AO1

There is no function assigned to AO from DRn ASF. For details about the analog output option of the EFC basic firmware, please refer to EFC 3610 / EFC 5610 Operating Instructions (R912005854), see parameters E2.25 and E2.26.

Code	Name	Setting range	Default	Attri.
E2.25	AO1 output mode	0: 0...10 V 1: 0...20 mA	1	Run
E2.26	AO1 output setting	0: Output frequency 1: Setting frequency 2: Output current 4: Output voltage 5: Output power 6: AI1 analog input 7: AI2 analog input 8: EAI1 analog input 9: EAI2 analog input 11: Motor temperature sensor power supply 12: Parameter setting from communication 13: Setting torque 14: Output torque	0	Run

Tab. 7-2: Analog output AO1 parameter list

7.5 Digital inputs

Code	Name	Setting range	Default	Attri.
F2.16	X1 input	0: No function assigned by ASF	0 (Enable)	Stop
F2.17	X2 input	1: Pressure command selection bit0 2...3: No function	0 (Error Reset)	Stop
F2.18	X3 input	4: Flow limitation selection	10	Stop
F2.19	X4 input	5...9: No function	11	Stop
F2.20	X5 input	10: Activate DRn function	0	Stop
F2.21	EX1 input	11: Activate speed adaption	0	Stop
F2.22	EX2 input	13: Oil level warning	0	Stop
F2.23	EX3 input	14: Oil temperature warning	0	Stop
F2.24	EX4 input	15: Oil filter 1 pre-warning	0	Stop
F2.25	EX5 input	16: Oil filter 1 warning 100% 17: Oil filter 2 pre-warning 18: Oil filter 2 warning 100% 19: Oil level error 20: Oil temperature error 21: Suction valve closed error 22: Oil level warning inverse 23: Oil temperature warning inverse 24: Oil filter 1 pre-warning inverse 25: Oil filter 1 warning 100% inverse 26: Oil filter 2 pre-warning inverse 27: Oil filter 2 warning 100% inverse 28: Oil level error inverse 29: Oil temperature error inverse 30: Suction valve closed error inverse	0	Stop

Tab. 7-3: DI parameter list

The default setting of terminals X1 and X2 in ASF is '0'; this means when ASF is not active, the function of the DI setting in the EFC firmware is active. But part of the EFC firmware parameters, including [E1.00] = 35 (X1 set to 'Enable'), [E1.01] = 34 (X2 set to 'Reset'), are pre-set automatically in ASF.

The digital inputs F2.16...F2.20 are mutually exclusive and therefore do not allow for any identical setting between the parameters, otherwise warning APF1 will be triggered.

The default setting for terminal X1...X5, EX1...EX5 in ASF is "0". This means, no function from ASF is assigned, only assigned EFC firmware functions are active.

7.6 Digital and relay outputs

Code	Name	Setting range	Default	Attri.
F2.36	DO1 output	0: No function assigned from ASF 1: Pump controller warning 2: Green flashing LED 3: Red flashing LED	1	Run
F2.37	EDO output		0	Run
F2.38	EDO2 output		0	Run
F2.40	Relay 1 output		0	Run
F2.41	Extension relay output		0	Run

Tab. 7-4: Parameter list of digital and relay outputs

The DRn5020 default setting of DO1 is "1", i.e. pump controller warning. The function is assigned from the ASF.

On the other side, the settings for the relay outputs or digital outputs of the extension card are "0", which means that the function is assigned by the EFC firmware.

The EFC parameter E2.15 is set to "14" (pump controller error) by ASF as DRn default setting. For more EFC parameters that are changed as DRn default setting, please refer to [chapter 11.7 "Auto-modified EFC parameters in ASF initialization" on page 51](#).

7.7 Loading pump parameters

Before the speed adaptation of the "Sytronix-DRn" function can be used, it is necessary to set the data of the hydraulic pump.

Data for recommended pumps are stored in the ASF. They can be chosen via parameter F4.29.

F4.29	Pump type	F4.29	Pump type
0	Manual input see F4.30, F4.50, F4.51, F4.52, F4.53, F4.54	16	A10VSO100DR..S/32
1	A10VSO18DR/31 & A10VZO18DR/10	17	A10VSO140DR..E/32
2	A10VSO28DR/31 & A10VZO28DR/10	18	A10VSO140DR..S/32
3	A10VSO45DR/31	19	A10VSO180DR..E/32
4	HA10VSO45DR/31 & A10VZO45DR/10	20	A4VSO*40DR/10
5	A10VSO71DR/31	21	A4VSO*71DR/10
6	HA10VSO71DR/31 & A10VZO71DR/10	22	A4VSO*125DR/30
7	A10VSO100DR/31	23	A4VSO*180DR/30
8	HA10VSO100DR/31 & A10VZO100DR/10	24	A4VSO*250DR/30

F4.29	Pump type	F4.29	Pump type
9	A10VSO140DR/31	25	A10VZO10DR/10
10	HA10VSO140DR/31 & A10VZO140DR/10	26	A4VSO*335DR/30
11	A10VSO45DR..E/32	27	A10VZO180DR/10
12	A10VSO45DR..S/32	28	A4VSO*500DR/30
13	A10VSO71DR..E/32	29	No display
14	A10VSO71DR..S/32	30	A4VSO*750DR/30
15	A10VSO100DR..E/32	30	A4VSO*1000DR/30

Tab. 7-5: Selection of pump type

If you work with a pump which is not listed here you have to set F4.20 = 0 (Manual) and the following parameters.

Code	Name	Setting range	Default	Attri.
F4.30	Pump: Maximum displacement	1.0...5,000.0 ccm	18.0	Stop
F4.50	Pump: Maximum angular acceleration	0...60,000 rad / s ²	1,500	Stop
F4.51	Pump: Maximum speed	0...10,000 rpm	1,000	Stop
F4.52	Pump: Minimum speed	0...10,000 rpm	300	Stop
F4.53	Pump: Inertia mantissa	0...10,000 *	100	Stop
F4.54	Pump: Inertia exponent	0...10 *	5	Stop

Tab. 7-6: Parameter list of system configuration

*: F4.53 and F4.54 have no own dimension. The value calculated by the mantissa and exponent has the dimension kgm².

7.8 Auxiliary pump

If an auxiliary pump has been additionally mounted to the motor shaft (e.g., cooling circuit or filter circuit), the additional load has to be taken into account in speed adaption. For the internal calculation, the following parameters have to be configured:

Code	Name	Setting range	Default	Attri.
F4.59	Auxiliary pump: Displacement	0.0...5,000.0 ccm	0.0	Stop
F4.60	Auxiliary pump: Pressure	0.00...250.00 bar	0.00	Stop

Tab. 7-7: Parameter list of auxiliary pump

F4.59 Auxiliary pump: Displacement / F4.60 Auxiliary pump: Pressure

By means of the displacement and the pressure level of the auxiliary pump a torque offset is calculated internally for the load observer:

$$Torque\ offset [Nm] = \frac{Displacement [ccm] \cdot Pressure [bar]}{20 \cdot \pi \cdot \eta}$$

7.9 Motor parameters

7.9.1 Preconfigured motor parameters

The parameters of the MOT-EC-HOY motor are preconfigured in the ASF so that auto-tuning or motor parameterization are not required if the DRn 5020 application uses a preconfigured MOT-EC-HOY motor.

The settings for the motor can be made in the parameters F1.15 and F1.16. Please keep [F1.15] = 1 and set F1.16 to the corresponding power level as specified below.

Code	Name	Setting range	Default	Attri.
F1.15	Motor type	0: Others 1: MOT-EC-HOY	0	Stop
F1.16	Motor power level	0: No selection 1: Reserved 2: Reserved 3: Reserved 4: 0.75 kW 5: 1.1 kW 6: 1.5 kW 7: 2.2 kW 8: 3 kW 9: 4 kW 10: 5.5 kW 11: 7.5 kW 12: 11 kW 13: 15 kW 14: 18.5 kW 15: 22 kW 16: 30 kW 17: 37 kW 18: 45kW 19: 55 kW 20: 75 kW 21: 90 kW 22: 110 kW 23: 132 kW 24: 160 kW	0	Stop

Tab. 7-8: Motor parameter list



- Only change motor parameters by switching F1.16 to 1...24, when F1.15 = 1.
- If F1.15 = 0, no motor parameter will be changed by switching F1.16.



In older ASF versions below 02V16 the standard motor family MOT-FC was provided by the DRn 5020 system. From July 2021 on, the MOT-FC motors will no longer meet legal requirements for new applications with regard to the energy classification. The motors are therefore replaced by the new motor family MOT-EC.

7.10 Configuration of pressure transducer

For applications using the Rexroth HM20 pressure transducer, configuration parameters of the HM20 transducer can be automatically loaded by selecting the corresponding type code in parameter F2.10. Please make sure the right analog input channel has been set through [F2.00]...[F2.03] before setting [F2.10], since the configuration parameters (AI input mode and scaling factors) will be set for the selected channel for pressure feedback.

The pressure feedback is required to observe the hydraulic load and to trigger the automatic boost function of section 6.4. Therefore, analog input AI2 has to be configured with respect to the installed pressure transducer.

Code	Name	Setting range	Default	Attri.
E1.35	AI1 input mode	0: 0...20 mA	2	Run
E1.40	AI2 input mode	1: 4...20 mA 2: 0...10 V 3: 0...5 V 4: 2...10 V	1	Run
H8.05	EAI input mode	0...4 (same as E1.35) 5: -10...10 V	0	Stop
F2.00	Analog input AI1	0: No function assigned	0	Stop
F2.01	Analog input AI2	1: Pressure command	2	Stop
F2.02	Extended analog input EAI	2: Pressure feedback	0	Stop
F2.03	Extended analog input EAI2	5: Maximum flow/speed limit 6: Swivel angle feedback	0	Stop
F2.04	Pressure command corresponding to 10 V / 20 mA	0.1...1,000.0 bar	100.0	Stop
F2.05	Pressure command null offset in V or mA	0...5.0 V, mA	0.1	Stop
F2.06	Pressure feedback corresponding to 10V or 20mA	0.1...1,000.0 bar	100.0	Stop

Code	Name	Setting range	Default	Attri.
F2.07	Pressure feedback null offset in V or mA	0.0...5.0 V, mA	0.1	Stop
F2.10	Pressure sensor type	0: Others 1: HM20-2X/10-C 2: HM20-2X/50-C 3: HM20-2X/100-C 4: HM20-2X/160-C 5: HM20-2X/250-C 6: HM20-2X/315-C 7: HM20-2X/400-C 8: HM20-2X/630-C 9: Other 4...20mA pressure sensor 10: Reserved 11: HM20-2X/10-H 12: HM20-2X/50-H 13: HM20-2X/100-H 14: HM20-2X/160-H 15: HM20-2X/250-H 16: HM20-2X/315-H 17: HM20-2X/400-H 18: HM20-2X/630-H 19: Other 0.1...10V pressure sensor	3	Stop

Tab. 7-9: Parameter list of HM20 pressure transducer auto-selection

8 Main functions

8.1 Maximum speed limitation

The maximum speed limitation is the speed at which the pump runs when DRn mode is activated and speed adaption is deactivated. The system works with the mechanical pressure controller on the pump and maintains a constant speed.

The maximum speed limitation can be set in three different ways. The selection of the maximum speed limitation source has to be made in F2.14

Code	Name	Setting range	Default	Attri.
F2.14	Maximum flow limit source	0: Depends on the value of F2.13 1: Communication 2: Analog input 3: Select by digital input (F2.13 shows status)	0	Stop

Tab. 8-1: Maximum speed limitation**Fixed values**

In the pump controller two different maximum speed values can be stored. With one digital input it is possible to switch between these two values which are stored in F3.20 and F3.30. The digital input used has to be set to 4: Flow limitation selection. See chapter [chapter 7.5 "Digital inputs" on page 18](#).

Maximum speed command selection bit0 in digital inputs X1...X5, EX1...EX5	0	1
Maximum speed command selection F2.13	0	1
Active maximum speed from parameter	F3.20	F3.30

Tab. 8-2: Maximum speed limitation with fixed values**Analog value**

The analog inputs can be used to transmit a variable maximum speed value. The assignment for the analog input used is:

5: Maximum flow/speed limit

How to configure the analog input is described in [chapter 7.3 "Analog inputs" on page 15](#).

The settings for scaling have to be made in F2.08 and F2.09.

Code	Name	Setting range	Default	Attri.
F2.00	Analog input AI1	0: No function assigned	0	Stop
F2.01	Analog input AI2	1: Pressure command	2	Stop
F2.02	External analog input EAI (-10 V...10 V, 4... 20 mA)	2: Pressure feedback	0	Stop
F2.03	External analog input EAI2 (-10 V...10 V, 4... 20 mA)	5: Maximum flow/speed limit 6: Swivel angle feedback	0	Stop
F2.08	Flow command corresponding to 10 V or 20 mA	1...10,000 rpm	400	Stop
F2.09	Flow command null offset in V or mA	0.0...5.0 V, mA	0.0	Stop

Tab. 8-3: Parameter list of group F2

Field bus

The maximum speed limitation can be cyclically transmitted over a fieldbus system. The fieldbus master has to write the value on F0.23 (ASF command 4 ; Maximum flow limit). For more information, see Functional Description .

8.2 Minimum speed limitation

There are two reasons for setting a minimum speed in a DRn system. That's why two parameters are available for setting a minimum speed. The higher one is always active.

Code	Name	Setting range	Default	Attri.
F3.19	Speed adaptation: Minimum speed	0...10,000 rpm	300	Run
F4.52	Pump: Minimum speed	0...10,000 rpm	300	Stop

Tab. 8-4: Minimum speed limitation

Not every variable axial piston pump is able to run within the low-speed range (>200 rpm) in the pressure hold mode. To provide protection against overheating, a minimum pump speed has to be set in F4.52.

If the pump type was chosen via parameter F4.29, the correct minimum pump speed is set automatically from the ASF.

In speed adaption mode the speed range has to be limited, too. If the speed of an inductance motor is too low, the efficiency of the motor becomes quite poor. In this case, it is better to run at a larger swivel angle. The minimum speed is set in F3.19 and has a default value of 300 rpm.

8.3 Pressure command value

8.3.1 General

The pressure command value is necessary for utilizing the complete functionality of the DRn software. The pressure command value is compared with the actual pressure value to decide if the pressure boost function has to be activated.

8.3.2 Pressure command value sources

The pressure command value can be set in three different ways. The selection of the pressure command source has to be made in F1.02.

Code	Name	Setting range	Default	Attri.
F1.02	Control word: Pressure command source	0: Depending on the value of F1.04 1: Communication 2: Analog input 3: Learning pressure command 4: Select by digital input (F1.04 shows status)	0	Stop

Tab. 8-5: Control word of pressure command source

Fixed values

In the pump controller two different command values can be stored. With one digital input it is possible to switch between these two values, which are stored in F1.05 and F1.06.

The digital input used as to be set as follows:

1. Pressure command selection bit 0, see [chapter 7.5 "Digital inputs" on page 18](#).

Pressure command selection bit0 in digital inputs X1...X5, EX1...EX5	0	1
Pressure command selection F1.04	0	1
Active pressure command from parameter	F1.05	F1.06

Tab. 8-6: Pressure command selection

Analog value

The analog inputs can be used to transmit a variable pressure command value. The assignment for the used analog input is:

1. Pressure command

How to configure the analog input, see [chapter 7.3 "Analog inputs" on page 15](#).

The settings for scaling have to be made in F2.04 and F2.05.

Code	Name	Setting range	Default	Attri.
F2.00	Analog input AI1	0: No function assigned	0	Stop
F2.01	Analog input AI2	1: Pressure command	2	Stop
F2.02	External analog input EAI (-10V...10V, 4...20mA)	2: Pressure feedback	0	Stop
F2.03	Extended analog input EAI2 (-10V...10V, 4...20mA)	5: Maximum flow/speed limit 6: Swivel angle feedback	0	Stop

Code	Name	Setting range	Default	Attri.
F2.04	Pressure command corresponding to 5 V, 10 V or 20 mA	0.1...1,000.0 bar	100.0	Stop
F2.05	Pressure command null offset in V or mA	0...5.0 V, mA	0.1	Stop

Tab. 8-7: Analog values

Field bus

The pressure command value can be cyclically transmitted over a fieldbus system. The fieldbus master has to write the value on F0.21 (ASF command; Pressure command). For more detailed information, see Functional Description RE 62319-FK.

8.3.3 Pressure command learning

If the pressure command value is not known, an automatic learning algorithm can be activated. The activation can be made directly in the parameter F1.02 (Control word: Pressure command source).

Code	Name	Setting range	Default	Attri.
F1.08	Preferred swivel angle command source	0: Swivel angle command of F1.09 1: Communication	0	Stop
F1.09	Command value: Preferred swivel angle	0.00...100.00 %	70.00	Run
F3.12	Speed adaptation: P-gain	0.0...1,000.0 rpm/%	0.0	Run
F3.13	Speed adaptation: I-gain	0.0...1,000.0 rpm/%/s	50.0	Run
F3.16	Speed adaptation: D-gain	0.00...100.00 rpm/%*s	0.00	Run
F3.21	Speed adaptation: Ramp pitch, ascending	0...10,000 rpm/s	1,000	Run
F3.22	Speed adaptation: Ramp pitch, descending	-9,999...0 rpm/s	-800	Run

Tab. 8-8: Parameter list of speed adaption

Trigger level [F3.26]

A new learning procedure is started, if the difference between pressure feedback and recently learned command pressure exceeds the threshold defined in this parameter.

The recently learned pressure command value remains active until the new learning procedure has been completed.

Learning window [F3.27]

The pressure feedback value is monitored after a new learning procedure was started (cf. F3.26). For this purpose, the learning window defines a symmetrical pressure window around the current pressure feedback. If the pressure feedback remains within this learning window for the time defined in F3.28, the pressure is assessed to be stable and set as the new pressure command value.

Learning time [F3.28]

See description of learning window [F3.27].

The figure below visualizes the learning function parameterization.

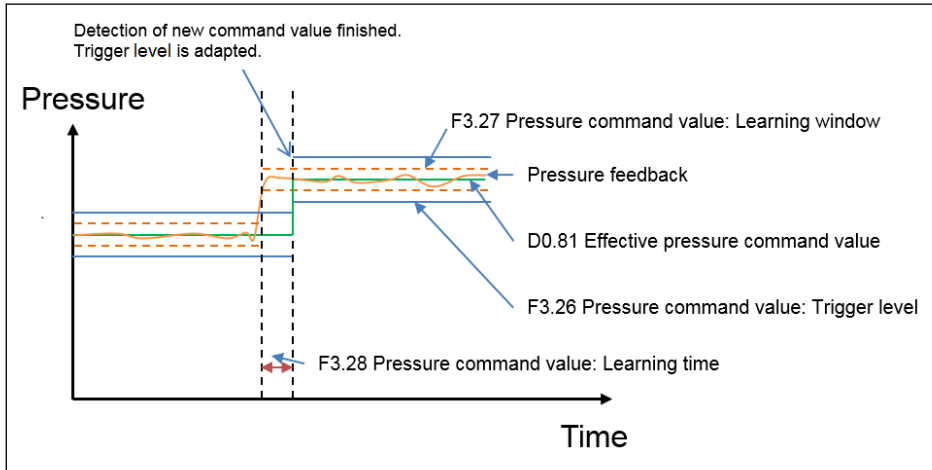

Fig. 8-1: Parameterization of pressure learning function

8.4 Speed adaption

8.4.1 General

When starting up is completed, speed adaption can be activated and deactivated during operation by "DRn variable speed enable" (X4 by default or ASF control word F0.20 from communication). With active speed adaption, the limit values for the minimum and maximum pump speed are valid.

If speed adaption gets deactivated, the drive speed is increased to maximum speed. The speed adaptation ramp pitch continues to be active (F3.21) during the acceleration phase.

The deactivation of speed adaption by "DRn variable speed enable" (X4 by default or ASF control word F0.20 from communication) can be used as an external trigger to increase the drive speed. This is useful in cases when the overriding control can foresee a subsequent increase of the hydraulic load to reduce the pressure drop. After the load change, speed adaption can be activated again. However, in most cases the automatic boost function will be suitable for most applications.

Speed adaption is at the core of the "Sytronix DRn" function and in operation at partial load allows the pump speed to be reduced in an intelligent way.

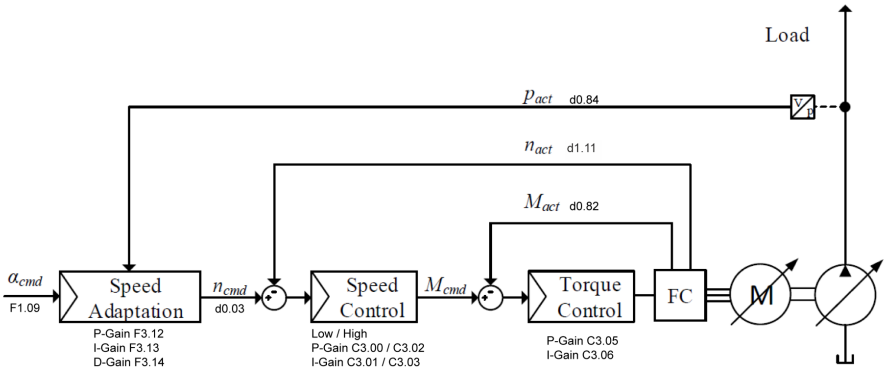

Fig. 8-2: Principle of DRn speed adaptation

8.4.2 Preferred swivel angle

The underlying principle consists of providing a preferred command value for the DR/DRG pump swivel angle. This swivel angle can be set in parameter F1.09. The selection of the preferred swivel angle source can be made directly in parameter F1.08.

Code	Name	Setting range	Default	Attri.
F1.08	Preferred swivel angle command source	0: Swivel angle command of F1.09 1: Communication	0	Stop
F1.09	Command value: Preferred swivel angle	0.00...100.00 %	70.00	Run

Tab. 8-9: Control word of pressure command source

The fixed value can be entered in F1.09 in the unit %.

100 % = Vg_max

0 % = Vg_min

If the setting "Master communication" is chosen the preferred swivel angle can be transferred via fieldbus communication on parameter F0.22 (ASF command 3; Preferred swivel angle command). For more detailed information, see Functional Description RE 62319-FK..

8.4.3 Controller settings

Code	Name	Setting range	Default	Attri.
F3.12	Speed adaptation: P-gain	0.0...1,000.0 rpm/%	0.0	Run
F3.13	Speed adaptation: I-gain	0.0...1,000.0 rpm/%/s	50.0	Run
F3.16	Speed adaptation: D-gain	0.00...100.00 rpm/%*s	0.00	Run

Code	Name	Setting range	Default	Attri.
F3.21	Speed adaptation: Ramp pitch, ascending	0...10,000 rpm/s	1,000	Run
F3.22	Speed adaptation: Ramp pitch, descending	-9,999...0 rpm/s	-800	Run

Tab. 8-10: Parameter list of speed adaption
Speed adaption has been designed as a PID-controller and can be configured with the following parameters.

K_P: Speed adaption: P-gain [F3.12]

This parameter sets the P-gain of the PID-controller implemented for speed adaption.

K_I: Speed adaption: I-gain [F3.13]

This parameter sets the I-gain of the PID-controller implemented for speed adaption.

K_D: Speed adaption: D-gain [F3.16]

This parameter sets the D-gain of the PID-controller implemented for speed adaption.

To avoid mutual influences between the hydromechanical DR/DRG controller on the pump and the speed adaption, it is recommended that only the integral part of the PID-controller be used. K_P and K_D should be left to 0 (default value).

Ascending speed ramp: [F3.21]

This parameter limits the positive gradient of speed adaption. For this purpose, the output of the PID-controller is monitored.

- If the ramp is too steep, this can cause instability in the superimposed pressure controller of the DR/DRG pump.
- A small ramp is not critical, but can cause the boost function to be activated.

Descending Speed Ramp: [F3.22]

This parameter limits the negative gradient of speed adaption. For this purpose, the output of the PID-controller is monitored.

- If the ramp is too steep, this can cause instability in the superimposed pressure controller of the DR/DRG pump.
- A small ramp is not critical, but decreases the effect of the speed adaption on the energy and noise reduction.

For more detailed information, see Functional Description RE 62319-FK.

9 Extended functions

9.1 Motor derating/fan monitoring

If a self-ventilated motor is used, the continuously available torque decreases when the drive speed is reduced. Below a certain motor speed the fan can no longer provide the required cooling power. Thus, the continuous torque has to

be delimited accordingly in the lower speed range. For this purpose, the "Sytronix DRn" function provides motor derating that automatically adjusts the speed adaption to the current load as required. The derating function is parameterized via the following parameters:

Code	Name	Setting range	Default	Attri.
C1.05	Motor rated power	See EFC documentation		
C1.09	Motor rated speed	See EFC documentation		
F4.55	Motor derating: Continuous torque at standstill	0.00...100.00 %	0.00	Stop
F4.56	Motor derating: Limit speed	0...10,000 rpm	0	Stop

Tab. 9-1: Parameter list of motor derating

C1.05 Motor rated power / C1.09 Motor rated speed

The motor derating uses the nominal motor torque as a reference value. It is internally calculated by means of C1.05 and C1.09:

$$Nominal\ torque\ [Nm] = \frac{Nominal\ power\ [kW]}{Nominal\ speed\ [rpm]} \cdot \frac{30}{\pi} \cdot 1000$$

F4.55 Motor derating: Continuous torque at standstill

The continuous torque at standstill of fan monitoring defines the torque that can be permanently held at speed zero. The input is in percent of the motor rated torque.

F4.56 Motor derating: Limit speed

The limit speed of the derating function defines the lower motor speed at which the nominal torque can be permanently maintained.

The figure below visualizes the parameterization of the motor derating.

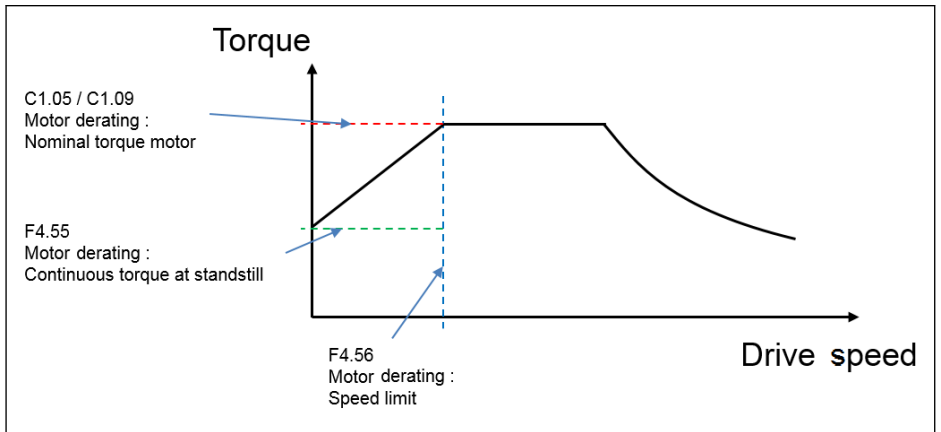

Fig. 9-1: Parameterization of motor derating

As soon as the drive speed has fallen below the parameterized speed limit value, the motor torque is monitored and it is made sure that the thermal limit characteristic from the figure above is not exceeded. Thermal overloading is avoided by increasing the motor speed.



Fan monitoring is deactivated as soon as one of the two parameters F4.55, F4.56 has the value "0".

9.2 Speed masking

The masking of a defined speed window can be parameterized to avoid resonance frequencies of the machine. The following parameters have to be configured.

Code	Name	Setting range	Default	Attri.
F4.57	Speed masking: Center speed	0...10,000 rpm	0	Run
F4.58	Speed masking: Window	0...10,000 rpm	0	Run

Tab. 9-2: Parameter list of speed masking

F4.57 Speed masking: Center speed

The center speed defines the center of the speed window to be masked to avoid resonance frequencies.

F4.58 Speed masking: Speed window

This parameter defines the width of the speed window to be masked to avoid resonance frequencies.

The figure below visualizes the parameterization of speed masking.

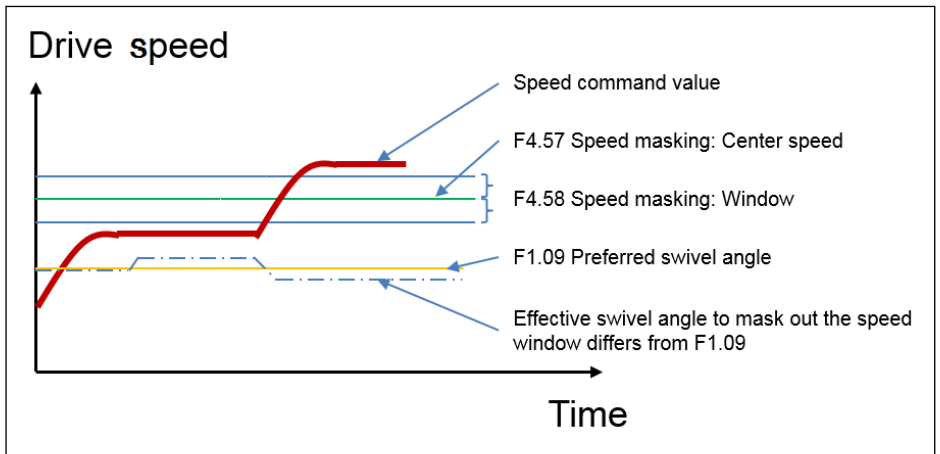

Fig. 9-2: Parameterization of speed masking

Speed masking still takes motor derating into account.



Speed masking is deactivated as soon as one of the two parameters F4.57, F4.58 has the value "0".

9.3 Motor stall monitoring

Under some heavy hydraulic load conditions, stalling of the induction motor can occur.

This function monitors the pressure as a function of time. If the pressure is under that threshold for longer than the time which is set, then either a large leakage or a motor stall has occurred.

Code	Name	Setting range	Default	Attri.
F4.00	Protection function control word	0...15 Bit0=0: Issues only a warning Bit0=1: Motor stall detection sets motor setpoint speed to zero on occurrence Bit3=0: Deactivate oil change detection Bit3=1: Activate oil change detection	0	Run
F4.61	Motor stall detection: Pressure threshold	0...10,000 bar	20	Run
F4.62	Motor stall detection: Wait time	0...10,000 ms	3,000	Run

Tab. 9-3: Parameter list of large leakage and motor stall detection

F4.61 Motor stall detection: Pressure threshold/F4.62 Motor stall detection: Wait time

The parameters describe a band between 0... [F4.61] bar. If the pressure actual value persists in this band longer than [F4.62] time, a motor stall or large leakage / load occurred and a reaction is triggered.

There are two reactions of this function, which is always on:

- F4.00 Bit0 = 0 -> reaction is only a warning
- F4.00 Bit0 = 1 -> reaction is a warning and speed command is set to zero to stop motor control

9.4 Sleep/wake-up function

This function is used to achieve the maximum extent of energy-saving according to the type of loads in actual applications, for example the hydraulic system with small leakage or accumulator. This function runs in parallel to the speed adaptation mode, while DRn 5020 ASF is active.

Code	Name	Setting range	Default	Attri.
E5.15	Sleep level	0.00...[E0.09] Hz	0.00	Run
E5.16	Sleep delay	0.0...3,600.0 s	60.0	Run
E5.19	Wake up level	0.0...100.0 %	0.0	Run
E5.20	Wake up delay	0.0...60.0 s	0.5	Run

Tab. 9-4: Parameter list of sleep / wake function

The pump controller may go into the sleep mode when all the conditions below are met:

- [Pressure feedback] \geq Pressure command value
- [Speed adaptation output] < [E5.15] "Sleep level"
- [Duration] $t \geq$ [E5.16] "Sleep delay"



- The wake-up level takes the unit of percentage. This percentage is referred to the pressure command value in bar.
- Speed adaptation output means the DRn algorithm speed set-point on the basis of which the system is controlled for an optimal operating point in terms of energy. This value has the same unit as sleep level, i.e. Hz.
- To check the actual motor frequency, monitor parameter d0.00.

9.5 Boost function

When speed adaption has been activated, the system pressure is continuously monitored. If the pressure value falls below a defined threshold (F3.24), the drive speed is accelerated to the maximum speed, regardless of the input from speed adaption. Speed adaption is continued as soon as the command pressure has been reached again. The following parameters have to be configured:

Code	Name	Setting range	Default	Attri.
F3.23	Speed boost: Ramp pitch	0...30,000 rpm/s	4,000	Run
F3.24	Speed boost: Pressure window	0.0...1,000.0 bar	10.0	Run
F3.25	Speed boost: Wait time	0...10,000 ms	0	Run

Tab. 9-5: Parameter list of boost function

F3.23 Speed boost: Ramp pitch

In the boost mode, the drive speed is accelerated to the maximum speed. This parameter is used to limit acceleration and avoid impacts on the mechanical pressure controller of the DR/DRG pump. As the boost function only takes effect when a pressure drop occurs, distinctly steeper ramps are possible than with active speed adaptation (cf. F3.21).

F3.24 Speed boost: Pressure window

The boost function is started as soon as the difference between pressure command value and actual pressure feedback exceeds this threshold value. The boost function remains deactivated until the pressure command value has been reached again.

F3.25 Speed boost: Wait time

A small pressure window in F3.24 can lead to a cyclic start of the boost function in case of a low-damped DR/DRG pressure controller. This parameter defines a minimum time between subsequent boost sequences to avoid the cyclic start.

The figure below visualizes the parameterization of the boost function.

9.6 Oil heater/cooler

9.6.1 General

It is possible to switch a cooler or a heater depending on the oil temperature. A digital output or a relay output can be used for switching a heater or a cooler on. For the settings for the output, see [chapter 7.6 "Digital and relay outputs" on page 19](#).

9.6.2 Digital oil temperature monitoring

An oil temperature sensor with digital outputs for warnings and/or errors is required and has to be connected to the digital input terminals. The required digital signals can be direct (24 V = warning/error) or inverse (0 V = warning/error).

The settings for the digital inputs are described in [chapter 7.5 "Digital inputs"](#) on page 18.

9.7 Oil level monitoring

The pump controller is able to monitor the oil level in a tank.

9.8 Swivel angle measurement

9.8.1 General

In some cases it is possible to equip the pump with a swivel angle sensor. The DRn 5020 ASF can evaluate the following sensor types:

- SWS20 voltage supply
- AWAX voltage supply
- AWAX current supply

The sensors cannot be freely configured. A swivel angle sensor may be used in case the swivel angle calculation is not exact enough. In addition, the use of a sensor allows the motor to be run in V/f mode. This makes sense, if no exact motor data are available for the motor or the dynamic motor auto-tuning function cannot be used.

If the swivel angle is to be calculated or measured can be configured in F4.80. As default observation/calculation is set.

Code	Name	Setting range	Default	Attri.
F4.80	Control word swivel angle	0 = swivel angle observer 1 = SWS20 (AI 0...5V) 2 = AWAX voltage sensor (AI 2...10 V) 3 = AWAX current sensor (AI 4...20 mA)	0 -	Run

Tab. 9-6: Swivel angle evaluation

9.8.2 Fine adjustment

In the condition as supplied the swivel angle sensor on the pump is not exactly adusted. To achieve the best performance it is recommended that the swivel angle sensor be adjusted. This should be made in two steps to set two parameters.

Step 1: Zero point

- Run the pump in pressure mode without any leakage and note the display parameter d0.85.
- Set F4.82 to the value you have noted.

Step 2: Factor

- Run the pump in flow mode with maximum swivel angle and note parameter d0.85 again.

$$F4.83 = \frac{100}{d0.85}$$

- Set F4.83 applying this formula:

Code	Name	Setting range	Default	Attri.
F4.82	Established zero point	-20.0...20.0	0.0	Stop
F4.83	Established factor	0.5...1.5	1.0	Stop

Tab. 9-7: Fine adjustment

9.9 Oil filter monitoring

Oil filter monitoring can be used to avoid complete clogging of an oil filter. The filter sensor issues digital signals which have to be connected to the digital input terminals of the pump controller.

Two different filters can be monitored. For every filter a pre-warning signal and a warning signal can be evaluated by the pump controller. The signals can also be direct or inverse.

The settings for the digital inputs are described in [chapter 7.5 "Digital inputs" on page 18](#). Oil filter monitoring is realized by means of a sensor, which takes pressure measurements inside the filter. When a pump starts up, an overpressure peak occurs in the filter. This would usually cause a filter warning to be issued, which can be avoided by setting a delay time in F4.76.

Code	Name	Setting range	Default	Attri.
F4.76	Oil filter pre-warning / warning 100% delay time	0...3,600 s	60	Run

Tab. 9-8: Oil filter warning

A pre-warning or a warning situation is displayed in the warning status word d0.87.

9.10 LED flash indicating converter status

The pump controller status can be shown with a multi-color LED strap. Two digital outputs are needed to set a green and a red LED input. Both signals give a yellow light. The settings for these outputs are described in [chapter 7.6 "Digital and relay outputs" on page 19](#).

For normal status the light is always green, for warning condition the light will flash green and yellow, and for error condition flash red and yellow. The flash time of the yellow light represents the warning / error type. More details are shown on the following figure.

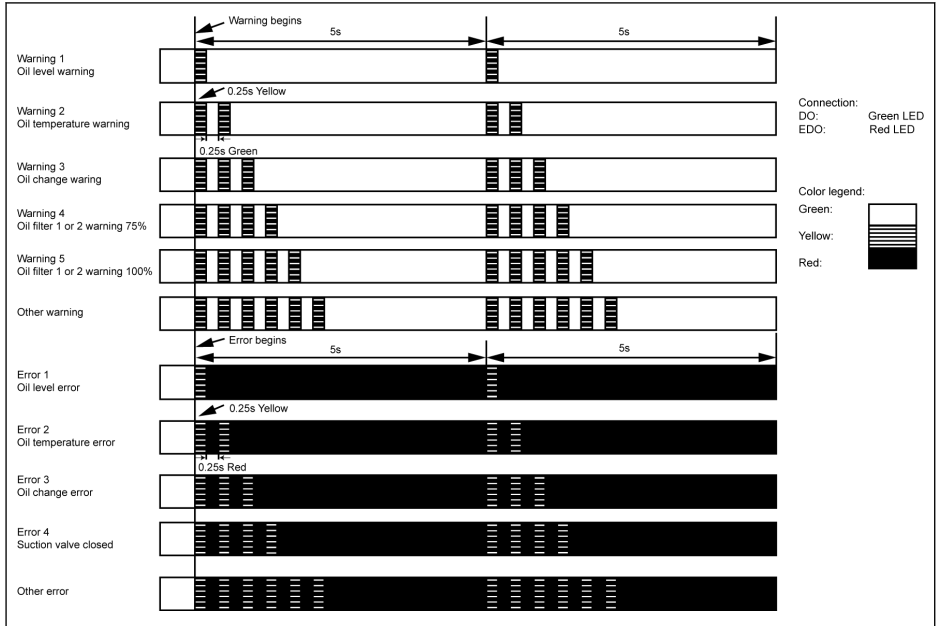

Fig. 9-3: LED flash function

9.11 Oil change warning/error function

Code	Name	Setting range	Default	Attri.
F4.00	Protection function control word	0...15 Bit0=0: Issues only a warning Bit0=1: Motor stall detection sets motor setpoint speed to zero on occurrence Bit3=0: Deactivate oil change detection Bit3=1: Activate oil change detection	0	Run
F4.63	Warning hours of oil change	0...60,000 hours	36,000	Run
F4.64	Error hours of oil change	0...60,000 hours	40,000	Run
F4.65	Oil in operation time hour	-	-	Read
F4.66	Reset oil in operation time	0...1	0	Run

Tab. 9-9: Parameter list of oil change warning / error function

Once the oil change monitoring function has been activated (F4.00 bit3), the oil operation time will be counted and saved in [F4.65]. If this time exceeds warning or error level in [F4.63] or [F4.64], a warning or error signal will be generated. Parameter F4.66 = '1' is used to reset the oil operation timer F4.65.

The oil change warning / error is related to warning d0.87 bit9 and error d0.89 bit14.

10 Fieldbus communication

10.1 Brief introduction

The DRn 5020 controller provides the possibility of communicating with a higher-level PLC over various field bus systems. Via this communication the controller can receive control words and command values. Vice versa, the controller can transmit status words and actual values. The controller can be equipped with various optional communication cards.

Two optional cards are available:

- A PROFIBUS option for:
 - PROFIBUS DP
- A Multi-Ethernet card for the Ethernet-based field bus systems:
 - PROFINET I/O
 - EtherCAT CoE
 - EtherNet/IP
 - Sercos



- Cycle time for command and status value exchanging is 2 ms.
- Bus communication and internal ASF data communication are not synchronized.

10.2 Command values MDT

Command values are written on the parameters F0.20.....F0.23.

Code	Name	Description	Setting range
F0.20	ASF command 1	ASF control word	0...65,535
F0.21	ASF command 2	Pressure command	50...10,000 (5.0...1,000.0 bar)
F0.22	ASF command 3	Preferred swivel angle command	0...10,000 (0.00...100.00 %)
F0.23	ASF command 4	Maximum flow/speed limit	0...10,000 rpm

Tab. 10-1: Communication protocol

The ASF control word has the following bit assignment.

Bit	Description	Setting range
0	DRn enable (X3)	0: Inactive 1: Active
1	DRn variable speed enable (X4)	0: Inactive 1: Active
2...14	Reserved	-
15	ASF control word enable	0: Inactive 1: Active

Tab. 10-2: ASF control word definition



To activate the ASF control word it is recommended that bit 15 is kept permanently enabled. For more information about field bus communication, see Functional Description RE 62319-FK.

11 DRn 5020 parameter list

11.1 Terminology and abbreviations in parameter list

- **Code:** Function / parameter code, written in Cx.xx, Dx.xx, Ex.xx, Fx.xx
- **Name:** Parameter name
- **Default:** Factory default
- **Attri.:** Parameter attribute
 - **Run:** Parameter setting can be modified when the converter is in run or stop status.
 - **Stop:** Parameter setting can only be modified when the converter is in stop status.
 - **Read:** Parameter setting is read-only and cannot be modified.
- **[Cx.xx], [Dx.xx], [Ex.xx], [Fx.xx]:** Function / parameter values

11.2 Group F1: Quick start parameters

Code	Name	Setting range	Default	Attri.
F1.00	ASF parameter initialization	0: Inactive 1: Restore to ASF default settings 2: Deactivate ASF	0	Stop
F1.02	Control word: Pressure command source	0: Depend on the value of F1.04 1: Communication 2: Analog input 3: Learning pressure command 4: Select by digital input (F1.04 shows status)	0	Stop
F1.04	Pressure command selection	0: Pressure command digital setting 0 1: Pressure command digital setting 1	0	Run
F1.05	Pressure command digital setting 0	5.0...1,000.0 bar	5.0	Run
F1.06	Pressure command digital setting 1	5.0...1,000.0 bar	5.0	Run
F1.08	Preferred swivel angle command source	0: Swivel angle command of F1.09 1: Communication	0	Stop
F1.09	Command value: Preferred swivel angle	0.00...100.00 %	70.00	Run
F1.15	Motor type	0: Others 1: MOT-EC__-HOY	0	Stop
F1.16	Motor power level	0: No selection 1...24 (only change motor parameter by switching from 0 to 1...24)	0	Stop

Tab. 11-1: Parameter list of group F1

11.3 Group F2: Input and output parameters

Code	Name	Setting range	Default	Attri.
F2.00	Analog input AI1	0: No function assigned	0	Stop
F2.01	Analog input AI2	1: Pressure command	2	Stop
F2.02	Extended analog input EAI	2: Pressure feedback	0	Stop
F2.03	External analog input EAI2	5: Maximum flow/speed limit 6: Swivel angle feedback	0	Stop
F2.04	Pressure command corresponding to 10 V / 20 mA	0.1...1,000.0 bar	100.0	Stop
F2.05	Pressure command null offset in V or mA	0...5.0 V, mA	0.1	Stop
F2.06	Pressure feedback corresponding to 10 V or 20 mA	0.1...1,000.0 bar	100.0	Stop
F2.07	Pressure feedback null offset in V or mA	0.0...5.0 V, mA	0.1	Stop
F2.08	Flow command corresponding to 10V or 20mA	1...10,000 rpm	400	Stop
F2.09	Flow command null offset in V or mA	0.0...5.0 V, mA	0.0	Stop

Code	Name	Setting range	Default	Attri.
F2.10	Pressure sensor type	0: Others 1: HM20-2X/10-C 2: HM20-2X/50-C 3: HM20-2X/100-C 4: HM20-2X/160-C 5: HM20-2X/250-C 6: HM20-2X/315-C 7: HM20-2X/400-C 8: HM20-2X/630-C 9: Other 4...20 mA pressure sensor 10: Reserved 11: HM20-2X/10-H 12: HM20-2X/50-H 13: HM20-2X/100-H 14: HM20-2X/160-H 15: HM20-2X/250-H 16: HM20-2X/315-H 17: HM20-2X/400-H 18: HM20-2X/630-H 19: Other 0.1...10V pressure sensor	3	Stop
F2.13	Maximum flow/speed limit selection	0: Maximum flow/speed digital setting 0 1: Maximum flow/speed digital setting 1	0	Run
F2.14	Maximum flow limit source	0: Depend on the value of F2.13 1: Communication 2: Analog input 3: Select by digital input (F2.13 shows status)	0	Stop

Code	Name	Setting range	Default	Attri.
F2.15	DRn command source	Bit0: Switch DRn function source ● 0: Digital input ● 1: Communication Bit1: Switch speed adaption source ● 0: Digital input ● 1: Communication Bit 2: Activate DRn with RUN command Bit 3: Activate speed adaption with RUN command	0	Stop
F2.16	X1 input	0: No function assigned by ASF 1: Pressure command selection bit0	0 (Enable)	Stop
F2.17	X2 input	2...3: No function 4: Flow limitation selection	0 (Error Reset)	Stop
F2.18	X3 input	5...9: No function	10	Stop
F2.19	X4 input	10: Activate DRn function	11	Stop
F2.20	X5 input	11: Activate speed adaption	0	Stop
F2.21	EX1 input	13: Oil level warning	0	Stop
F2.22	EX2 input	14: Oil temperature warning	0	Stop
F2.23	EX3 input	15: Oil filter 1 pre-warning	0	Stop
F2.24	EX4 input	16: Oil filter 1 warning 100% 17: Oil filter 2 pre-warning 18: Oil filter 2 warning 100% 19: Oil level error 20: Oil temperature error 21: Suction valve closed error 22: Oil level warning inverse 23: Oil temperature warning inverse 24: Oil filter 1 pre-warning inverse 25: Oil filter 1 warning 100% inverse 26: Oil filter 2 pre-warning inverse 27: Oil filter 2 warning 100% inverse 28: Oil level error inverse 29: Oil temperature error inverse 30: Suction valve closed error inverse	0	Stop

Code	Name	Setting range	Default	Attri.
F2.36	DO1 output	0: No function assigned by ASF	1	Run
F2.37	EDO output	1: Converter warning	0	Run
F2.38	EDO2 output	2: Green flashing LED	0	Run
F2.40	Relay 1 output	3: Red flashing LED	0	Run
F2.41	Extension relay output	4: Cooler on 5: Heater on	0	Run

Tab. 11-2: Parameter list of group F2

11.4 Group F3: Controller parameters

Code	Name	Setting range	Default	Attri.
F3.12	Speed adaptation: P-gain	0.0...1,000.0 rpm/%	0.0	Run
F3.13	Speed adaptation: I-gain	0.0...1,000.0 rpm%/s	50.0	Run
F3.16	Speed adaptation: D-gain	0.00...100.00 rpm/%*s	0.00	Run
F3.19	Speed adaptation: Minimum speed	0...10,000 rpm	300	Run
F3.20	Speed adaptation: Maximum speed 0	0...10,000 rpm	1,000	Run
F3.21	Speed adaptation: Ramp pitch, ascending	0...10,000 rpm/s	1,000	Run
F3.22	Speed adaptation: Ramp pitch, descending	-9,999...0 rpm/s	-800	Run
F3.23	Speed boost: Ramp pitch	0...30,000 rpm/s	4,000	Run
F3.24	Speed boost: Pressure window	0.0...1,000.0 bar	10.0	Run
F3.25	Speed boost: Wait time	0...10,000 ms	0	Run
F3.26	Pressure command value: Trigger level	0.0...1,000.0 bar	5.0	Run
F3.27	Pressure command value: Learning window	0.0...1,000.0 bar	3.0	Run
F3.28	Pressure command value: Learning time	0...10,000 ms	1,000	Run
F3.29	Start-up time	0...30,000 ms	2,000	Run
F3.30	Speed adaptation: Maximum speed 1	0...10,000 rpm	1,000	Run

Tab. 11-3: Parameter list of group F3

11.5 Group F4: Motor and pump settings

Code	Name	Setting range	Default	Attri.
F4.00	Protection function control word	0...15 Bit0=0: Issues only a warning Bit0=1: Motor stall detection sets motor setpoint speed to zero on occurrence Bit3=0: Deactivate oil change detection Bit3=1: Activate oil change detection	0	Run
F4.29	Pump type	0...31	1	Stop
F4.30	Pump: Maximum displacement	1.0...5,000.0 ccm	18.0	Stop
F4.47	Maximum torque limitation	200.0...400.0 %	200.0	Stop
F4.50	Pump: Maximum angular acceleration	0...60,000 rad/s ²	1,500	Stop
F4.51	Pump: Maximum speed	0...10,000 rpm	1,000	Stop
F4.52	Pump: Minimum speed	0...10,000 rpm	300	Stop
F4.53	Pump: Inertia mantissa	0...10,000 kgm ²	100	Stop
F4.54	Pump: Inertia exponent	0...10	5	Stop
F4.55	Motor derating: Continuous torque at standstill	0.00...100.00 %	0.00	Stop
F4.56	Motor derating: Limit speed	0...10,000 rpm	0	Stop
F4.57	Speed masking: Center speed	0...10,000 rpm	0	Run
F4.58	Speed masking: Window	0...10,000 rpm	0	Run
F4.59	Auxiliary pump: Displacement	0.0...5,000.0 ccm	0.0	Stop
F4.60	Auxiliary pump: Pressure	0.00...250.00 bar	0.00	Stop
F4.61	Motor stall detection: Pressure threshold	0...10,000 bar	20	Run
F4.62	Motor stall detection: Wait time	0...10,000 ms	3,000	Run
F4.63	Warning hours of oil change	0...60,000 hours	36,000	Run
F4.64	Error hours of oil change	0...60,000 hours	40,000	Run
F4.65	Oil in operation time hour	-	-	Read
F4.66	Reset oil in operation time	0...1	0	Run
F4.76	Oil filter pre-warning / warning 100% delay time	0...3,600 s	60	Run

Code	Name	Setting range	Default	Attri.
F4.80	Control word swivel angle	0 = Swivel angle observer 1 = SWS20 (AI 0 - 5 V) 2 = AWAX voltage sensor (AI 2 - 10 V) 3 = AWAX current sensor (AI 4 - 20 mA)	0	Stop
F4.82	Established zero point	-20.0...20.0	0.0	Stop
F4.83	Established factor	0.5...1.5	1.0	Stop

Tab. 11-4: Parameter list of group F4

11.6 Important EFC parameters

Code	Name
b0.00	Access authority setting
C1.05	Motor rated power
C1.09	Motor rated speed
C1.13	Motor inertia mantissa
C1.14	Motor inertia exponent
C3.43	Torque reference maximum value
C3.44	Torque positive limit
E0.26	Acceleration time
E0.27	Deceleration time
E1.60	Motor temperature sensor channel
E1.61	Broken wire protection

Tab. 11-5: Parameter list of used EFC parameters

11.7 Auto-modified EFC parameters in ASF initialization

Code	Name	Setting range	Default	Attri.
C0.00	Control mode (EFC 5610 only)	0: V/f control 1: Sensorless vector control	1	Stop
C1.69	Motor thermal model protection setting	0: Inactive 1: Active	1	Stop
E0.01	First run command source	0...2	1	Stop
E0.02	Second frequency setting source	0...99	0	Stop
E0.08	Maximum output frequency	50.00...400.00 Hz	100.00	Stop
E0.09	Output frequency high limit	[E0.10]...[E0.08] Hz	100.00	Run
E0.17	Direction control	0: Forward / Reverse 1: Forward only 2: Reverse only 3: Swap default direction	3	Stop
E0.26	Acceleration time	0.1...6,000.0 s	0.1	Run
E0.27	Deceleration time	0.1...6,000.0 s	0.1	Run
E0.35	Start mode	0: Start directly 1: DC-braking before start 2: Start with speed tracing 3: Automatic start/stop according to setting frequency	1	Stop
E0.39	Start DC-braking current	0.0 ... 150.0 %	50.0 %	Stop
E1.00	X1 input	0...46	35	Stop
E1.01	X2 input	0...46	34	Stop
E1.40	AI2 input mode	0: 0...20 mA 1: 4...20 mA 2: 0...10 V 3: 0...5 V 4: 2...10 V	2	Run
E1.60	Motor temperature sensor channel	0: Inactive 1: AI1 analog input 2: AI2 analog input 3: EAI analog input	0	Stop
E2.15	Relay1 output selection	0...99	14	Stop

Code	Name	Setting range	Default	Attri.
E2.25	AO1 output mode	0: 0...10 V 1: 0...20 mA	1	Run
E2.26	AO1 output setting	0: Output frequency 1: Setting frequency 2: Output current 4: Output voltage 5: Output power 6: AI1 analog input 7: AI2 analog input 8: EAI analog input 11: Motor temperature sensor power supply 99: Inactive	0	Run

Tab. 11-6: Auto-modified EFC parameter list

12 Diagnosis

12.1 Warnings

Warnings of the DRn function are displayed in the parameters D0.86 and D0.87 according to the following tables. When a warning occurs, the display shows "APF1" in every case. The value in the "Code" column can be examined from D0.86 and D0.87 to find out which warning occurred.

Bit	Code	Condition	Description
0	1	F3.23 < F3.21	Speed boost ramp pitch is smaller than speed adaptation ramp pitch (ascending)
1	2	F3.21 = 0	Speed adaptation ramp pitch (ascending) 0 impedes speed adaptation
2	4	F3.22 = 0	Speed adaptation ramp pitch (descending) 0 impedes speed adaptation
3	8	F3.23 = 0	Speed boost ramp pitch 0 impedes boost function
4	16	F3.24 = 0	Speed boost pressure window 0 causes permanently active boost function
5	32	F3.24 < 1	Narrow speed boost pressure window can cause boost function to cyclically start
6	64	F3.21 > F4.50	Speed adaptation ramp pitch (ascending) exceeds maximum pump angular acceleration
7	128	F3.22 > F4.50	Speed adaptation ramp pitch (descending) exceeds maximum pump angular acceleration

Bit	Code	Condition	Description
8	256	$F3.23 > F4.50$	Speed boost ramp pitch exceeds maximum pump angular acceleration
9, 10	Reserve		
11	2048	$F3.19 < F4.52$	Speed adaptation minimum speed is lower than minimum pump speed
12	4096	$F3.20 > F4.51$	Speed adaptation maximum speed exceeds maximum pump speed
13	8192	$F3.19 \geq F3.20$	Speed adaptation minimum speed is greater than or equal to speed adaptation maximum speed
14	Reserve		
15	32768	$F4.57 - F4.58 < F3.19$	Masked speed window drops bellow speed adaptation minimum speed

Tab. 12-1: Warnings in D0.86

Bit	Code	Condition	Description
0	1	$F4.57 + F4.58 > F3.20$	Masked speed window exceeds speed adaptation maximum speed
1...3	Reserve		
4	16	$F4.53 = 0$	No pump inertia is parameterized
5	32	$F4.55 > 100$	Motor derating-continuous torque at standstill exceeds motor nominal torque
6	64	Oil level warning	Oil level is too low. Refill oil
7	128	Oil temperature warning	Oil temperature reached. Reduce hydraulic losses or enhance oil cooling
8	256	Motor stall	Motor is stalled or large leakage in the system
9	512	Oil change warning	Operation time exceeds oil life time. Change oil and reset operation timer (F4.54)
10	1024	$F3.29 = 0$	No start-up time parameterized. Default value of 2,000 ms is active
11	2048	Pump type invalid	Chosen pump type is not available or manual configuration of pump data is invalid (F4.30, F4.50...F4.54)
12	4096	Oil filter 1 pre-warning	Oil filter almost clogged. Clean or replace filter
13	8192	Oil filter 1 warning 100%	Oil filter clogged 100%. Clean or replace filter
14	16384	Oil filter 2 pre-warning	Oil filter almost clogged. Clean or replace filter
15	32768	Oil filter 2 warning 100%	Oil filter clogged 100%. Clean or replace filter

Tab. 12-2: Warnings in D0.87

If different warnings are generated simultaneously, the values of D0.86 or D0.87 are combined and different warning codes from the table show up. For example, Bit0 and Bit1 of D0.86 are combined, the diagnostic code will be $1 \text{ (Bit0)} + 2 \text{ (Bit1)} = 3$.

12.2 Error codes

Errors of the DRn function are displayed in the parameters D0.88 and D0.89 according to the following tables. When an error occurs, the display shows "APE1" in every case. The value in the "Code" column can be examined from D0.88 and D0.89 to find out which error occurred.

Bit	Code	Condition	Description
0...5	Reserve		
6	64	F3.21 > F4.50	Speed adaptation ramp pitch (ascending) exceeds maximum pump angular acceleration
7	128	F3.22 > F4.50	Speed adaptation ramp pitch (descending) exceeds maximum pump angular acceleration
8	256	F3.23 > F4.50	Speed boost ramp pitch exceeds maximum pump angular acceleration
9, 10	Reserve		
11	2048	F3.19 < F4.52	Speed adaptation minimum speed is lower than minimum pump speed
12	4096	F3.20 > F4.51	Speed adaptation maximum speed exceeds maximum pump speed
13	8192	F3.19 > F3.20	Speed adaptation minimum speed is higher than speed adaptation maximum speed

Tab. 12-3: Errors in D0.88

Bit	Code	Condition	Description
0	Reserve		
1	2	Parameter setting fault	Parameter setting repetition. Check if parameter settings are in conflict
2...4	Reserve		
5	32	F4.55 > 100	Motor derating-continuous torque at standstill exceeds motor nominal torque
6...10	Reserve		
11	2048	Pump type invalid	Chosen pump type is not available or manual configuration of pump data is invalid (F4.30, F4.50...F4.54)
12	4096	Oil level error	Oil level too low. Refill oil
13	8192	Oil temperature error	Oil temperature reached. Reduce hydraulic losses or enhance oil cooling
14	16384	Oil change error	Operation time exceeds oil lifetime. Change oil and reset operation timer F4.54
15	32768	Suction valve closed	Open the valve at suction line

Tab. 12-4: Errors in D0.89

If different errors are queued, the value of D0.88 or D0.89 is superimposed and various error codes from the table show up. For example, Bit0 and Bit1 of D0.86 are queued, diagnostic code will be $64 \text{ (Bit6)} + 128 \text{ (Bit7)} = 192$.

12.3 Monitoring parameters

Code	Description	Unit
H0.01	Status word standard firmware	-
H0.02	Extended status word	-
d0.00	Actual frequency	Hz
d0.01	Actual speed	rpm
d0.03	Speed command value	rpm
d0.80	DRn status word	-
d0.81	Effective pressure command value	bar
d0.82	Torque actual value	Nm
d0.83	Effective swivel angle command value	%
d0.84	Pressure feedback	bar
d0.85	Pump: Actual swivel angle	%
d0.86	ASF Display06, Warnings (word)	-
d0.87	ASF Display07, Warnings (word)	-
d0.88	ASF Display08, Errors (word)	-
d0.89	ASF Display09, Errors (word)	-
d0.98	Motor current	A
d1.11	Rotor speed	rpm

Tab. 12-5: Monitoring parameter

For detailed information about parameter D0.80, please refer to the following table.

Bit	Description
0	DRn active
1	Speed adaption active
2	Warning active
3	Error active
4	p_cmd reached
5	Max speed reached
6	Min speed reached
7	Boost active
8	Ramp limiter active
9	Learn p_cmd enabled
10	Learn p_cmd active
11	Speed masking active
12	Fan monitoring active

Bit	Description
13	Start-up active
14	ConstSpeed active

Tab. 12-6: Bit definition of D0.80

For information about standard firmware status word, please see EFC5610 Operating Instructions R912005854.

Index

A

Abbreviations.....	4
Analog inputs.....	15
Analog output AO1.....	17
Auto-modified EFC parameters in ASF initialization.....	51
Auxiliary pump.....	20

B

Boost function.....	38
---------------------	----

C

Command values MDT.....	42
Configuration of pressure sensor.....	24
Controller parameters.....	48
Controller settings.....	31

D

Diagnosis.....	52
Digital and relay outputs.....	19
Digital inputs.....	18
Documentation reference.....	6
DRn 5020 parameter list.....	43

E

EFC 5610 parameters.....	51
Error codes.....	55
Extended functions.....	32

F

Fieldbus communication.....	42
Function specification.....	7

G

Getting started quickly.....	9
Group F1 Parameters.....	44
Group F2 Parameters.....	45
Group F3 Parameters.....	48
Group F4 Parameters.....	49

I

Important EFC parameters.....	50
Input and output parameters.....	45

IO configuration and settings.....	13
------------------------------------	----

L

LED flash indicating converter status.....	40
Loading pump parameters.....	19

M

Main functions.....	25
Maximum speed limitation.....	25, 27
Monitoring parameters.....	57
Motor and pump settings.....	49
Motor derating/fan monitoring.....	32
Motor parameters.....	21
Motor stall monitoring.....	36

O

Oil change warning/error function.....	41
Oil filter monitoring.....	40
Oil heater/cooler.....	38
Oil level monitoring.....	39
Overview and electrical connection.....	13

P

Parameter list.....	43
Preconfigured motor parameters.....	21
Preferred swivel angle.....	31
Pressure command learning.....	29
Pressure command value.....	27
Pressure command value sources.....	27

Q

Quick start parameters.....	44
-----------------------------	----

R

Restoring ASF parameters.....	14
-------------------------------	----

S

Scope of supply.....	5
Sleep/wake up function.....	37

Speed adaption.....	30
Speed masking.....	35
Start-up sequence.....	12
Swivel angle measurement.....	39

T

Terminology and abbrevia- tions in parameter list.....	43
Type code.....	1

W

Warnings.....	52
---------------	----

Notes

Bosch Rexroth AG
Industrial Hydraulics
Zum Eisengießer 1
97816 Lohr a.Main, Germany
Phone +49 9352 403020
my.support@boschrexroth.de
www.boschrexroth.com



R912007127