

Press module for hydraulic presses

Type IH04C

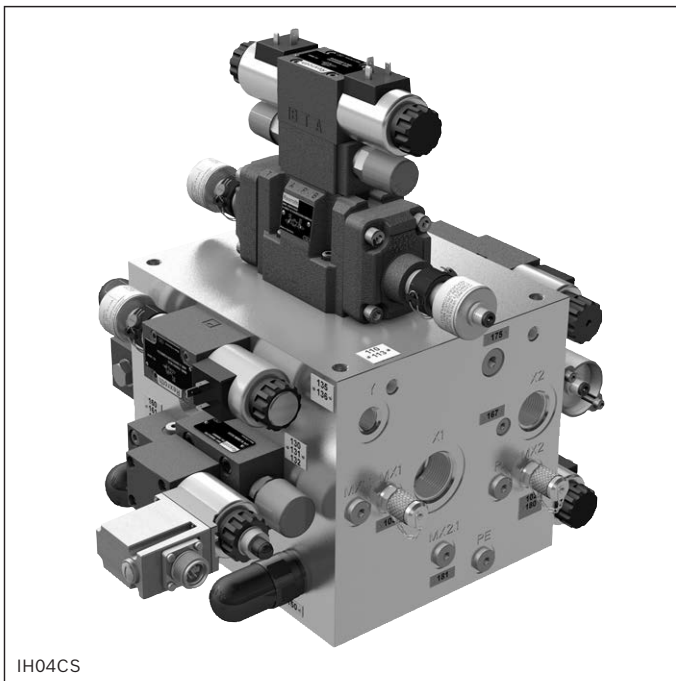

- ▶ Size 10, 16, 25, 32, 35
- ▶ Component series 7X
- ▶ Maximum operating pressure 350 bar
- ▶ Maximum flow 2,000 l/min
- ▶ Hydraulic control for downstroke piston

Contents

Features, contents	1
Ordering code	2, 3
Function	4, 5
Technical data	6, 7
Characteristic curves	8, 9
Basic functions according to safety category 4	10 ... 12
Rapid traverse due to own weight with prefill valve	13, 14
Rapid traverse with rapid traverse cylinder	15, 16
Rapid traverse with differential circuit	17, 18
Operation with high- and low-pressure pumps	19, 20
Load-sensing	21 ... 23
High-response valve with zero overlap	24 ... 26
Pressure holding on the piston chamber side	27, 28
Accumulator operation	29, 30
Slide cushion	31, 32
Set-up by own weight with prefill valve	33 ... 35
Basic functions according to safety category 1	36, 37
Safe reduced velocity < 10 mm/s	38, 39
Safe reduced velocity < 10 mm/s and testing of the braking force of the restraint device	40, 41
General information	42
Recommended pump versions	43, 44
Further information	44

Features

- ▶ Hydraulic control for machine types according to ISO 16092-3 and EN 289
- ▶ EC type examination certificate HSM15009
- ▶ The base module 100 includes all safety-related functions according to category 4 of DIN EN ISO 13849-1.
- ▶ The extension modules 200 include all common circuits for hydraulic presses.
- ▶ Suitable for
 - pressure/position controls
 - open circuit
- ▶ Modular design
- ▶ Supply connections on the side and at the bottom
- ▶ Thick film passivated (free from chromium(VI))

Ordering code

01	02	03	04	05	06	07	08	09	10	11	12	13	14
IH04	C	-	7X	/									

Machine function

01	Downstroke piston	C
----	-------------------	----------

Safety category

02	According to ISO 13849, category 4, with type-examination certificate	S
	According to ISO 13849, category 1	N

Component series

03	Component series 70 ... 79 (unchanged installation and connection dimensions)	7X
----	---	-----------

Size

04	10, 16, 25, 32, 35	10 ... 35
----	--------------------	------------------

Operating pressure

05	315 bar	G
	350 bar	S

Number of mounted modules (version-dependent)

06	Base module 100	1
	Base module 100 with one extension module 200	2
	Base module 100 with two extension modules 200	3

Pump pressure limitation – Item 120

07	With manual pressure adjustment ¹⁾	B
	With proportional pressure adjustment	E
	With manual pressure adjustment and depressurized circulation	W

Press force adjustment in the piston chamber – Item 130

08	With manual pressure adjustment	B
	With proportional pressure adjustment	E
	With manual pressure adjustment and piston chamber preloading	U

Load holding – Item 160

09	In the T channel of item 110 and with manual pressure adjustment	0
	In the T channel of item 110 and with manual pressure adjustment and switchable rapid traverse by own weight with prefill valve	1
	In the B channel of item 110 and with manual pressure adjustment ²⁾	2
	In the B channel of item 110 and with manual pressure adjustment and switchable rapid traverse by own weight with prefill valve ²⁾	3

Safe reduced velocity (< 10 mm/s) according to ISO 16092-3, section 5.3.2.16 - Item 170

10	Without	N
	Safe reduced velocity	D
	Safe reduced velocity and testing of the restraint device	P

¹⁾ With load-sensing

²⁾ Upon request. Suitable for powder presses, synchronization control, set-up with two-hand operation, closing velocities below 10% of the maximum closing velocity, presses with small annulus areas.

Ordering code

	01	02	03	04	05	06	07	08	09	10	11	12	13	14
IH04	C		-	7X	/						-	-	-	-

Directional valve – Item 110

11	5-4WE10E7X/EG24K4QS0G24W/M	IH04C-7X/10	WE-000E
	H-4WEH10E4X/6EG24SK4QM0G24		WEH000E
	4WREEM10E75-2X/G24K34/B6V ¹⁾		EEM075E
	4WREE10V75-2X/G24K31/A1V ¹⁾		REE075V
H-4WEH16E7X/6EG24SK4QM0G24	4WRTEM16E220L-4X/6EG24K31/A1M	IH04C-7X/16	WEH000E
	4WRDE16V220L-6X/MXY/24A1		TEM220E
			RDE220V
H-4WEH25E6X/6EG24SK4QM0G24	4WRTEM25E350L-4X/6EG24K31/A1M	IH04C-7X/25	WEH000E
	4WRDE25V350L-6X/MXY/24A1		TEM350E
			RDE350V
H-4WEH32E6X/6EG24SK4QM0G24	4WRTEM32E600L-4X/6EG24K31/A1M	IH04C-7X/32	WEH000E
	4WRDE32V600L-5X/6L24K9/MR		TEM600E
			RDE600V
4WRTEM35E1300L-4X/6EG24K31/A1M	4WRDE35V1000L-5X/6L24K9/MR	IH04C-7X/35	TEM1K3E
			RDE1K0V
Other valves upon request			

Extension modules – Item 200

12	None	NN
	With rapid traverse cylinder	EN
	With rapid traverse cylinder and load-sensing	EL
	With rapid traverse cylinder and high-response valve with zero overlap	ER
	With rapid traverse cylinder and pressure holding on the piston chamber side	EX
	With rapid traverse cylinder and accumulator operation	ES
	With differential circuit ²⁾	DN
	With differential circuit and pressure holding on the piston chamber side ²⁾	DX
	With high-pressure and low-pressure pumps	HN
	With high-pressure and low-pressure pumps and pressure holding on the piston chamber side	HX
	With load-sensing	LN
	With load-sensing and pressure holding on the piston chamber side	LX
	With high-response valve with zero overlap	RN
	With high-response valve with zero overlap and pressure holding on the piston chamber side	RX
	With pressure holding on the piston chamber side	XN
	With pressure holding on the piston chamber side and accumulator operation	XS
	With accumulator operation	SN
	With slide cushion	ZN

Voltage

13	DC voltage 24V	G24
----	----------------	------------

Additional version

14	Directional valve item 110 with asymmetric spool P→A: q _v ; P→B: q _v /2	001
	Set-up by own weight (> 10 mm/s)	002

¹⁾ Up to 315 bar only, otherwise on request

²⁾ Up to NG 25 only

Function

The press module type C is a hydraulic control for the installation in hydraulic presses according to EN ISO 16092-3 or plastic and rubber machines according to DIN EN 289 and is - according to DIN EN ISO 13849-1 - regarded as "safety-related part of control systems". The industrial area of application is extended to all machine types which require the safety requirements of the above-specified standards.

The press module type C allows the user to design, construct, and/or modify their downstroke piston functions such as press slide, blank pressure pad and slide cushion according to the general safety requirements. In connection with a suitable electric control, category 4, PLe according to DIN EN ISO 13849-1 can be reached for the following safety measures:

Safety measures for the hazard type	Extract from standard	Performance level (PL)	Safety category
Avoiding the unintended lowering under own weight	ISO 16092-3 section 5.3.7.2	e	4
Avoiding the unintended start-up from the rest position	ISO 16092-1 section 5.4.1.1.4a)	e	4
Stopping of the dangerous closing movement	ISO 16092-1 section 5.4.1.1.4c)	e	4
Safe reduced velocity below 10 mm/s with hold-to-run device	ISO 16092-3 section 5.3.2	d	3

The EC type examination certificate HSM15009 has been granted. The tested type complies with the relevant provisions of Directive 2006/42/EC (Machinery). Additionally to ISO 16092-3, section 5.3.7.3, unintended lowering under own weight during the retraction of the

hydraulic upholding equipment item 140 is safely prevented. During muting, errors can be recognized in time by analysis of the end-switch signal S14.

Base module 100

A complete press module type C consists at least of the base module item 100 and the directional valve item 110. The safety-related functions (cat. 1 or 4) are part of the basic design and do not influence the attachment of the additional extension modules item 200¹⁾.

The pump and tank connections are arranged on the side and at the bottom and allow for perfect installation into the press. All other actuator ports are arranged on the side²⁾. All measuring points are provided with two connections.

Safety-related hydraulic control according to category 4 of ISO 13849	Directional valve with position monitoring (channel 1)	Item 110
	Pump pressure limitation	Items 120 ... 122
	Protection against unwanted pressure build-up on the piston chamber side (channel 2)	Items 130/131/135
	Restraint device on the annulus area side (channel 2)	Items 140/145
	Pressure limitation on the annulus area side against pressure intensification	Items 150/151
Basic functions	Safe reduced velocity below 10 mm/s according to ISO 16092-3, section 5.3.2	Items 170 ... 175
	Press force adjustment	Items 130 ... 132
	Load holding	Items 160 ... 165
Additional function	Rapid traverse due to own weight with prefill valve	Item 166

¹⁾ With exception, high-response valves with zero overlap RN and slide cushion ZN.

²⁾ From NG 35, only the tank port T1.1 arranged at the bottom is available

Function

Extension module 200

With the extension modules item 200, further common variants are available for selection. The extension modules item 200 are installed between the base module item 100 and the directional valve item 110 and their port pattern corresponds to the port pattern of the directional valve

item 110. When the extension modules item 200 are used, the safety of the hydraulic control is maintained. All actuator ports are arranged on the side. All measuring points are provided with two connections.

Variants		
	Rapid traverse with rapid traverse cylinder	Item 210
	Operation with high-pressure and low-pressure pumps	Item 220
	Rapid traverse with differential circuit	Item 230
	Accumulator operation	Item 240
	Slide cushion	Item 250
	Set-up by own weight (> 10 mm/s)	Item 260
	Load-sensing	Item 270
	Pressure holding on the piston chamber side	Item 280
	High-response valve with zero overlap without detection of direction	Item 290
	– Energy separation on the piston chamber side (channel 1)	
	– Energy separation on the annulus area side (channel 1)	

Installation

The pipelines must permanently withstand the maximum operating pressures and comply with the safety requirements according to ISO 16092-1, section 5.2.1 and section 5.2.3 as well as ISO 16092-3, section 5.2.3. Additionally it must be ensured that the pipeline between

the press module type "C" (port X2) and the annulus area is designed for the max. set pressure of the pressure relief valves (items 150/151). The pipeline design should be as short as possible.

Technical data

(For applications outside these values, please consult us!)

General	
Installation position	Vertical with directional valve item 110 on top
Safety-relevant on/off valves	Without manual override
Coating	Galvanic coating DIN EN ISO 19598 – Fe/Zn8//Cn/T0
Labelling	► Technical items
	► Outputs
Ambient temperature range	°C –20 ... +50
Storage temperature range	°C +10 ... +40
Storage time more than 6 months	Specify in plain text when ordering

Hydraulic				
Maximum operating pressure	► Ports ¹⁾ P1.1 ... P1.7, X1, X11, X12, PL, PE, HD, S, LS1, MX12.1	bar	Cast iron version	Steel version
	► Connection ¹⁾ X2	bar	315	350
Maximum return flow pressure	► Port ¹⁾ T1.1, T1.2	bar	350	400
	► Connection Y	bar	16	Separately at zero pressure to the tank
Recommended pilot pressure			30 ... 200	
Recommended load pressure		bar	20 ... 115 (other load pressures upon request)	
Measuring ports			Including measuring couplings	
Operating medium ²⁾			Mineral oil (HL, HLP) according to DIN 51524-1, other hydraulic fluids upon request	
Temperature range of the hydraulic fluid		°C	–20 ... +80, preferably +40 ... +50	
Viscosity range of the hydraulic fluid		mm ² /s	10 ... 500, preferably 30 ... 46	
Maximum admissible degree of contamination of the hydraulic fluid			Cleanliness class 18/16/13 according to ISO 4406 (c) ³⁾ Cleanliness class 17/15/12 according to ISO 4406 (c) for the pilot valve ⁴⁾ of 4WRDE	
Seal material			NBR, others upon request	

Sizes			10	16	25	32	35
Nominal flow ⁵⁾	► P1	l/min	140	300	600	1000	2000
	► HD	l/min	70	130	260	–	–
	► X1→T	l/min	250	500	700	1200	2100
	► X2→T1 ⁶⁾	l/min	140	300	600	1000	2000
Recommended pump equipment ⁷⁾		cm ³	100	210	355	2 x 355	4 x 355

- 1) Order connection flanges separately, see page 42.
- 2) The ignition temperature of the operating medium used must be higher than the maximum coil temperature of the valves. See data sheets of the components used.
- 3) Effective filtration is to be provided separately. This prevents faults and simultaneously increases the service life of the components. See data sheets of the components used.
- 4) Flushing element to be ordered separately, HSA06A012-4X/V00 (R901092348) or 4WE6J6X/EG24N9K4 (R900561288).
- 5) The directional valve item 110 determines the maximum flow and maximum hydraulic performance of press module.
- 6) Design the rapid traverse due to own weight with prefill valve with at least 25 bar load holding pressure. Below 25 bar upon request.
- 7) For recommended pump versions, see pages 43 and 44.

Notice:

In the as-delivered state, the mechanical adjusters of the pressure relief valves (items 121, 131, 150/151, 165) and the stroke limitations (items 140 and 161) are completely screwed-out.

In the as-delivered state, the type-tested safety valve item 246 (only available with accumulator operation) is set and sealed according to the Pressure Equipment Directive 2014/68/EU.

Technical data

(For applications outside these values, please consult us!)

Electric		
Voltage type		Direct voltage
Duty cycle	%	100
Protection class according to DIN EN 60529		IP65 with mating connector mounted and locked ¹⁾
Maximum surface temperature of the coil ²⁾	°C	150
Voltage	V	24 +/- 10%



Notice:

With the electrical connection "K4", the protective grounding conductor (PE) must be connected properly.

High-response valves ³⁾		
Voltage	V	24 +/- 10%
Command value input	V	+/- 10%
Control electronics		On Board Electronic (OBE)

- 1) Mating connectors are not included in the scope of delivery and must be ordered separately. See data sheet 08006.
- 2) Due to the temperatures occurring at the surfaces of the solenoid coils, the standards ISO 13732-1 and EN ISO 4413 must be observed.
- 3) For function, technical data, integrated control electronics, performance limits, characteristic curves and general information refer to the data sheet of the component used.



Notice:

For the environment simulation testing for EMC (electro-magnetic compatibility), climate and mechanical load, see data sheet of the component used.

Safety-relevant components

For information on the electrical characteristics of the inductive position switches such as connection voltage, load capacity, admissible residual ripple, switching

outputs and pin connections please refer to the data sheets listed in the following table:

Technical item	Type designation	IH04C-6X	Limit switch designation	Data sheet
Item 110	5-4WE10...QS0	NG10	S11a, S11b, S12, S23	24830
	H-4WEH...QM0	NG10-32		
	4WREEM	NG10		
	4WRTEM	NG10-35	S11	29083
Items 135, 260, 292, 297	4WE6...QMB	NG10-32	S13, S26, S29.2, S29.7	24830
	5-4WE10...QMB	NG35		
Item 140	LFA...E...QM	NG10-35	S14	21015
Item 250	H-3WEH...QMB	NG10-35	S25	24830
Items 290, 295	LC2A...B...Q7	NG10-35	S29.0, S29.5	21040

Characteristic curves

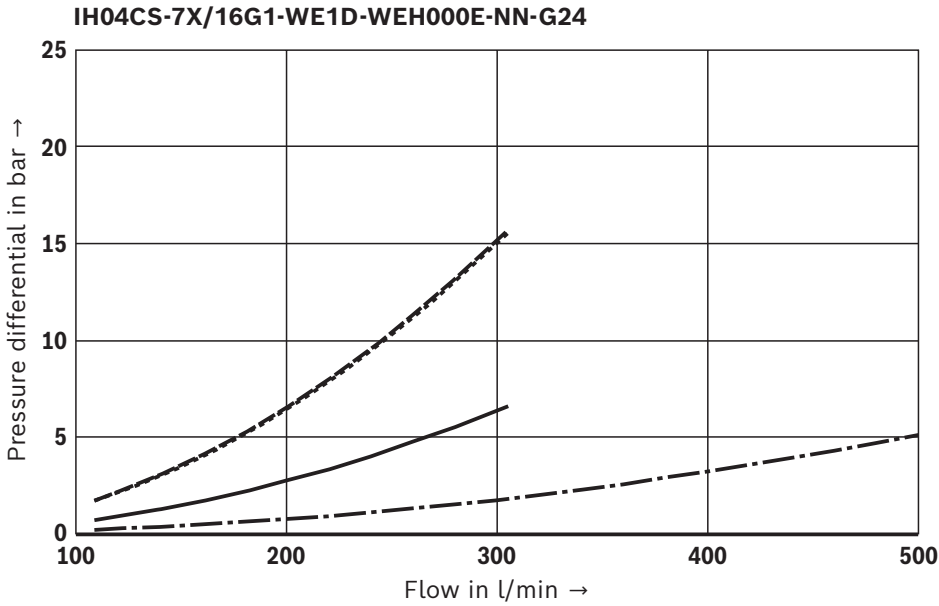
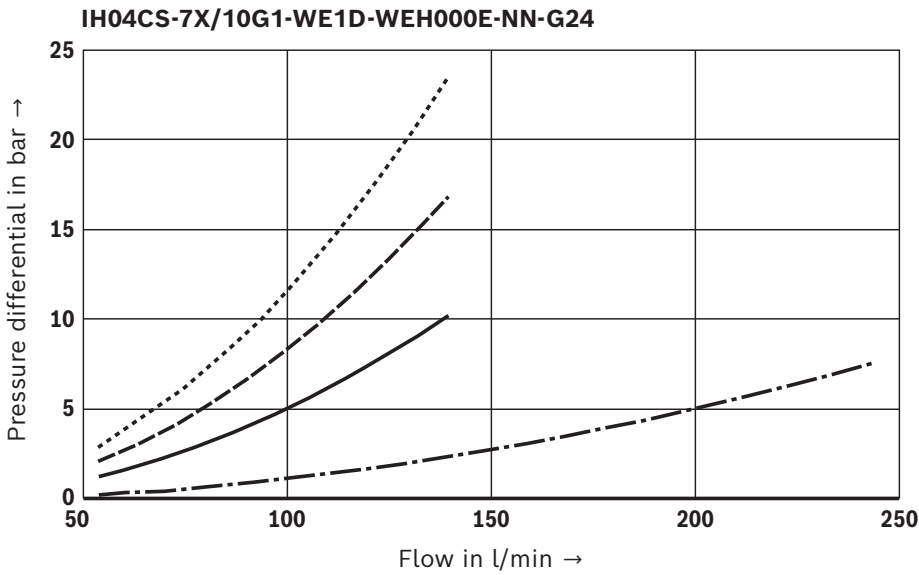

- P1 → X1
- - - P2 → X2
- · - X1 → T1.1
- X2 → T1.1

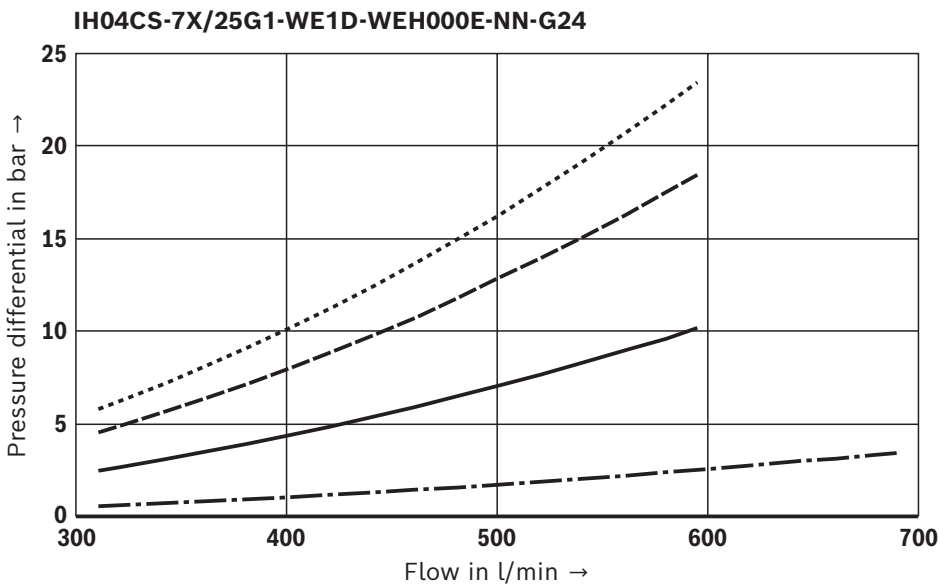

Characteristic curves

IH04CS-7X/32G1-WE1D-WEH000E-NN-G24

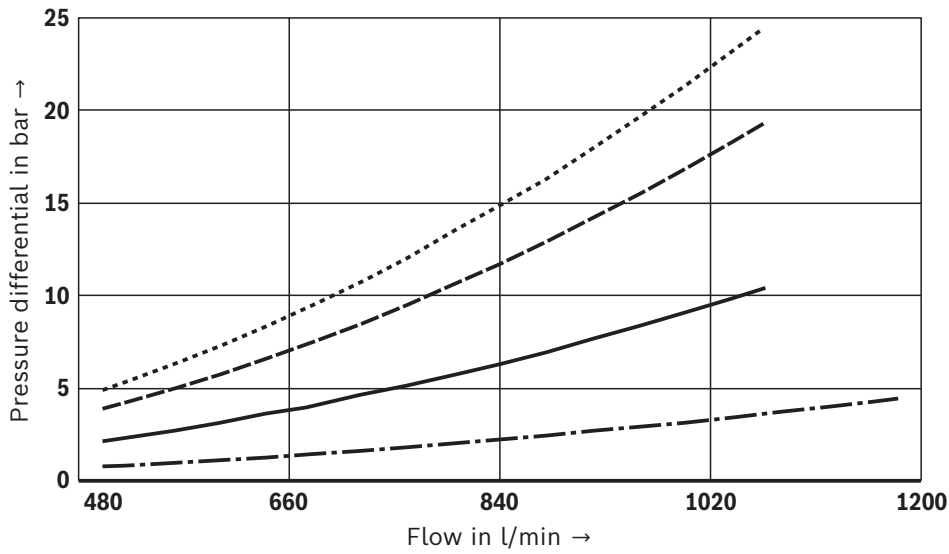

IH04CS-7X/35G1-WE1D-TEM1K3E-NN-G24

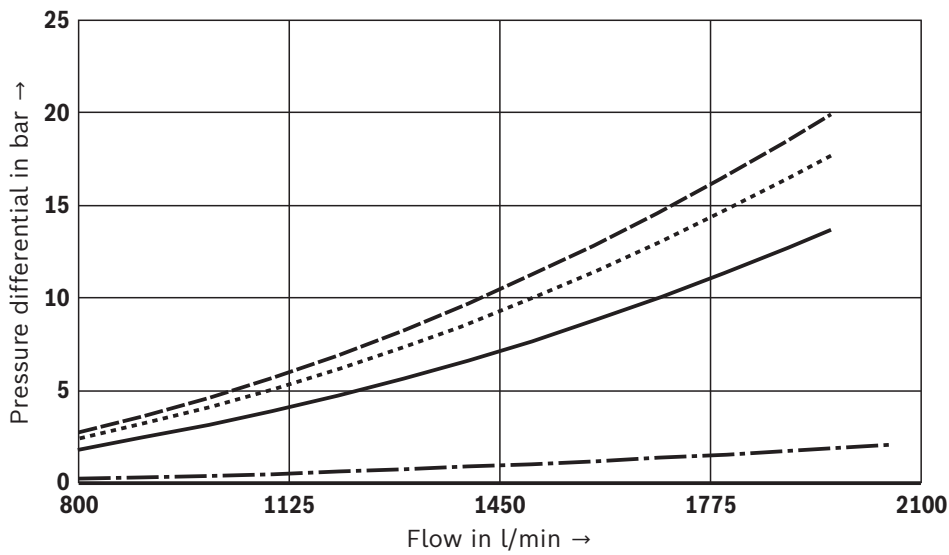

- P1 → X1
- - - P2 → X2
- · - · X1 → T1.1
- · · X2 → T1.1

Basic functions according to safety category 4 (ISO 13849-Pl e):

IH04CS-7X/...1-WE0N-WEH000E-NN-G24

The following description is based on a cyclic control and position monitoring of the valves.

- ▶ Failure of any of the position-monitored valves must be detected by an external safety PLC and the start of the next dangerous movement after an error has to be prevented. Direction error immediate stop.
- ▶ The load holding pressure is the total of slide weight and weight of the top tool part acting on the effective annulus area.
- ▶ During muting (e.g. during retraction), the solenoids Y13 (S13) and Y14 (S14) must be switched-off.

Option W – Item 120

The pressure relief valve item 120/121 limits the pressure of the motor pump station. At the pressure relief valve item 121, the maximum operating pressure is set. The on/off valve item 122 provides pilot control of the pressure relief valve item 120/121. In its basic position, the pressure relief valve item 120/121 is switched to depressurized circulation. Energization of the solenoid Y12 causes the pressure set at the pressure relief valve item 120 to become effective..

Option WEH000E – Item 110

The movement direction of the cylinder piston is determined by the directional valve item 110:

- ▶ The cylinder piston is extended with the control signal Y11b.
- ▶ The cylinder piston is retracted with the control signal Y11a.

By means of the position monitoring S11a and S11b, it is monitored whether

- ▶ the closed central position is reached in every pressing cycle.
- ▶ the movement direction is correct.

Option E – Item 130

The pressure relief valve item 130/131 serves for pressure limitation on the piston chamber side of the cylinder.

At the pressure relief valve item 131, the maximum press pressure is set. The proportional pressure relief valve item 132 provides pilot control of the pressure relief valve item 130/131 and determines the press pressure by means of the control signal Y13.1 (e.g. press force, decompression, preload during retraction):

- ▶ When the set pressure is exceeded, the pressure relief valve item 130 will open to the tank.
- ▶ When the set pressure is no longer reached, the pressure relief valve item 130 will close.

Functional safety item 135

Protection against unwanted pressure build-up on the piston chamber side is realized by the directional valve item 135. In its basic position, the pressure relief valve item 130/131 is switched to depressurized circulation. By means of the electrical position monitoring S13 it can be monitored whether the basic position is reached in every pressing cycle. Energization of the solenoid Y13 causes the pressure set at the pressure relief valve item 132 to become effective.

Functional safety item 140

The 2-way cartridge valve in item 140 holds the cylinder piston in position (EN ISO 16092-3 section 5.3.7.2). During load holding/retraction, the valve item 140 acts as a check valve and during extension as a switchable isolator valve. By means of the position monitoring S14 it is monitored whether the basic position is reached in every pressing cycle. The seat valve item 145 unlocks the 2-way cartridge valve item 140 during extension.

Functional safety item 150

The pressure relief valves items 150/151 serve as protection against pressure intensification in the annulus area of the cylinder. According to DIN ISO 16092-3 section 5.2.3.3, they must be set to at least 10% above the maximum operating pressure item 120 and sealed.

Option 0 – Item 160

During the pressing process, the pressure relief valve consisting of items 160/161/165 compensates the load holding pressure on the annulus area side. The pressure relief valve item 165 is to be set so that the cylinder piston does not drop during standstill:

- ▶ When the set pressure is exceeded, the pressure relief valve item 160 will open to the tank.
- ▶ When the set pressure is no longer reached, the pressure relief valve item 160 will close.

Basic functions according to safety category 4 (ISO 13849-Pl e):
 IH04CS-7X/...1-WE0N-WEH000E-NN-G24

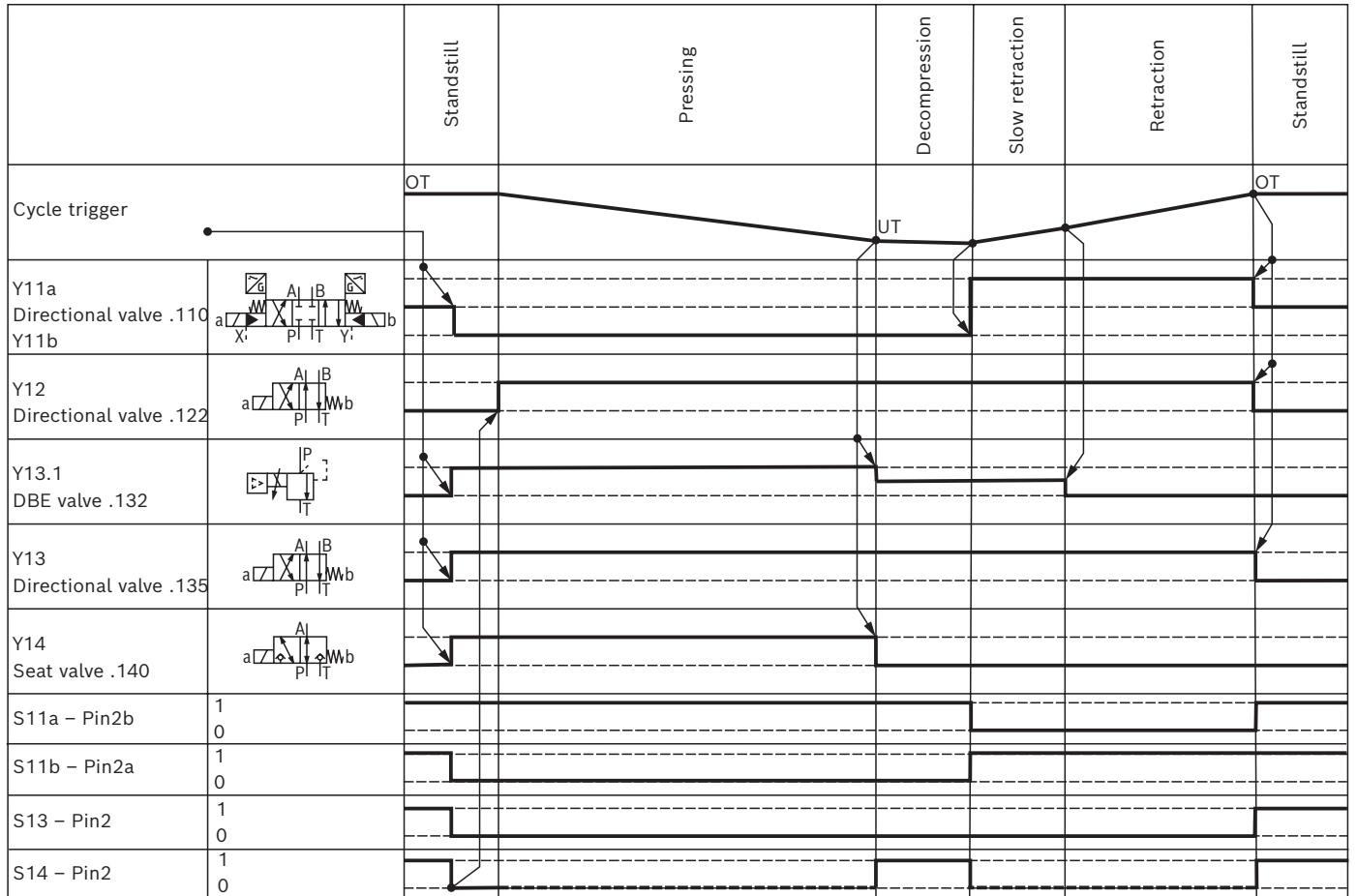

Basic functions according to safety category 4 (ISO 13849-Pl e):
 IH04CS-7X/...1-WE0N-WEH000E-NN-G24

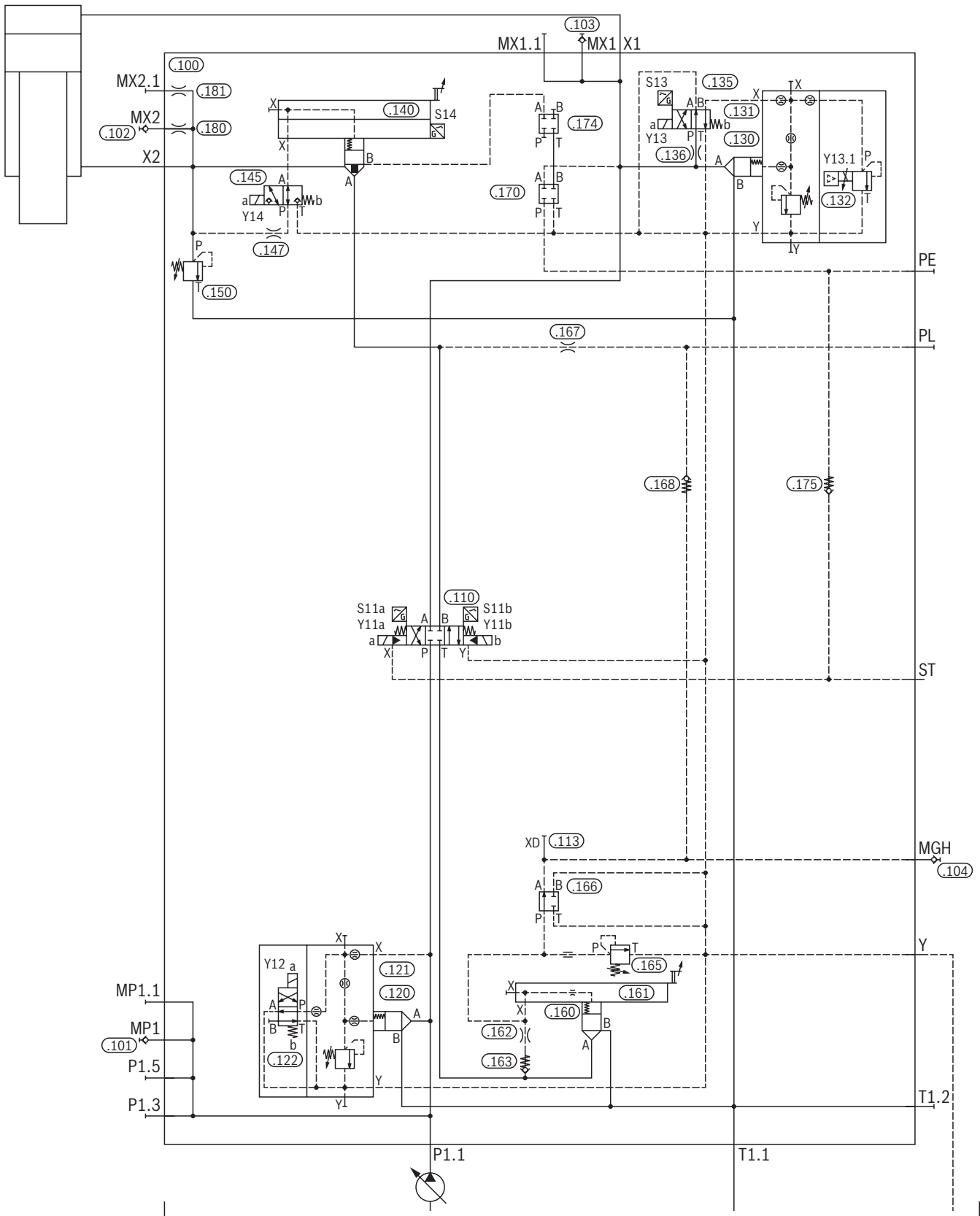

Rapid traverse due to own weight with prefill valve: IH04CS-7X/...1-WE1N-WEH000E-NN-G24

Option 1 – Item 160

During the pressing process, the pressure relief valve consisting of items 160/161/165 compensates the load holding pressure on the annulus area side. The pressure relief valve item 165 is to be set so that the cylinder piston does not drop during standstill:

- ▶ When the set pressure is exceeded, the pressure relief valve item 160/161 will open to the tank.
- ▶ When the set pressure is no longer reached, the pressure relief valve item 160/161 will close.

The valve item 166 provides pilot control for the rapid traverse phase and the load-holding pressure compensation:

- ▶ In basic position (Y16 – OFF) the load holding pressure compensation takes effect
- ▶ With energization of the solenoid (Y16 – ON), the rapid traverse phase without load holding pressure compensation takes effect.

Using the stroke limitation at the logic cover item 161, the maximum rapid traverse velocity is set.

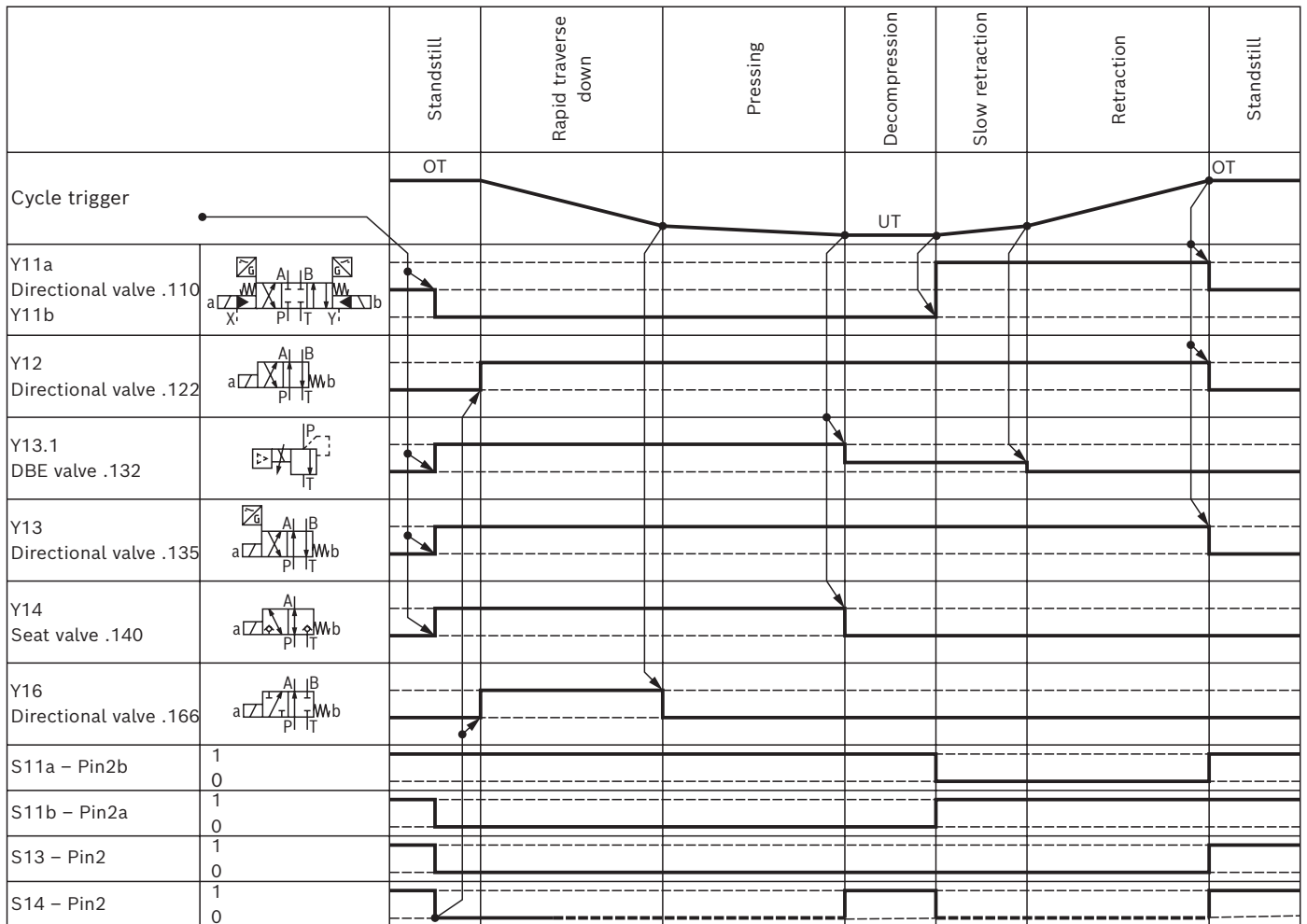

Rapid traverse with rapid traverse cylinder: IH04CS-7X/...2-WE0N-WEH000E-EN-G24

Option 1 – Item 210

The 2-way cartridge valve consisting of item 210/211 separates the rapid traverse piston chamber from the pressing piston chamber. With energization of the solenoid (Y21 – ON), the cartridge valve item 210/211 closes. The rapid traverse phase takes effect. At the end of rapid traverse, valve item 212 is de-energized, the 2-way cartridge valve item 210/211 opens.

The hydraulic pressure is applied to both piston areas. The end of the pressing process is followed by joint decompression. During retraction, the oil volume flows from the rapid traverse piston chamber via the 2-way cartridge valve item 210/211 to the pressing piston chamber and via the prefill valve to the tank.

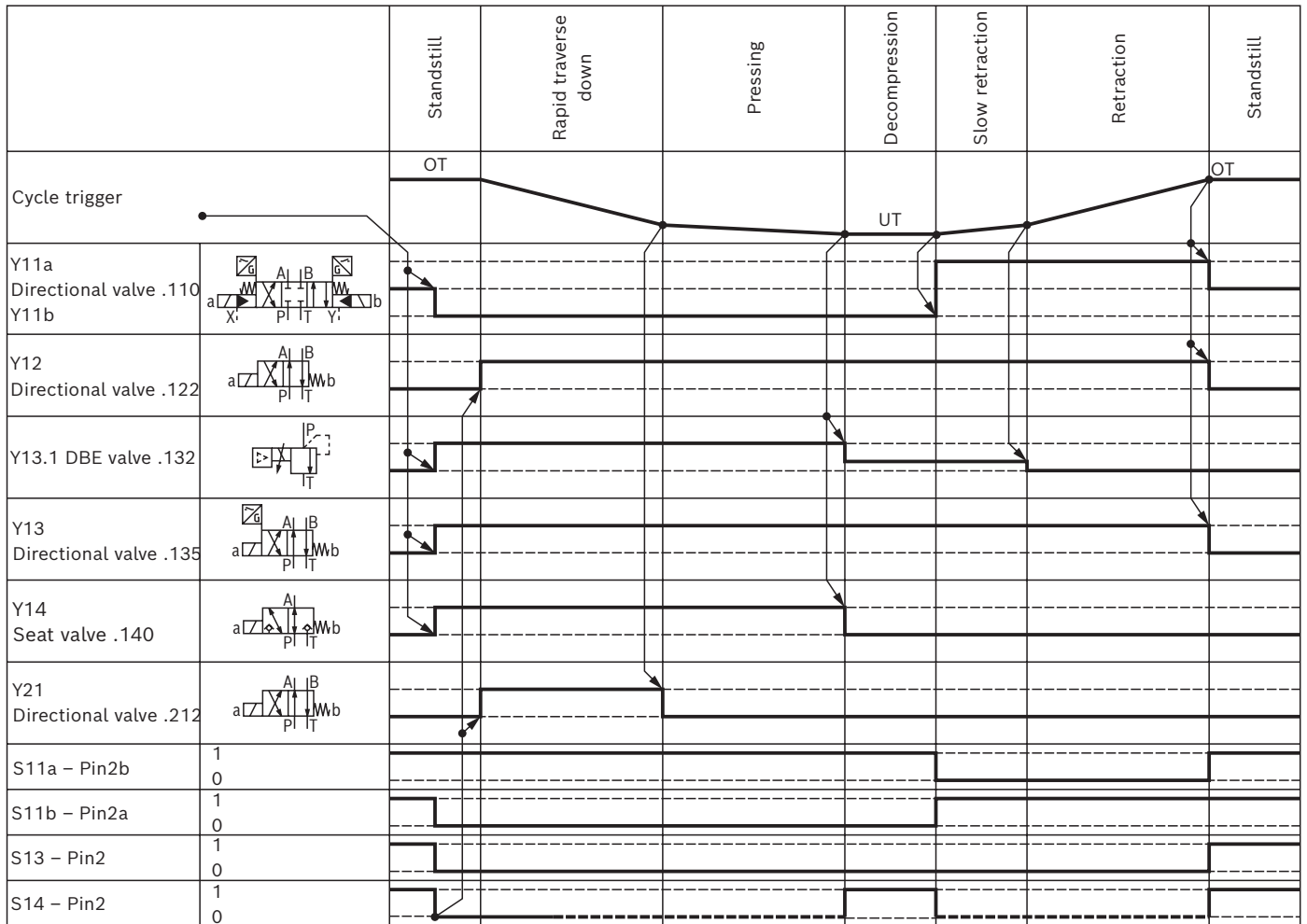

Rapid traverse with differential circuit: H04CS-7X/...2-WE0N-WEH000E-DN-G24

Option 0 – Item 165

The pressure relief valve item 165 limits the pressure of the tank line item 110 and is to be set to the maximum pressure rating.

Option DN – Item 230

During the rapid traverse phase, the 2-way cartridge valve consisting of the items 230/231 compensates the load holding pressure. The pressure relief valve item 236 is to be set so that the cylinder piston does not drop during standstill.

The valve item 235 provides pilot control for the rapid traverse and the pressing process:

- ▶ With energization of the solenoid (Y23 – ON), the load holding pressure compensation takes effect during the rapid traverse via the pressure relief valve item 230/231/236 from the annulus area to the piston chamber.
- ▶ In basic position (Y23 – OFF), the load holding pressure compensation takes effect during the pressing process via the pressure relief valve item 160/161/236 from the annulus area to the tank.

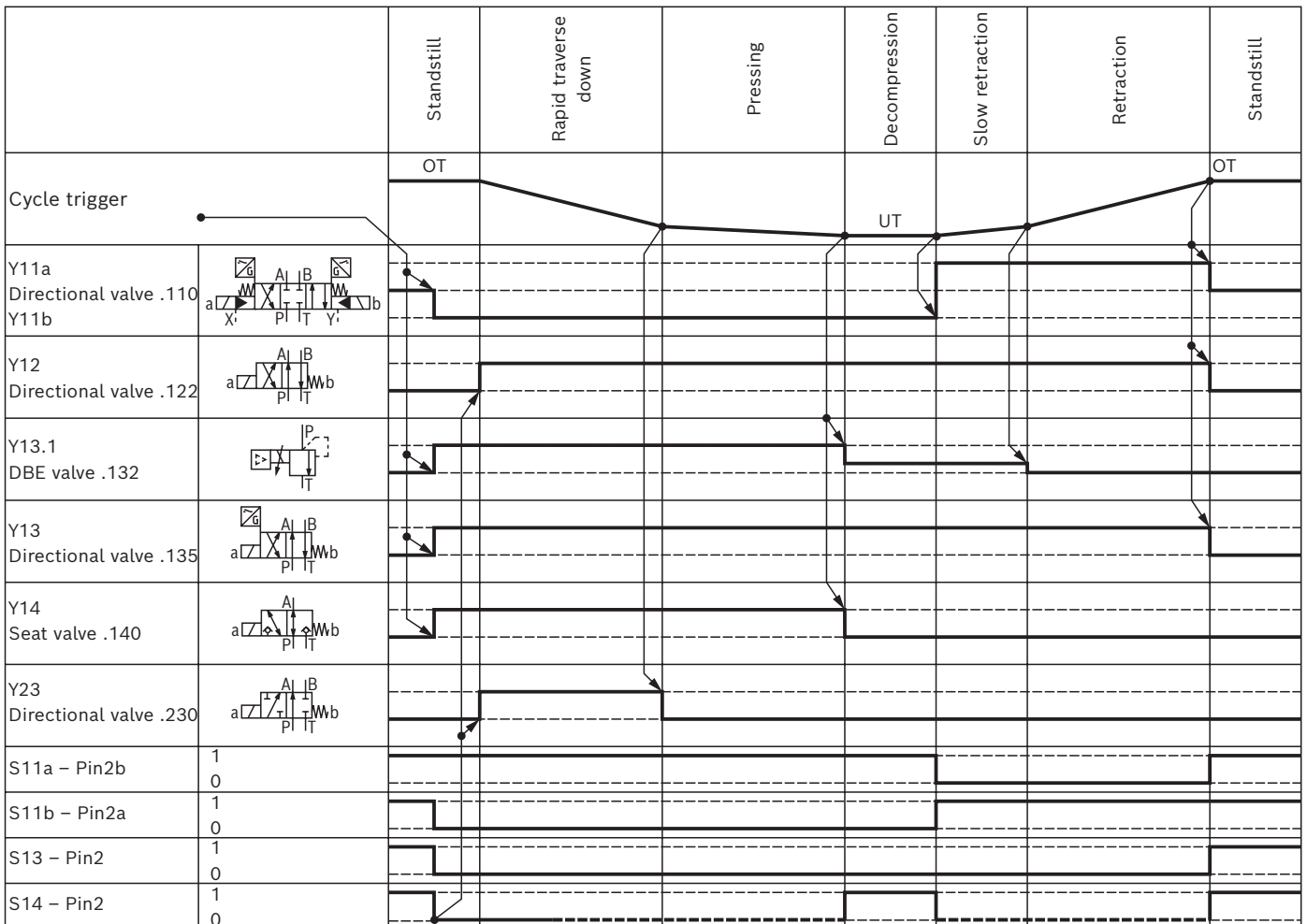

Rapid traverse with differential circuit: H04CS-7X/...2-WE0N-WEH000E-DN-G24

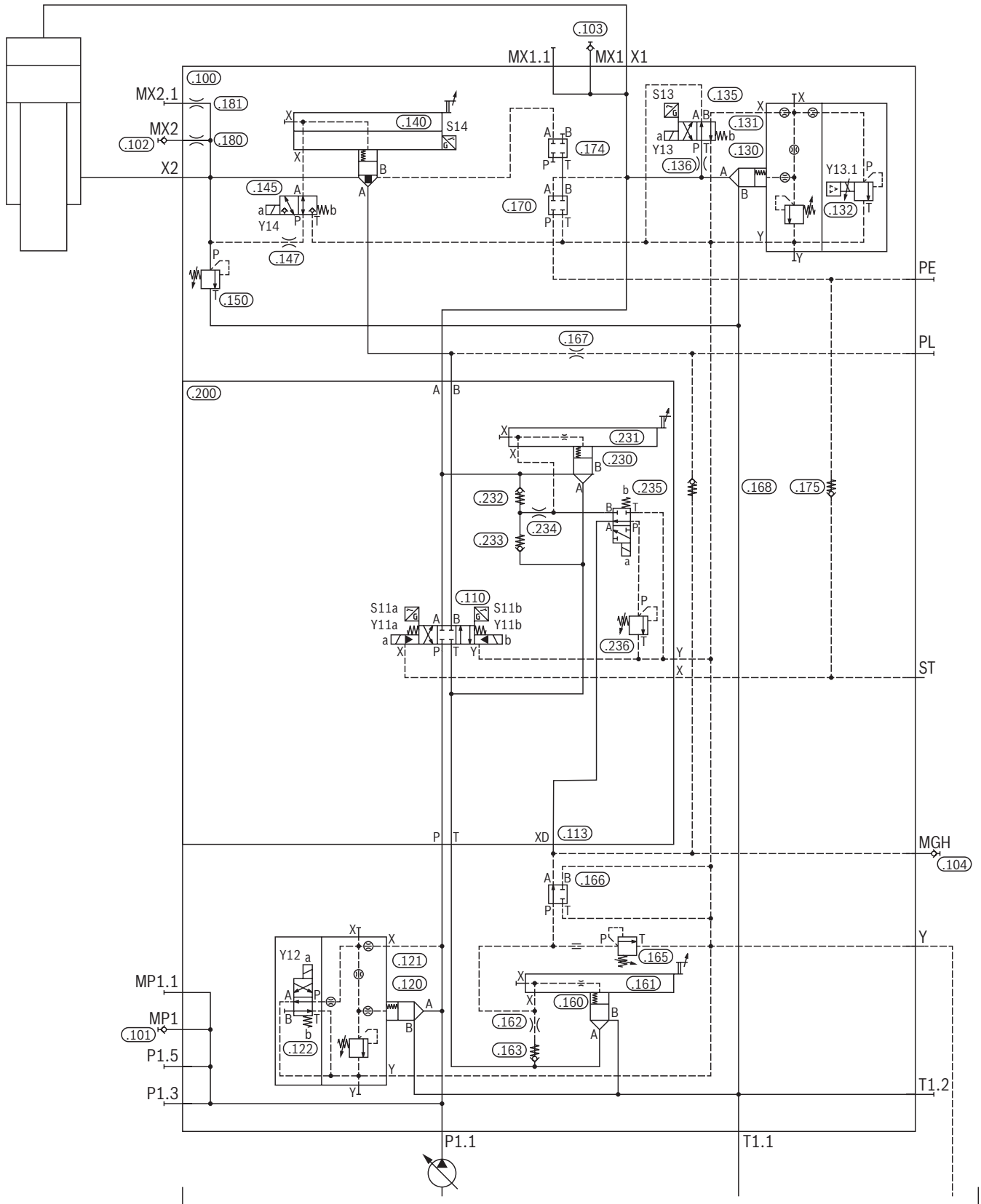

Operation with high- and low-pressure pumps: IH04CS-7X/...2-WE0N-WEH000E-HN-G24

Option W – Item 120

The pressure relief valve item 120/121 limits the pressure of the low-pressure motor pump station (hydraulic energy supply). At the pressure relief valve item 121, the maximum operating low-pressure is set. The on/off valve item 122 provides pilot control of the pressure relief valve item 120/121. In its basic position, the pressure relief valve item 120/121 is switched to depressurized circulation. Energization of the solenoid Y12 causes the pressure set at the pressure relief valve item 121 to become effective.

Option HN – Item 220

The pressure relief valve consisting of the items 220/221 limits the pressure of the high-pressure motor pump station (hydraulic energy supply). At the pressure relief valve item 221, the maximum operating high-pressure is set. The on/off valve item 222 provides pilot control of the pressure relief valve item 220/221. In its basic position, the pressure relief valve item 220/221 is switched to depressurized circulation. Energization of the solenoid Y22 causes the pressure set at the pressure relief valve item 122 to become effective.

The check valve item 225 separates the high-pressure and low-pressure circuits

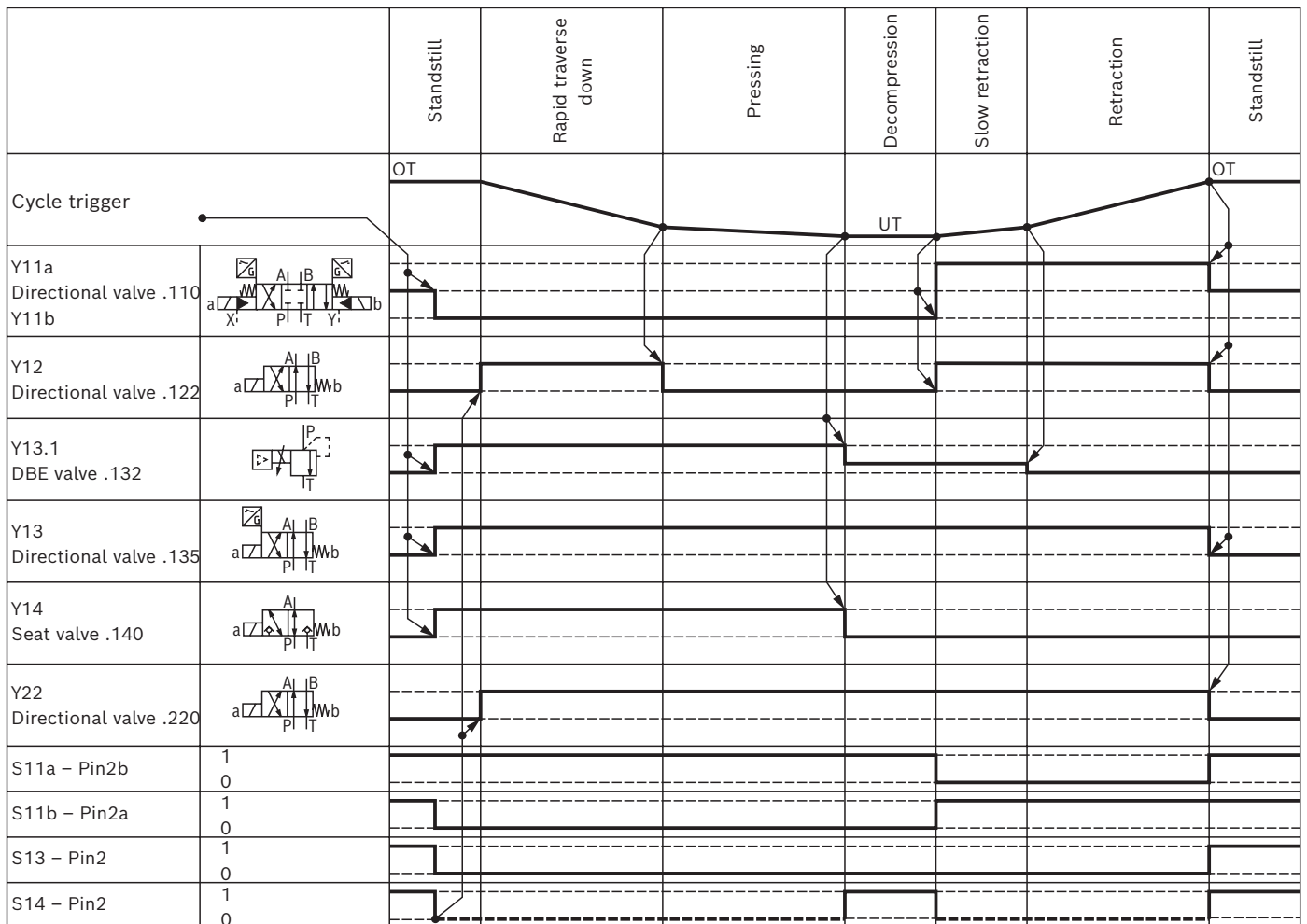

Operation with high- and low-pressure pumps: IH04CS-7X/...2-WE0N-WEH000E-HN-G24

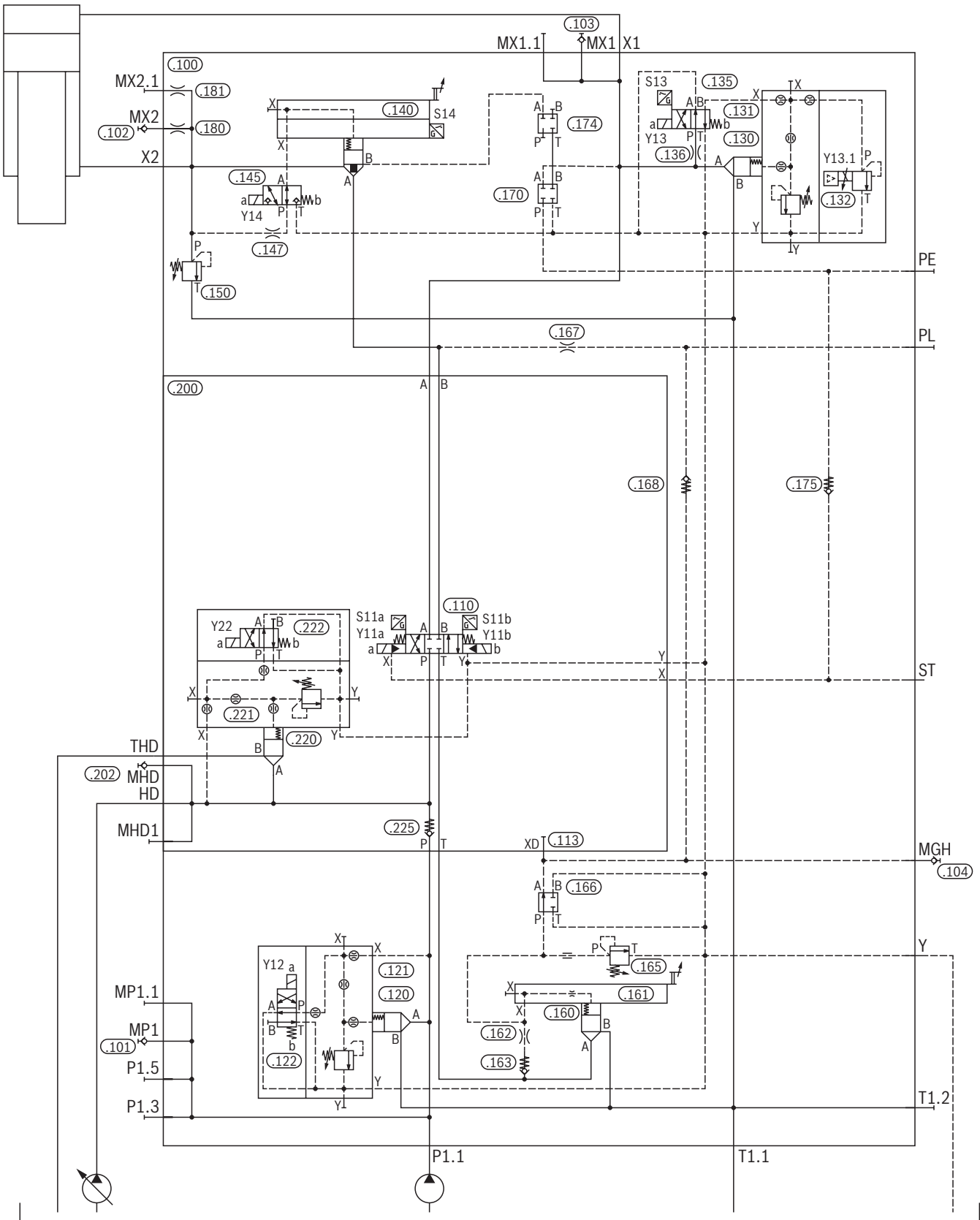

Load-sensing: IH04CS-7X/...2-BE0N-TEM...E-LN-G24

The load-sensing function is achieved together with the flow controller of the pump.

Option B – Item 120

The pressure relief valve consisting of the items 120/121 limits the pressure of the motor pump station (hydraulic energy supply). At the pressure relief valve in item 121, the maximum operating pressure is set.

Option TEM...E – Item 110

The stepless flow adjustment of the pump and the movement direction of the cylinder piston are determined by the proportional directional valve item 110.

Option LN – Item 270

The valve item 276 determines the operating mode of the pump:

- ▶ In the de-energized standby position, the flow controller pressure is effective and can be set. Also the pump is swiveled in. A pressure up to 22-25 bar improves the control quality at lower velocities and avoids the need for a pilot oil pump.
- ▶ By energization of the solenoid (Y27.1-ON), the pilot oil circuit is supplied with oil at the set flow controller pressure.

Valve item 275 determines load-sensing:

- ▶ In the de-energized position, the pilot oil circuit is supplied with oil up to the set flow controller pressure.
- ▶ With energization of the solenoid (Y27-AN), the load-sensing takes effect. The highest pressure effective at port A or B of the proportional directional valve item 110 is connected via the shuttle valve item 270 to the flow controller of the pump.

Load-sensing: IH04CS-7X/...2-BE0N-TEM...E-LN-G24

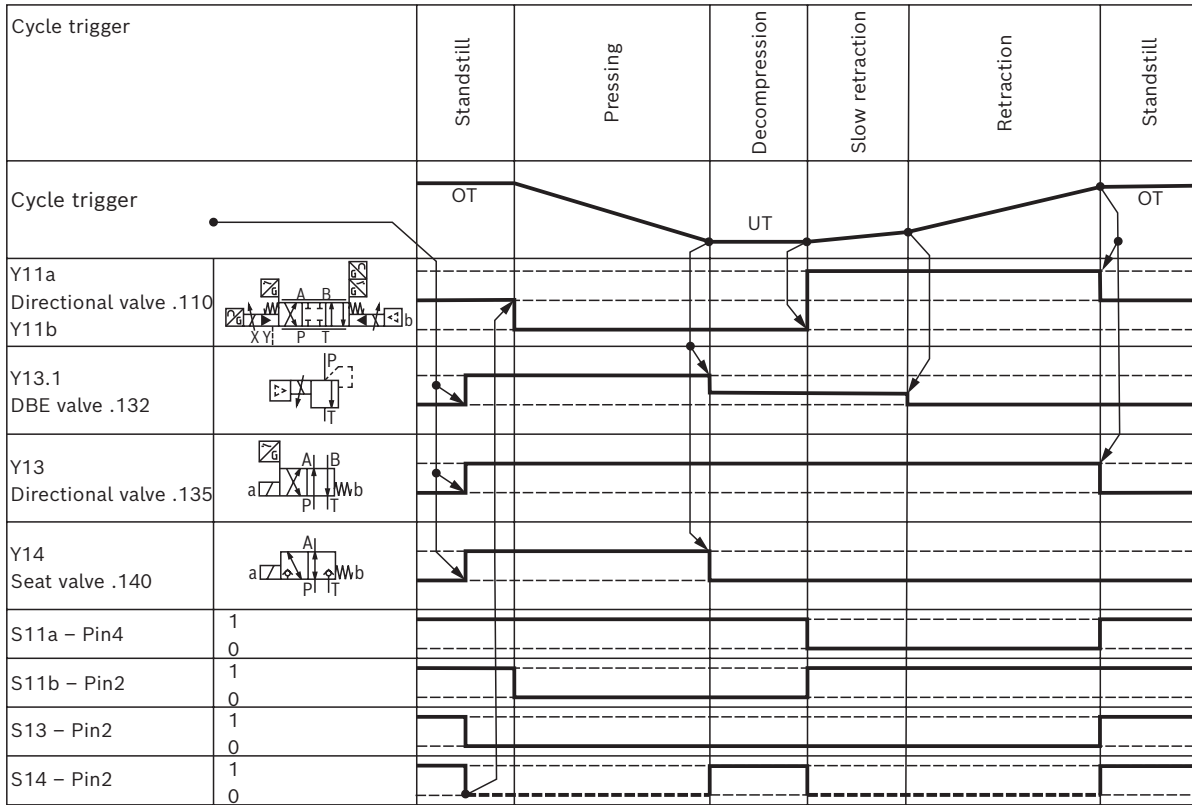

The solenoids Y27.1, Y27.2 are permanently switched.

Load-sensing: IH04CS-7X/...2-BE0N-TEM...E-LN-G24

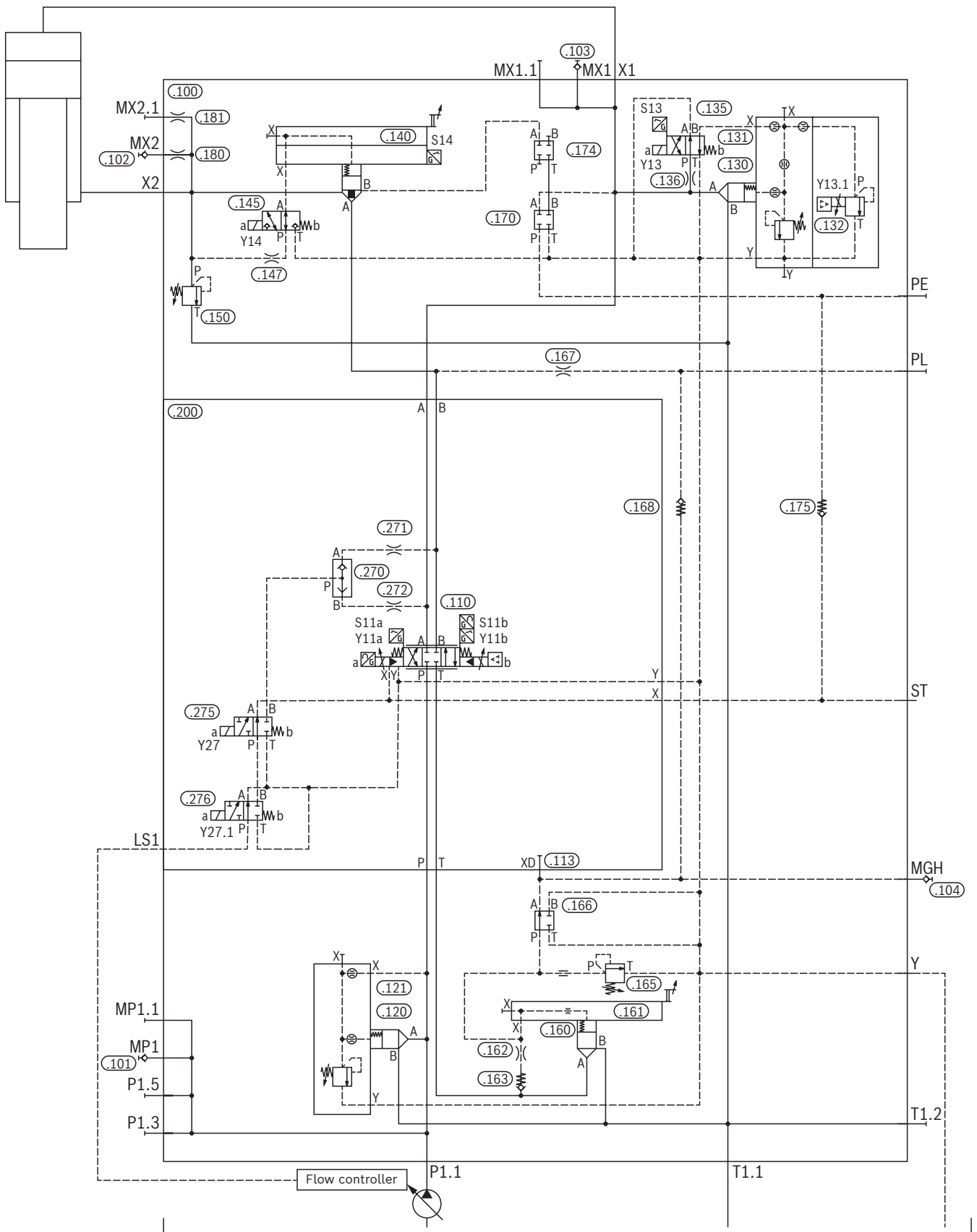

High-response valve with zero overlap: IH04CS-7X/...3-WE3N-RDE...V-RN-G24

Option RDE...V – Item 110

The stepless flow adjustment and the movement direction of the cylinder piston are determined by the high-response valve item 110. The highly dynamic high-response valve item 110 is recommended for alternating pressure, force, position and velocity controls and has a control spool with zero overlap.

Option 3 – Item 105

During the pressing process, the pressure relief valve item 195 compensates the load holding pressure on the annulus area side. The pressure relief valve item 195 is to be set so that the cylinder piston does not drop during standstill. The valve item 196 provides pilot control for the rapid traverse phase and the load-holding pressure compensation:

- ▶ In basic position (Y19-OFF), the load holding pressure compensation takes effect via the pressure relief valve item 195
- ▶ With energization of the solenoid (Y19-ON), the rapid traverse phase via the 2-way cartridge valve item 190/192 without load holding pressure compensation takes effect. Using the stroke limitation at the logic cover item 191, the maximum rapid traverse velocity is set. Retraction is realized via the check valve item 198.

Option RN – Item 290

The energy separation against unwanted pressure build-up on the piston chamber side is realized by the 2-way cartridge valve item 290. By means of the position monitoring S29.0 it is monitored whether the basic position is reached in every pressing cycle. The directional valve item 292 (Y29.2-ON) unlocks the 2-way cartridge valve item 290. In basic position, the directional cartridge valve item 290 is closed.

The 2-way cartridge valve item 295 holds the cylinder piston in position (see EN ISO 16092-3 section 5.3.7.2). By means of the position monitoring S29.5 it is monitored whether the basic position is reached in every pressing cycle. The directional valve item 297 (Y29.7-ON) unlocks the 2-way cartridge valve item 295. In basic position, the 2-way cartridge valve item 295 is closed.

High-response valve with zero overlap: IH04CS-7X/...3-WE3D-RDE...V-RN-G24

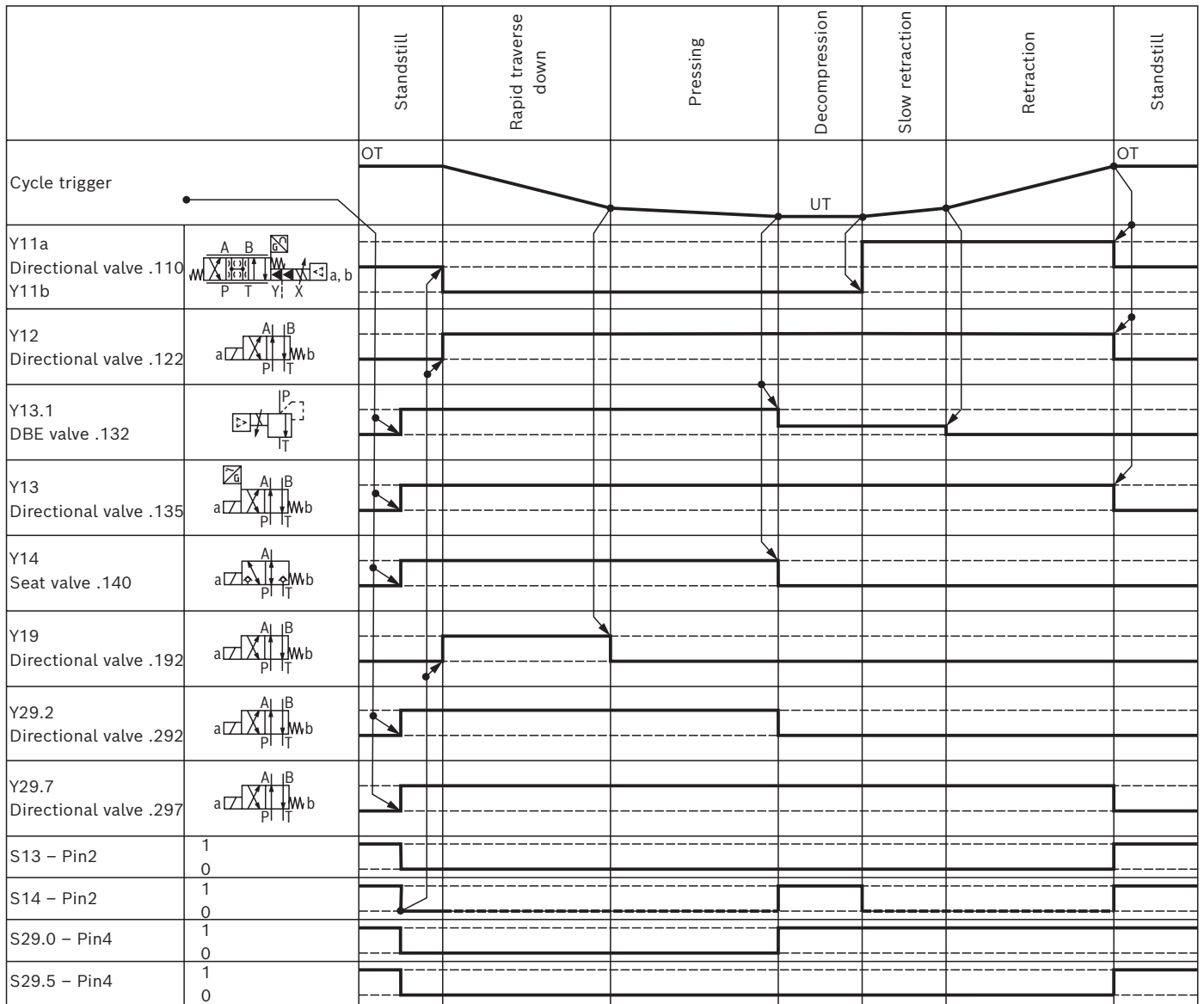

The solenoid Y16 is switched permanently

High-response valve with zero overlap: IH04CS-7X/...3-WE3N-RDE...V-RN-G24

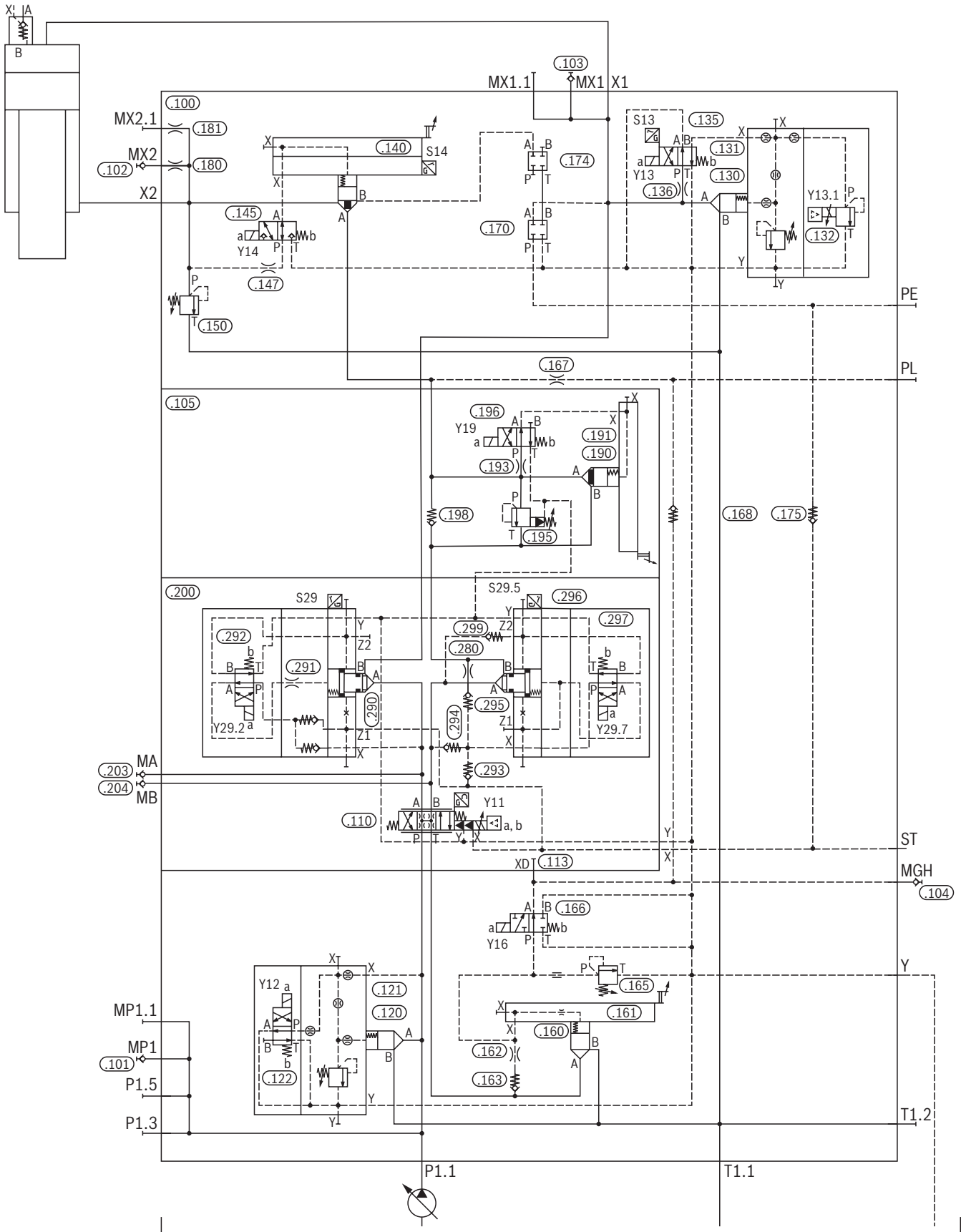

Pressure holding on the piston chamber side: IH04CS-7X/...3-WE2N-WEH000E-XN-G24

Option 2 – Item 105

During the pressing process, the pressure relief valve item 195 compensates the load holding pressure on the annulus area side. The valve item 195 is to be set so that the cylinder piston does not drop during standstill. Retraction is realized via the check valve item 198.

Option XN – Item 280

In the basic position, the 2-way cartridge valve consisting of the items 280/281 acts as a check valve. The pressure is built up on the piston chamber side by the cylinder up to the system pressure and then maintained in a leakage-free manner.

Energization of the solenoid (Y28-ON) unlocks the 2-way cartridge valve item 280/281 at the valve item 282 and triggers the decompression.

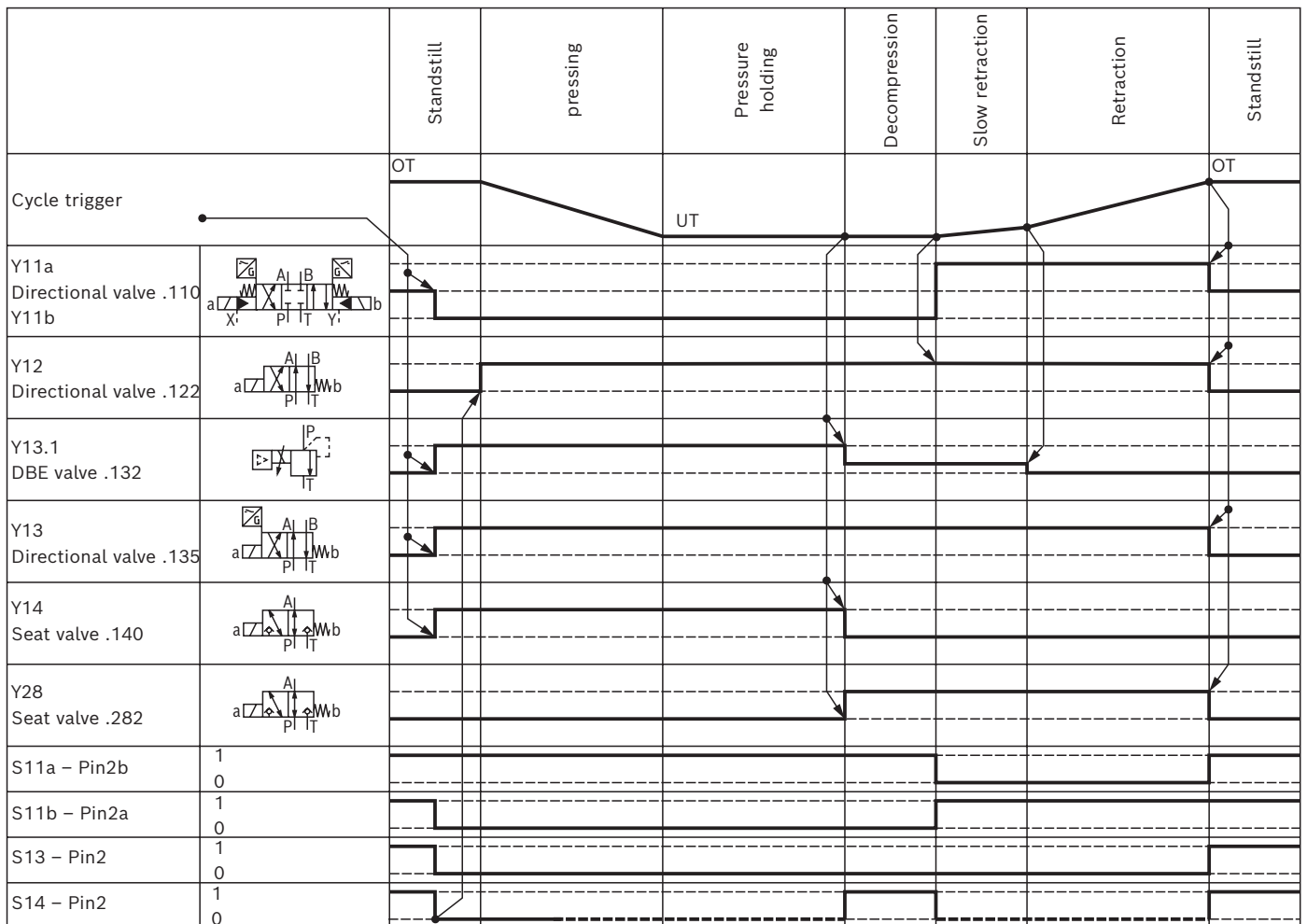

Except for during decompression and slow retraction, the solenoid Y16 is switched permanently

Pressure holding on the piston chamber side: IH04CS-7X/...3-WE2N-WEH000E-XN-G24

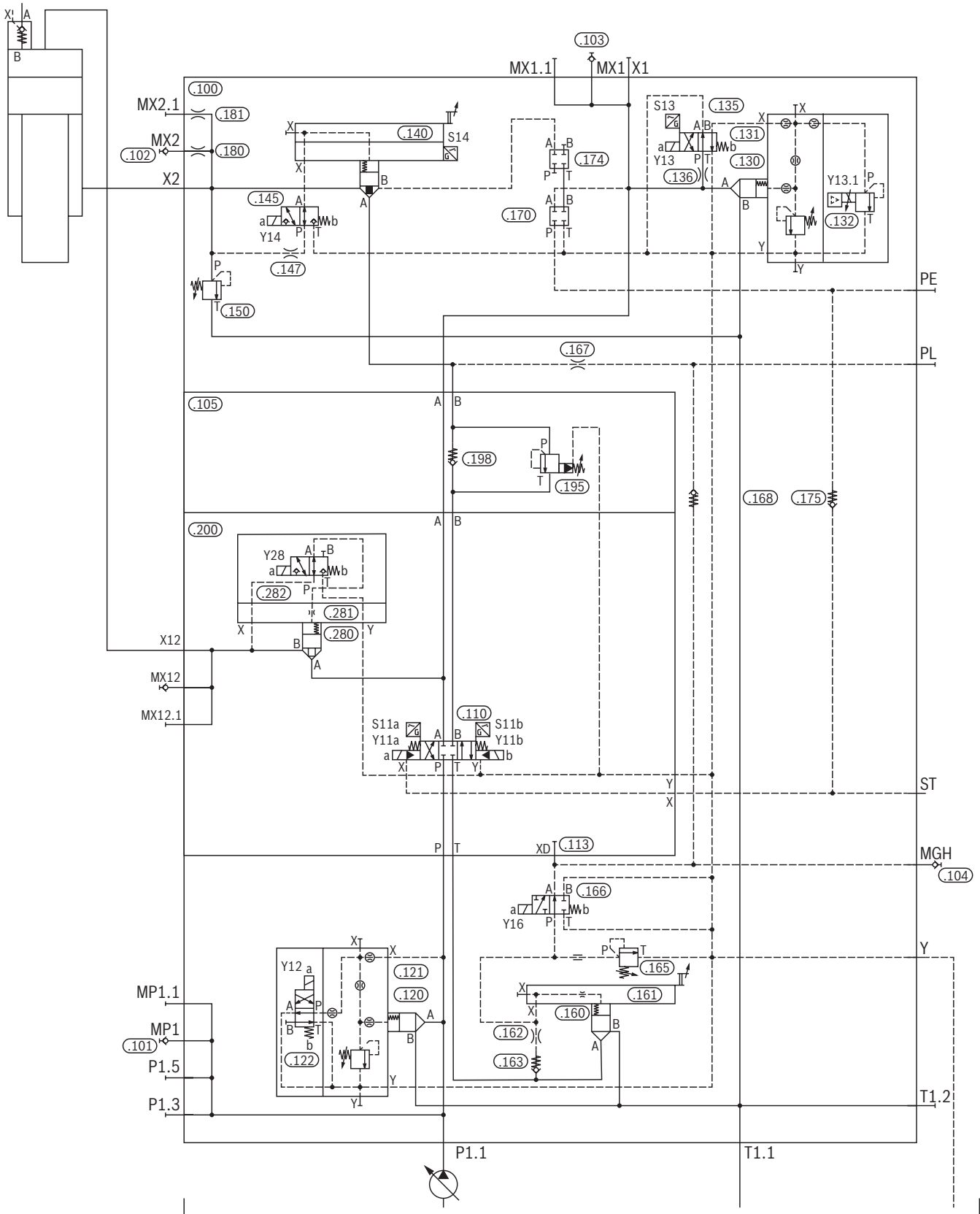

Accumulator operation: IH04CS-7X/...2-WE0N-TEM...E-SN-G24

Option SN – Item 240

The on/off valve item 240 selects between pump operation (Y24 - OFF) and accumulator operation (Y24 - ON).

The 2-way cartridge valve consisting of item 243/244 shuts off the accumulator circuit. The seat valve item 245 provides pilot control of the 2-way directional valve item 243/244:

- ▶ In basic position (Y24.1 - OFF), the blocking is effective in both directions;
- ▶ With energization of the solenoid (Y24.1 – ON), the accumulator circuit takes effect.

The stroke limitation at the logic cover item 242 limits the flow at the accumulator. The continuous flow adjustment is achieved via the proportional valve item 110.

The assembly item 246 to item 248 comprises all the equipment that is required according to EN 14359 for safety of accumulators:

- ▶ The maximum pressure limitation is achieved by the type-tested pressure relief valve item 246
- ▶ The manual unloading is achieved using the rotary knob at the pressure relief valve item 246.
- ▶ The electrical unloading is achieved using the orifice and the seat valve item 247. In energized condition (Y24.2 - ON), the pressure set at the pressure relief valve item 121 takes effect.
- ▶ The charge state of the accumulator is visually indicated by the pressure gauge item 248 with red marking of the limit pressure.

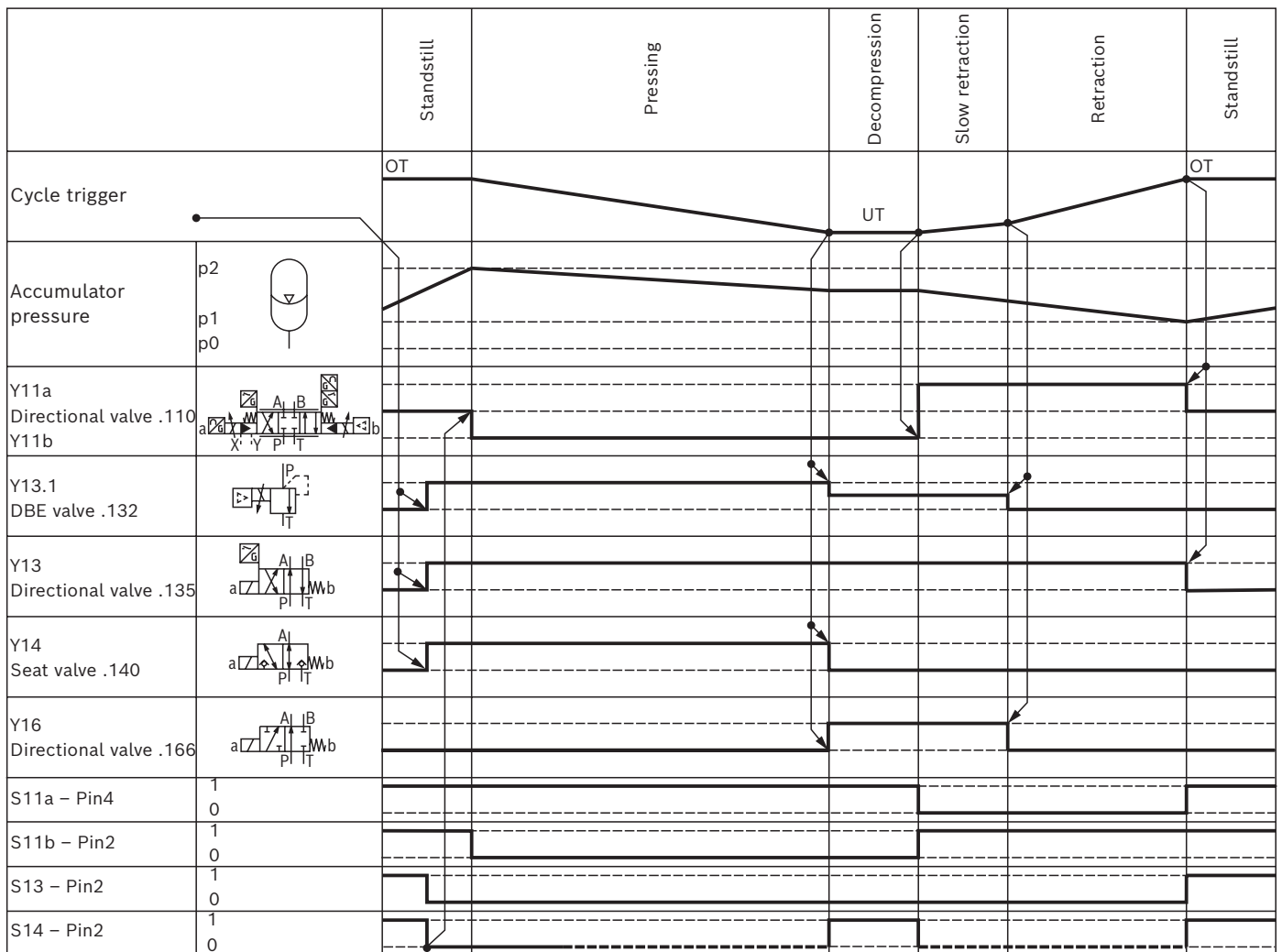

The solenoids Y12, Y24, Y24.1 and Y24.2 are permanently switched.

Accumulator operation: IH04CS-7X/...2-WEON-TEM...E-SN-G24

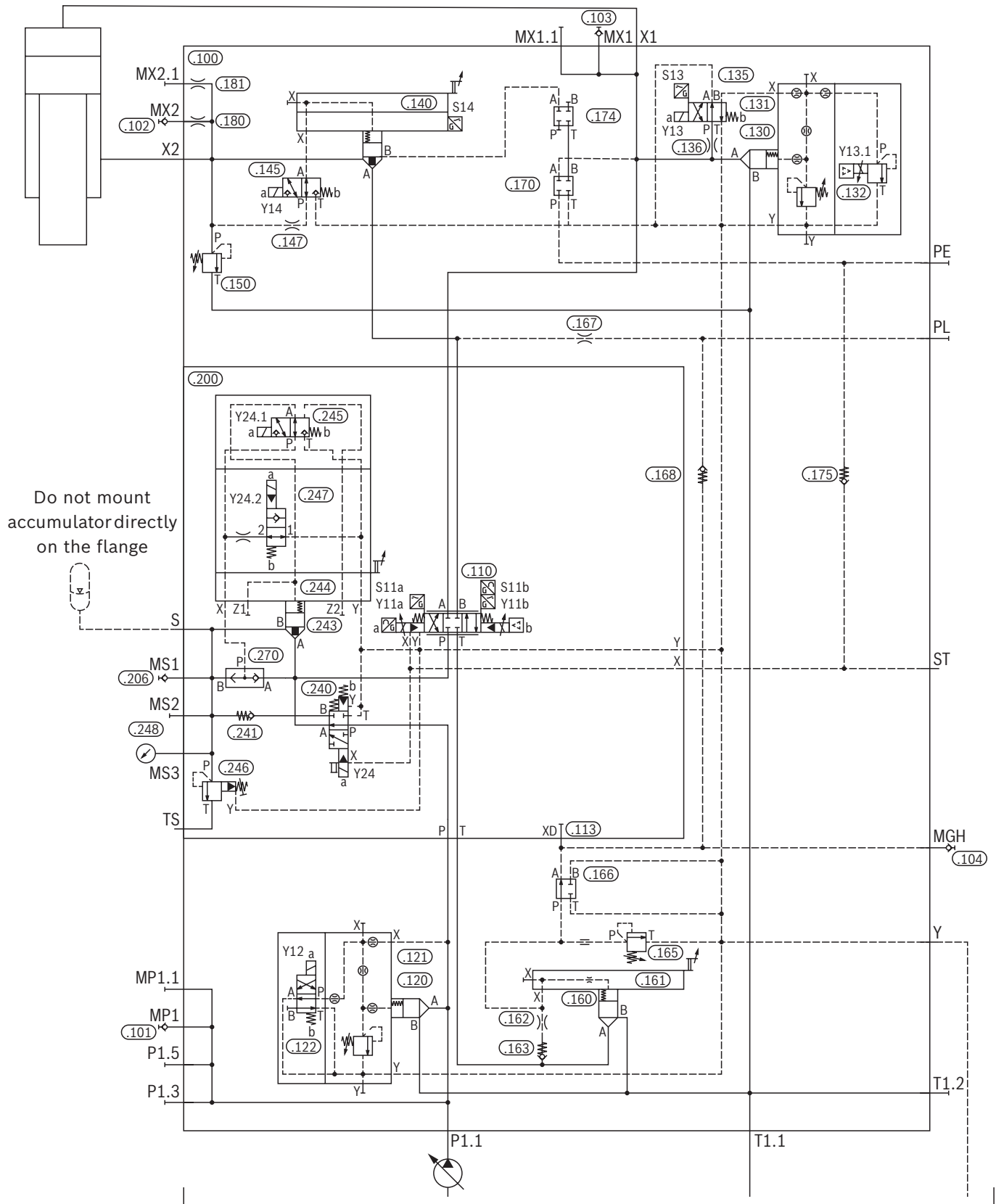

Slide cushion: IH04CS-7X/...2-WE0N-WEH000E-ZN-G24

Option ZN – Item 250

The slide cushion function is always performed when the directional valve item 110 is switched in parallel. The on/off valve item 250 (Y25-ON) controls the connection between piston chamber and annulus chamber continuously during the drawing process and refills the annulus chamber.

This way, cavitation of the annulus chamber is actively prevented. By means of the electric position monitoring S25 it can be monitored whether the basic position is reached.

The pressure reducing valve item 251 serves as maximum pressure adjustment for refilling of the annulus chamber (e.g. 10 bar).

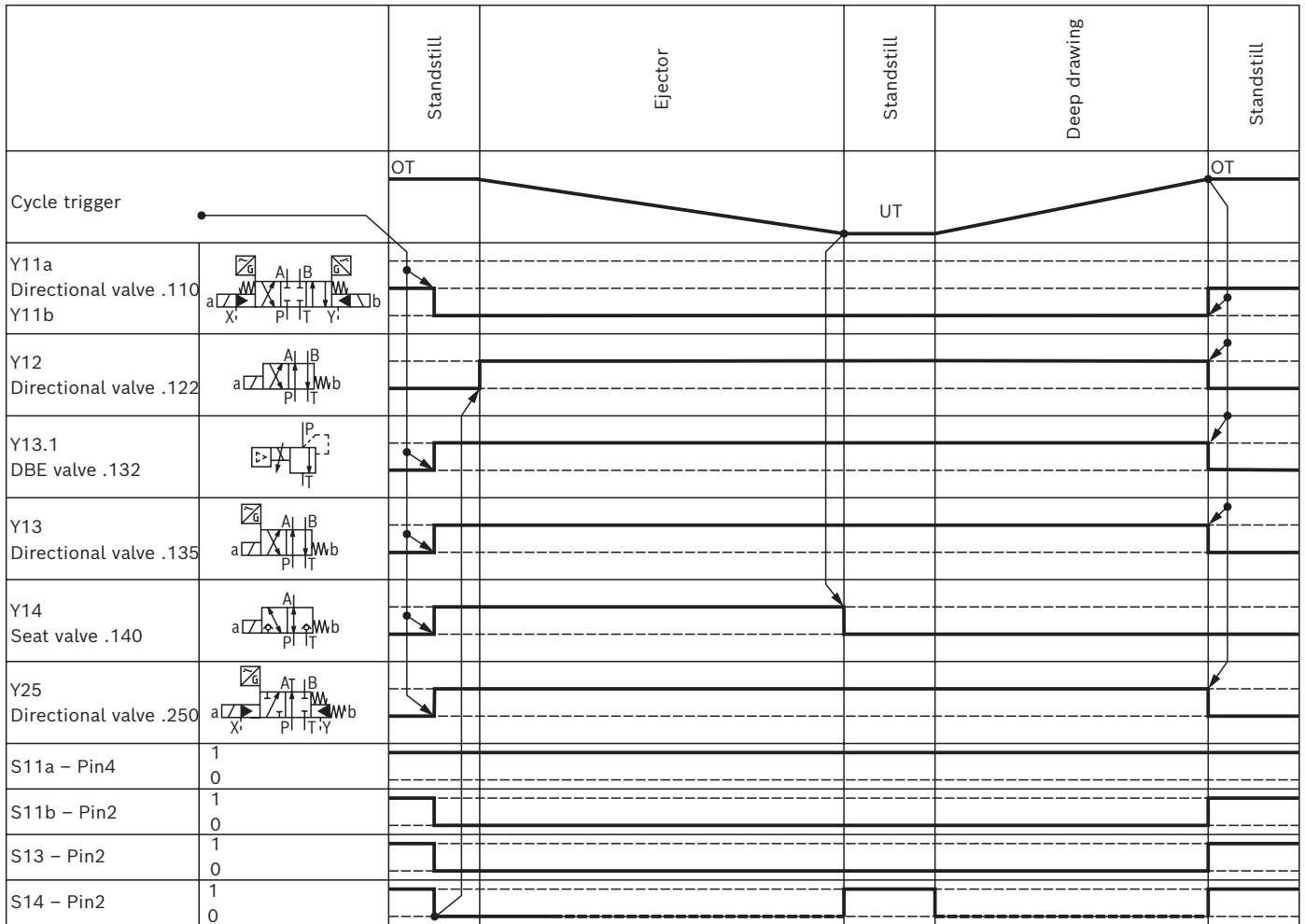

Slide cushion: IH04CS-7X/...2-WEON-WEH000E-ZN-G24

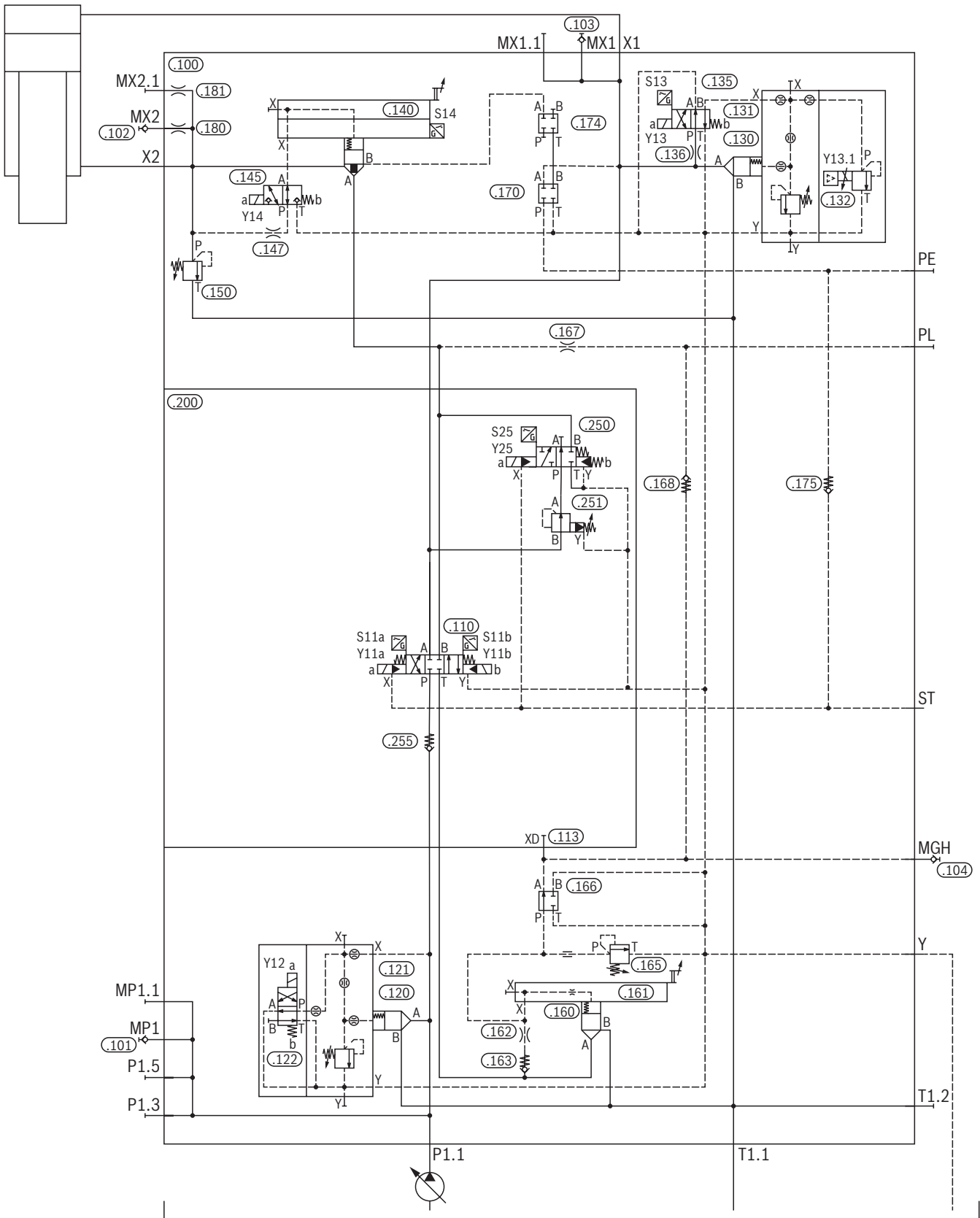

Set-up by own weight with prefill valve (> 10 mm/s): IH04CS-7X/...2-EB1N -WEH000E-NN-G24-002**Option E – Item 120**

The pressure relief valve consisting of the items 120/121 limits the pressure of the motor pump station (hydraulic energy supply). At the pressure relief valve item 121, the maximum operating pressure is set. The proportional pressure relief valve item 122 provides pilot control of the pressure relief valve item 120/121 and determines the system pressure (e.g. press force, decompression):

- ▶ When the set pressure is exceeded, the pressure relief valve item 120/121 will open to the tank.
- ▶ When the set pressure is no longer reached, the pressure relief valve item 120/121 will close.

With a control signal (Y12) of 0V at the proportional pressure relief valve item 122, the pressure relief valve item 120/121 will switch to depressurized circulation.

Option B – Item 130

The pressure relief valve consisting of the items 130/131 limits the pressure on the piston chamber side of the cylinder. At the pressure relief valve item 131, the maximum system pressure is set.

Option 002 – Item 260

The on/off valve item 260 initiates the closing movement by own weight. Set-up is achieved by means of a hold-to-run control device and in creep speed by own weight. Thereby, the oil is sucked in via the prefill valve from the tank into the piston chamber. By means of the position monitoring S26 it is monitored whether the basic position is reached at the end of the closing movement.

The manually adjustable throttle valve item 265 determines the closing speed.

Set-up by own weight with prefill valve (> 10 mm/s): IH04CS-7X/...2-EB1N-WEH000E-NN-G24-002

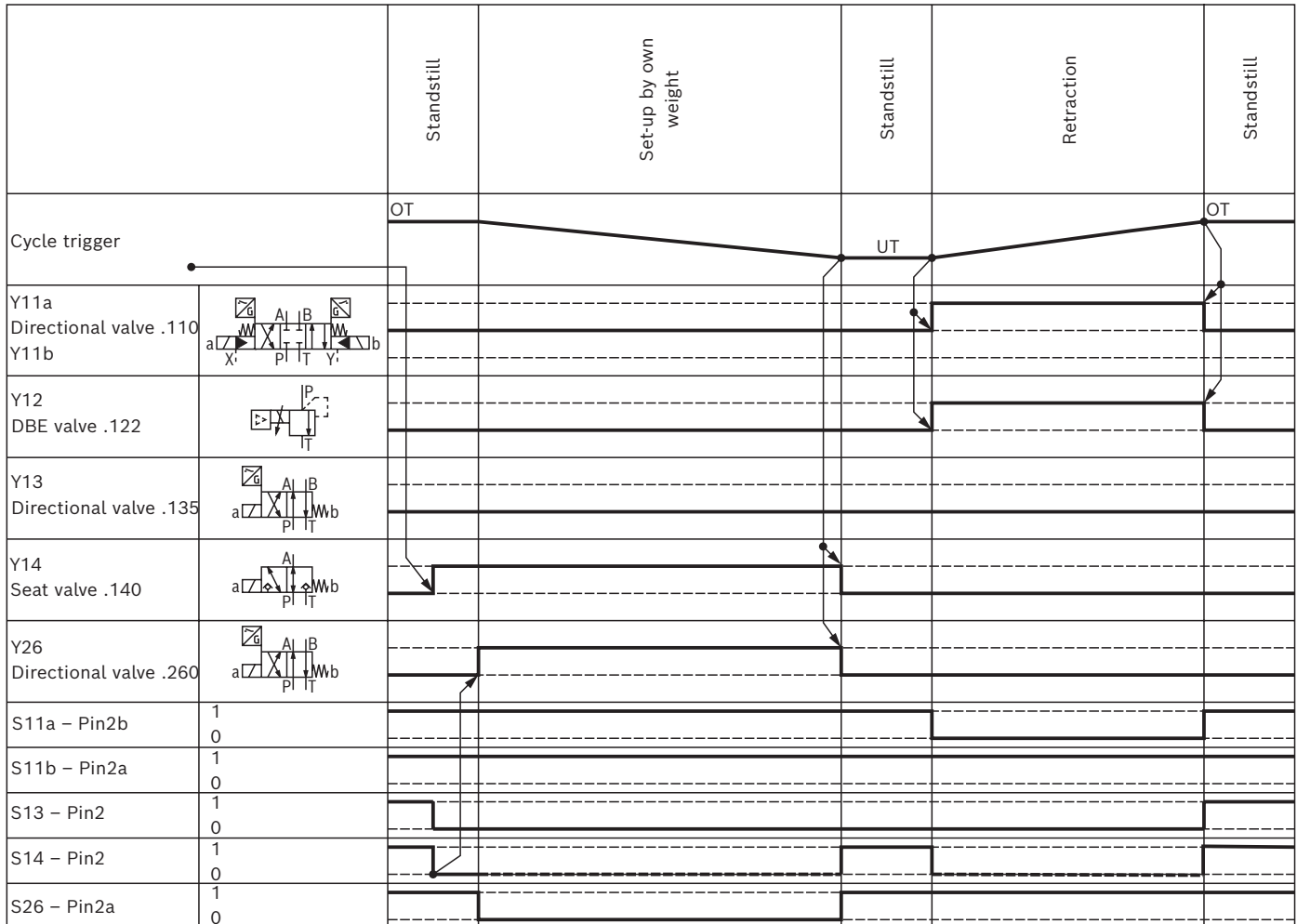

Set-up by own weight with prefill valve (> 10 mm/s): IH04CS-6X/...2-EB1N-WEH000E-NN-G24-002

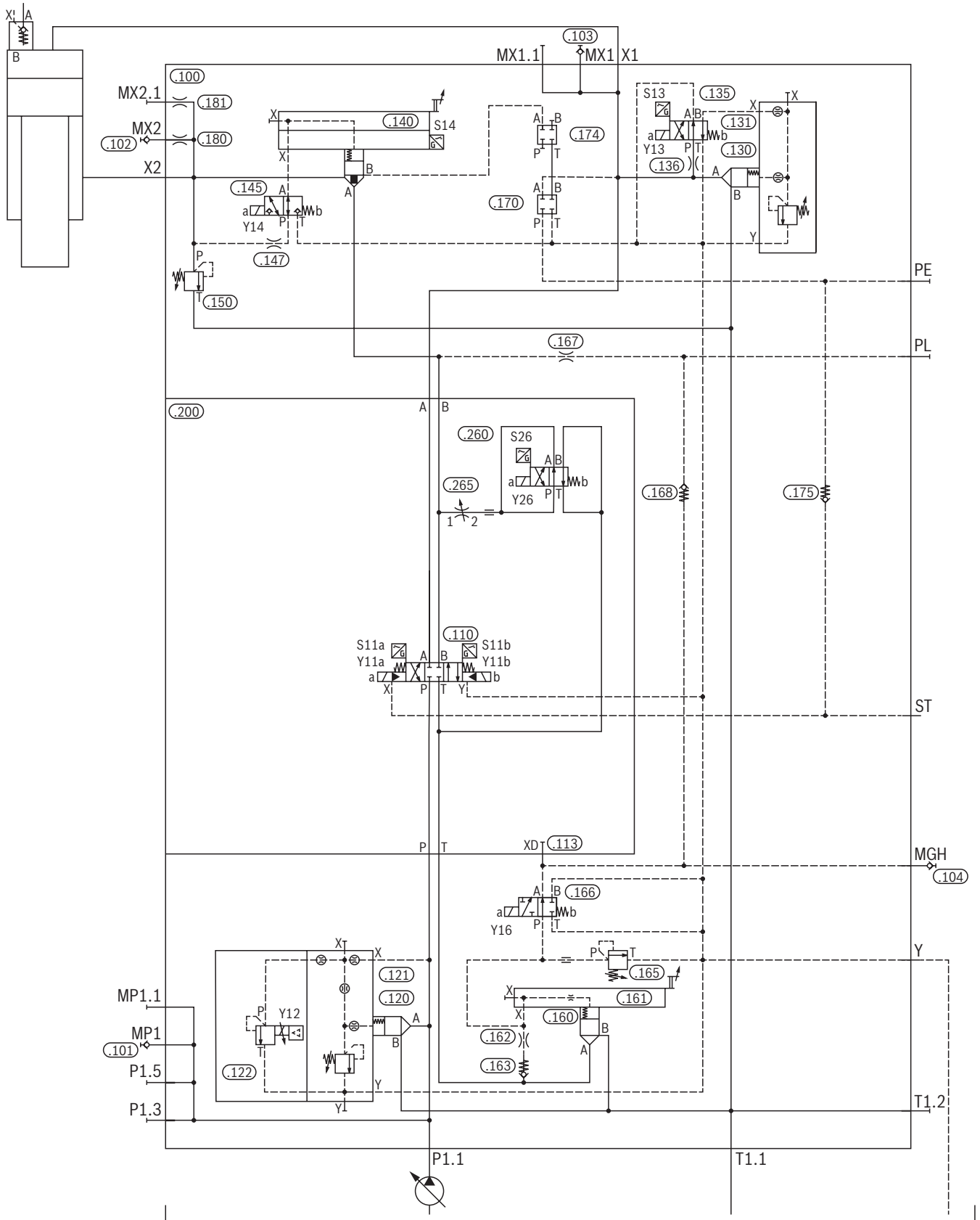

Basic functions according to safety category 1 (ISO 13849 – Pl c):

IH04CN-7X/...1-WU0N-WEH000E-NN-G24

Option WEH000E – Item 110

The movement direction of the cylinder piston is determined by the directional valve item 110:

- ▶ The cylinder piston is extended with the control signal Y11b.
- ▶ The cylinder piston is retracted with the control signal Y11a.

Option U – Item 130

The pressure relief valve consisting of the items 130/131 limits the pressure on the piston chamber side of the cylinder. The on/off valve item 132 with the control signal Y13.1 provides pilot control of the pressure relief valve item 130/131:

- ▶ In basic position, the piston chamber preload DB2 set at the pressure relief valve item 131 takes effect (e.g. during slow retraction with spring tool or decompression).
- ▶ Energization of the solenoid Y13.1 causes the pressure DB1 set at the pressure relief valve item 131 to become effective.

Depressurized circulation in the piston chamber – Item 135

In its basic position, the pressure relief valve item 130/131 switches to depressurized circulation. Energization of the solenoid Y13 causes the pressure stage selected at the on/off valve item 132 to become effective.

Restraint valve in the annulus area – Item 140

The 2-way cartridge valve item 140 holds the cylinder piston in position (see EN ISO 16092-3 section 5.3.7.2). During load holding/retraction, the valve item 140 acts as a check valve and during extension as a switchable isolator valve. By means of the position monitoring S14 it is monitored whether the basic position is reached in every pressing cycle. Item 145 unlocks the 2-way cartridge valve item 140 during extension.

By means of the electric position monitoring S14, opening of the 2-way cartridge valve item 140 at the beginning of rapid traverse is monitored to prevent pressure intensification in the annulus area.

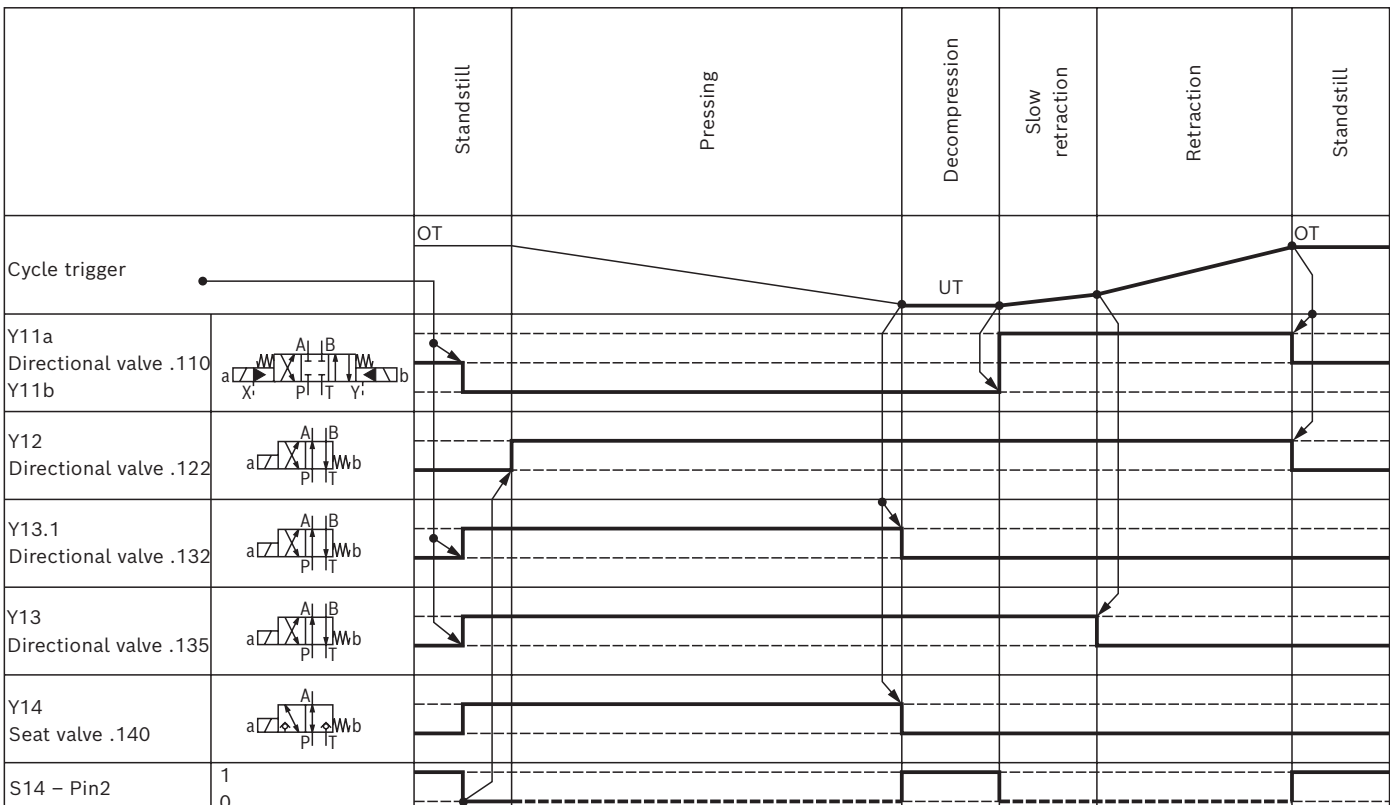

Safe reduced velocity < 10 mm/s (ISO 13849-PL d): IH04CS-7X/...1-WE0D-WEH000E-NN-G24

- ▶ NG10 ... NG35
- ▶ Set-up with reduced velocity (< 10 mm/s) is achieved by means of a hold-to-run control device (ISO 6092-1 section 5.3.2.1 h, ISO 16092-3, section 5.3.2) and fixed orifice (item 172) (factory fitted 0.8 mm).

Option D – Item 170

The seat valve item 174 (Y17) ensures safe opening from the annulus area to the tank. By means of the electric position monitoring S17 it can be monitored whether the basic position is reached.

The movement direction of the cylinder piston is determined by the directional valve item 170. The cylinder piston is extended with the control signal Y17b. Lowering is effected by own weight via a fixed orifice item 172.

The orifice item 172 has to be adjusted to the load holding pressure and the closing spring (at the factory 2 bar) of the slip-in cartridge item 130 so that the closing velocity is limited to a maximum of 10 mm/s. Simultaneously, the piston chamber is filled with oil by the pilot oil circuit or externally, via port PE.

The closing spring of the pressure relief valve item 130/131 limits the pressure on the piston chamber side. Set-up under pressure without velocity limitation is only allowed after contact with the workpiece.

The pressure relief valve consisting of the items 130/131 limits the pressure on the piston chamber side. The proportional pressure relief valve item 132 provides pilot control of the pressure relief valve item 130/131.

The cylinder piston is retracted with the control signal Y17a. The oil supply is always available and is provided by the pilot oil circuit or externally, via port PE.

Safe reduced velocity < 10 mm/s (ISO 13849-PL d): IH04CS-7X/...1-WEOD-WEH000E-NN-G24

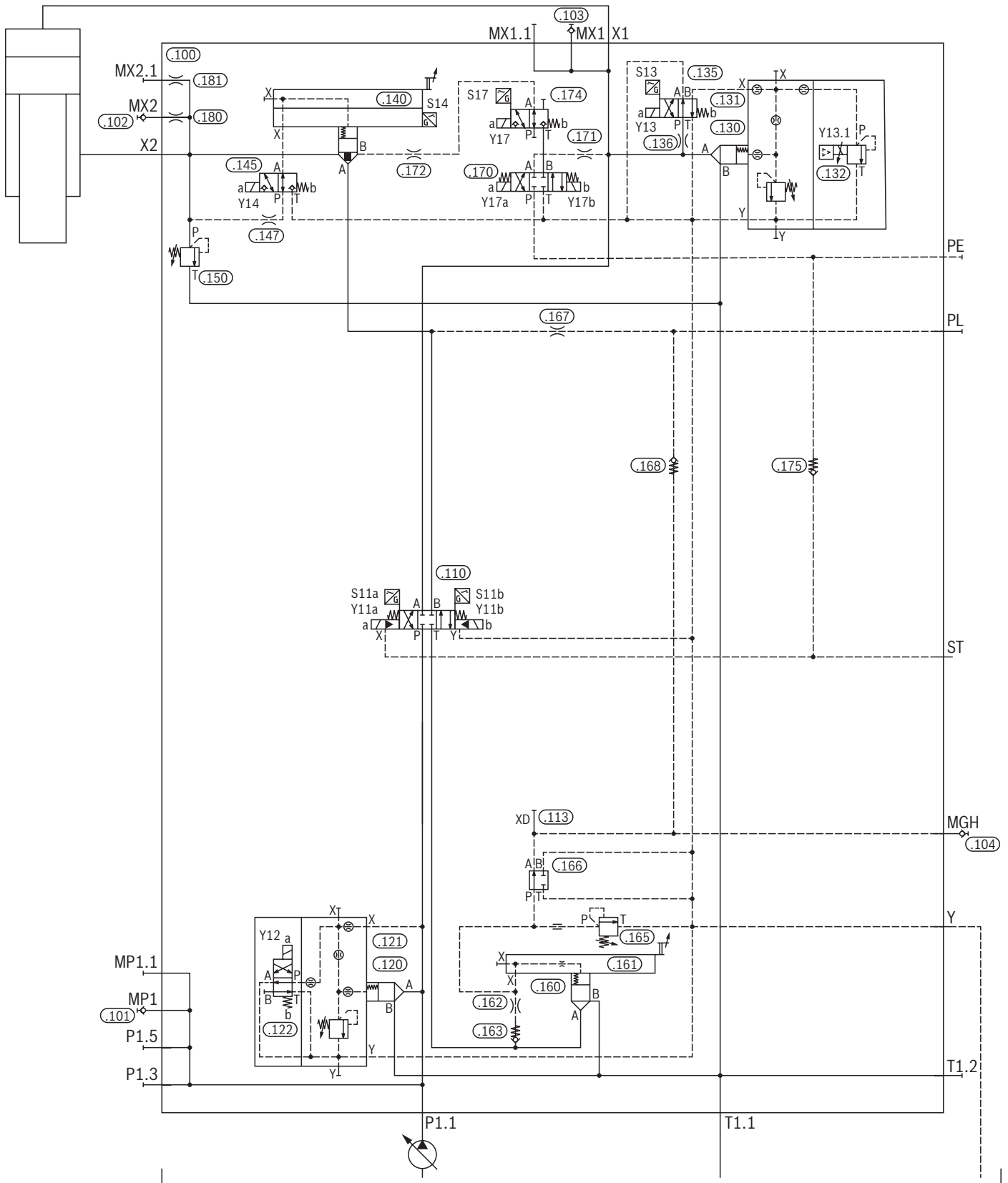

Safe reduced velocity < 10 mm/s (ISO13849-Pl d) and testing of the braking force of the restraint device: IH04CS-7X/...1-WE0P-WEH000E-NN-G24

- ▶ NG10 ... NG35
- ▶ The safe reduced velocity (< 10 mm/s) is achieved by means of a hold-to-run control device (ISO 16092-1 section 5.3.2.1 h, ISO 16092-3, section 5.3.2) and fixed orifice (item 172) (factory fitted 0.8 mm).
- ▶ The braking force of the restraint device is tested in a separate operating mode (with active guarding) and with active restraint device. The pressure in the piston chamber must be checked during testing.

Option P – Item 173

See option D.

The pressure reducing valve item 173, with mechanically fixed setting, is installed in the P-channel and reduces the pressure of the cylinder piston chamber when the restraint device is active.

The resulting force serves as reference braking force.
As standard, a pressure rating of 75 bar is supplied.

Safe reduced velocity < 10 mm/s (ISO 13849-PL d) and testing of the braking force of the restraint device: IH04CS-7X/...1-WE0P-WEH000E-NN-G24

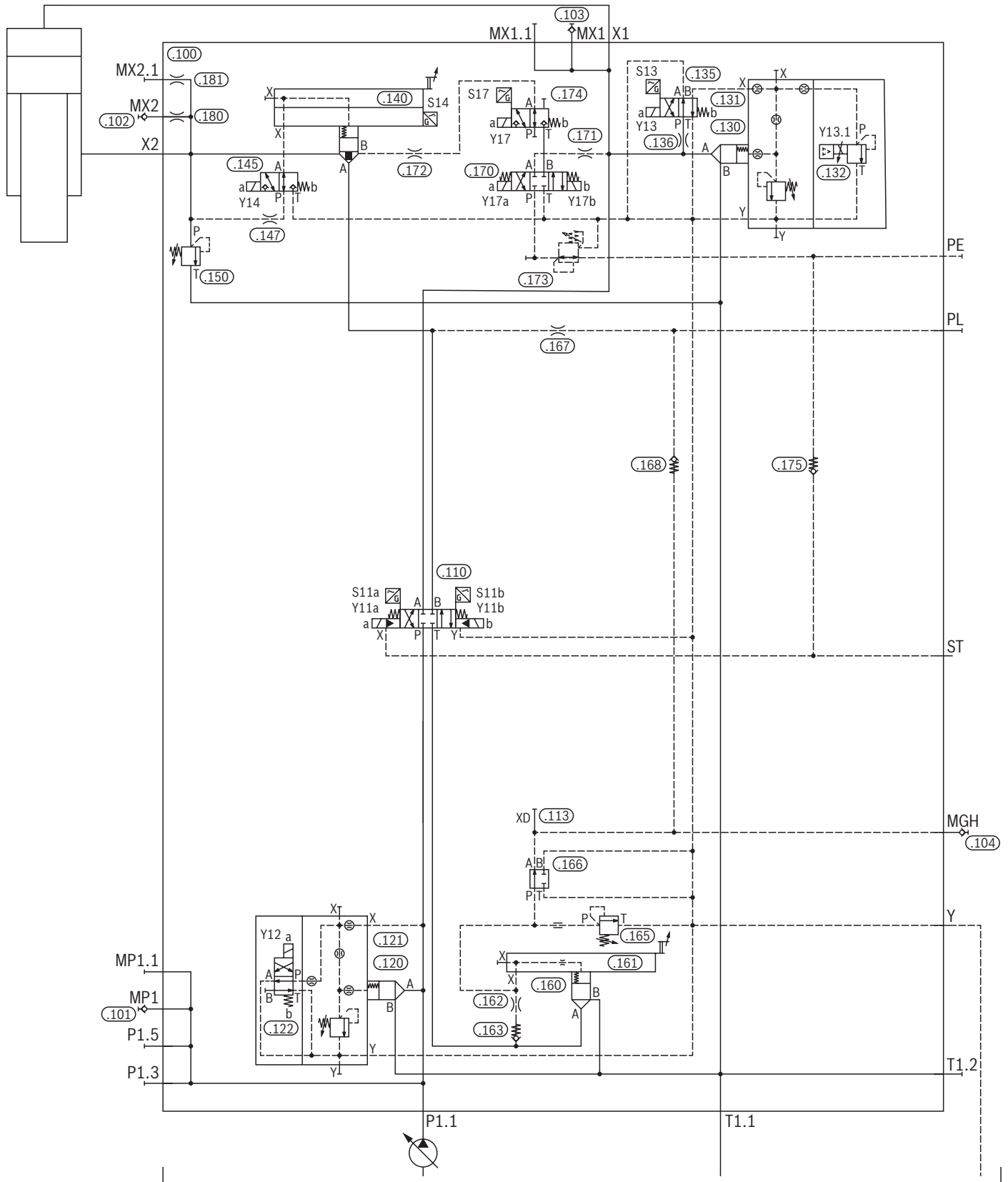

General information**Port sizes**

Port	IH04C-7X/10	IH04C-7X/16	H04C-7X/25	IH04C-7X/32	IH04C-6X/35
P1.1 ... P1.4	G1	2 x SAE 1 ¼-6000	2 x SAE 1 ½-6000	4 x SAE 1 ½-6000	4 x SAE 1 ½-6000
P1.5, ST	G¾	G½	G½	G¾	G¾
P1.6, P1.7	-	-	-	-	2 x DN80
T1.1, T1.2	2 x G1 ½	2 x SAE 2-3000	2 x SAE 2 ½-3000	2 x SAE 3-3000	SAE 5-3000
X1, X11, X12	G1 ¼	SAE 1 ½-6000	SAE 2-6000	DN50	DN80
X2	G1	SAE 1 ¼-6000	SAE 1 ½-6000	DN50	DN80
Y	G½	G½	G½	G1	G1
PE	G¼	G¼	G¼	G¼	G¾
PL	G¼	G¼	G¼	G¼	G¾
HD	G¾	G1	G1 ½	-	-
THD	G1	G1 ¼	G1 ½	-	-
S	G1	SAE 1 ¼-6000	SAE 1 ½-6000	DN50	DN80
TS	G1 ½	SAE 2-3000	SAE 2 ½-3000	SAE 3-3000	SAE 4-3000
LS1	G¼	G¼	G¼	G¼	G¼
MX12	G¾	G¾	G¾	G¾	G½

Connection flanges

Port size	Material no.	Designation	Notice
SAE1 ¼ – 6000 psi	R900012346	FLANSCH SAE11/4 H-38,0 X 6,0	AB02215
SAE1 ½ – 6000 psi	R900015663	FLANSCH SAE11/2 H-48,3 X 8,0	AB02215
SAE2 – 6000 psi	R900012944	FLANSCH SAE2 H-60,3 X 10,0	AB02215
SAE2 – 3000 psi	R900012939	FLANSCH SAE2 S-60,3 X 3,6	AB02215
SAE2 ½ – 3000 psi	R900012336	FLANSCH SAE21/2 S-76,1 X 3,6	AB02215
SAE3 – 3000 psi	R900012940	FLANSCH SAE3 S-88,9 X 3,6	AB02215
SAE5 – 3000 psi	R900012338	FLANSCH SAE5 S-139,7 X 4,0	AB02215
DN50 – PN320	R900049122	FLANSCH FA 50-4 / 76,1 X 12,5	IH04C-7X/32G
DN50 – PN400	R900224176	FLANSCH FA 50-5 / 76,1 X 14,2	IH04C-7X/32S
DN80 – PN320	R900211240	FLANSCH FA 80-4 / 114,3 X 17,5	IH04C-7X/35G
DN80 – PN400	R900761506	FLANSCH FA 80-5 / 133,0 X 25,0	IH04C-7X/35S

Recommended pump versions

IH04CS-6X/...-NN, EN, DN, HN, RN, XN up to IH04CS-6X/35

Pump version	Data sheet	Features
A4VSO...LR2	92050	With mechanical power limitation
A4VSO...LR2G	92064	With mechanical power limitation and remote-controlled pressure cut off ¹⁾
A4VSO...LR2D		With mechanical power limitation and manual pressure cut off
A4VSO...LR2N	Up to 350 bar	With mechanical power limitation and hydraulic stroke adjustment, proportional ²⁾
A4VSO...LR2NT	up to 355 ccm	With mechanical power limitation and hydraulic stroke adjustment with integrated proportional valve ³⁾
A4VSO...HS5(P) ⁴⁾	92050	Power, pressure and flow control with servo valve
A4VSO...HS5(P)V ⁵⁾	92076	Power, pressure and flow control with servo valve and with internal set pressure supply
A4VSO...HS5(P)M		Power, pressure and flow control with servo valve and for use under liquid
A4VSO...HS5E(P) ⁴⁾	Up to 350 bar	Power, pressure and flow control with servo valve and digital on-board electronics
A4VSO...HS5E(P)V ⁵⁾	up to 355 ccm	Power, pressure and flow control with servo valve, digital on-board electronics and internal set pressure supply
A15VSO...LR	92800	With mechanical power limitation
A15VSO...LRDRE2...A ⁶⁾	92801	With mechanical power limitation and manual pressure cut off
A15VSO...LRDRE2...B ⁷⁾		With mechanical power limitation and manual pressure cut off
A15VSO...LRGRE2...A ⁶⁾	Up to 350 bar	With mechanical power limitation and remote-controlled pressure cut off ¹⁾
A15VSO...LRGRE2...B ⁷⁾	up to 280 ccm	With mechanical power limitation and remote-controlled pressure cut off ¹⁾
SYHDFED ⁵⁾	30030 Up to 280 bar up to 140 ccm	Power, pressure and flow control with field bus interface and speed variability ⁸⁾
SY(H)DFEF ⁵⁾	30035 up to 350 bar up to 355 ccm	Power, pressure and flow control with field bus interface
HS5E(n) ⁵⁾	92050 up to 350(450) bar up to 1000 ccm	Power, pressure and flow control with field bus interface and speed variability ⁸⁾
PGH	10227	Fixed displacement with speed variability ⁸⁾ Up to 350 bar and up to 250 ccm

1) Separate order DBETE (data sheet 29162)

2) Separate order 3DREPE6A-2X/45...A1

3) Only suitable for motor design B35

4) External pilot oil supply required

5) Internal pilot oil supply for pressure control above 20 bar, with preload block below 20 bar

6) Electric stroke adjustment via integrated oil-resistant proportional valve. Internal pilot oil supply for an operating pressure of more than 20 bar.

7) Electric stroke adjustment via integrated oil-resistant proportional valve. External pilot oil supply from 30 to 50 bar required for an operating pressure of less than 20 bar.

8) Asynchronous motor MOT-FC - DCCS10601-2 and frequency converter EFC5610 - DCCS-41044-11

Recommended pump versions

Pump versions for IH04CS-7X/...TEM...E-LN

Pump version	Data sheet	Features
A4VSO...LR2S	92064	350 bar / up to 355 ccm
A15VSO...LRDRS0/10 A15VSO...LRDRS0/11	92800/ 92801	350 bar / up to 280 ccm
A10VSO...DFLR/31 ¹⁾	92711	280 bar / up to 140 ccm
A10VSO...LA...DS/32 ¹⁾	92714	280 bar / up to 180 ccm

The pumps are equipped with mechanical power limitation, load-sensing and remote-controlled pressure cut off.

¹⁾ With DFLR and LADS controllers, remove the orifice in the X adapter at the pump (flow controller).

Pump versions for IH04CS-7X/...SN – up to IH04CS-6X/35

Pump version	Data sheet	Features
A4VSO...DFR1 A4VSO...DP	92050/ 92060	350 bar / up to 355 ccm
A15VSO...DP/10 A15VSO...DP/11	92800/ 92801	350 bar / up to 280 ccm
A10VSO...DFR1/31	92711	280 bar / up to 140 ccm
A10VSO...DRS/32	92714	280 bar / up to 180 ccm

For the pressure remote control, separate order DBETE (data sheet 29162).



Notice:

These pump versions can be used for pressure holding on the piston chamber side without extension module **XN**.

Further information

- ▶ Mating connectors and cable sets for valves and sensors Data sheet 08006
- ▶ On/off valves with spool position monitoring Data sheet 24830
- ▶ 4/3 proportional directional valves, direct operated, with integrated control electronics, electrical position feedback and spool position monitoring, with test certificate type 4WREEM Data sheet 29064
- ▶ 4/2-, 4/3-proportional directional valve, pilot-operated, without electr. position feedback, without/with integr. electronics (OBE), with spool position indicator Data sheet 29117
- ▶ 2-way cartridge valves with spool position monitoring Data sheet 21015
- ▶ Proportional pressure relief valve Data sheet 29166
- ▶ Pressure relief valve, direct operated Data sheet 25402
- ▶ Power regulators LR2, LR3 and LR2N for variable displacement pump A4VSO Data sheet 92064
- ▶ Axial piston variable displacement pumps A15VSO, A15VLO, series 10 Data sheet 92800
- ▶ Axial piston variable displacement pump A10VO, series 52 and 53 Data sheet 92703
- ▶ Axial piston variable displacement pump A10VSO Data sheet 92714
- ▶ Control and adjustment systems HM, HS, HS5 and EO Data sheet 92076
- ▶ Digital control electronics for axial piston pumps Data sheet 30237
- ▶ Controllers DR, DP, FR and DFR Data sheet 92060

Bosch Rexroth AG
Industrial Hydraulics
Zum Eisengießber 1
97816 Lohr am Main, Germany
Phone +49 (0) 93 52/40 30 20
my.support@boschrexroth.de
www.boschrexroth.de

© This document, as well as the data, specifications and other information set forth in it, are the exclusive property of Bosch Rexroth AG. It may not be reproduced or given to third parties without consent of Bosch Rexroth AG. The data specified above only serve to describe the product. No statements concerning a certain condition or suitability for a certain application can be derived from our information. The information given does not release the user from the obligation of own judgment and verification. It must be remembered that our products are subject to a natural process of wear and aging.