

Self-contained axis

Type CytroMotion



- ▶ Component series 1X
- ▶ Maximum force generated by pressure up to 110 kN
- ▶ Maximum travel velocity 740 mm/s
- ▶ Maximum stroke length 800 mm
- ▶ Closed system

Features

- ▶ Ready to install, easy installation (purely electrical connection)
- ▶ For applications with a closed control loop
- ▶ Compact design
- ▶ Installation independent of position
- ▶ Flexible set-up
- ▶ Maintenance-free
- ▶ Robust in use
- ▶ Optionally connectable reduced-force rapid traverse (regenerative mode)
- ▶ Operation with standard converter technology

Contents

Features	1
Ordering code	2
Function	3, 4
Technical data	5, 6
Performance range	7, 8
Dimensions	9, 10
Electrical connections	11
Accessories	12
Further information	12

Ordering code

01	02	03	04	05	06	07	08	09	10	11	12	13	14
CYTROMOTION	-	1X	/	H		/	/	/	/	P	B	/	X

01	CytroMotion	CYTROMOTION
----	-------------	--------------------

02	Component series 10 ... 19 (10 ... 19: unchanged installation and connection dimensions)	1X
----	--	-----------

Cylinder design

03	Mill type	H
----	-----------	----------

Cylinder function

04	Differential cylinder	D
	Differential cylinder with position measurement system	S

Cylinder mounting types

05	Round flange at head	F
----	----------------------	----------

Piston \varnothing (\varnothing AL) ²⁾

06	40 mm	040
	50 mm	050
	63 mm	063
	80 mm	080

Piston rod \varnothing (\varnothing MM) ²⁾

07	28 mm	028
	36 mm	036
	45 mm	045
	56 mm	056

08	Stroke length 0050 ... 0800 in mm ¹⁾	
----	---	--

09	Parallel orientation	P
----	----------------------	----------

10	Frame size 2	B
----	--------------	----------

Geometric displacement volume pump V_g

11	3.6 cm ³	C
	5.2 cm ³	E
	7.3 cm ³	G
	9.3 cm ³	I
	10.4 cm ³	J
	11.4 cm ³	K

Rated power

12	3.5 kW	C
	4.8 kW	D
	6.2 kW	F

Hydraulic circuit

13	Standard	S
	Reduced-force rapid traverse (regenerative mode)	R

Cover

14	Standard	S
	Without	X

1) Preferably in 50 mm steps

2) For possible combinations, see table on page 7

Function

The CytroMotion is a compact, energy-efficient self-sustaining axis that converts electrical energy into a precise, controllable movement of a hydraulic cylinder. The pre-tested overall system can be installed easily and independently of position, the integration is purely electric.

Forces up to 110 kN can be realized. Optionally, a rapid traverse with reduced force can be switched on in order to increase the speed of the cylinder during extension up to 740 mm/s (regenerative mode, version "R").

The CytroMotion basically consists of a synchronous motor with a rotary encoder (1), a 4Q-capable and low-noise internal gear pump (2), a cylinder unit (3), a compensator for the compensation of differential volume (4), a valve block (5) and an optional position measurement system (6).

Motor-pump group

The motor-pump group provides hydraulic power as required.

Cylinder unit / actuator

The cylinder unit of the compact axis converts flow and pressure into a linear movement with force.

Compensator (low-pressure accumulator)

The servo-hydraulic actuator is a hydraulically closed system. The compensator is used to receive differential

volume of the retracting and extending piston rod and also temperature variations.

Valve block

By switching the 2/2 directional seat valves (VA, VB, VE and VR) used, various functions such as retraction and extension of the cylinder and holding the cylinder are implemented, and the rapid traverse is optionally switched on (see CytroMotion operation on page 4).

The pressure transducers SA, SB and SK used monitor the working pressures and the compensator pressure. In addition, the pressures are limited by the pressure relief valves used.

Position measurement system

(optional, cylinder version "S")

The piston position is detected by an installed absolute position measurement system.



Notice:

- Generator operation: External force effect on the cylinder may drive the motor/pump group. Consequently, the motor acts as a generator and generates electrical energy. This energy must be dissipated or stored by suitable measures such as a braking resistor or a feed-back unit.
- Retraction under load: If the retraction of the self-contained axis is to take place during the process under load in the direction of movement, please contact Bosch Rexroth.

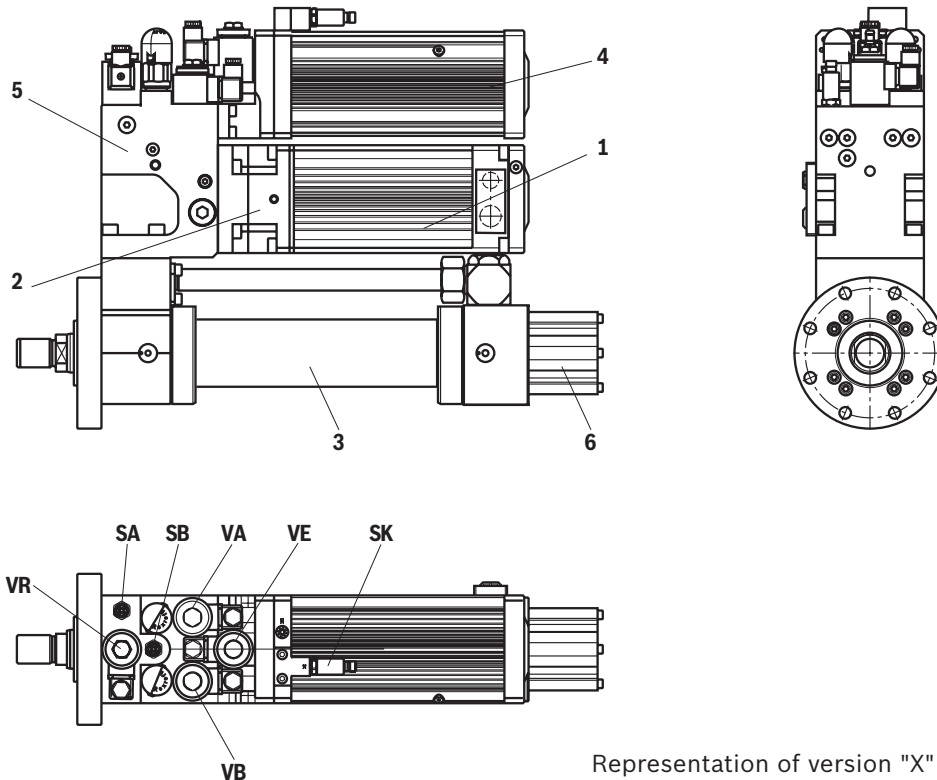

Representation of version "X" (without cover)

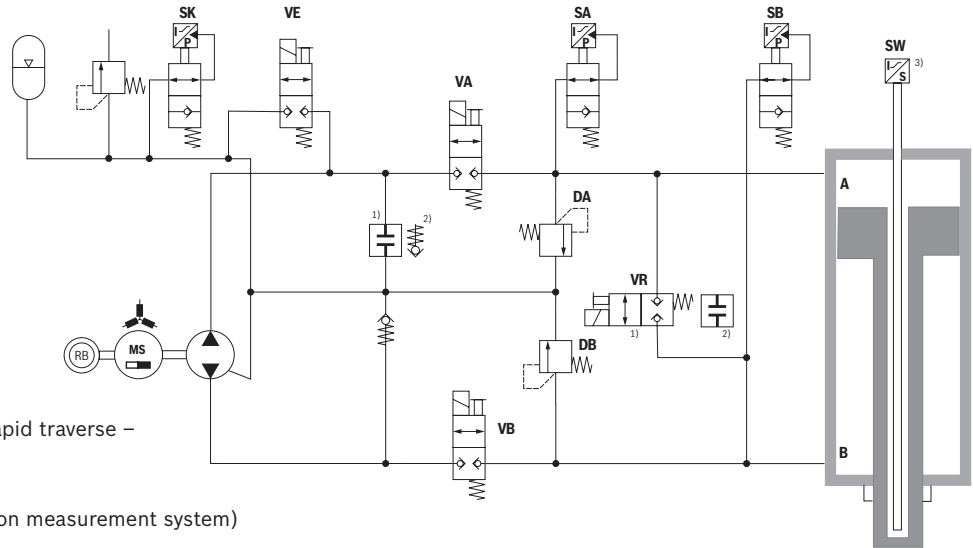
Function: Hydraulic circuit diagram

- 1) Fitting with version "R" (reduced-force rapid traverse – regenerative mode).
- 2) Fitting with version "S" (standard)
- 3) Only for cylinder version "S" (with position measurement system)

Valve	VA	VB	VE	VR	Motor rotation direction ³⁾
Basic position	– ¹⁾	–	–	–	–
Force traverse, extending	+ ²⁾	+	–	–	right (clockwise)
Extending reduced-force rapid traverse (regenerative mode)	+	–	–	+	right (clockwise)
Retraction	+	+	+	–	left (anti-clockwise)
Hold force generated by pressure	–	+	–	–	–
Hold traction force	+	–	–	–	–

1) - → 2/2 directional seat valve, without current

2) + → 2/2 directional seat valve, with current

3) Looking onto the drive shaft (piston rod of the CytroMotion)

CytrMotion operation**Basic position:**

The motor is off / de-energized and all valves are without current. The pressure medium in the cylinder chambers A and B is blocked by the 2/2 directional seat valves.

Force traverse, extending:

Motor direction of rotation clockwise, the motor speed according to the speed requirement on the cylinder. The 2/2 directional seat valves VA and VB are switched/energized. The pressure medium is conveyed from the rod side of the cylinder B via the 2/2 directional seat valves VB and VA into the piston sides of the cylinder A. The additional differential volume is "sucked" out of the compensator via a check valve. The cylinder extends.

Reduced-force rapid traverse extension

(regenerative mode):

Only possible with version "R".

Motor direction of rotation clockwise, the motor speed according to the speed requirement on the cylinder. The 2/2 directional seat valves VA and VR are switched/energized. The pressure medium is conveyed by the pump via the 2/2 directional seat valve VA into the piston side A of the cylinder. The displacement additionally conveys the pressure medium from the rod side B via the 2/2 directional seat valve VR into the piston side A. The additional differential volume is "sucked" out of the compensator via a check valve. Thus, the extension speed can be nearly doubled compared to the "extension of the force traverse".

As a result of the area ratios of the differential cylinder, the force generated by pressure is reduced by about half. (For the gear ratio, see page 7)

The cylinder extends in a reduced-force rapid traverse.

Retraction:

Motor direction of rotation counterclockwise, the motor speed according to the speed requirement on the cylinder. The 2/2 directional seat valves VA, VB and VE are switched/energized. The pressure medium is conveyed from the piston side of the cylinder A via the 2/2 directional seat valves VA and VB into the rod sides of the cylinder B. The differential volume from the piston side A is conveyed via the valve VE into the compensator. The cylinder retracts.

Hold force generated by pressure:

The motor is off / de-energized.

The 2/2 directional seat valve VB is switched/energized in order to relieve the rod side of the cylinder B. The pressure in the piston side of the cylinder A is blocked by the closed 2/2 directional seat valve VA. The force generated by pressure is held.

Hold traction force:

The motor is off / de-energized.

The 2/2 directional seat valve VA is switched/energized in order to relieve the piston side of the cylinder A. The pressure in the rod side of the cylinder B is blocked by the closed 2/2 directional seat valve VB. The traction force is held.

Technical data

(For applications outside these values, please consult us!)

General	
Design	Closed system
Actuation	Electric
Type of connection	Round flange at head
Installation position	Any
Ambient temperature range operation	°C 5 ... +40
Weight	kg 60 ... 130 (configuration dependent)
Condensation	Not admissible
Maintenance interval	>10m load cycles
Protection class according to EN 60529	IP65
MTTFD values ¹⁾ according to EN ISO 13849	Years 100
Performance level ²⁾ according to EN ISO 13849-1	Safety function SSC category 3 up to PL e Safety function PUS category 3 up to PL e

¹⁾ Applies to the valve combination of the self-contained axis²⁾ The valve combination of the self-contained axis corresponds to the evaluation of the specified performance level, only when using suitable control technology. Only for cylinder function with position measurement system "S". Refer to operating instructions 62290-B, chapter 5.1.8

Hydraulic	
Nominal pressure	bar 225
Admissible pressure peaks	bar 250
Compensator pressure	bar 2.0 ... 4.0
Maximum compensator pressure	bar 13
Oil volume	l 2 ... 10 (configuration dependent)
Hydraulic fluid	HLP 46 (Data Sheet 90220)
Hydraulic fluid temperature range (flown-through)	°C -20 ... +75

Internal gear pump							
Pump version		C	E	G	I	J	K
Geometric displacement pump per rotation	cm ³	3.6	5.2	7.3	9.3	10.4	11.4
Speed	1/min	0 ... 2400					

Synchronous motor				
Motor version		C	D	F
Nominal power	kW	3.5	4.8	6.2
Mains voltage (input voltage for converter)	V	400 ... 480		
Maximum link voltage	V DC	560 ... 680		
Voltage tolerance (nominal voltage)	%	+/- 10		
Rated current	A	7.6	10.5	13.8
Maximum admissible current	A	19	26.3	34.5
Rated speed	1/min	2400		
Nominal frequency	Hz	200		
Rated torque	Nm	13.8	19.3	24.8
Maximum torque	Nm	34.5	48.3	62
Resistance at 20°C	Ω	2.66	1.8	1.4
Number of poles		10		
D - impedance PH - PH	mH	18	12	10
Q - impedance PH - PH	mH	28	20	16
Back EMF	V ms/rpm	137 / 1000		

Technical data

(For applications outside these values, please consult us!)

2/2-way screw-in seat valves			
Voltage type		Direct voltage	
Nominal voltage	V	24	
Rated current	A	1.36	
Nominal power	W	32.7	
Duty cycle (ED)	%	100	
Switching time according to ISO 6403	▶ ON	ms	50 ... 60
	▶ OFF	ms	50 ... 60

Position measurement system			
Electrical connection	▶ Type of connection	ms	1 x M16 connector (7-pole)
	▶ Power consumption	W	1.2 typical
SSI	▶ Interface		SSI 24 bit (RS-485/RS-422)
	▶ Resolution	μm	0.5
	▶ Direction of measurement		Synchronous forward
	▶ Data format		Gray

Pressure transducer			
Supply voltage	▶ Nominal voltage	VDC	24
	▶ Lower limit value (U_S)	VDC	18
	▶ Upper limit value (U_S)	VDC	36 ³⁾
	▶ Maximum admissible residual ripple	V _{SS}	2.5 (40 ... 400 Hz)
Current consumption		I _{max}	≤ 12 mA (with voltage output)
Protection class			III
Isolation resistance		MΩ	>100 (500 VDC)
Measurement range		bar	10 250
Overload protection		bar	20 500
Bursting pressure		bar	200 1000

Output			
Output signal and admissible load R_A	▶ Current (I_{Sig})	mA	4 ... 20; $R_A = (U_S - 8.5 \text{ V}) / 0.0215 \text{ A}$ with R_A in Ω and U_S in V
Setting time (10 to 90%)		ms	< 1
Characteristic curve deviation (corresponds to the measuring deviation according to DIN EN 61298-2)		%	< 0.5 (related to the complete measurement range, including non-linearity, hysteresis, zero point and end value deviation)
Temperature coefficient (TC) for zero point and range	▶ Within nominal temperature range	% / 10 K	< 0.1
	▶ Outside nominal temperature range	% / 10 K	< 0.2
Non-repeatability		%	±0.05 ⁴⁾
Long-term drift (1 year) under reference conditions		%	±0.1

3) With cCULus max. 30 VDC

4) Related to the nominal temperature range

Performance range

Effective cylinder area, force generated by pressure and travel velocity with reduced rapid traverse (version "R")

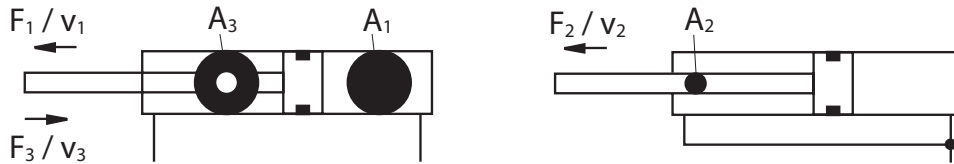

Area ratio and cylinder force									
Piston	Piston rod	Power class	Area ratio	Areas			Force at 225 bar ³⁾		
				Piston	Rod	Ring	Pressure	Diff.	Pulling
ØAL mm	ØMM mm	kN	ϕ A_1/A_3	A_1 cm ²	A_2 cm ²	A_3 cm ²	F_1 kN	F_2 kN	F_3 kN
40	28	25	1.96	12.56	6.16	6.40	28.26	13.86	14.4
50	36	45	2.08	19.63	10.18	9.45	44.19	22.86	21.29
63	45	70	2.04	31.17	15.90	15.27	70.11	35.78	34.34
80	56	110	1.96	50.26	24.63	25.63	113.09	55.4	57.69

³⁾ Theoretical static cylinder force (without consideration of the efficiency and admissible load for attachment parts such as swivel heads, plates, or valves, etc.)

Thermal load

at maximum force (working pressure 225 bar) and high cyclic load

Thermal load			
Geometric displacement [cm ³]	Rated power [kW]		
	3.5	4.8	6.2
3.6	o	-	
5.2		o	o
7.3		+	+
9.3		++	+
10.4			++
11.4			++

- Low thermal load
- o Mean thermal load
- + High thermal load
- ++ Very high thermal load

The thermal load increases with increasing force (with increasing working pressure). The combination of synchronous motor and internal gear pump also influences the thermal load (see table "Thermal load"). High loads over a certain cycle time can lead to an unacceptably high temperature rise and thus damage the motor or the hydraulic fluid.

For system designs with high cycle load, please contact Bosch Rexroth.

Performance range

Nominal maximum velocity [mm/sec]

at 2400 rpm

Extending force traverse v_1				
Geometric displacement [cm ³]	Cylinder size			
	040/028	050/036	063/045	080/056
3.6	115	73	46	29
5.2	166	106	67	41
7.3	232	149	94	58
9.3	296	190	119	74
10.4	331	212	133	83
11.4	363	232	146	91

Extending reduced-force rapid traverse v_2 (regenerative mode)				
Geometric displacement [cm ³]	Cylinder size			
	040/028	050/036	063/045	080/056
3.6	225	152	94	56
5.2	325	220	136	81
7.3	456	309	191	114
9.3	581	394	244	145
10.4	650	440	272	162
11.4	713	483	299	178

Retracting v_3				
Geometric displacement [cm ³]	Cylinder size			
	040/028	050/036	063/045	080/056
3.6	234	141	91	58
5.2	338	204	131	84
7.3	474	287	184	119
9.3	604	365	234	151
10.4	675	409	262	169
11.4	740	448	287	185

Notice:

As the pressure increases, the delivery volume and thus the maximum velocity are reduced.
Usually, high travel velocities with simultaneous high pressure are not encountered.

Dimensions
(dimensions in mm)

Representation version "D" differential cylinder without position measurement system and "S" with cover

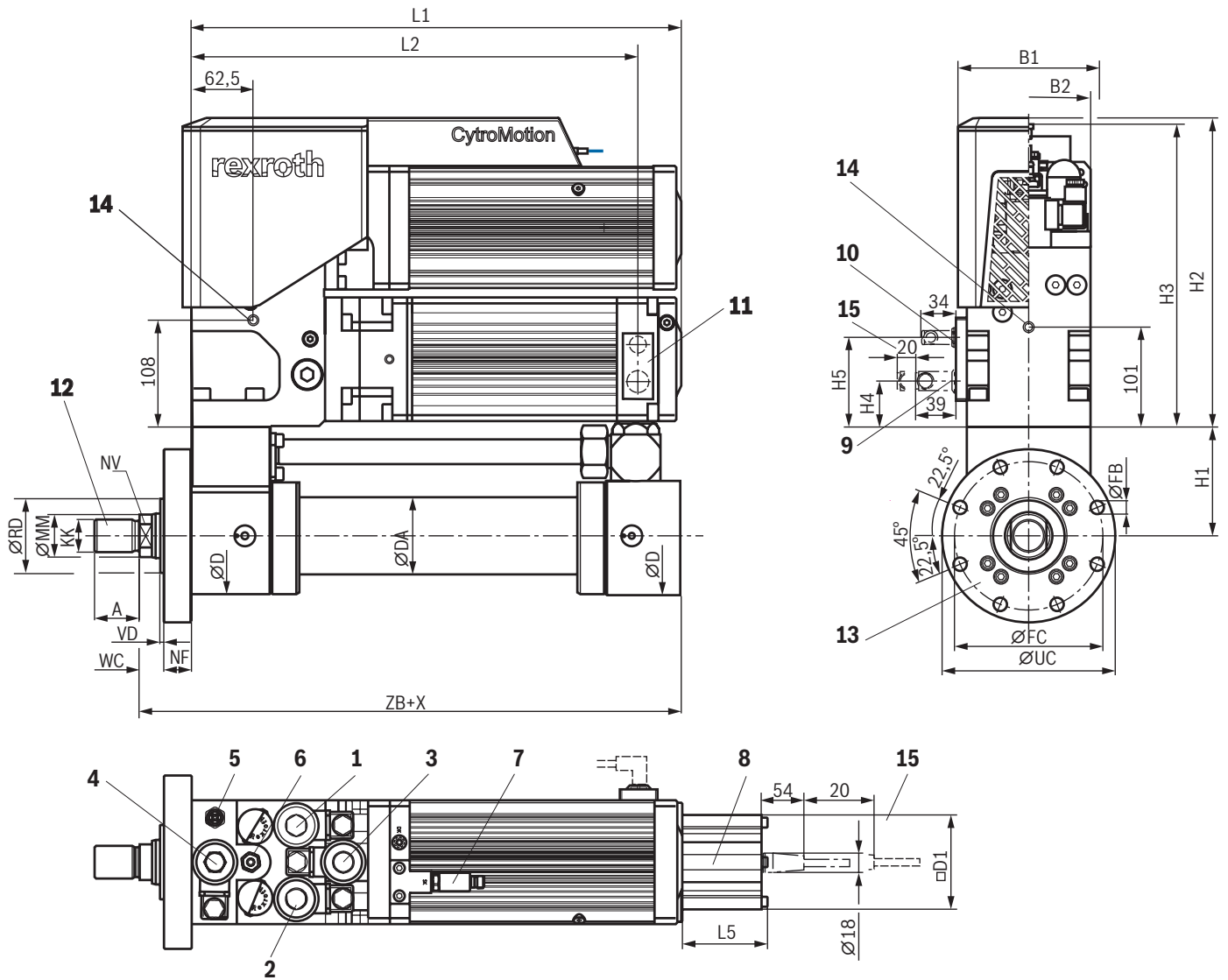

Representation of the "S" version of the differential cylinder with position measurement system, reduced-force rapid traverse "R" and without cover "X"

Item explanations and mounting screws see 10.

Notice:
The dimensions are nominal dimensions which are subject to tolerances.

Dimensions:

(dimensions in mm)

ØAL	ØMM	KK	A	NV	ØD	ØDA	X +2	L5 2)	D1 max	ØRD	WC ±2	VD	NF js13	ZB max	ØFB H13	ØFC js13	ØUC -1
40 1)	28	M20x1.5	28	22	88	52	Stroke	166	80	52	22	4	25	239	11	115	138
50	36	M27x2	36	27/30	102	62	Stroke	166	96	63	22	4	25	254	13.5	132	155
63	45	M33x2	45	32/30	120	78	Stroke	166	96	75	25	4	28	299	13.5	150	175
80	56	M42x2	56	41/46	145	95	Stroke	166	96	90	28	4	32	332.5	17.5	180	210

L1 3)	L2	B1	B2 3)	H1	H2	H3 3)	H4	H5
580	499	143	125 4)	422.5	312.5	290 4)	46.5	90.5
619	499	143	180	422.5	312.5	345	46.5	90.5
779	499	143	180	422.5	312.5	345	46.5	90.5
779	499	143	180	422.5	312.5	345	46.5	90.5

1) Piston diameter not standardized

2) Only for version "S" (with position measurement system)

3) Maximum dimension (largest compensator with max. stroke 800 mm) Configuration-based dimensions see configurator CytoMotion

Item explanations

- | | |
|---|---|
| <ul style="list-style-type: none"> 1 2/2 directional seat valves VA 2 2/2 directional seat valves VB 3 2/2 directional seat valves VE 4 2/2 directional seat valves VR (only for version "R") 5 Pressure transducer SA 6 Pressure transducer SB 7 Pressure transducer SK 8 Position measurement system SW | <ul style="list-style-type: none"> 9 Motor connection 10 Resolver connection and motor temperature 11 Name plate 12 Piston rod end: Thread for the CGKD swivel head according to data sheet 17042 13 Connection flange, cylinder "MF3" (installation at the head side) 14 M10 thread for attachment device 3 x R900003438, RING BOLT DIN580-M10-C15E (included in scope of delivery) 15 Space required to remove the connector |
|---|---|

Mounting screws (separate order)

Version	Clamping length	Quantity	Hexagon socket head cap screws (screw length for minimum screw-in depth 1.2 x d)		Torque +/- 5% 1)	Material number for mounting kit
040/028	25	6	HEXAGON SOCKET HEAD CAP SCREW	ISO4762-M10X40-10.9-&	57.5 Nm	R901564086
	105	2	HEXAGON SOCKET HEAD CAP SCREW	ISO4762-M10X120-10.9&		
050/036	25	6	HEXAGON SOCKET HEAD CAP SCREW	ISO4762-M12X40-10.9-&	100 Nm	R901564085
	105	2	HEXAGON SOCKET HEAD CAP SCREW	ISO4762-M12X120-10.9&		
063/045	28	6	HEXAGON SOCKET HEAD CAP SCREW	ISO4762-M12X45-10.9-&	100 Nm	R901564084
	108	2	HEXAGON SOCKET HEAD CAP SCREW	ISO4762-M12X125-10.9&		
080/056	32	6	HEXAGON SOCKET HEAD CAP SCREW	ISO4762-M16X55-10.9-&	245 Nm	R901564083
	112	2	HEXAGON SOCKET HEAD CAP SCREW	ISO4762-M16X135-10.9&		

1) Maximum admissible torque of the specified hexagon socket head cap screws

Electrical connections, assignment – individual connection

Device connector for motor, motor temperature and resolver

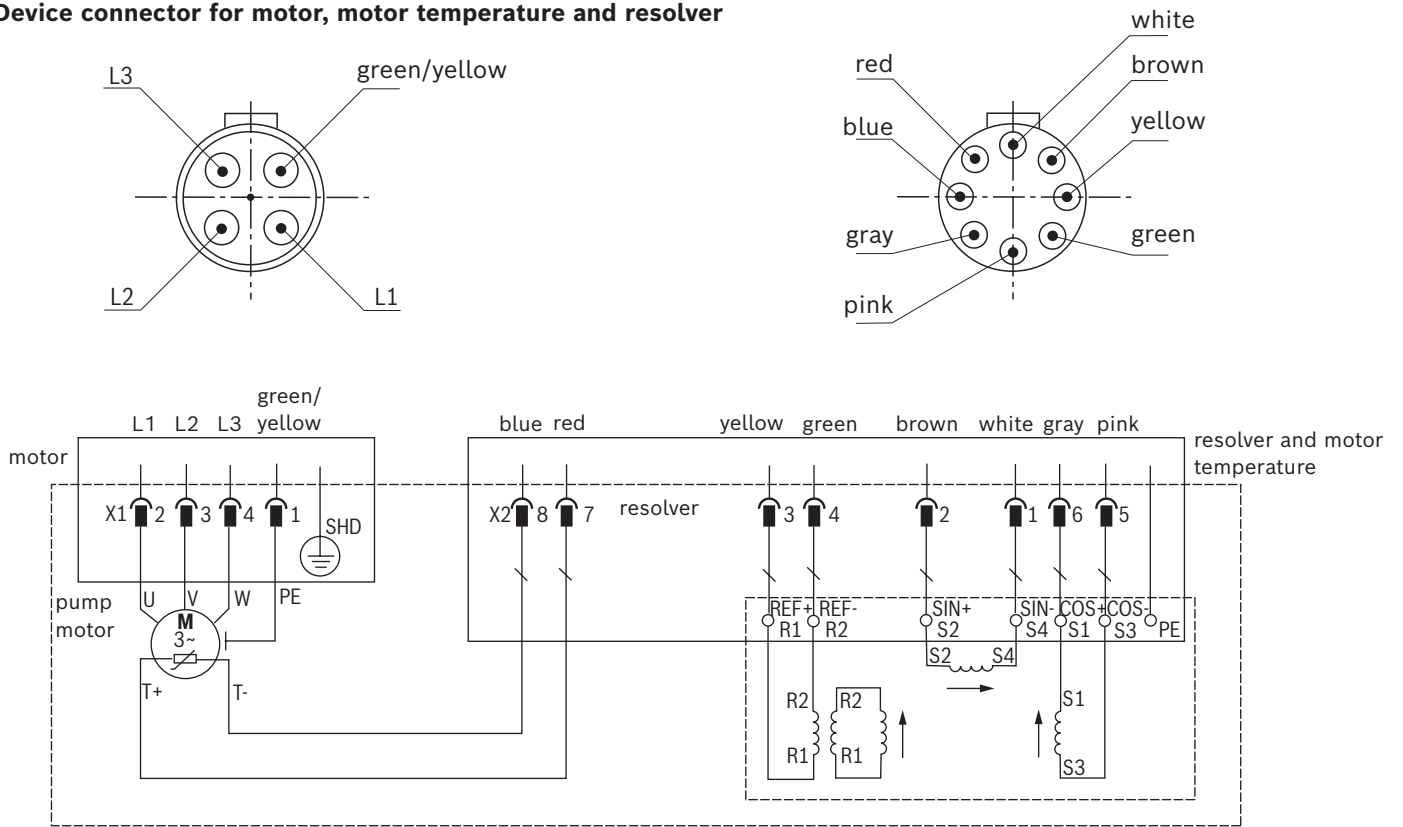

Device connector for 2/2 directional seat valves

Ordering code for connector	Top view	Circuit diagram	Pin	Connections, assignment
Connector 3-pole (2 + PE) according to DIN EN 175301-803			1	Solenoid coil, polarity-independent
			2	Grounding

Device connector for pressure transducer, 4-pole, M12 x 1

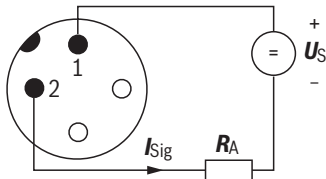

Device connector for position measurement system

(View to pin side)

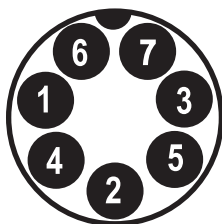

Pin	Cable	Function
1	Gray	Data (-)
2	Pink	Data (+)
3	Yellow	Clock (+)
4	Green	Clock (-)
5	Brown	+12 ... 30 VDC ±20% (9.6 ... 36 VDC)
6	White	DC ground (0 V)
7	-	Not used

Accessories (separate order)

Designation		Version	Material number	Data sheet/standard
Cable set, motor				
ASSEMBLY	CBL-1X/MOT-10W4X02.5	4-pole, angled, 10 m	R901559242	See dimensions on page 9
Resolver cable set and motor temperature				
ASSEMBLY	CBL-1X/CRT-10W8XSPEZ	8-pole, angled, 10 m	R901559243	See dimensions on page 9
Mating connectors for on/off valves				
Mating connector; for valves with device connectors, 2-pole + PE, design A		Without circuitry, M16 x 1.5, 12 ... 240 V, "b"	R901017011	08006
		With indicator light, M16 x 1.5, 12 ... 240 V	R901017022	
Mating connectors and cable sets for pressure transducers				
Cable sets	M12 x 1, 4-pole, straight, 2.0 m		R900773031	08006
	M12 x 1, 4-pole, straight, 5.0 m		R900779498	
Mating connectors	M12 x 1, 4-pole, straight, PG 7		R900773042	
Mating connector for position measurement system				
MATING CONNECTOR	7P STC09131D07	M16, 7-pole, straight	R900079551	See dimensions on page 9
Mounting kit (screw lengths for minimum screw-in depth 1.2 x d)				
ASSEMBLY	MKT-1X/040M10/10.9ZN	Version "040/028" 6x HEXAGON SOCKET HEAD CAP SCREW ISO4762-M10X40-10.9& 2x HEXAGON SOCKET HEAD CAP SCREW ISO4762-M10X120-10.9&	R901564086	ISO 4762
ASSEMBLY	MKT-1X/050M12/10.9ZN	Version "050/036" 6x HEXAGON SOCKET HEAD CAP SCREW ISO4762-M12X40-10.9-& 2x HEXAGON SOCKET HEAD CAP SCREW ISO4762-M12X120-10.9&	R901564085	ISO 4762
ASSEMBLY	MKT-1X/063M12/10.9ZN	Version "063/045" 6x HEXAGON SOCKET HEAD CAP SCREW ISO4762-M12X45-10.9-& 2x HEXAGON SOCKET HEAD CAP SCREW ISO4762-M12X125-10.9&	R901564084	ISO 4762
ASSEMBLY	MKT-1X/080M16/10.9ZN	Version "080/056" 6x HEXAGON SOCKET HEAD CAP SCREW ISO4762-M16X55-10.9-& 2x HEXAGON SOCKET HEAD CAP SCREW SO4762-M16X135-10.9&	R901564083	ISO 4762

Further information**CytroMotion**

- ▶ Operating instructions

Instructions 62290-B

Electrics

- ▶ Pressure transducer for hydraulic applications
- ▶ Cable sets and valve plugs

Data sheet 30272

Data sheet 08006

Cylinder

- ▶ Mounting elements for hydraulic cylinders

Data sheet 17042

Bosch Rexroth AG
Industrial Hydraulics
Zum Eisengießer 1
97816 Lohr am Main, Germany
Phone +49 (0) 93 52/40 30 20
my.support@boschrexroth.de
www.boschrexroth.de

© All rights reserved to Bosch Rexroth AG, also regarding any disposal, exploitation, reproduction, editing, distribution, as well as in the event of applications for industrial property rights.
The data specified above only serve to describe the product.
No statements concerning a certain condition or suitability for a certain application can be derived from our information. The information given does not release the user from the obligation of own judgment and verification. It must be remembered that our products are subject to a natural process of wear and aging.