



Accumulator Charging Valve

For mounting on hydraulic pumps and motors
Series AGSF



- Soft switching
- Cartridge is thick-film passivated, Cr(VI)-free
- High levels of functionality and stability

PO Box 38
Strathfieldsaye, VIC, 3551
1800 OIL SOL
1800 645 765

sales@oilsolutions.com.au

www.oilsolutions.com.au

"For All Your Hydraulic Needs"

1 Product description

1.1 General

The series AGSF accumulator charging valve is a two-stage, high-performance flange-mounting valve with an interface to SAE J518 code 61 and ISO 6162-1. The main components of the valve are a body and a mechanically self-operated two-stage pressure-unloading cartridge. The accumulator charging valve is a cartridge unit with a seated pilot stage and a spool-type main stage and leak-free ball-type pilot stage.

The changeover to unloaded bypass is a soft-switching one, with damped switching characteristics.

Accumulator charging valves are used wherever a pump has to be disconnected from and re-connected to a pres-

sure circuit. For this purpose, either the 'Off' pressure or the 'On' pressure of the cartridge can be set. When the 'Off' pressure is set, the 'On' point will depend on the selected percentage on-off pressure differential, or the other way round. To disconnect the pump, the cartridge responds to increasing pressures at ports A and X by opening the connection from A → B. This connection is then kept open until the selected percentage on-off pressure differential is reached (falling pressure at port X) and the connection A → B closes again (the 'On' point).

The valve is mounted directly on the pump's flange interface.

1.2 Other applicable documentation

Description	Fitted in nominal sizes	Data sheet
Cartridge valve DWPBU....	SAE 1/2", SAE 3/4" and SAE 1"	400-P-380101

2 Technical data

General characteristics	Description, value, unit
Design	flange-mounting, combined ball-seat/spool type design
Type of operation	Mechanically self-operated
Mounting method (standard)	Interface to SAE J518 code 61 and ISO 6162-1 (mounting bolts are not included in the delivery)
Installation attitude	unrestricted
Flow rate Q_{max}	60 l/min
Operating pressure	SAE 1/2", SAE 3/4" and SAE 1" = maximum 315 bar
Opening pressure for the check valve (type "R" only)	0.3 bar
On-off pressure-differential ranges ¹⁾ (on-off differential from 'Off' (unload) pressure)	27 ... 33% --> other on-off pressure diff. ranges by consultation
Adjustment range	40 ... 315 bar in three pressure ranges

General characteristics	Description, value, unit
Maximum permissible pressure at port T	20 bar (the pressure at port T is additive to the setting at the pressure-relief adjustment)
Min. fluid cleanliness level	NAS 1638, class 9 or ISO 4406, code 20/18/15
Hydraulic fluid	Mineral oil to DIN 51524 and 51525 (other fluids by consultation)
Viscosity range	10 to 500 mm ² /s. Recommended: 15 to 250 mm ² /s
Fluid temperature (Observe viscosity limits for respective fluids)	min. -25°C, max. +80°C (HFA to +50°C max.) Optimum range: +30°C ... +60°C
Body material	GGG40



ATTENTION!

- 1) Any back-pressure in port B (tank) directly reduces the on-off pressure differential.
Recommended back-pressure ≤ 1 bar.

3 Symbol

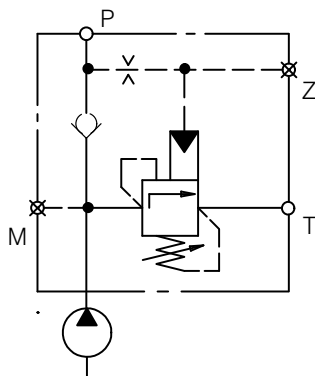

4 Application example

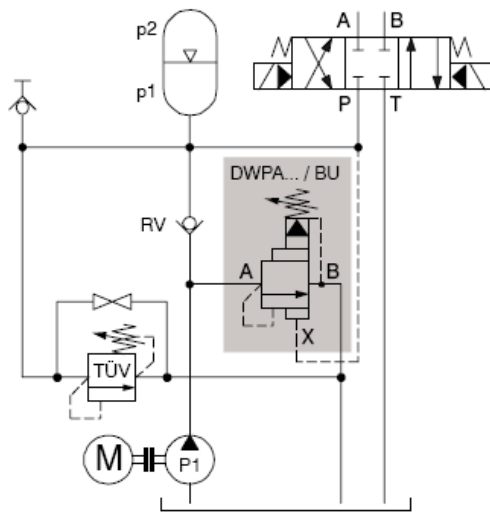

p1 = 'On' pressure
p2 = 'Off' pressure

Accumulator charging circuit

In this application, the DWPBU-2... unloading cartridge performs an automatic accumulator-charging function in response to the pressures at ports A and X.

Here, the normal procedure is to use the adjusting screw to set the upper, 'Off' pressure p2, and when this pressure is reached the pump will therefore be switched over to unloaded bypass (connection A → B open). The selected on-off pressure differential determines the lower, 'On' pressure, p1. When demand causes the pressure in the accumulator circuit to fall to p1, the unloading cartridge closes the connection A → B and the pump supplies oil to the accumulator circuit until the 'Off' pressure p2 is reached and another 'unload' occurs.

5 Performance graphs (measured at 33 mm²/s [cSt])

5.1 Size 1/2", 3/4" and 1"

5.1.1 Pressure drop v. flow rate characteristic (pressure-relief function)

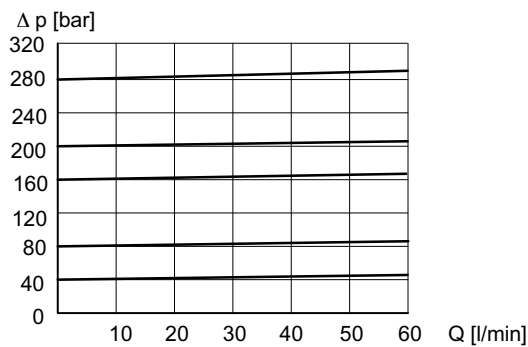

5.1.2 Minimum off-load pressure (no flow)

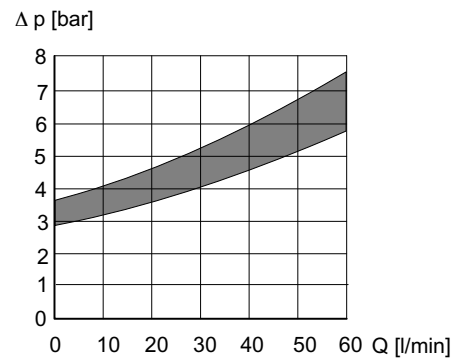

5.1.3 Leakage from A to B

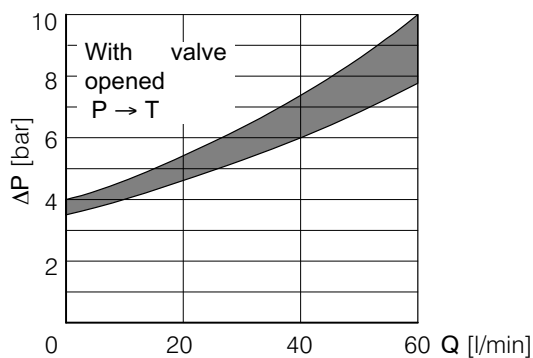

6 Dimensions

6.1 With threaded ports (series AGSF)

6.1.1 Size 1/2"

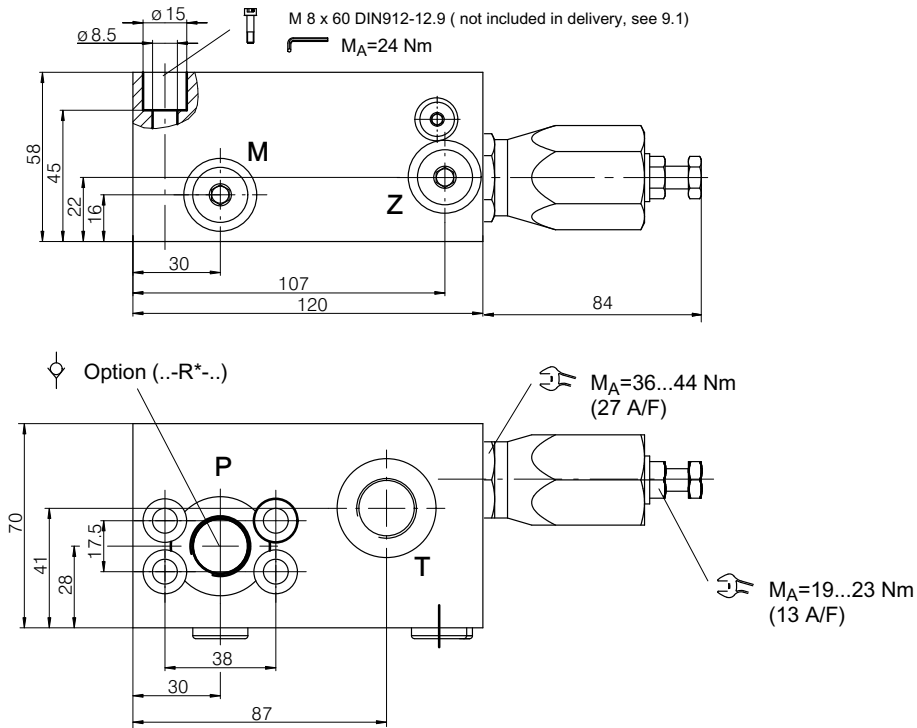

6.1.2 Size 3/4" and 1"

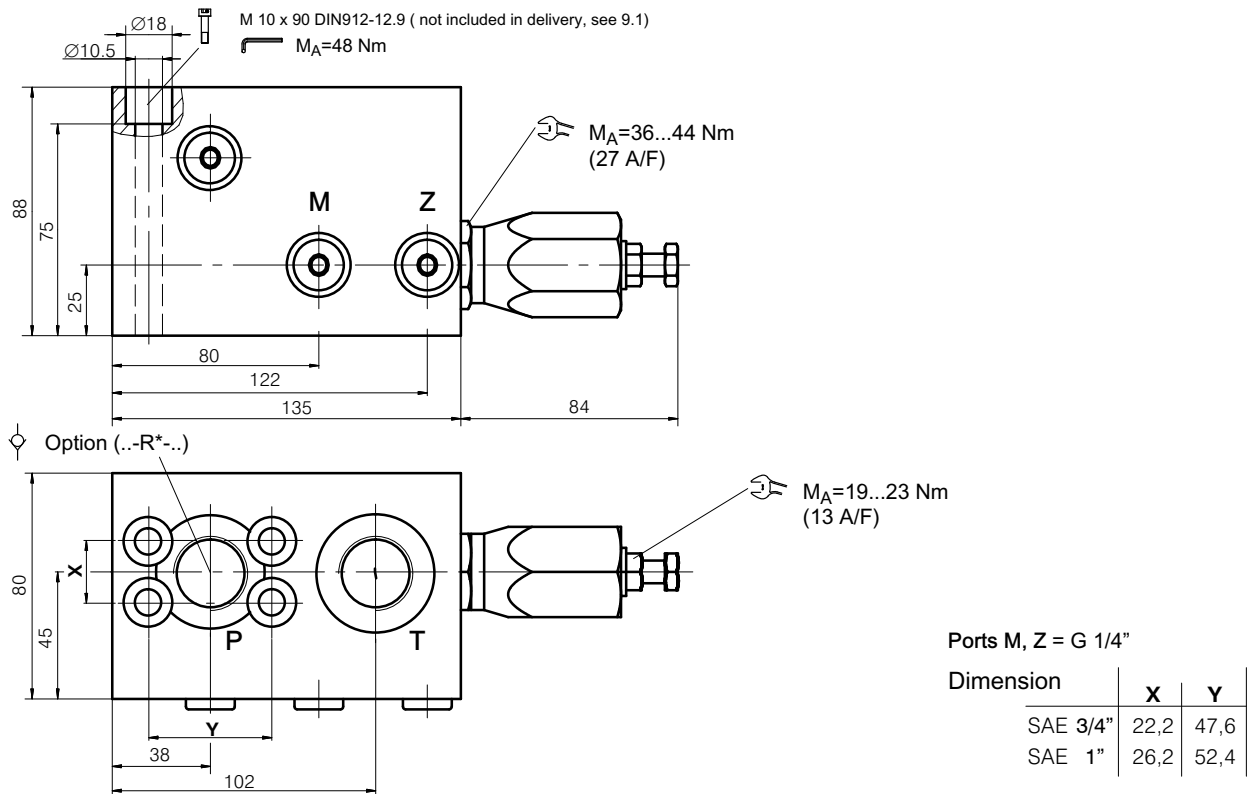

7 Installation information

- Mounting bolts for fitting the valve are not included in the delivery
- Sealing ring for the flange side (pump) is included in the delivery
- Required surface finish of flange pad for mounting the valve

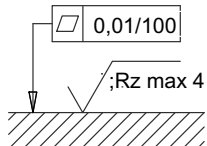

IMPORTANT!

When fitting the valves, use the specified tightening torque for the mounting bolts. The pressure-relief function is factory-set. The setting must be checked.



ATTENTION!

Only qualified personnel with mechanical skills may carry out any maintenance work. Generally, the only work that should ever be undertaken is to check, and possibly replace, the seals. When changing seals, oil or grease the new seals thoroughly before fitting them.

8 Ordering code

	A	G	S, F	2	-	1, /, 2	-	R, *	-	0	P= 1)
SAE bolt-on valve											
With threaded ports		= G									
Accumulator charging valve			= SF								
Adjustment range											
Nominal size											
threaded ports in P and T											
Check valve integrated in threaded-port P											
Without check valve											
Remote-control port Z											
Without port Z											
Design stage (to be inserted by the factory)											

1) Specify the required pressure setting (P max) in plain text.

2) The standard on-off pressure differential is 30% (others by consultation)



IMPORTANT!

- Mounting bolts for fitting the valve are not included in the delivery and must be ordered separately (see Section 9.1).
- Sealing ring for the flange side (pump) is included in the delivery
- There must not be any pressure peaks at the tank port → the cartridge seat could be damaged!

9 Accessories

9.1 Cap screws

Description	Ordering code	Data sheet
Cap screws M8 x 60 - DIN 912-12.9	100234776	100-D-404947
Cap screws M10 x 90 - DIN 912-12.9	100240420	100-D-404947

10 Selection table

10.1 Possible ordering variants

Connection type	Pump	Bolt-on valve	Functions			
			With integral check valve	Without check valve	With remote-control port	Without remote-control port
Thread	QX2./117	AGSF_-1/2-	x	x	x	x
	QX3./117	AGSF_-3/4-	x	x	x	x
	QX4.	AGSF_-1/1-	x	x	x	x

11 Installation example

11.1 AGSF bolt-on assembly on series QX42 internal gear pump

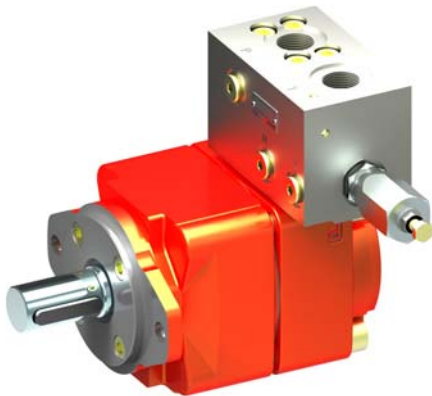

info.kl@bucherhydraulics.com

www.bucherhydraulics.com

© 2015 by Bucher Hydraulics GmbH, D-79771 Klettgau

All rights reserved.

Data is provided for the purpose of product description only, and must not be construed as warranted characteristics in the legal sense. The information does not relieve users from the duty of conducting their own evaluations and tests. Because the products are subject to continual improvement, we reserve the right to amend the product specifications contained in this catalogue.

Classification: 430.310.