

3.6 Model M-3311 (Formerly M-311)

Description

- Pump / Motor / Reservoir / Valve
- Manually Operated 2-Way/2-Position Normally Closed Valve With Motor Start Switch
- Metered Spool for Fine Control of Lowering Speed
- Check Valve
- Externally Adjustable Relief Valve
- #4 SAE Outlet
- Horizontal Mounting Standard

Schematic

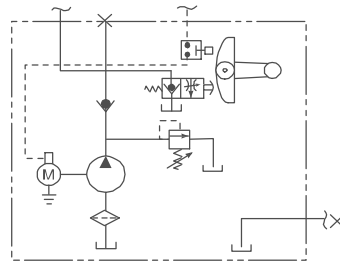

Popular Options

- Non-Metered Lowering Spool
- Vertical Mounting / Motor Up

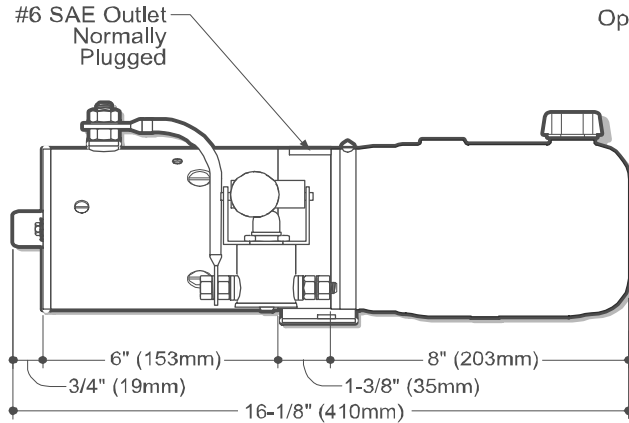

SIDE VIEW

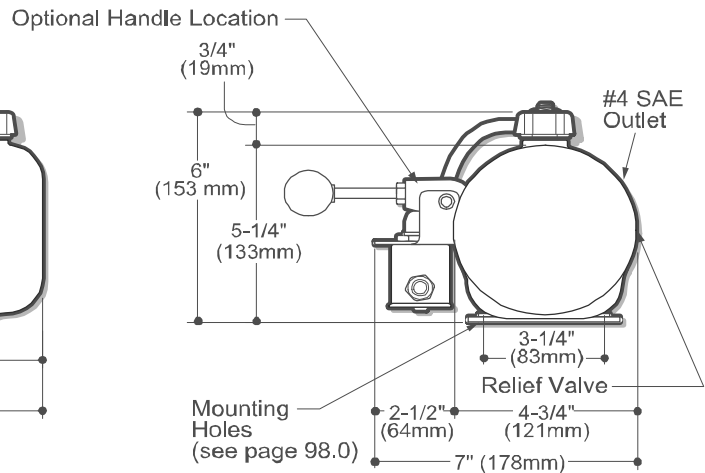

END VIEW

Optional Eye-Bolt



How to Order Your M-3311

Comprehensive information may be found on the page referenced below each selection category.

Shown as standard with:

Pump	Motor	Voltage	Reservoir (Length)	Mounting Bracket	Accessories
	08111	12	06102	04560	
Ref. Page	Ref. Page 52		Ref. Page 76-86	Ref. Page 91	Ref. Page 92



1800-OILSOL
1800-645765

<https://oilsolutions.com.au/>

sales@oilsolutions.com.au