

3.16 Model M-3314 (Formerly M-314)

Description

- Pump / Motor / Reservoir / Valve
- Check Valve
- 2-Way/2-Position Normally Closed Solenoid Operated Lowering Valve and Return Filter Installed in Reservoir
- Manual Override for Emergency Lowering During Power Loss
- Externally Adjustable Relief Valve
- #6 SAE Outlet
- Horizontal Mounting Standard

Popular Options

- Control Box and Cord
- Vertical Mounting / Motor Up

Schematic

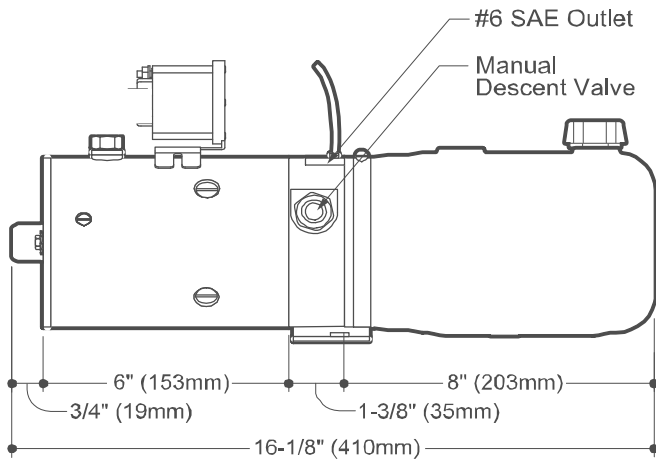
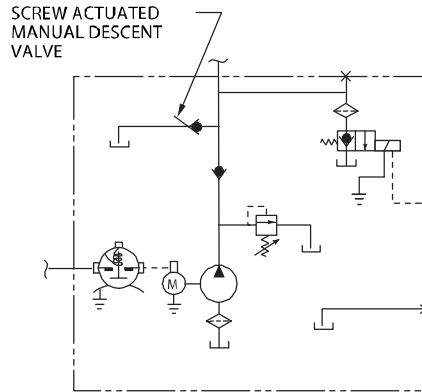

SIDE VIEW

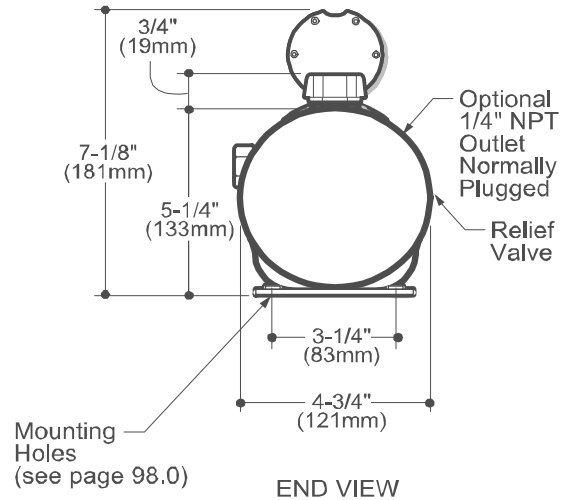

END VIEW

How to Order Your M-3314

Comprehensive information may be found on the page referenced below each selection category.

Shown as standard with:

Pump	Motor	Voltage	Reservoir (Length)	Cartridge Valve	Motor Start Switch	Mounting Bracket	Mounting Position	Accessories	Control Boxes
	08111	12	06102		17757	04560	Horizontal		
Ref. Page	Ref. Page 52		Ref. Page 76-86	Ref. Page 87	Ref. Page 89	Ref. Page 91		Ref. Page 92	Ref. Page 90



1800-OILSOL
1800-645765

<https://oilsolutions.com.au/>

sales@oilsolutions.com.au