

3.13 Model M-3519-HF

Description

- Pump/Motor/Reservoir/High Flow Lowering Valve
- Pressure Drop Thru Base <100 PSI (6.9 Bar) at 8 GPM (30 LPM) With Needle Valve Completely Open for Fast Lowering Speed
- Check Valve
- Externally Adjustable Relief Valve
- 2 Way/2 Position Normally Closed Solenoid Cartridge Valve
- Horizontal Mounting Standard
- Manual Needle Valve for Adjusting Lowering Speed With Tamper Resistant Locking Cap
- #8 SAE Outlet

Schematic

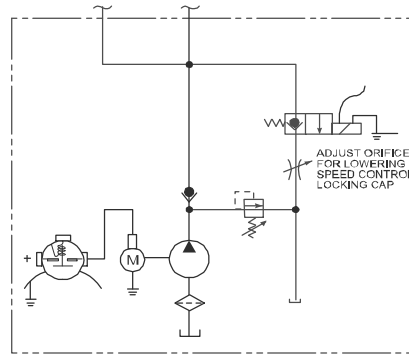

Popular Options

- Control Box and Cord
- Vertical Mounting / Motor Up

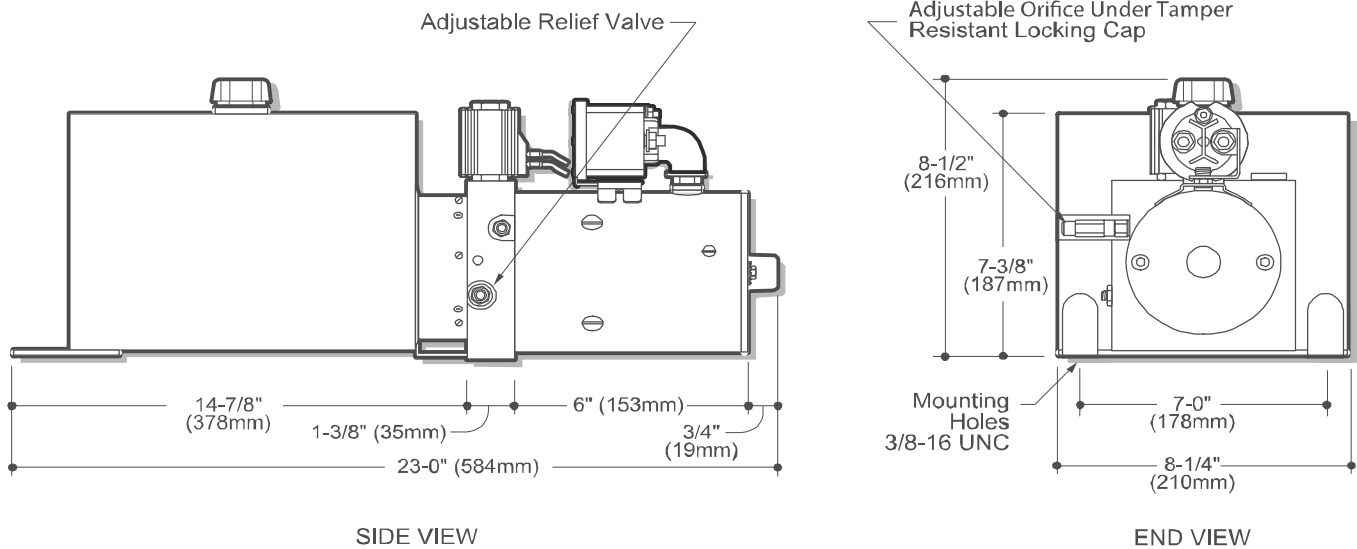

How to Order Your M-3519-HF

Comprehensive information may be found on the page referenced below each selection category.

Shown as standard with:

Pump	Motor	Voltage	Reservoir (Length)	Motor Start Switch	Mounting Position	Accessories	Control Boxes
	08111	12	06328	17757	Horizontal		
Ref. Page	Ref. Page 52		Ref. Page 76-86	Ref. Page 89		Ref. Page 92	Ref. Page 90



1800-OILSOL
1800-645765

<https://oilsolutions.com.au/>

sales@oilsolutions.com.au