

3.27 Model M-3552

Description

- Pump / Motor / Reservoir / Valve
- Check Valve
- Externally Adjustable Relief Valve
- 1 x 4-Way/2-Position Solenoid Cartridge Valve and 1 x 2-Way/2-Position Solenoid Cartridge Valve Located Externally. Manifolded Directly To Unit
- C1 Port Positively Checked
- Externally Adjustable Relief Valve in C2 Port
- #6 SAE Outlet
- Horizontal Mounting Standard

Popular Options

- Pressure Compensated (Cartridge Style) Flow Control In C1 Port
- Control Box and Cord
- Vertical Mounting / Motor Up

Schematic

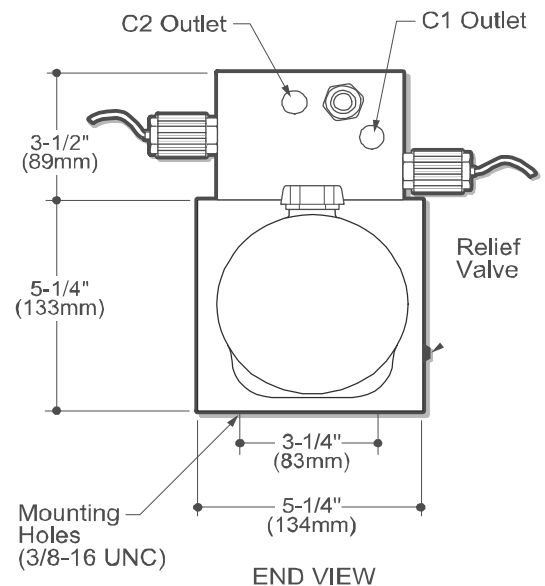
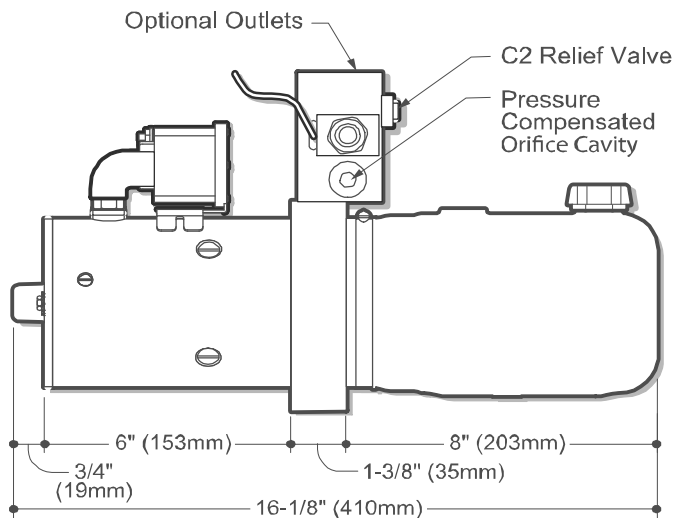
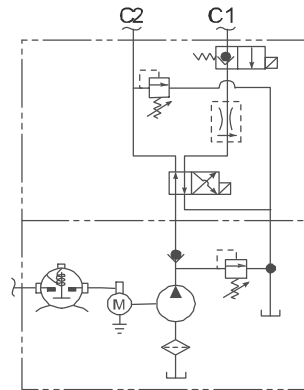

How to Order Your M-3552

Comprehensive information may be found on the page referenced below each selection category.

Shown as standard with:

Pump	Motor	Voltage	Reservoir (Length)	Motor Start Switch	Mounting Position	Accessories	Control Boxes
	08111	12	06102	17757	Horizontal		
Ref. Page	Ref. Page 52		Ref. Page 76-86	Ref. Page 89		Ref. Page 92	Ref. Page 90



1800-OILSOL
1800-645765

<https://oilsolutions.com.au/>

sales@oilsolutions.com.au