

3 Monarch A.C. Hydraulic Power Systems

3.1 Model M-4226 Mini System (Formerly M-455)

Description

- Pump Motor Unit
- Check Valve
- Externally Adjustable Relief Valve
- .375 Inch NPT Suction
- 7/16-20 SAE Outlet Port

Schematic

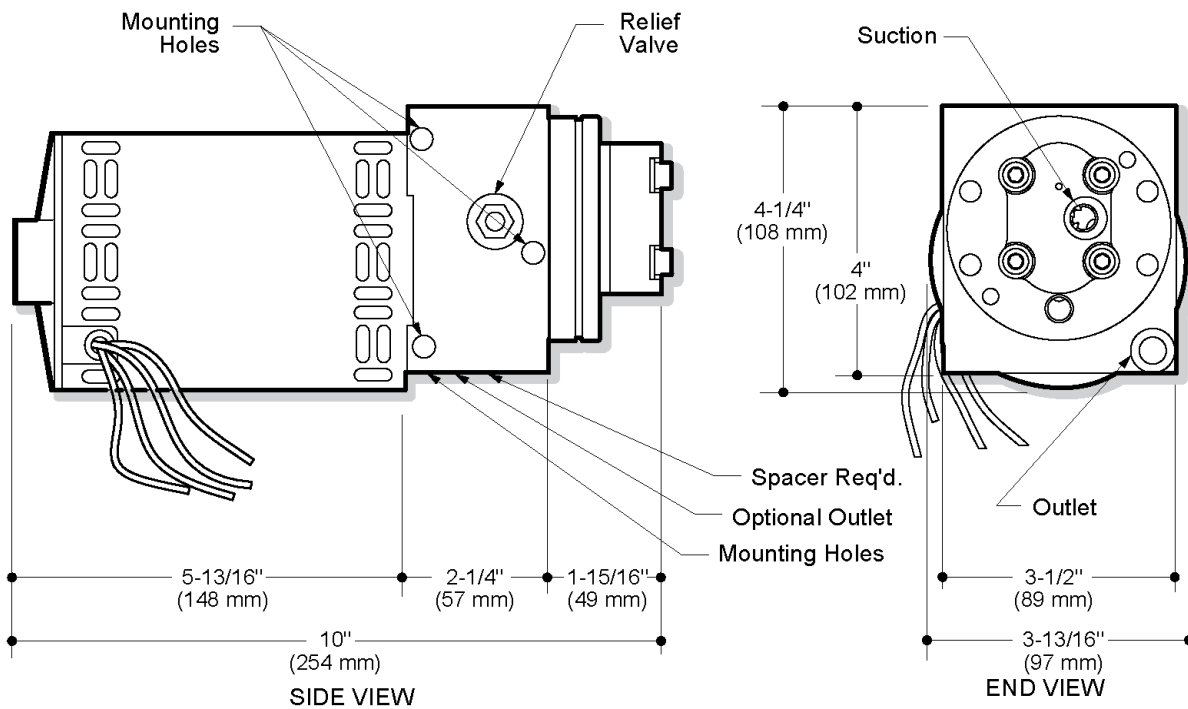
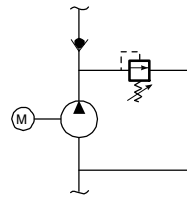

How to Order Your M-4226 Mini System

Comprehensive information may be found on the page referenced below each selection category.

Pump	Motor	Voltage	Mounting Position	Accessories
Ref. Page 9	Ref. Page 10	Ref. Page 10		Ref. Page 20



1800-OILSOL
1800-645765

<https://oilsolutions.com.au/>

sales@oilsolutions.com.au