

3.12 Model M-4319 (Formerly M-419)

Description

- Pump/Motor/Reservoir/Valve Unit
- Solenoid Operated 2-Way/2-Position Normally Closed Valve
- Externally Adjustable Relief Valve
- .375 Inch NPT Outlet
- Horizontal Mounting Standard
- Vertical Mounting (Motor Up) Optional

Schematic

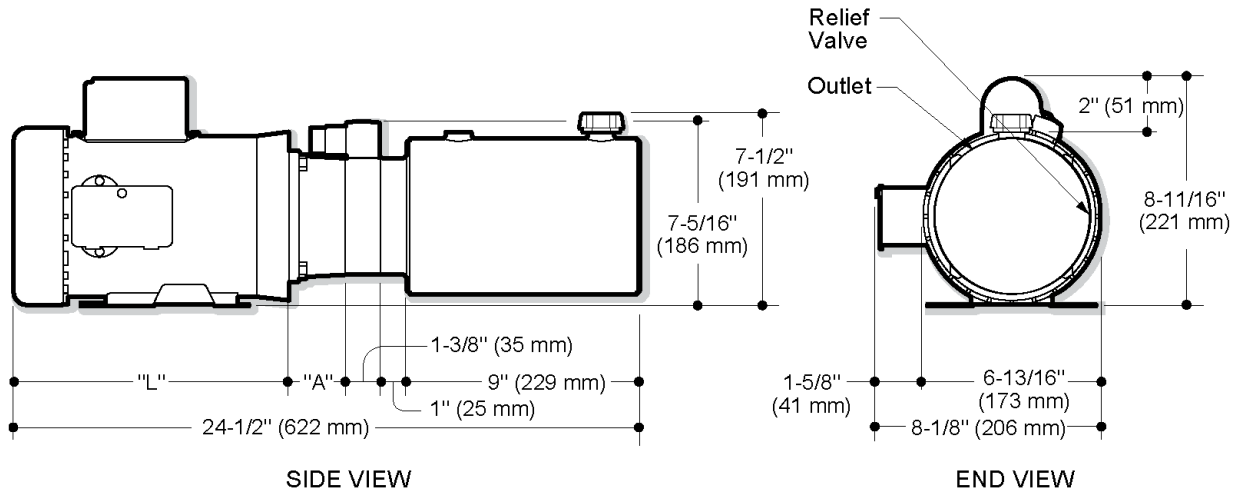
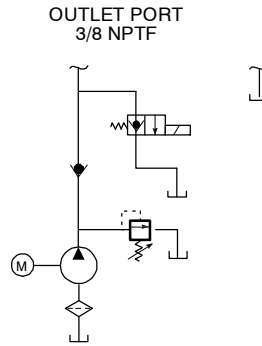

"L" dimension shown for 08751 motor is 10-11/16" (271 mm)
 "A" dimension for standard 01605 adapter is 2-5/32" (55 mm)
 "A" dimension for optional 01615 adapter is 3-11/32" (85 mm)
 Dimensions will vary according to motor output and manufacturer

How to Order Your M-4319 Power System

Comprehensive information may be found on the page referenced below each selection category.

Pump	Motor	Adapter	Reservoir (Length)	Mounting Position	Accessories
Ref. Page 9	Ref. Page 10	Ref. Page 11	Ref. Page 13		Ref. Page 20



1800-OILSOL
1800-645765

<https://oilsolutions.com.au/>

sales@oilsolutions.com.au