

QXT Internal Gear Flow Divider

for up to 4 outlet flows

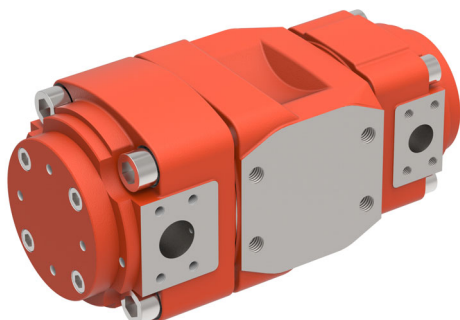

- for up to 4 outlet flows
- extremely high division accuracy
- exceptionally quiet operation thanks to negligible pressure pulsations
- long service life with low maintenance
- high efficiency, since operating principle ensures there are no throttling losses
- wide range of outlet flows are available
- suitable for special fluids such as HFC, environmentally friendly and low viscosity fluids

1 General

1.1 Product description

Series QXT flow dividers are internal gear units that can divide a flow into as many as four portions. The division ratios are constant and are unaffected by the loads at the actuators. They can be used, for example, to provide synchronised movement of unequally loaded cylinders. Several hydraulic motors can be driven at the same speed, irrespective of their external loads. Since they operate on the principle of the rotating internal gear set, these flow dividers work without any throttling losses, which is in strong contrast to spool-type flow dividers. The QXT flow divider can also

be used to produce pressure intensification i.e. the outlet pressure from the flow divider is higher than its inlet pressure. This takes place at high efficiency, since the operating principle ensures that the only losses that can possibly occur are proportional to the pressure difference across the unit. The unit is based on the well-known QX internal gear pump, which is distinguished by its very low noise levels and almost imperceptible pressure pulsations. The large number of closely spaced sizes ensures that the right size is always available for every application.

1.2 Application examples

- Air conditioning Systems
- Track laying machinery
- Waste compactors
- Hydraulic presses
- Scissor lifts
- Charge carriers

2 Symbol

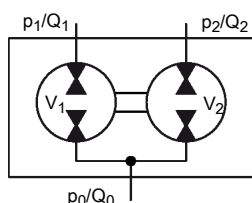

1800-OILSOL
1800-645765

<https://oilsolutions.com.au/>

sales@oilsolutions.com.au

3 Technical data

Characteristics	Unit	Description, Value
Installation attitude		unrestricted
Hydraulic fluid		HLP mineral oils to DIN 51524, Part 2 HFB, HFD and HFC fluids to VDMA 24317
Max admissible level of contamination of the hydraulic fluid		ISO 4406 code 20/18/15
Operating viscosity Starting viscosity	mm ² /s	10 ... 100 * 10 ... 300 * *other values on request
Hydraulic fluid temperature	°C	HLP mineral oil 80°C max., HFB, HFD and HFC 50 °C max.

3.1 Flow dividers with outlet flows of equal sizes

These operating data are valid for mineral oils with 42 mm²/s.

Please contact Bucher if you require unequal outlet flows.

Type	Outlet displacement [cm ³ /U] ³⁾	Cont./ Intern. pressure ¹⁾ [bar]	Speed n _{max} / n _{min} [min ⁻¹]	Maximum inlet flow Q _{0 max}		
				2 outlet flows [l/min]	3 outlet flows ²⁾ [l/min]	4 outlet flows ²⁾ [l/min]
QXT22-005/22-005 QXT22-006/22-006 QXT22-008/22-008	5,1 6,3 7,9	250/320	6300/1250	63 80 100	95 120 150	125 160 200
QXT32-012/32-012 QXT32-016/32-016	12,6 15,6	250/320	5000/1000	120 160	180 240	240 320
QXT42-025/42-025 QXT42-032/42-032	25,1 32,3	250/320	4000/800	200 250	300 380	400 500
QXT52-050/52-050 QXT52-063/52-063	50,3 63,4	250/320	3200/630	320 400	480 600	640 800
QXT62-100/62-100 QXT62-125/62-125	100,5 124,2	250/320	2500/500	500 630	750 950	1000 1260
QXT82-200/82-200 QXT82-250/82-250	200,0 247,7	250/320	2000/400	800 1000	1200 1500	1600 2000

1) Intermittent for max. 20 sec/min but not than 10% of the duty cycle

2) for 3 and 4 outlet flow please contact Bucher Hydraulics

3) Due to manufacturing tolerances, there may be slight variations in the displacement.

3.2 Choose the optimal flow divider

These operating data are valid for mineral oils with 42 mm²/s.

For the highest division accuracy as well as the lowest cost, choose the smallest possible flow divider running near its maximum speed. The speed n in rev/min is calculated from:

$$n = \frac{Q_0 \times 10^3}{V_1 + V_2 + V_3 + \dots}$$

where Q_0 = inlet flow rate in l/min and V_1 = outlet displacement in cm³/rev. The minimum permissible inlet flow rate is calculated from:

$$Q_{0 \min} = \frac{n_{\min}}{n_{\max}} \times Q_{0 \max}$$

In the case of the flow dividers with unequal outlet displacements, use the largest displacement for determining n_{\max} , the smallest for n_{\min} . Since rotary flow dividers are also pressure intensifiers, each outlet circuit must be provided with a pressure relief valve. Bucher Hydraulics series VT relief valves mount directly on the flow divider and are therefore particularly suitable (please request the data sheet 100-D-402850).

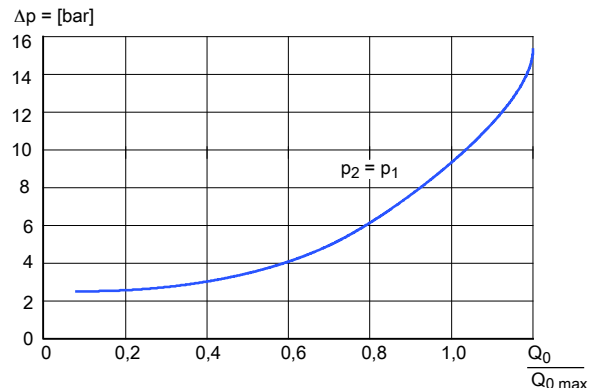

4 Performance curves

These operating data are valid for mineral oils with 42 mm²/s.

Tests carried out on a QXT flow divider, type 32-016/32-016, produced the results shown below. For the same speed, larger flow dividers have a better accuracy while smaller ones display a bigger difference between the two outlet flows. The division accuracy of the outlet flows Q_1 and Q_2 depends mainly on the pressure difference between the two outlet lines and the ratio $Q_0 / Q_{0 \max}$. The pressure drop across the flow divider is dependent on $Q_0 / Q_{0 \max}$. Using the curves, the accuracy of flow division and the pressure drop can be optimised.

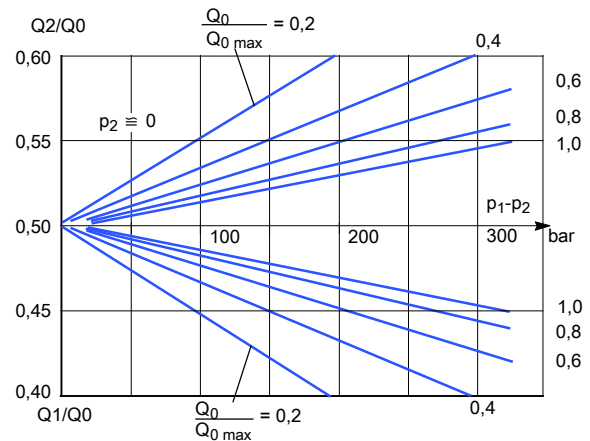

5 Dimensions

5.1 For flow divider with 2 displacements

Frame size	2	3	4	5	6	8
J2	G 1 1/4" thread	G 1 1/2" thread	2" SAE J518 ¹⁾	2" SAE J518 ¹⁾	2" SAE J518 ¹⁾	G 2 1/2" thread
E	G 1/2" thread	G 3/4" thread	1" SAE J518 ¹⁾	1 1/4" SAE J518 ¹⁾	1 1/2" SAE J518 ¹⁾	2" SAE J518 ¹⁾
G	M8x12	M8x12	M10x16	M10x20	M16x28	M20x30
K2	102	129	159,5	190	230,5	282,5
L2	204	258	319	380	461	565
Z	50	60	62,5	78	97,5	125
Q2	67	87	110,5	127	149	178,5
Y	55	60	75	90	112	140
T	85	107	133	177	220	275

1) for SAE J518 code 61 / ISO 6162-1 pipe flange (see section 8.2)

5.2 Frame size 2 - 3

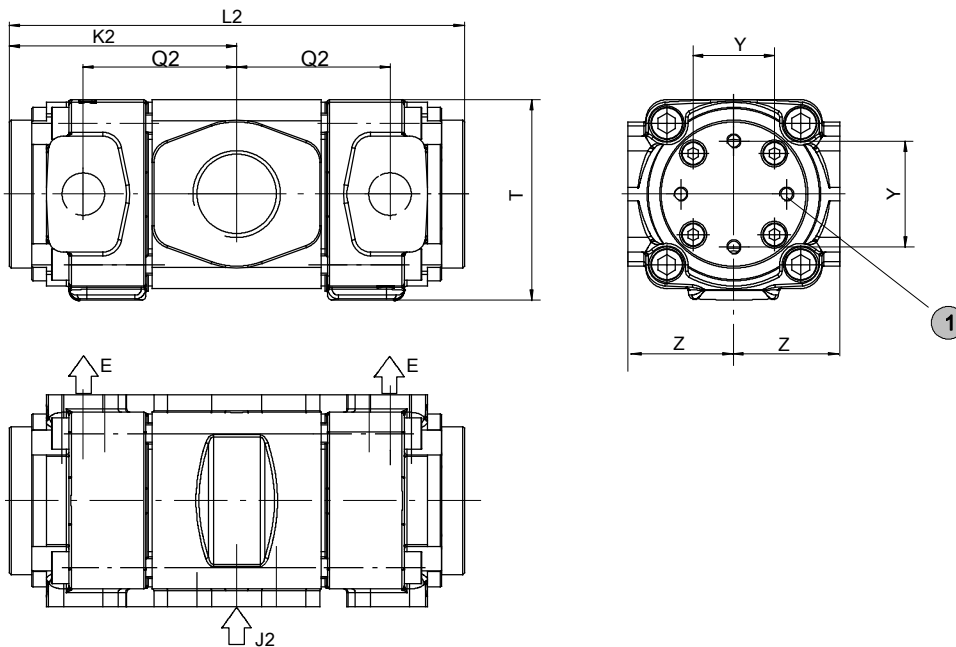

1 Mounting threads
4 x dimensions 'G' - both ends

5.3 Frame size 4 - 6

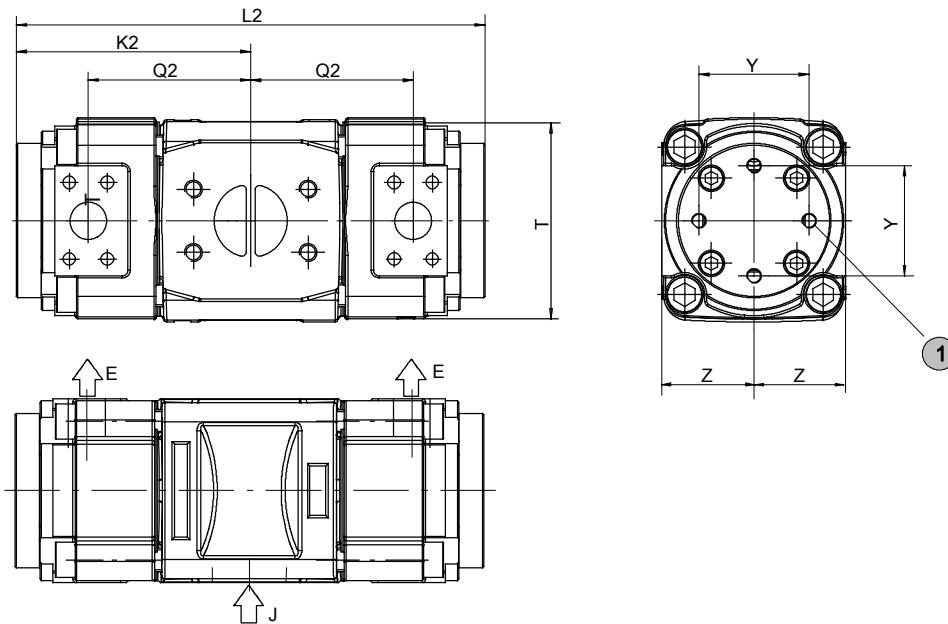

- 1** Mounting threads
4 x dimensions 'G' - both ends

5.4 Frame size 8

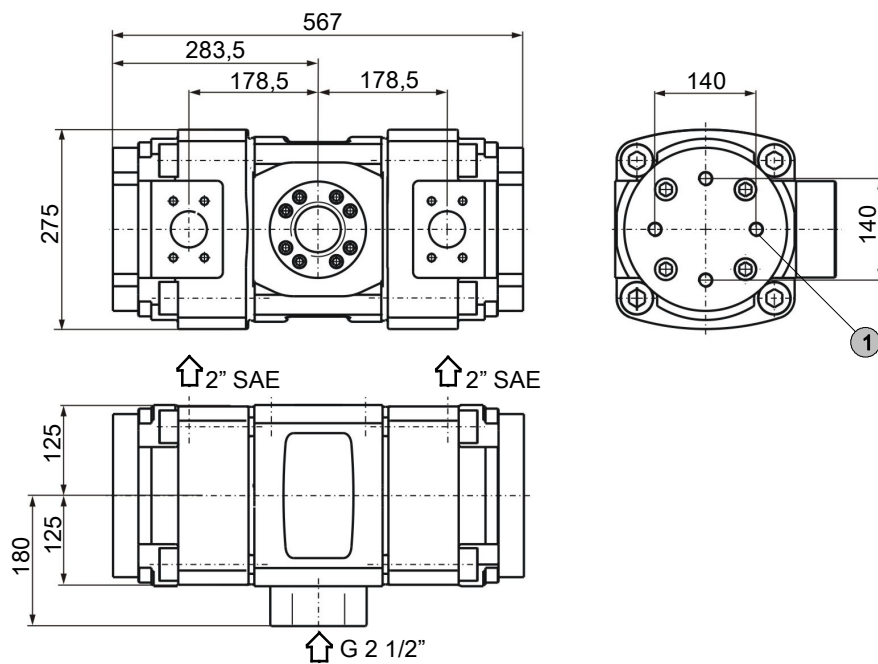

- 1** Mounting threads
4 x dimensions 'G' - both ends

5.5 Flow divider with 3 displacements

(please contact Bucher Hydraulics)

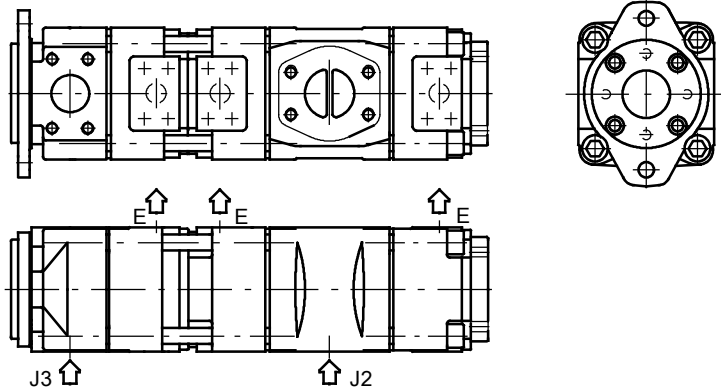

5.6 Flow divider with 4 displacements

(please contact Bucher Hydraulics)

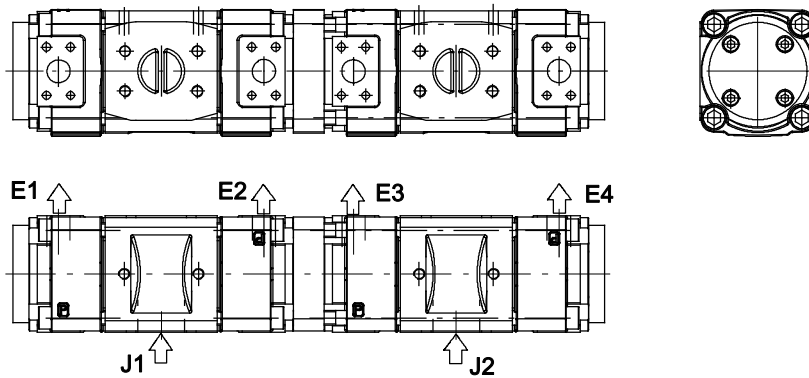

6 Ordering code for 2 displacements

		Q	X	T	3	2	-	0	1	2	/	3	2	-	0	1	2	/	
Series	QXT																		
Frame size	2 / 3 / 4 / 5 / 6 / 8																		
Pressure range 2	2																		
Outlet displacement [cm ³ /U]	005 - 250 (see chapter 3.1)																		
Frame size	2 / 3 / 4 / 5 / 6 / 8																		
Pressure range 2	2																		
Outlet displacement [cm ³ /U]	005 - 250 (see section 3.1)																		
Option	(see section 6.2)																		

6.1 Ordering example

For dividers with 3 outlet flows:
QXT22-005 / 22-005 / 22-005

For dividers with 4 outlet flows:
QXT62-100 / 62-100 / 62-100 / 62-100

Flow divider combinations must contain the same frame sizes, pressure ranges and outlet flows.

If 3, 4 or unequal flows are required, please contact Bucher Hydraulics.

6.2 Option

- O = without priming
- 09 = FPM (Viton) seals and without priming
- 117 = port at outlet (E) in SAE J518 code 61 / ISO 6162I at assembly group 2+3

7 Mounting instructions



Expert and product knowledge is required for the layout of this flow divider. Use exclusively for the intended purpose within the indicated values. The QXT manufacturer must be consulted for use of the appliance outside the specifications. All applications must be verified by sufficient tests to ensure safety in the application. The ultimate responsibility for safety during installation and use resides with the end appliance manufacturer.

CAUTION:

Maintenance work may only be performed by expert personnel with mechanical knowledge.

8 Accessories

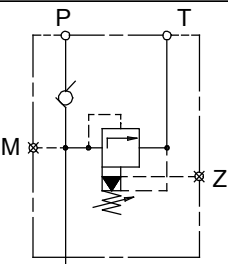
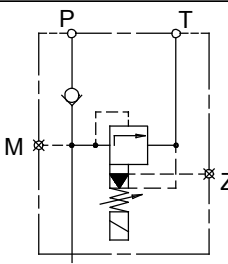
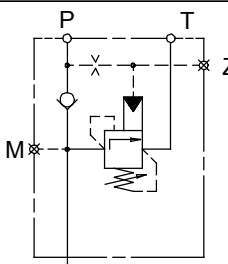
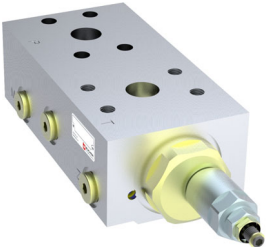
8.1 Bolt-on valves - SAE J518 code 61 / ISO 6162-1 pattern

Pressure relief valve A ^S _G DF	Pressure relief valve solenoid control A ^S _G DA	Accumulator charging valve AGSF
		
		
Technical data sheet 100-P-000123	Technical data sheet 100-P-000119	Technical data sheet 100-P-0000124

8.1.1 Example for Bolt-on valves, mounted on QXT flow divider

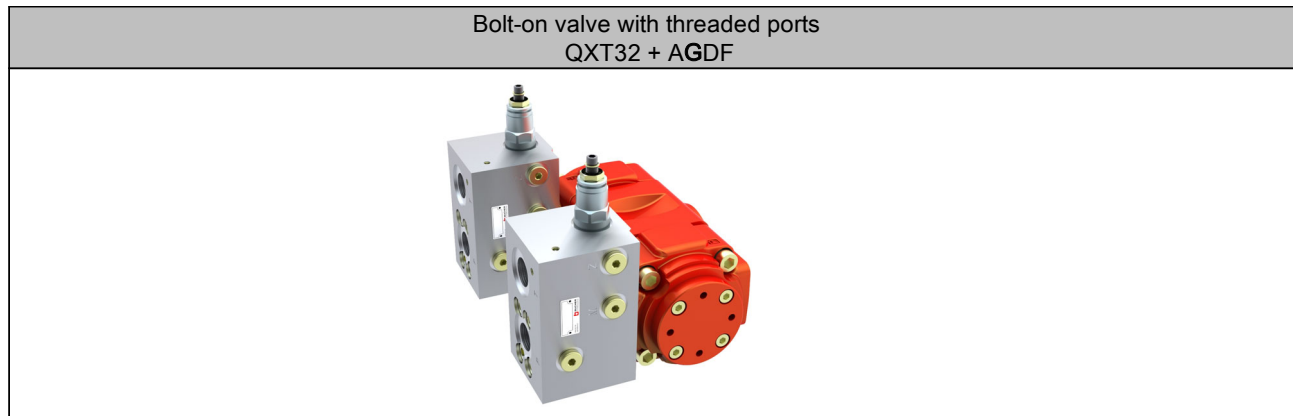

IMPORTANT: For detailed informations on Bolt-on valves see www.bucherhydraulics.com

8.2 Pipe flange - high pressure type

- up to 420 bar
- SAE J518 code 61 / ISO 6162-1 pattern

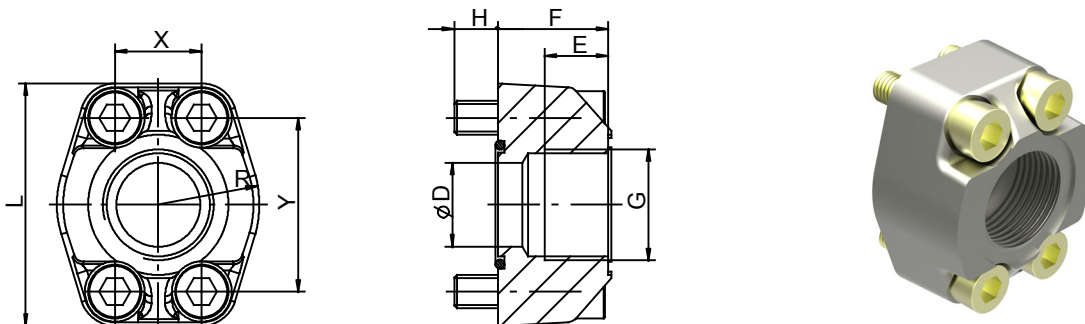

Threaded pipe flanges are spot-faced for pipe fittings.

Material: ST37 / for FPM (Viton) seals contact Bucher Hydraulics.

Order number	Ordering code	Size	D \varnothing	E	F	H	L	R	X	Y	Viton seal 90 Shore 'A'	Retaining screws DIN912-12.9 M [Nm]	
037000	RF 01-R08	G 1/2"	12,5	16	27	13	54	23	17,5	38	20,24x2,62	M8x30	30
037010	RF 02-R10	G 3/4"	20	18	30	12	65	26	22,2	47,6	26,65x2,62	M10x30	60
037020	RF 03-R11	G 1"	25	20	34	13	70	29	26,2	52,4	32,99x2,62	M10x35	60
037030	RF 04-R12	G 1 1/4"	32	22	38	14	80	36	30,2	58,6	40,86x3,53	M10x40	60
037040	RF 05-R13	G 1 1/2"	38	24	41	19	94	41	35,7	70	44,04x3,53	M12x45	120
037050	RF 06-R14	G 2"	50	26	45	20	102	48	42,9	77,8	59,92x3,53	M12x50	120

info.kl@bucherhydraulics.com

www.bucherhydraulics.com

© 2021 by Bucher Hydraulics GmbH, D-79771 Klettgau

All rights reserved.

Data is provided for the purpose of product description only, and must not be construed as warranted characteristics in the legal sense. The information does not relieve users from the duty of conducting their own evaluations and tests. Because the products are subject to continual improvement, we reserve the right to amend the product specifications contained in this catalogue.

Classification: 420.245.370.