

## Safety for Hydraulics

### Proportional valves in sandwich design

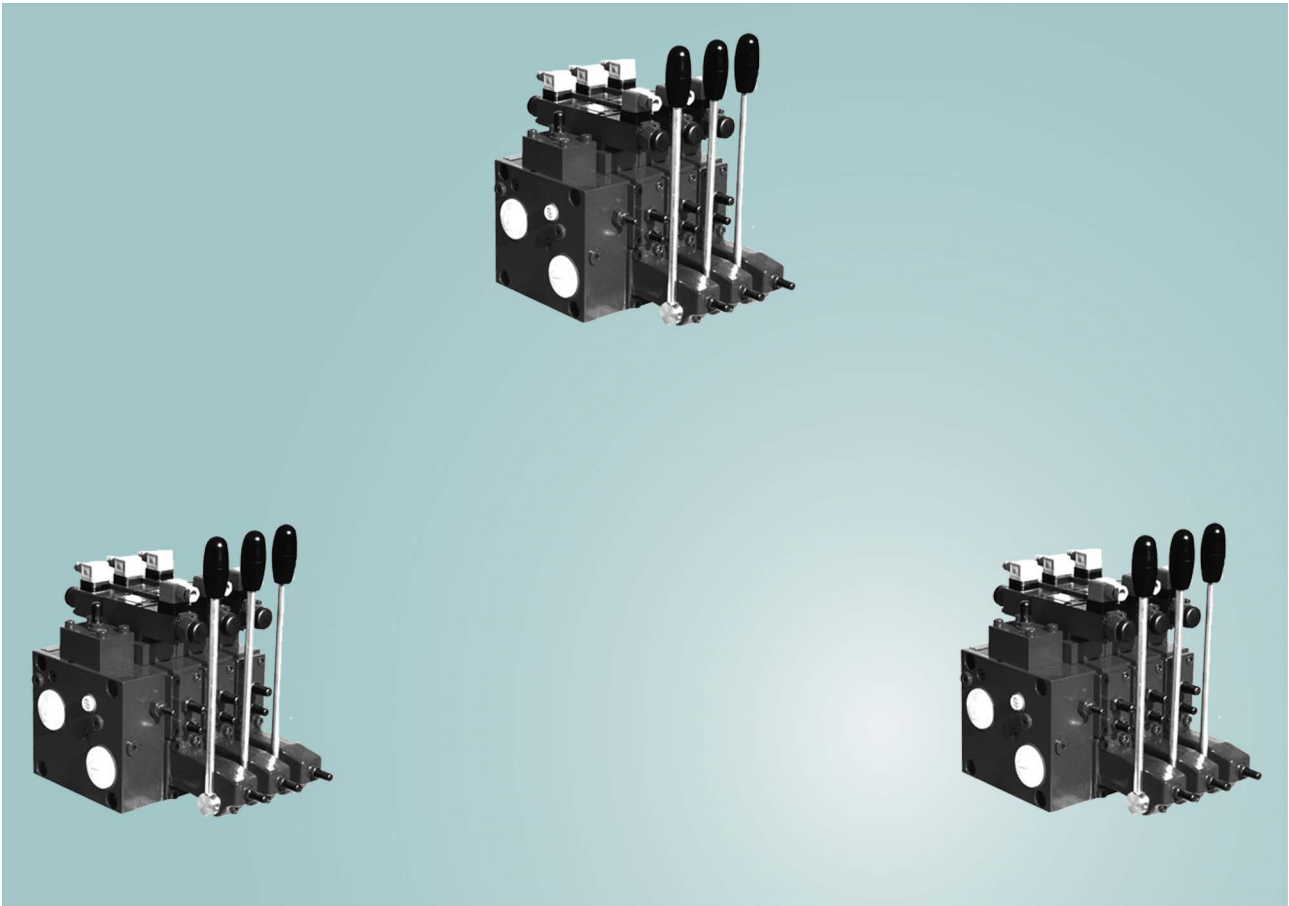

OIL SOLUTIONS

1800-OILSOL  
1800-645765

<https://oilsolutions.com.au/>

[sales@oilsolutions.com.au](mailto:sales@oilsolutions.com.au)

## Contents

## Page

1.	Functional description	3
1.1	Circuits with fixed displacement pump	3
1.2	Circuits with regulable variable displacement pump	4
2.	Description of the valve sections	5
2.1	SU, SO/SF and SL pump connection modules	5
2.2	SY, SZ, SD and SE actuator modules	8
3.	Actuating methods	10
3.1	Manual actuation	10
3.2	Hydraulic actuation	10
3.3	Electrical actuation E1/E2/M2(M1)/M3(M4)	10
3.4	Combined actuation	11
4.	Additional functions	11
4.1	Pressure reduction (control-oil supply)	11
4.2	Actuator flow reduction (AVR)	12
4.3	Adapter plate for combining different nominal sizes of valve	13
4.4	Actuator pressure protection separated on A and B sides	13
5.	Sizes	14
5.1	General	14
5.2	Actuating methods	15
6.	Type codes	17
6.1	Type codes with example for ordering	17
6.2	Position of the hand lever	18
6.3	Spool symbols	19
7.	Dimensions	19
7.1	Pump connection modules	19
7.2	Actuator modules with type of actuation H6	20
7.3	Actuator modules with type of actuation H7	21
7.4	Actuator modules with type of actuation S1, S2, S3, S4	21
7.5	Actuator modules with type of actuation H0	22
7.6	Actuator modules with type of actuation Y0	22
7.7	Actuator modules with type of actuation E1/E2	23
7.8	Actuator modules with type of actuation E7/E8	23
7.9	Actuator modules with type of actuation M2(M1)	24
7.10	Actuator modules with type of actuation M3(M4)	24
7.11	Actuator modules with type of actuation M6(M5) on request only	25
7.12	Actuator modules with type of actuation Y1/Y2	25
7.13	Actuator modules with type of actuation Y7/Y8	26
7.14	Actuator modules with type of actuation B2(B1)	26
7.15	Actuator modules with type of actuation B3(B4)	27
7.16	Actuator modules with type of actuation B6(B5) on request only	27
7.17	Actuator modules with type of actuation K1/K2	28
7.18	Actuator modules with type of actuation K8(K5) on request only	28
7.19	Actuator modules with type of actuation K9(K6)	29
7.20	Actuator modules with type of actuation K0(K7)	29

## 1. Functional description

Bucher's sandwich-type proportional valves control the volumetric flow to the actuator independent of the load, because a 2-way pressure compensator is assigned to each proportional directional control valve in the SZ, SY, SD and SE actuator modules. In addition, the actuator modules comprise primary pressure relief devices that can be adjusted individually for each actuator. The flexible modular system enables the setup to be adapted perfectly to the respective application. The actuating methods available - manual, hydraulic, electrical or any combination

of these - and the various pump connecting modules - with and without pressure compensator or pressure relief valve - open up a wide range of possible applications.

The valve system consists of 2 to 9 individual modules which are held together by tie rods. The entire valve is made up of one pump connecting module (either SU, SL or SO/SF), 1 to 7 SY/SZ actuator modules and one SD/SE actuator module as the end section.

All proportional directional control valves are equipped with an internal load

check-back signaling device for the 2-way pressure compensator that belongs to them. The highest load pressure signal is fed via selector valves to the pump connecting module. At this module, the signal is available either to the SU pressure compensator or for actuating regulable pumps (SO, SL, SF) via port XL. When the proportional directional control valves are in their neutral position, the load on the load signaling channels and pressure compensator spring cavities can be relieved via 2 series-connected nozzles.

### 1.1 Circuits with fixed displacement pump

#### 1.1.1 SU pump connecting module

Preferred application with fixed displacement pump for simultaneous, load-independent actuation of a number of

actuators. The SU pump connecting module takes care of maximum pressure protection for the complete system

and also acts as a recirculation valve to provide as good as pressureless circulation when actuators are not actuated.

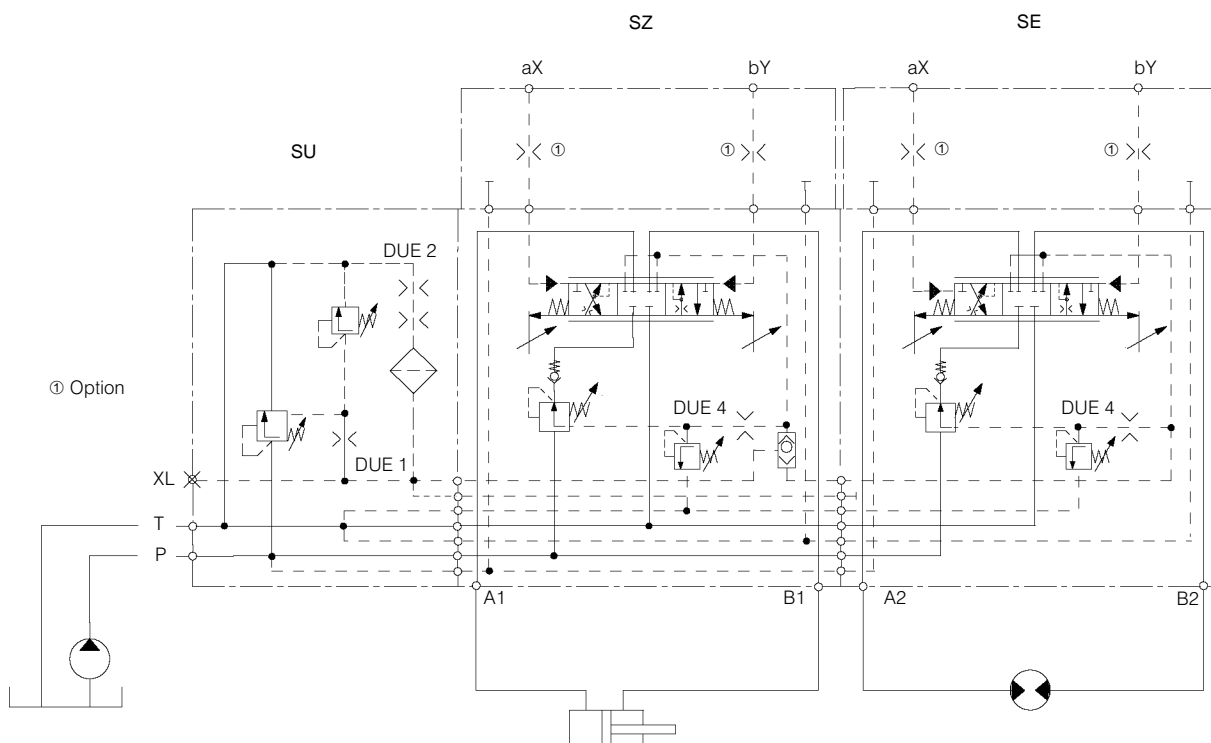

## 1.2 Circuits with regulable variable displacement pump

### 1.2.1 SO/SF pump connecting module

Preferred application with variable displacement pumps for simultaneous, load-independent actuation of a number of actuators. The variable displacement pump can operate pressure-regulated (a) or pressure- and delivery-rate-regulated (load-sensing principle) (b). The load check-back signal is sent to the pump regulator via port XL. Alternatively, the load on the load signaling channel can be relieved in the pump regulator or in the SF pump connecting module.

SO pump connecting module: without relief nozzles  
SF pump connecting module: with relief nozzles

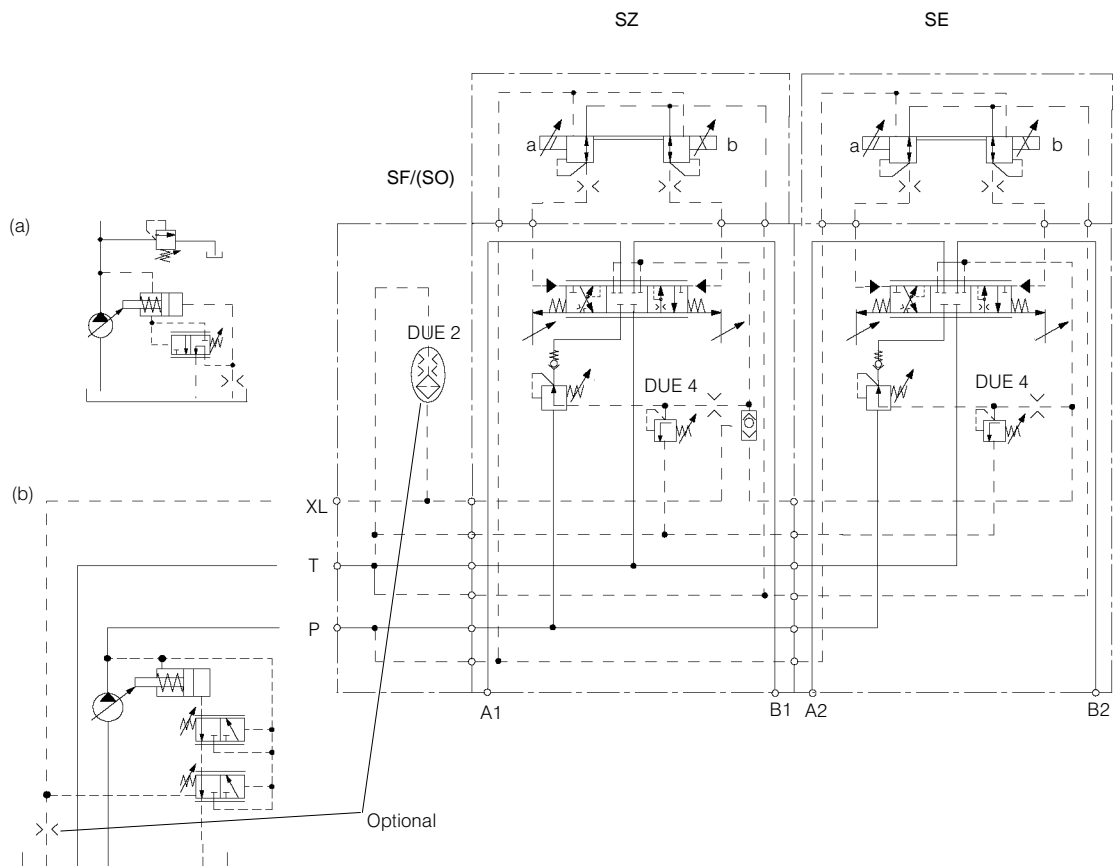

### 1.2.2 SL pump connecting module (pressure relief valve)

If pressure-regulated (a) or pressure- and delivery-rate-regulated (load-sensing principle) (b) variable displa-

cement pumps also have to be protected against pressure peaks, an SL

pump connecting module with primary pressure relief must be fitted.

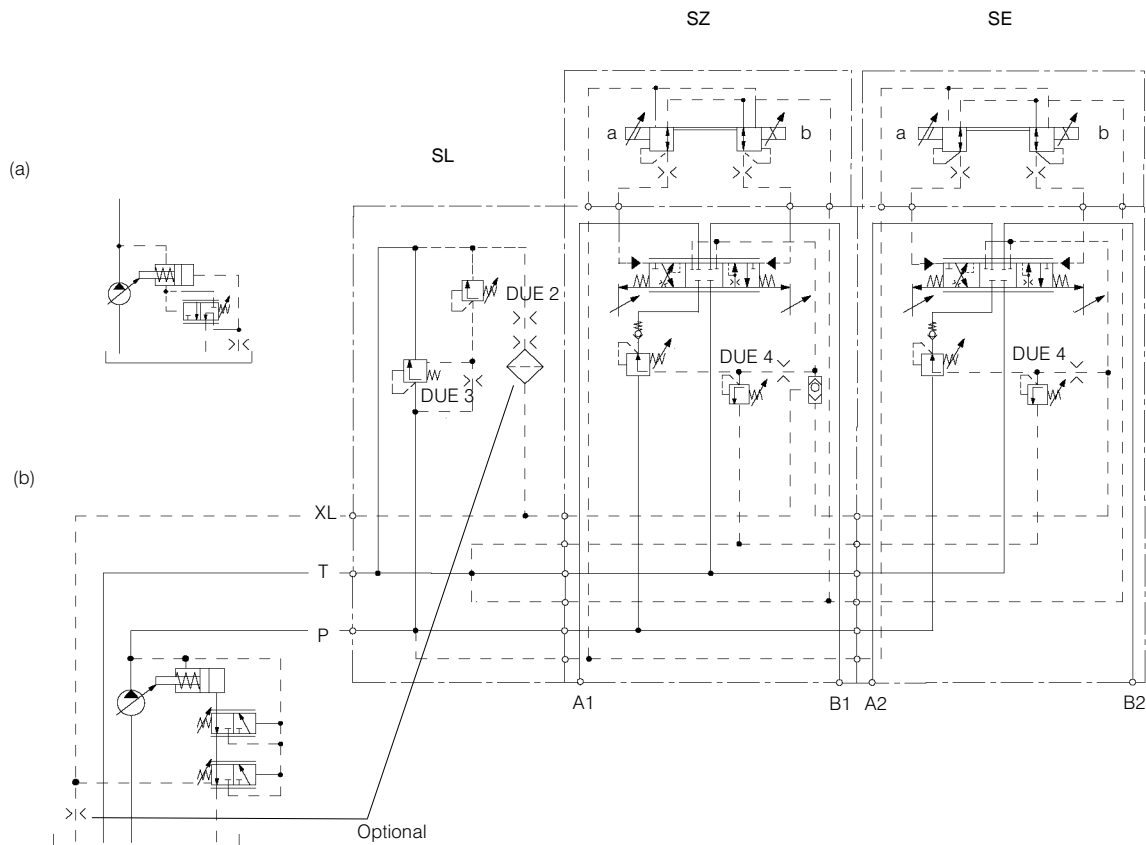

## 2. Description of the valve sections

### 2.1 SU, SO/SF and SL pump connection modules

#### 2.1.1 SU pump connecting module

The SU pump connecting module consists of a pressure compensator and a pressure relief valve as a pilot unit. When actuators are operated, the SY, SZ, SD and SE actuator modules send the load signal with the maximum pressure to the pressure compensator. The compensator preloads the delivery flow coming from the pump in accordance with this load signal, so that an

adequate system pressure is available to all directional control valve sections (SY, SZ, SD and SE) irrespective of changing loads. The excess pump delivery flow returns to the tank. If the permissible system pressure is exceeded by the load signal, the pressure relief valve opens and the pressure compensator operates as the main stage of the

pressure relief system, i.e. the delivery flow from the pump is fed to the tank.

If no load signal is being applied to the pressure compensator because no directional control valve is connected to the actuator, the pressure compensator feeds the delivery flow from the pump back to the tank under as good as no pressure at all.

Application: see section 1.1.1, page 3

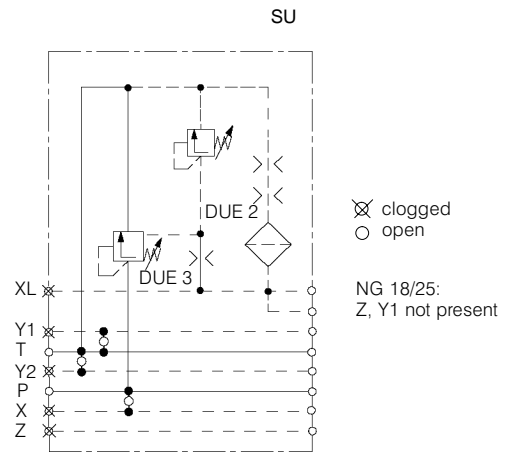
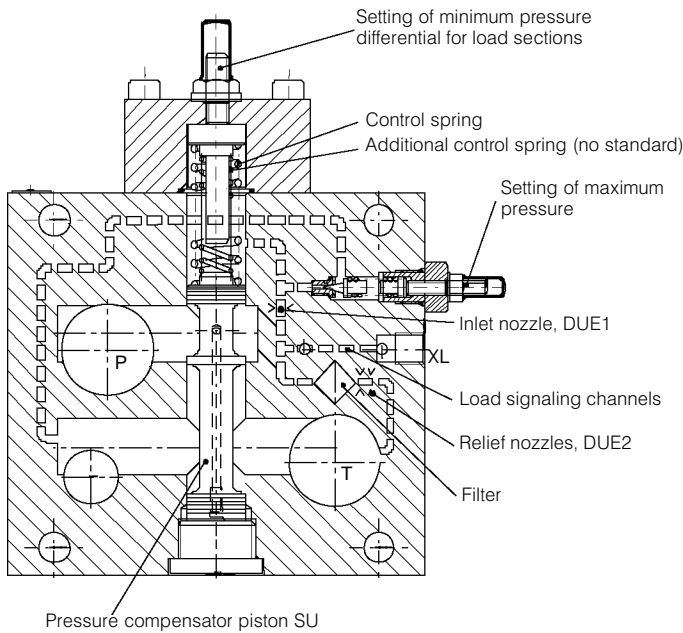

### 2.1.2 SO/SF pump connecting module

The SO pump connecting module serves purely as a connecting plate. It has no influence on the actuator modules downstream of it. Load signal port XL generates the load check-back signal sent to the variable displacement pump in load-sensing systems.

Alternatively, the load on the load signaling channel can be relieved in the pump regulator or in the SF pump connecting module.

SO pump connecting module:  
without relief nozzles

SF pump connecting module:  
with relief nozzles

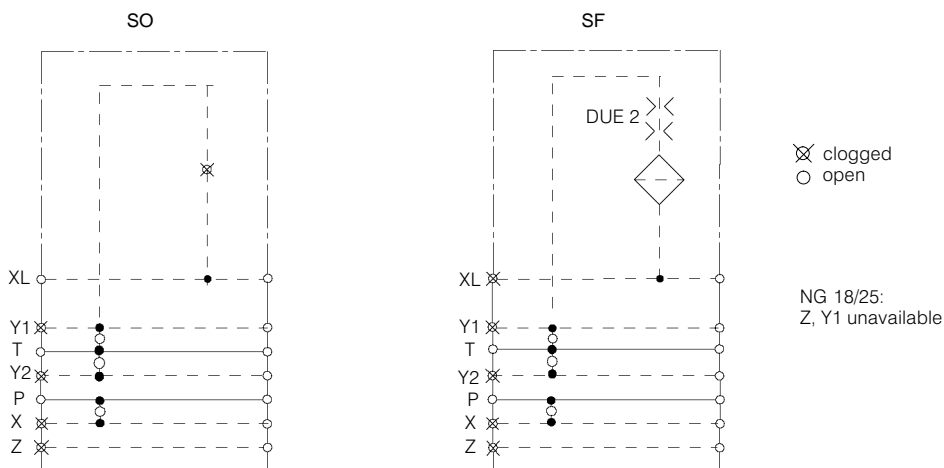

### 2.1.3 SL pump connecting module

The SL pump connecting module comprises a pilot-controlled pressure relief valve for protecting the control pump against impermissibly high pressures.

Load signal port XL generates the load check-back signal sent to the variable displacement pump in load-sensing systems. An appropriate nozzle combination is provided to relieve the load on the pump regulator when the proportional valves are not operated.

nation is provided to relieve the load on the pump regulator when the proportional valves are not operated.

Application: see section 1.2.2, page 5

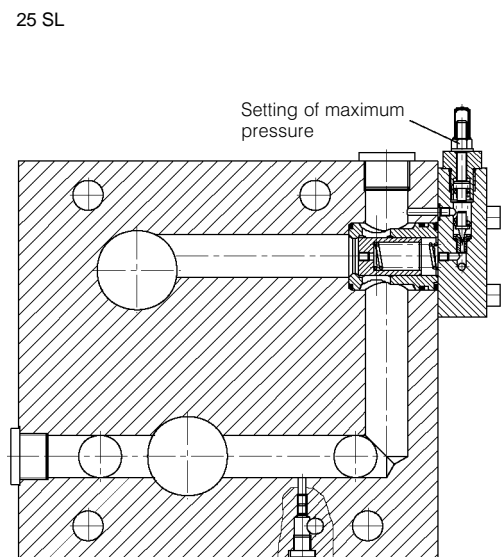
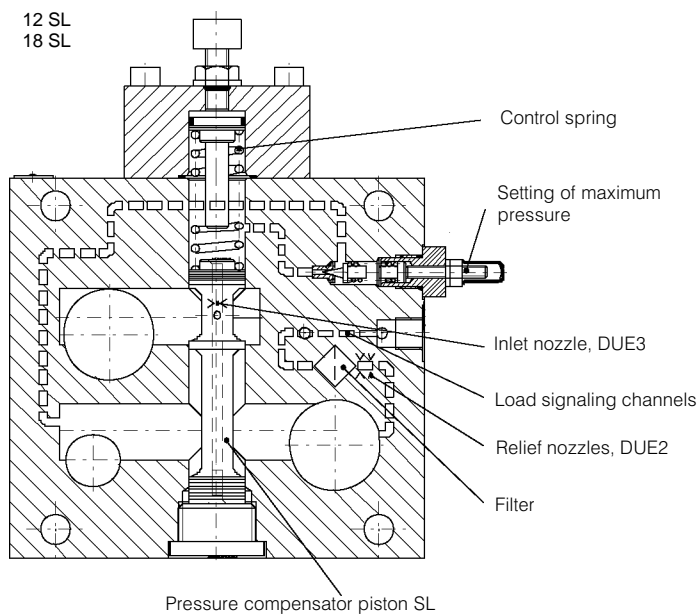
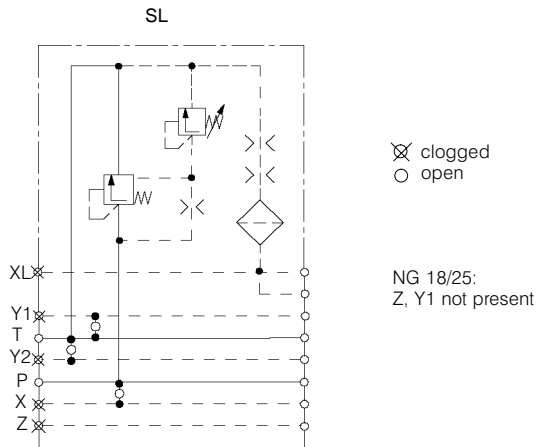

## 2.2 SY, SZ, SD and SE actuator modules

Each of these modules comprises a proportional directional control valve and a 2-way pressure compensator that, in conjunction with a pilot-controlled pressure relief valve, also serves to protect against overpressure.

The proportional directional control valves can be equipped with various versions of piston, as described in section 6.3, page 19. The metering edges of the main control piston are adapted individually for the respective application. This makes it possible to operate asymmetrical actuators, such as differential cylinders, at the same maximum speed in both directions of travel making full use of the stroke of the proportional val-

ves control piston. The 2-way pressure compensator performs a number of functions. When the proportional valve is actuated, a connection is made between actuating port A or B and the spring cavity of the pressure compensator by means of the internal load check-back signaling device. It is in this way that the flow control function of the actuator module is initiated. If the load pressure exceeds the value set at the pilot-controlled pressure relief valve, the pressure compensator piston acts as a pressure reducing valve. This stops the flow from the pump to the actuator.

Return flow of the pressure fluid from A/B - P can be prevented by means of a check valve that is integrated in the pressure compensator (SZ and SE actuator modules).

In particular, the check valve is not required when load holding valves (load control valves for lowering, pilot-controlled check valves) are used; actuator modules SY and SD must then be used. The advantages of module types SY and SD here are the low pressure losses in the valves themselves and the higher maximum possible flow rate through the valves (see figure 2.2.2, page 9).

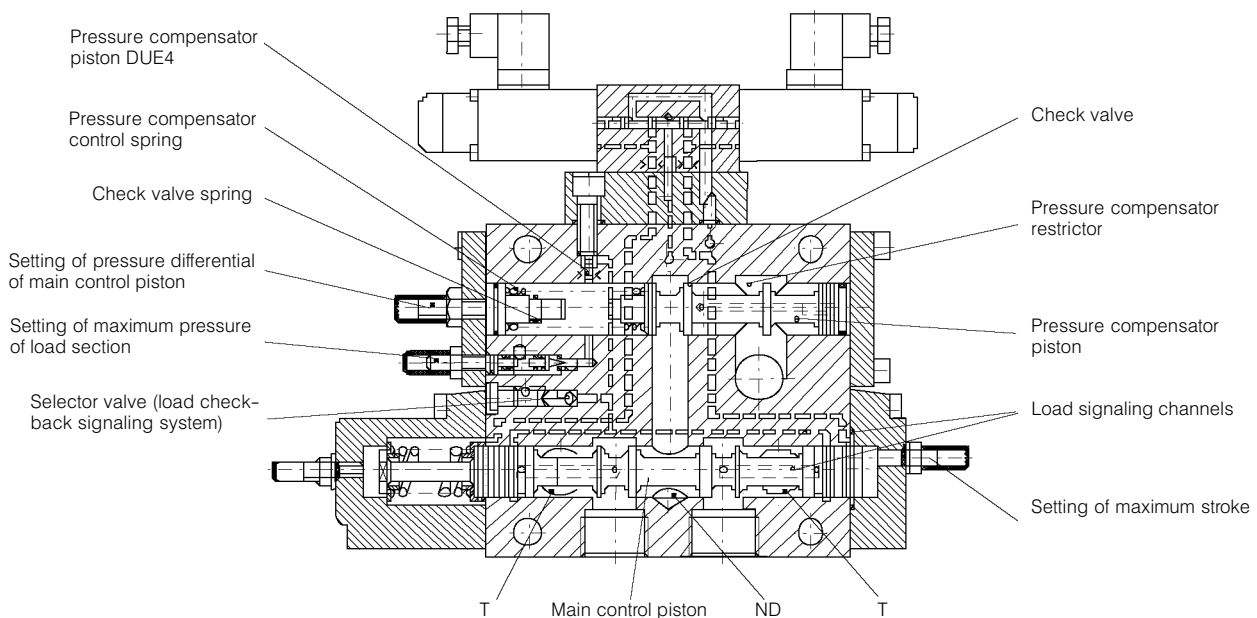

2.2.1 Figure

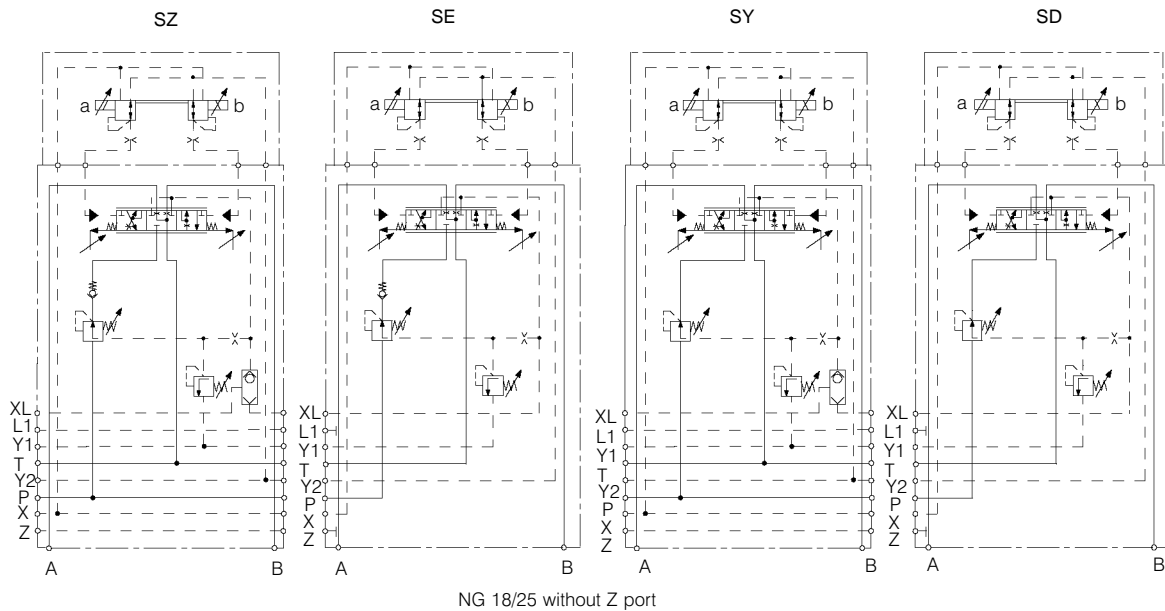

2.2.2 Figure: Flow characteristics with maximum displacement of main control piston

	Q [%]	NG 12	NG 18	NG 25
		Q [l/min]	Q [l/min]	Q [l/min]
SZ, SE	100	95	190	450
SY, SD	100	106	210	500

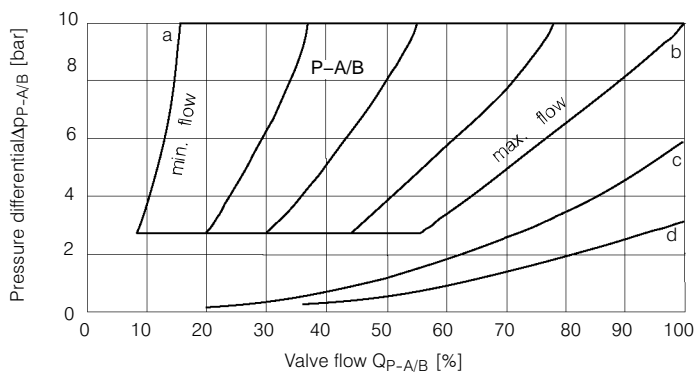

The volumetric flow rates quoted are guidelines. They depend on a great number of parameters and must be determined on a case by case basis.

a) Connection P - A/B with minimum cross-section

b) Connection P - A/B with maximum cross-section

c) Connection A/B - T (piston model A)

Connection A - T (piston model D, F, L)

Connection B - T (piston model B, G, K)

d) Connection A/B - T (piston model C)

Connection A - T (piston model B)

Connection B - T (piston model D)

The main control pistons can be manufactured with different cross sections of opening to suit the particular application (in addition to different piston symbols). The chart shows the limits of application.

### 3. Actuating methods

All common methods of actuation can be used with the actuator modules – manual, hydraulic, electrical and combinations of these.

#### 3.1 Manual actuation

##### 3.1.1 Actuation H6

The housing of the manual actuation unit is pressure-tight up to 50 bar.

The lever length required when the valve piston is in the neutral position must be specified when ordering (see

section 6.2, p. 18). The main control piston and the actuating element are held in the neutral position by a spring-loaded centering mechanism.

The actuating force increases as the displacement increases.

##### 3.1.2 Manual actuation with electrical switching contacts S1...S4

This actuating method is similar to H6 actuation, but is equipped with electrical switching contacts that serve to ac-

tivate and deactivate additional and auxiliary functions (valves, drives, relays etc.). Normally closed, normally

open and changeover contacts can be implemented.

##### 3.1.3 Manual actuation with positional locking and friction H7

With this actuating method, the main control piston is not springcentered.

#### 3.2 Hydraulic actation

In unactuated state, the main control piston is held in neutral position by a centering spring. When pressure is applied to control channels a, X/b and Y

(see figure 1.1.1, p. 3), the main control piston is displaced proportional to the control pressure differential applied.

Manually actuated, hydraulic pilot devices are used to generate the control pressure differential.

#### 3.3 Electrical actuation E1/E2/M2(M1)/M3(M4)

An electrically and proportionally actuated pressure regulator serves as a pilot valve, the pressure as standard being supplied to it internally from the pump channel. The return line is connected internally to the tank channel. An external supply of control oil and return to the tank is also available as an option.

The main control piston is spring-centered and is displaced proportional to the electrical control current by the control pressure differential regulated by the pilot valve (see control pressure characteristics, figure 3.3.1, p.11). The supply and return of control oil requires the following minimum pressure differentials between the pump and tank ports or between the external ports: 8

bar for opening and 20 bar for full displacement of the main control piston. The electrical control current is converted to a control pressure differential by proportional solenoids that continue displacing the pilot piston until an equilibrium of forces is achieved at the pilot piston between the magnetic force and the control pressure differential.

### 3.3.1 Figure: Transient function

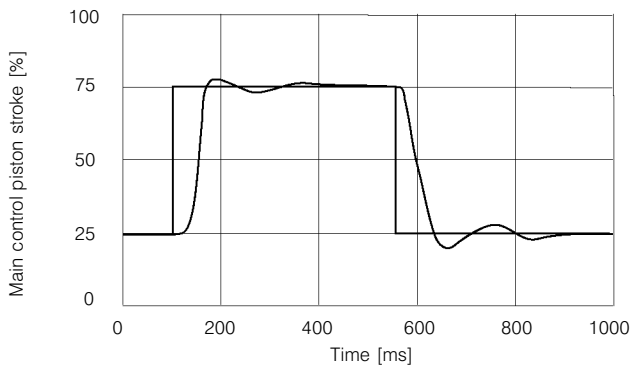

Transient function with stepped electrical input  $50\% \pm 25\%$ .

## 3.4 Combined actuation

### 3.4.1 Hydraulic/manual HO

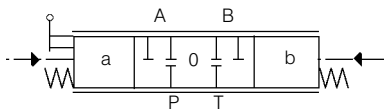

Priority is given to manual actuation when the actuating forces require this.

### 3.4.2 Electrohydraulic/manual K...

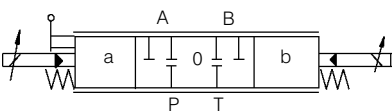

Priority is given to manual actuation when the actuating forces require this.

### 3.4.3 Electrohydraulic/hydraulic Y.. / B..

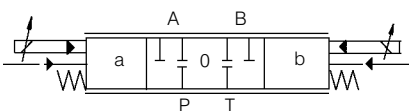

With this combination, the actuating method that is active is always that with the greatest control pressure differential.

## 4. Additional functions

In addition to the standard valve versions described in sections 1 to 3, there are numerous additional functions

available for customizing systems to the particular requirements for the control tasks to be solved.

Section 4 provides an overview of the most important of these additional functions. More detailed information is available on request.

### 4.1 Pressure reduction (control-oil supply)

If necessary, this SX end module makes it possible to do without a separate control-oil pump, e.g. for supplying hydraulic control pressure sensors or for actuating hydraulic braking (load con-

trol) equipment. The necessary pressure regulator with downstream pressure protection is integrated into a flange-mountable housing (see figure 4.2.1, p. 13). When there is an internal

connection to the actuator modules via port X, the P - X connection in the pump connecting module must be interrupted.

4.1.1 Figure:

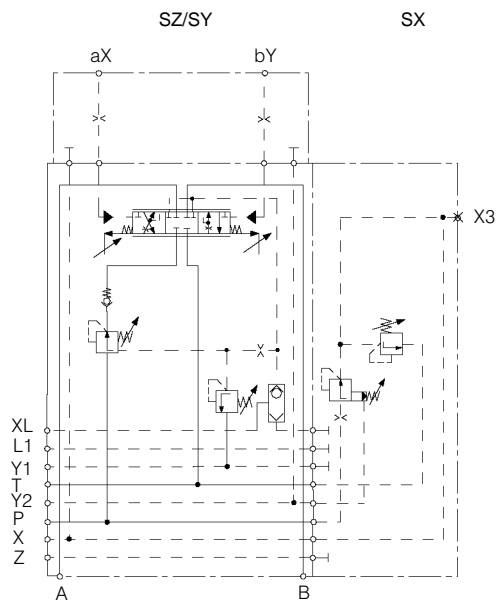

#### 4.2 Actuator flow reduction (AVR)

The load-independent operating mode of a load-sensing control system no longer functions if the pump delivery flow is no longer sufficient to cover the requirements of the actuators. The supply of oil to the actuator operating with the highest load pressure then breaks down.

This problem can be remedied by Bucher's AVR system (AVR = Automatic

Volumetric flow Reduction) with an SX end module (see figure 4.2.1, p. 13).

This system automatically reduces the amount of valve displacement if the sum of the actuator flows begins to exceed the pump delivery flow available. This error in the volumetric flow balance is detected by the AVR pressure regulator and transferred to the pilot pressure of the proportional directional control

valves by reducing the control pressure preset by means of the pilot valves. First, the AVR system reduces the highest control pressure that arises and, in the process, the control section of the proportional directional control valve that is open to the greatest extent, too. If necessary, the next-highest control signals are reduced until the actuator flows and pump flows are balanced.

4.2.1 Figure:

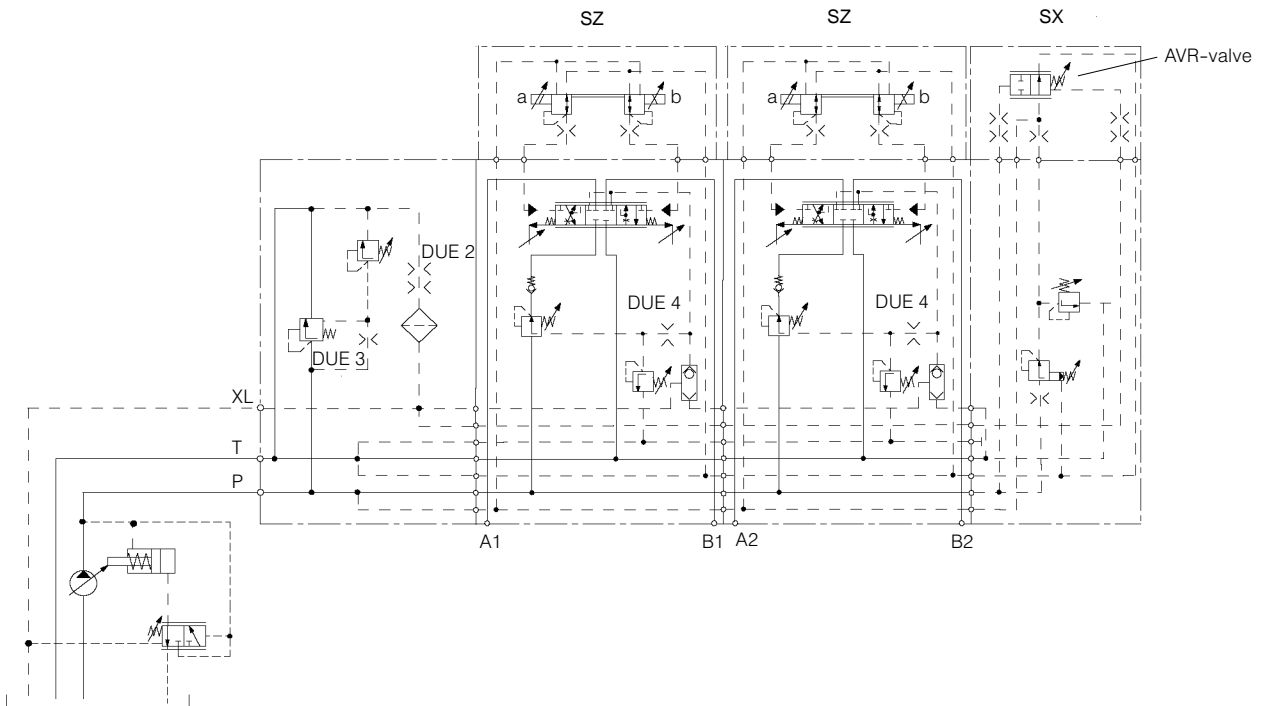

**4.3 Adapter plate for combining different nominal sizes of valve**

It is also possible to combine valve systems with greatly differing actuator flows using an SM adapter module. This option enables both costs and weight to be reduced.

**4.4 Actuator pressure protection separated on A and B sides**

A further option is that of different pressure protection for the actuator ports A and B. With this additional function, separate pilot pressure relief valves are fitted in the SY, SZ, SD and SE actuator modules for ports A and B. If the load pressure exceeds the values set at the pilot valves, the pressure compensator piston acts as a pressure reducing valve.

It must be noted that the pressure at port B can only be set to a value lower than that at port A (see figure 4.4.1).

4.4.1 Figure:

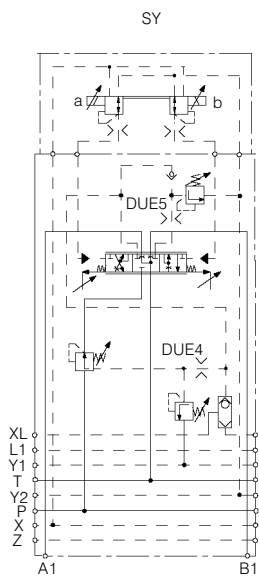

## 5. Sizes

### 5.1 General

Design	all functions: slide valve pilot relief valve: seat valve
Actuation	electrically actuated proportional, hydraulic, manual
Type of connection	company standard: see sec. 7., p. 19 for connecting thread
Installation position	any
Weight of pump connection modules	see table 5.1.1, p. 14
Weight of actuator modules SZ, SE	see table 5.1.2, p. 15
Ambient temperature	-30 ... 60°C
Hydraulic medium	mineral oil per DIN 51524 and DIN 51525 (HL/HLP)
Recommended pressure fluid temperature	20 ... 60°C
min. temperature	-20°C
max. temperature	+80°C
	Other temperature – contact Bucher
Recommended viscosity range	15 ... 100 mm <sup>2</sup> /s
min. viscosity	10 mm <sup>2</sup> /s
max. viscosity	380 mm <sup>2</sup> /s
Filtering/purity class	see table 5.1.3, p. 15
Max. working pressure	
Port P/A/B	... 350 bar
T port	... 50 bar
Max. pump delivery flow	NG 12: 200l/min. NG 18: 400l/min. NG 25: 900l/min.
Nominal flow	NG 12: 95 (105)l/min. NG 18: 190 (210)l/min. NG 25: 450 (500)l/min.
Flow characteristics	see figure 2.2.2, p. 9

5.1.1 Table: Weight of pump connecting modules [kg]

	NG 12	NG 18	NG 25
SU	5.4	12.2	26.5
SL	5.4	12.2	26.5
SO / SF	4.4	10.3	26.5

5.1.2 Table: Weight of actuator modules SZ and SE [kg]

		NG 12	NG 18	NG 25
H6	manual actuation	5.8	13.0	-
H7	man. actuation w. friction and positional locking	6.1	13.7	-
Y0	hydraulic actuation	6.0	13.0	34.7
E1, E2 M2(M1), M3(M4)	electrical actuation	8.1	15.7	36.6
K0...K9	electrical/manual actuation	8.4	16.3	-
H0	hydraulic/manual actuation	6.3	14.1	-
Y1, Y2 B2(B1), B3(B4)	electrical/hydraulic actuation	11.0	18.6	39.5

5.1.3 Table: Standards for operational reliability and service life

ISO 4406	Class 18/15
NAS 1638	Class 9

## 5.2 Actuating methods

### 5.2.1 Manual

Max. actuating angle	approx. 20 degrees	
Actuating force		
neutral pos	NG 12:	1.4 daN
	NG 18:	2.2 daN
	NG 25:	-
max. control	NG 12:	4.2 daN
	NG 18:	6.6 daN
	NG 25:	-

### 5.2.2 Hydraulic

Control pressure range	6...18 bar
------------------------	------------

### 5.2.3 Electrohydraulic

#### 5.2.3.1 Proportional with 12 V and 24 V DC standard solenoids

Hysteresis v.E.	≤6 % (control with 70 - 100 Hz PWM signal)
Recovery time for control piston stroke 25 %-75 %	see chart (figure 3.3.1, p. 11)
Recommended dither freq.	70...100 Hz
Supply pressure (internal and external) for the pilot valve	20...350 bar (*)
Type of protection per DIN 40050	IP65
Cyclic duration factor	100 %
Insulation class	F
Max. ambient temperature	45°C

(\*) during the internal supply the circuit pressure has to be at least 8 bar in the resting position of the main spool valve

5.2.3.2 Table

Voltage type	DC voltage	
Rated voltage	12 V	24 V
Coil resistance at 20°C	4.9 Ω + 5 %	19.6 Ω + 5 %
Coil resistance at 60°C	5.67 Ω	22.7 Ω
Control current range for Q = 0...100 %	480 ... 1200 mA	260 ... 650 mA
Power input at max. valve displacement (coil resistance at 60°C)	8.2 W	9.6 W
Max. perm. current	1.9 A	0.95 A
Inductance (start of stroke...end of stroke)	0.07...0.13 H	0.29...0.55 H
Electrical connection	Power socket per DIN EN 175301-803 (DIN43650)	

5.2.3.3 Switching (ON/OFF) as explosion-proof version (intrinsically safe)

Type of protection per EG RL 94/9	 I M2 EEx ia I
Rated voltage	12 V
Making current	260 mA
Holding current	130 mA
Power input	
Switch-on	3.2 W
Holding	1.6 W
Solenoid certification	DMT 99 ATEX E 102

5.2.3.4 Proportional as explosion-proof version (intrinsically safe)

Type of protection per EG RL 94/9	 I M2 EEx ia I
Rated voltage	12 V
Control current range for Q = 0...100 %	90...270 mA
Power input at max. valve displacement	< 2 W
Solenoid certification	DMT 99 ATEX E 102

## 6. Type codes

### 6.1 Type codes with example for ordering

Input module	SV	12	-	SU	300	-			-			-	C	-	V4	-	Z...		
Adapter module (max. 7)	SV	12	-	SZ	090	-	E2	O	-	A	100	/	090	-	C	-	V4	-	Z...
End module	SV	12	-	SY	270	-	K2	V	-	C	030	/	050	-	C	-	-	-	Z...
	SV	12	-	SE	300	-	Y0	O	-	C	060	/	060	-	C	-	-	-	-

  

<b>Valve construction series</b>	
Sandwich-Valve	= SV
<b>Nominal size</b>	= 8,12,18,25
<b>Type of module</b>	
<b>Input module</b>	
Pump connecting module with 3-way pressure compensator (sec. 1.1.1, p. 3 and 2.1.1, p. 5), sizes 12 and 18 only. Size 25 on request.	= SU
Pump connecting module with no function (sec. 2.1.2, p. 6)	= SO
Pump connecting module with relief of the load signaling channel (sec. 2.1.2, p. 6)	= SF
Pump connecting module with pump pressure protection on behalf of the hydraulic pump against over pressure (sec.1.2.2, p. 5 and 2.1.3, p. 7)	= SL
<b>Adapter module</b>	
Actuator module without check valve in the 2-way pressure compensator (D2)	= SY
Actuator module with check valve in the 2-way pressure compensator (D1)	= SZ
Adapter module with special function (specification in plain text under additional details)	= SM
<b>End module</b>	
Actuator module without check valve in the 2-way pressure compensator (D2)	= SD
Actuator module with check valve in the 2-way pressure compensator (D1)	= SE
Adapter module with special function (specification in plain text under additional details)	= SX
<b>Pressure setting 50 ... 350 bar</b>	
Without pressure specification, factory-set to a max.	

<b>Additional details in plain text (examples)</b>
Z1 = Additional port XLA/XLB
Z2 = Alternatively int./ext. control oil supply, V7
<b>Variant number</b>
Manufacturer's code, not to be quoted when ordering
V... =
<b>Serial code</b>
C =
<b>Volumetric flow in l/min.at rated travel (stroke) of the main control piston</b>
.../ = Flow P - A
/... = Flow P - B
<b>Piston symbol (with SY, SZ, SD, SE)</b>
see section 6.3, p. 19
<b>Position of the hand lever</b>
(with manual actuation, otherwise 0), see section 6.2, p. 18
<b>Actuating method</b>
<b>Manual (size 12 and 18 only)</b>
H6 = Standard
H7 = Additionally with friction and positional locking
S1 = Additionally with 1 switch and 2 positions
S2 = Additionally with 2 switches and 2 positions
S3 = Additionally with 1 switch and 3 positions
S4 = Additionally with 2 switches and 3 positions
YO =
<b>Hydraulic</b>
<b>Electrohydraulic</b>
E1 = Proportional 12 V DC
E2 = Proportional 24 V DC
E7 = On-off 12 V DC
E8 = On-off 24 V DC
M2(M1) = Proportional (intrinsically safe) see Table 6.1.1, p. 18
M3(M4) = On-off (intrinsically safe) see Table 6.1.1, p. 18
M6(M5) = On-off (intrinsically safe) with cable end see Table 6.1.1, p. 18
<b>Electrohydraulic/hydraulic</b>
Y1 = Proportional 12 V DC
Y2 = Proportional 24 V DC
Y7 = On-off 12 V DC
Y8 = On-off 24 V DC
B2(B1) = Proportional (intrinsically safe) see Table 6.1.1, p. 18
B3(B4) = On-off (intrinsically safe) see Table 6.1.1, p. 18
B6(B5) = On-off (intrinsically safe) with cable end see Table 6.1.1, p. 18
<b>Elektrohydraulisch/manuell (size 12 and 18 only)</b>
K1 = Proportional 12 V DC
K2 = Proportional 24 V DC
K8(K5) = Proportional (intrinsically safe) see Table 6.1.1, p. 18
K9(K6) = On-off (intrinsically safe) see Table 6.1.1, p. 18
K0(K7) = On-off (intrinsically safe) with cable end see Table 6.1.1, p. 18
H0 = Hydraulic/manual (size 12 and 18 only)

6.1.1 Type code table

	Old-unit 30.06.03	New-from 01.07.03
Designation	EE ia I	 I M2 EEx ia I
Approval No.	BVS Nr. 85.1035	DMT 99 ATEX E 102
Electric proportional	M1	M2
ON/OFF	M4	M3
	M5*	M6*
Electro-hydraulic prop.	B1	B2
ON/OFF	B4	B3
	B5*	B6*
Electro-mech. prop.	K5	K8
ON/OFF	K6	K9
	K7*	K0*

\* on request only

6.2 Position of the hand lever

Manual type of actuation H6/H7/K/S  
Possible lever positions

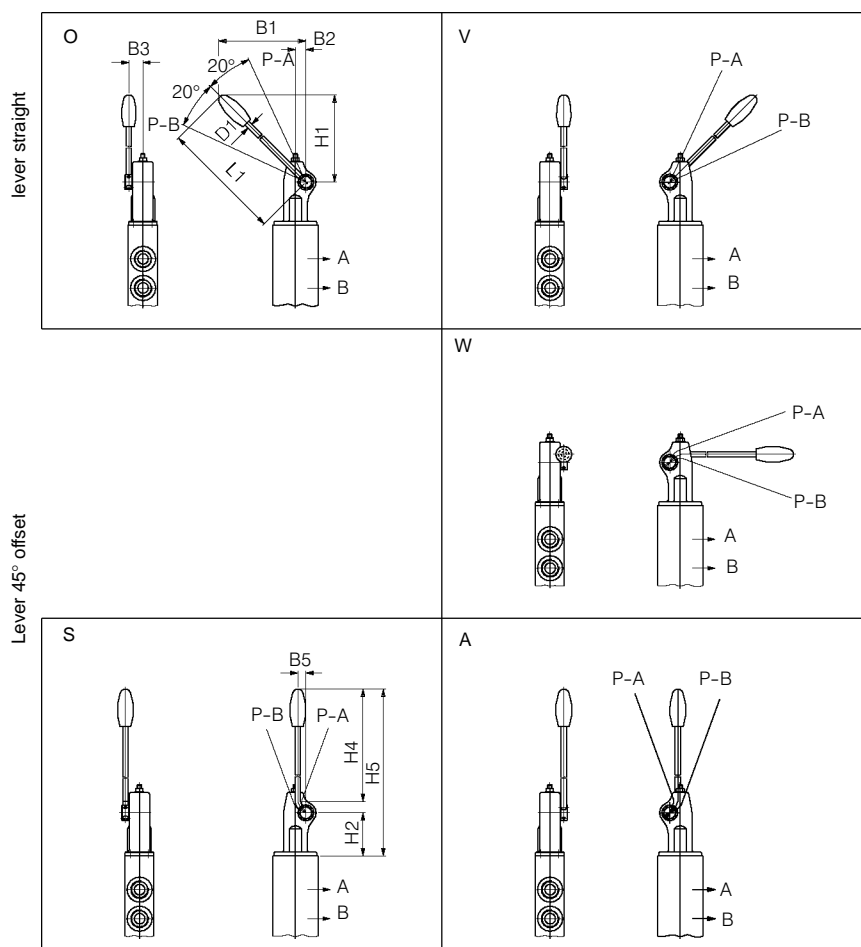

Dimensions

NG	B1	B2	B3	B4	B5	H1	H2	H3	H4	H5	H6	L1	L2
12	146	14	19.5	194	11.2	148	50.3	11.2	177	245	95	198	8
18	230.5	19.5	28	316	15	232	81.30	15	294	398	135	320	10

### 6.3 Spool symbols

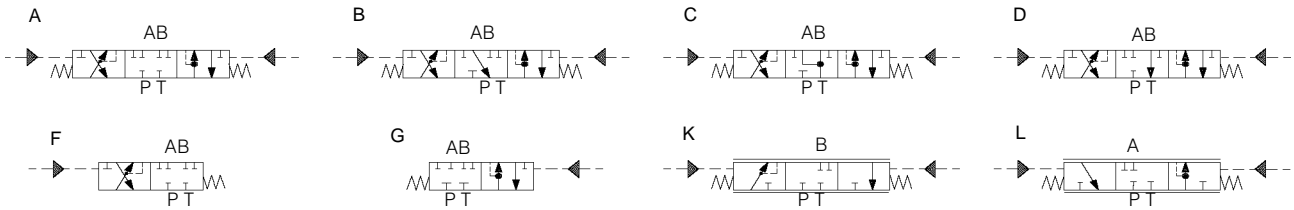

## 7. Dimensions

### 7.1 Pump connection modules (figures depict NG 12)

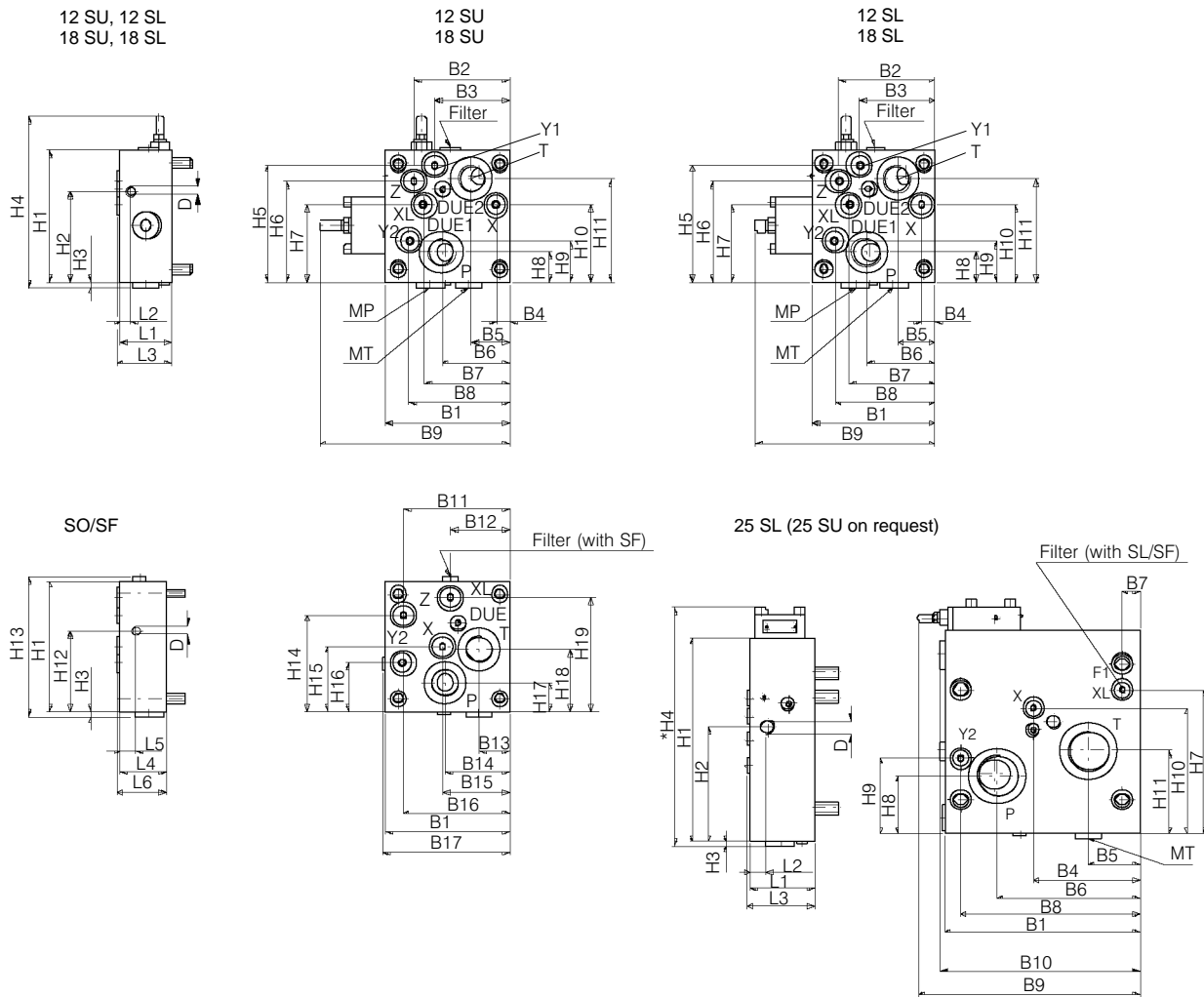

#### Dimensions

NG	L1	L2	L3	L4	L5	L6
12	50	10	54.5	45	15	49.5
18	63	10.5	67.5	55	12.5	59.5
25	75	20	79.5	-	-	-

NG	B1	B2	B3	B4	B5	B6	B7	B8	B9	B10	B11	B12	B13	B14	B15	B16	B17
12	122	95	74.5	13.5	37.5	67.5	85	99	188	177	104.5	85.3	30	64	66	105.5	125.5
18	165	-	-	104	49	97	124	129	239.5	228	-	81.5	44	89	130	142.5	169.5
25	230	-	-	125	60	167	20	210	260.5	234.5	-	-	-	-	-	-	-

NG	H1	H2	H3	H4	H5	H6	H7	H8	H9	H10	H11	H12	H13	H14	H15	H16	H17	H18	H19
12	130	90	4.5	169	116	100	76	29	41	76.5	102	80	138	96	65	48	29	62	113
18	180	112	4.5	219	-	-	118	43	15	134	141	112	189	-	108	68.5	45	131	161.5
25	240	135	4.5	280.5	-	-	170	68	89	148.5	97	-	-	-	-	-	-	-	-

Connecting thread

NG	P/T	MP	MT	X	XL	Y1	Y2	Z
12	G 3/4	G 1/2	G 1/2	G 1/4	G 1/4	G 1/4	G 1/4	G 1/4
18	G1 1/4	G 3/4	G 3/4	G 1/4	G 1/4	-	G 1/4	-
25	G1 1/2	-	G 3/4	G 1/4	G 1/4	-	G 1/4	-

Fastening thread

D
M8, 12 deep
M10, 15 deep
M16, 25 deep

## 7.2 Actuator modules with type of actuation H6 (Fig. NG 12, H6O)

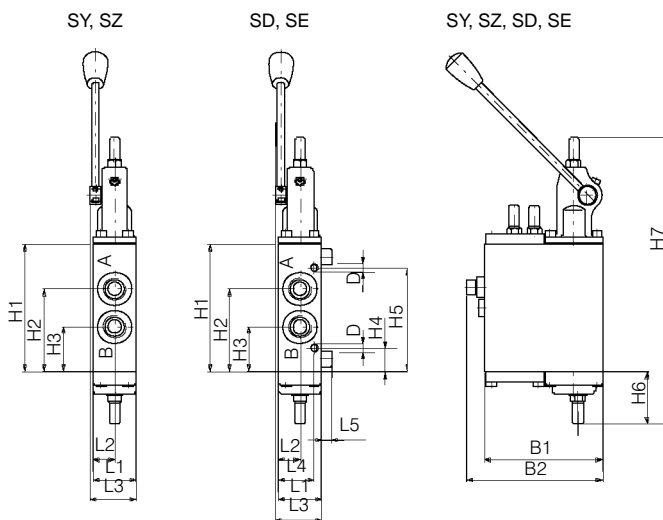

Connecting thread

NG	A/B
12	G 1/2
18	G1
25	G1 1/2

Fastening thread

D
M8, 12 deep
M10, 15 deep
M16, 25 deep

Dimensions

NG	L1	L2	L3	L4	*L5	H1	H2	H3	H4	H5	H6	H7	B1	B2
12	45	22.5	48	37	*10	130	84	46	24	106	53.5	292.3	122	140
18	55	27.5	60.5	27.5	*9	180	117	63	8	172	58.5	388.3	165	176.5
25	-	-	-	-	-	-	-	-	-	-	-	-	-	-

\* only for valves with more than 5 modules

**7.3 Actuator modules with type of actuation H7 (Fig. NG 12, H70)**

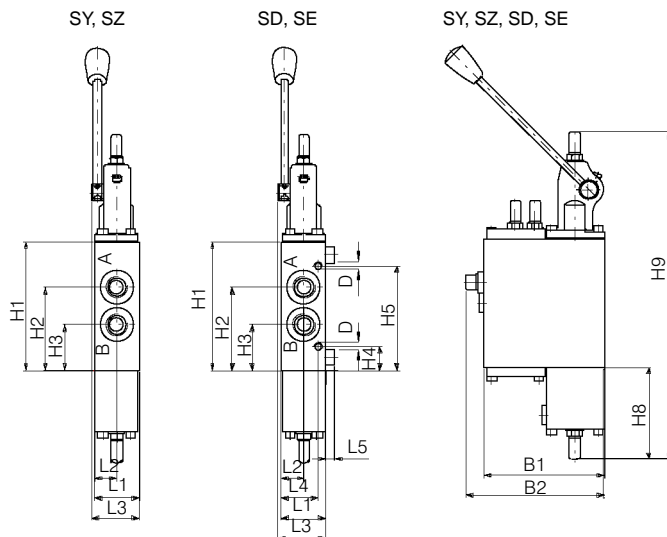

Connecting thread

NG	A/B
12	G 1/2
18	G1
25	G1 1/2

Fastening thread

D
M8, 12 deep
M10, 15 deep
M16, 25 deep

Dimensions

NG	L1	L2	L3	L4	*L5	H1	H2	H3	H4	H5	H8	H9	B1	B2
12	45	22.5	48	37	*10	130	84	46	24	106	93.7	332.5	122	140
18	55	27.5	60.5	27.5	*9	180	117	63	8	172	107.5	437.5	165	176.5
25	-	-	-	-	-	-	-	-	-	-	-	-	-	-

\* only for valves with more than 5 modules

**7.4 Actuator modules with type of actuation S1, S2, S3, S4 (Fig. NG 12, S10)**

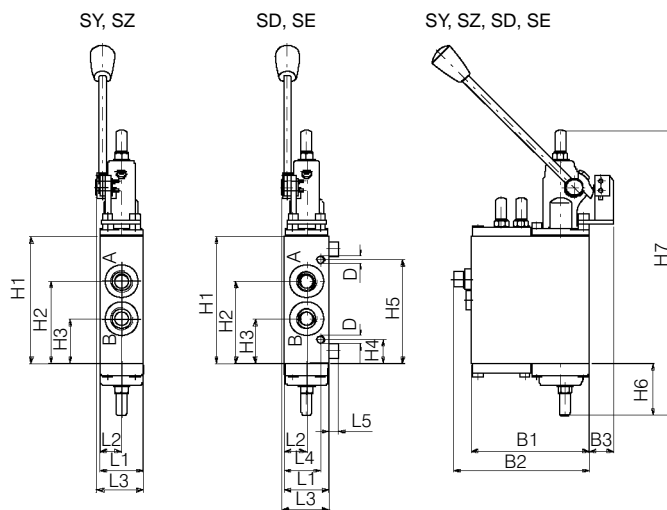

Connecting thread

NG	A/B
12	G 1/2
18	G1
25	G1 1/2

Fastening thread

D
M8, 12 deep
M10, 15 deep
M16, 25 deep

Dimensions

NG	L1	L2	L3	L4	*L5	H1	H2	H3	H4	H5	H6	H7	B1	B2	B3
12	45	22.5	48	37	*10	130	84	46	24	106	53.5	292.3	122	140	25
18	55	27.5	60.5	27.5	*9	180	117	63	8	172	58.5	388.3	165	176.5	25.5
25	-	-	-	-	-	-	-	-	-	-	-	-	-	-	-

\* only for valves with more than 5 modules

**7.5 Actuator modules with type of actuation H0** (Fig. NG 12, H00)

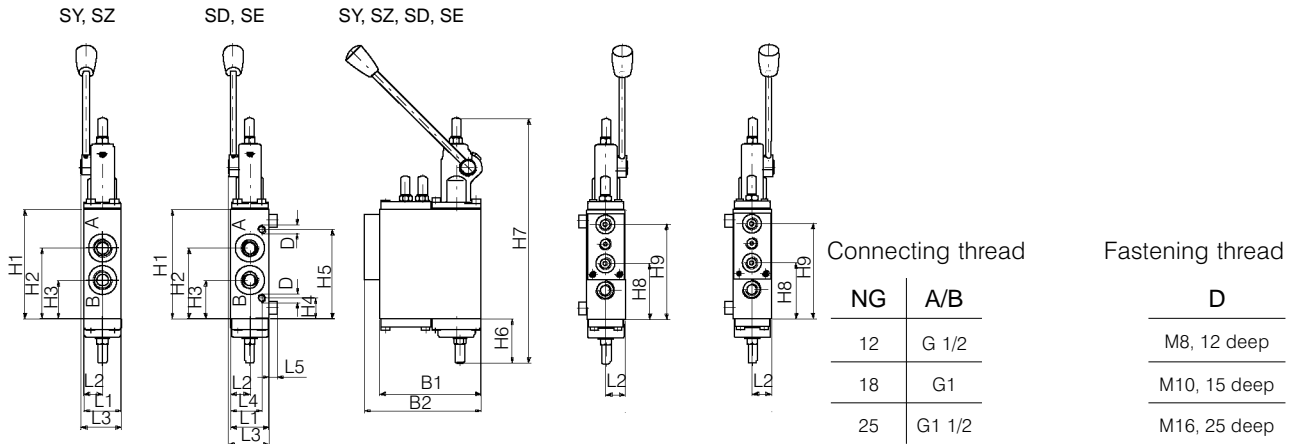

Dimensions

NG	L1	L2	L3	L4	*L5	H1	H2	H3	H4	H5	H6	H7	H8	H9	B1	B2
12	45	22.5	48	37	*10	130	84	46	24	106	53.5	292.3	62	108	122	140
18	55	27.5	60.5	27.5	*9	180	117	63	8	172	58.5	388.3	84	109	165	176.5
25	-	-	-	-	-	-	-	-	-	-	-	-	-	-	-	-

\* only for valves with more than 5 modules

**7.6 Actuator modules with type of actuation Y0** (Fig. NG 12)

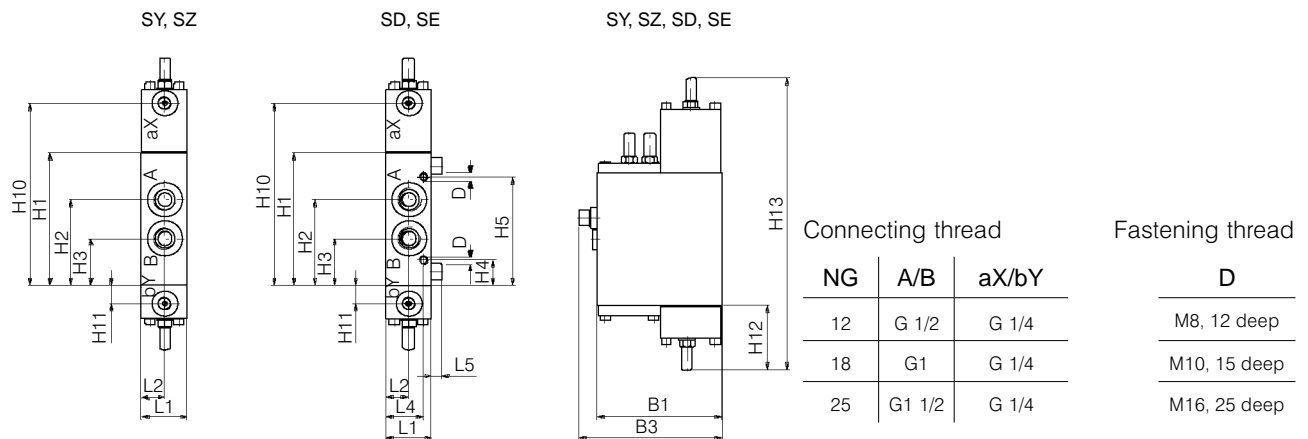

Dimensions

NG	L1	L2	L4	*L5	H1	H2	H3	H4	H5	H10	H11	H12	H13	B1	B3
12	45	22.5	37	*10	130	84	46	24	106	178.8	18.3	63.8	287.5	122	140
18	55	27.5	27.5	*9	180	117	63	8	172	237.3	13.3	59.8	347.6	165	176.5
25	75	37.5	45	*2	240	157	83	16	224	328	15	78	471	230	-

\* only for valves with more than 5 modules

**7.7 Actuator modules with type of actuation E1/E2 (Fig. NG 12)**

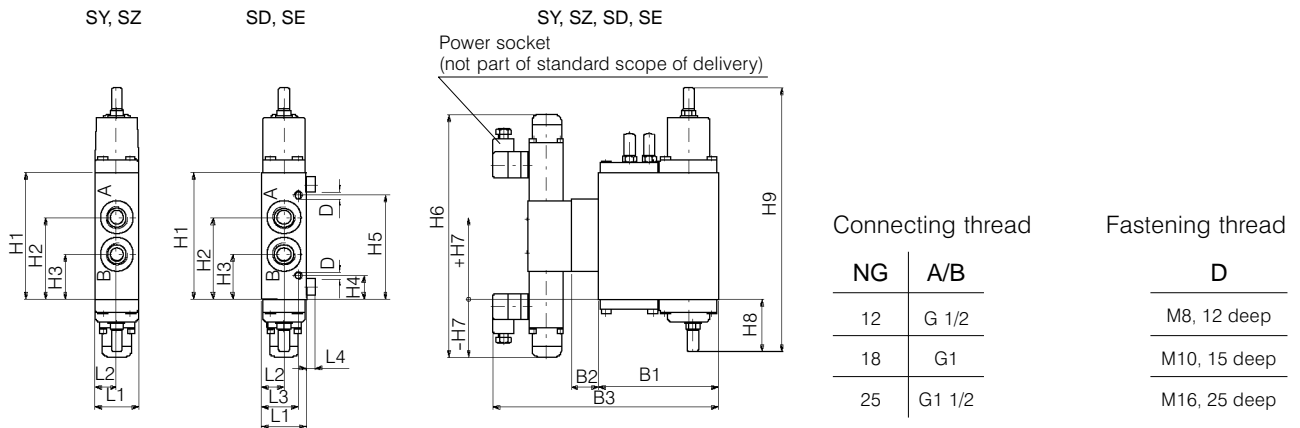

Dimensions

NG	L1	L2	L3	*L4	H1	H2	H3	H4	H5	H6	H7	H8	H9	B1	B2	B3
12	45	22.5	37	*10	130	84	46	24	106	app. 234	-52	53.5	270	122	28	230
18	55	27.5	27.5	*9	180	117	63	8	172	app. 234	-27	58.5	345	165	25	270
25	75	37.5	45	*2	240	157	83	16	224	app. 234	+74.5	78	471	230	-	310

\* only for valves with more than 5 modules

**7.8 Actuator modules with type of actuation E7/E8 (Fig. NG 12)**

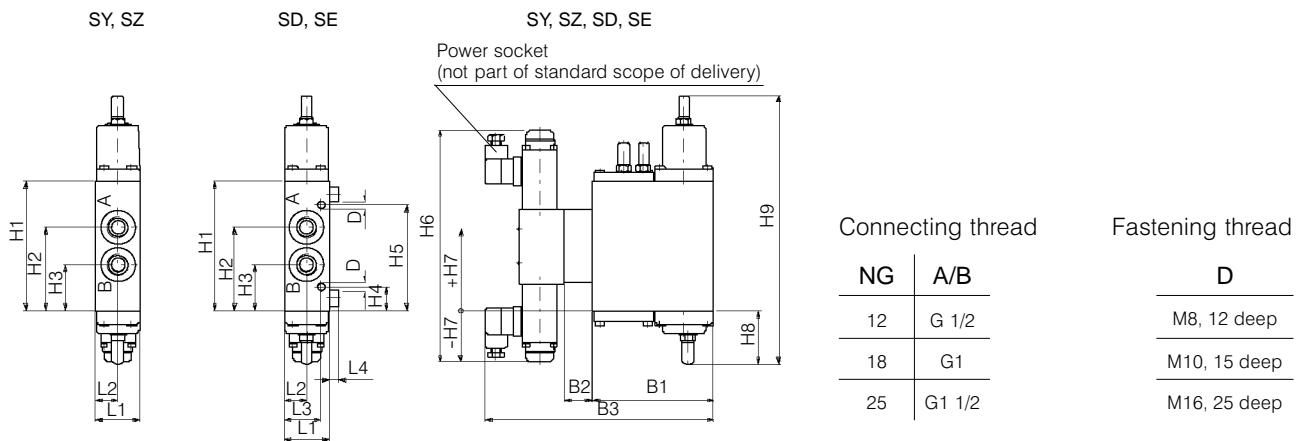

Dimensions

NG	L1	L2	L3	*L4	H1	H2	H3	H4	H5	H6	H7	H8	H9	B1	B2	B3
12	45	22.5	37	*10	130	84	46	24	106	234	-52	53.5	270	122	28	230
18	55	27.5	27.5	*9	180	117	63	8	172	234	-27	58.5	345	165	25	270
25	75	37.5	45	*2	240	157	83	16	224	234	+87.5	78	471	230	-	310

\* only for valves with more than 5 modules

**7.9 Actuator modules with type of actuation M2(M1) (Fig. NG 12)**

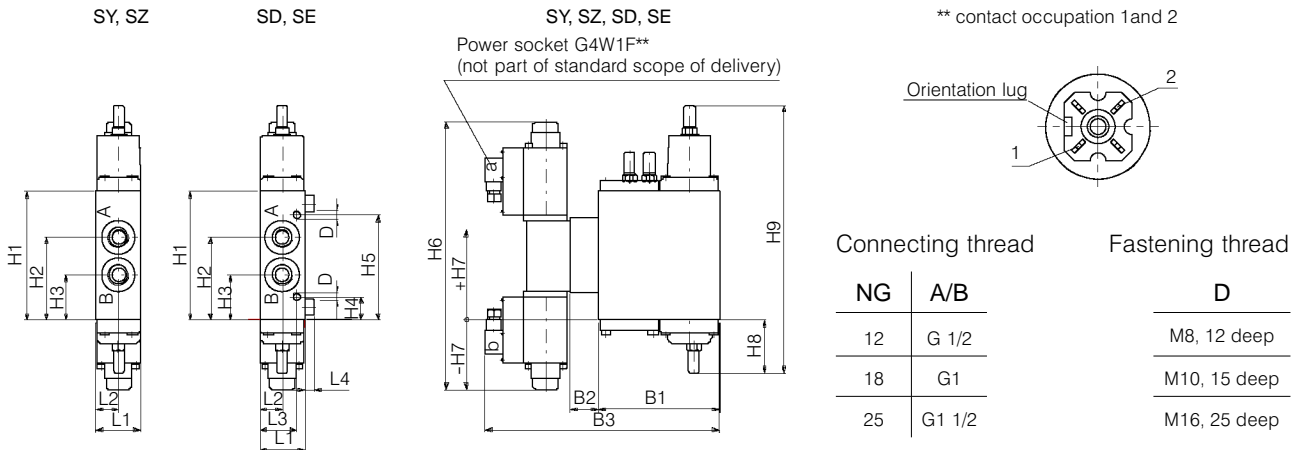

Dimensions

NG	L1	L2	L3	*L4	H1	H2	H3	H4	H5	H6	H7	H8	H9	B1	B2	B3
12	45	22.5	37	*10	130	84	46	24	106	270	-70	53.5	270	122	28	236
18	55	27.5	27.5	*9	180	117	63	8	172	270	-45	58.5	345	165	25	276
25	75	37.5	45	*2	240	157	83	16	224	270	+69.5	78	471	230	-	316

\* only for valves with more than 5 modules

**7.10 Actuator modules with type of actuation M3(M4) (Fig. NG 12)**

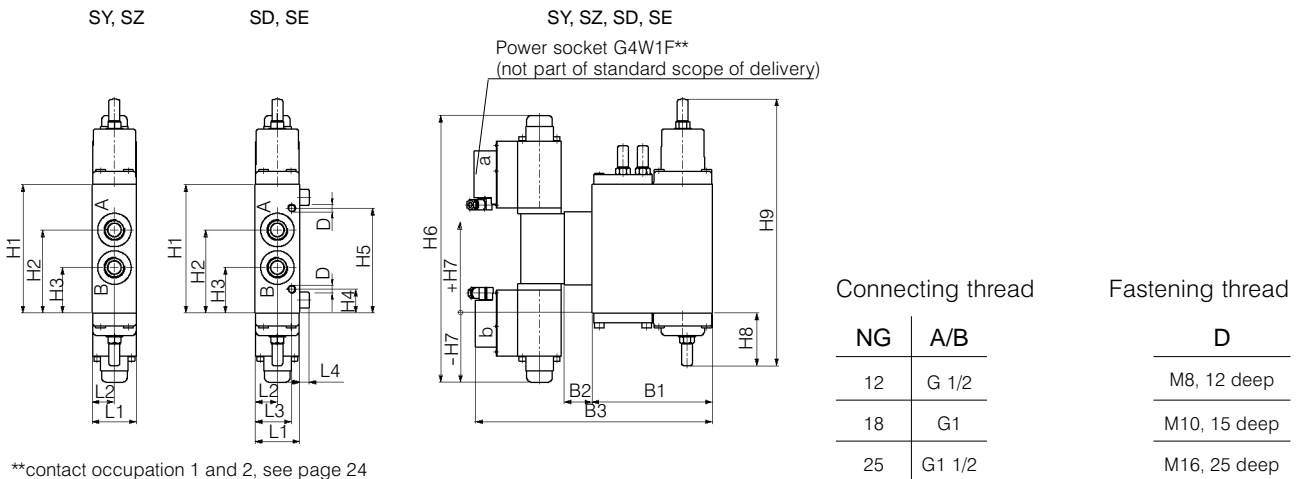

\*\*contact occupation 1 and 2, see page 24

Dimensions

NG	L1	L2	L3	*L4	H1	H2	H3	H4	H5	H6	H7	H8	H9	B1	B2	B3
12	45	22.5	37	*10	130	84	46	24	106	281	-75.5	53.5	270	122	28	238
18	55	27.5	27.5	*9	180	117	63	8	172	281	-50.5	58.5	345	165	25	278
25	75	37.5	45	*2	240	157	83	16	224	281	+64	78	471	230	-	318

\* only for valves with more than 5 modules

**7.11 Actuator modules with type of actuation M6(M5) on request only (Fig. NG 12)**

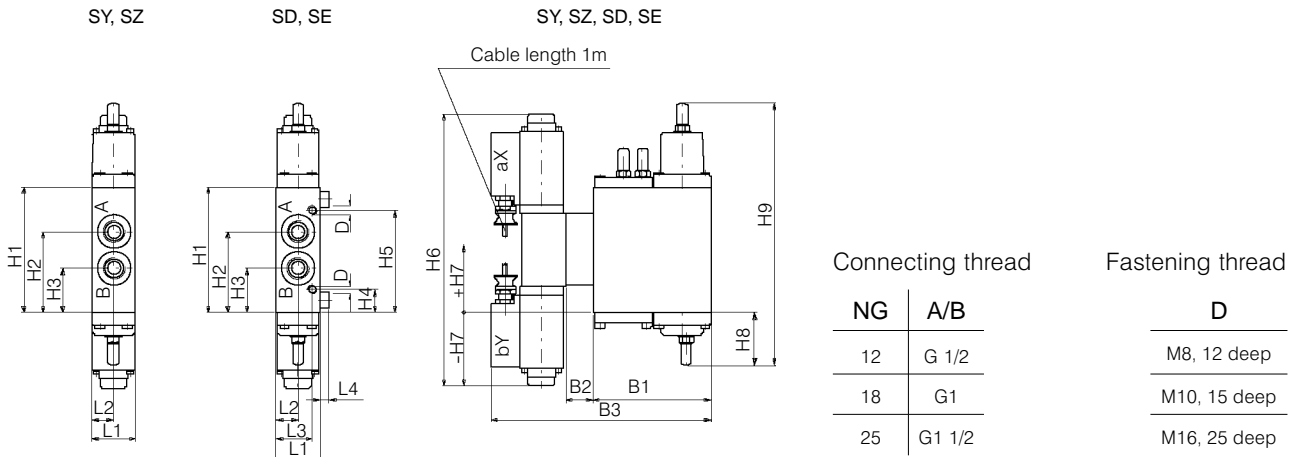

Dimensions

NG	L1	L2	L3	*L4	H1	H2	H3	H4	H5	H6	H7	H8	H9	B1	B2	B3
12	45	22.5	37	*10	130	84	46	24	106	281	-75.5	53.5	270	122	28	227
18	55	27.5	27.5	*9	180	117	63	8	172	281	-50.5	58.5	345	165	25	267
25	75	37.5	45	*2	240	157	83	16	224	281	+64	78	471	230	-	307

\* only for valves with more than 5 modules

**7.12 Actuator modules with type of actuation Y1/Y2 (Fig. NG 12)**

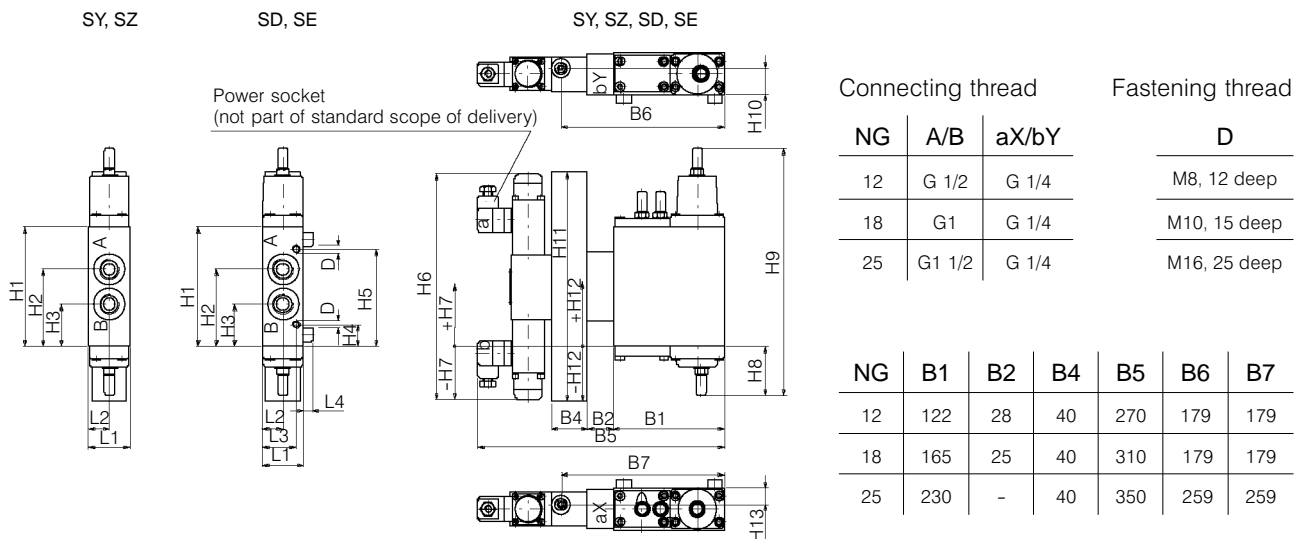

Dimensions

NG	L1	L2	L3	*L4	H1	H2	H3	H4	H5	H6	H7	H8	H9	H10	H11	H12	H13
12	45	22.5	37	*10	130	84	46	24	106	app. 234	-52	53.5	270	28.4	250	-60	17.5
18	55	27.5	27.5	*9	180	117	63	8	172	app. 234	-27	58.5	345	33.4	250	-35	22.5
25	75	37.5	45	*2	240	157	83	16	224	app. 234	+74.5	78	471	44.4	250	+79.5	33.5

\* only for valves with more than 5 modules

**7.13 Actuator modules with type of actuation Y7/Y8 (Fig. NG 12)**

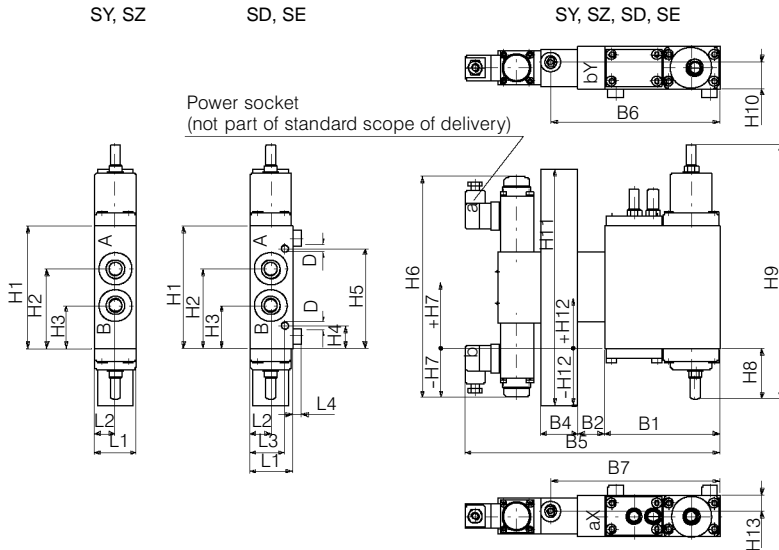

Connecting thread      Fastening thread

NG	A/B	aX/bY	D
12	G 1/2	G 1/4	M8, 12 deep
18	G1	G 1/4	M10, 15 deep
25	G1 1/2	G 1/4	M16, 25 deep

NG	B1	B2	B4	B5	B6	B7
12	122	28	40	270	179	179
18	165	25	40	310	219	219
25	230	-	40	350	259	259

Dimensions

NG	L1	L2	L3	*L4	H1	H2	H3	H4	H5	H6	H7	H8	H9	H10	H11	H12	H13
12	45	22.5	37	*10	130	84	46	24	106	234	-52	53.5	270	28.4	250	-60	17.5
18	55	27.5	27.5	*9	180	117	63	8	172	234	-27	58.5	345	33.4	250	-35	22.5
25	75	37.5	45	*2	240	157	83	16	224	234	+87.5	78	471	44.4	250	+79.5	33.5

\* only for valves with more than 5 modules

**7.14 Actuator modules with type of actuation B2(B1) (Fig. NG 12)**

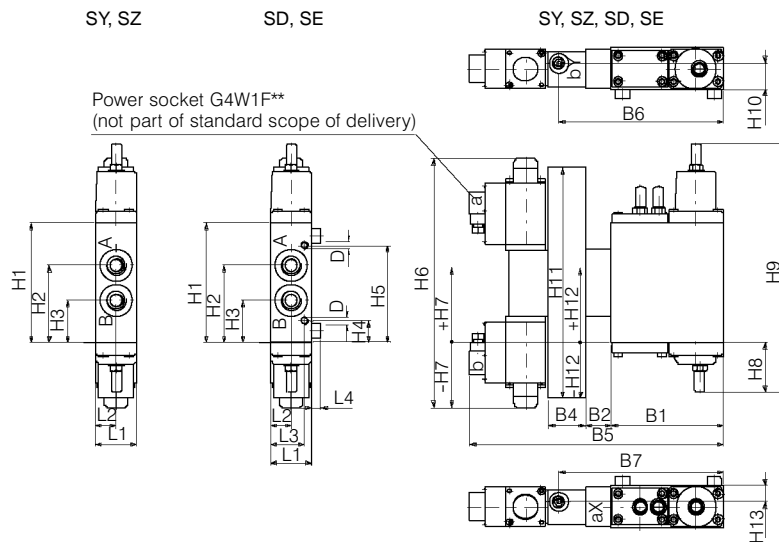

Connecting thread      Fastening thread

NG	A/B	aX/bY	D
12	G 1/2	G 1/4	M8, 12 deep
18	G1	G 1/4	M10, 15 deep
25	G1 1/2	G 1/4	M16, 25 deep

NG	B1	B2	B4	B5	B6	B7
12	122	28	40	276	179	179
18	165	25	40	316	219	219
25	230	-	40	356	259	259

\*\*contact occupation 1 and 2, see page 24

Dimensions

NG	L1	L2	L3	*L4	H1	H2	H3	H4	H5	H6	H7	H8	H9	H10	H11	H12	H13
12	45	22.5	37	*10	130	84	46	24	106	270	-70	53.5	270	28.4	250	-60	17.5
18	55	27.5	27.5	*9	180	117	63	8	172	270	-45	58.5	345	33.4	250	-35	22.5
25	75	37.5	45	*2	240	157	83	16	224	270	+69.5	78	471	44.4	250	+79.5	33.5

\* only for valves with more than 5 modules

**7.15 Actuator modules with type of actuation B3(B4) (Fig. NG 12)**

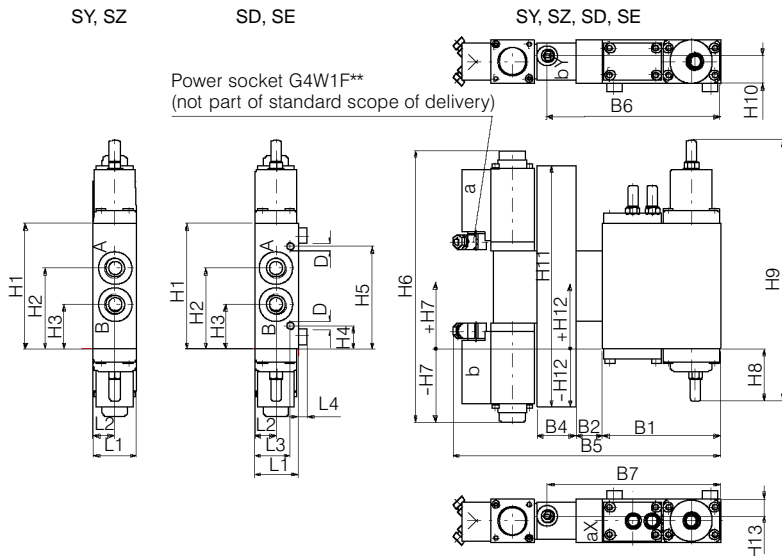

Connecting thread      Fastening thread

NG	A/B	aX/bY	D
12	G 1/2	G 1/4	M8, 12 deep
18	G1	G 1/4	M10, 15 deep
25	G1 1/2	G 1/4	M16, 25 deep

NG	B1	B2	B4	B5	B6	B7
12	122	28	40	278	179	179
18	165	25	40	318	219	219
25	230	-	40	358	259	259

\*\*contact occupation 1 and 2, see page 24

Dimensions

NG	L1	L2	L3	*L4	H1	H2	H3	H4	H5	H6	H7	H8	H9	H10	H11	H12	H13
12	45	22.5	37	*10	130	84	46	24	106	281	-75.5	53.5	270	28.4	250	-60	17.5
18	55	27.5	27.5	*9	180	117	63	8	172	281	-50.5	58.5	345	33.4	250	-35	22.5
25	75	37.5	45	*2	240	157	83	16	224	281	+64	78	471	44.4	250	+79.5	33.5

\* only for valves with more than 5 modules

**7.16 Actuator modules with type of actuation B6(B5) on request only (Fig. NG 12)**

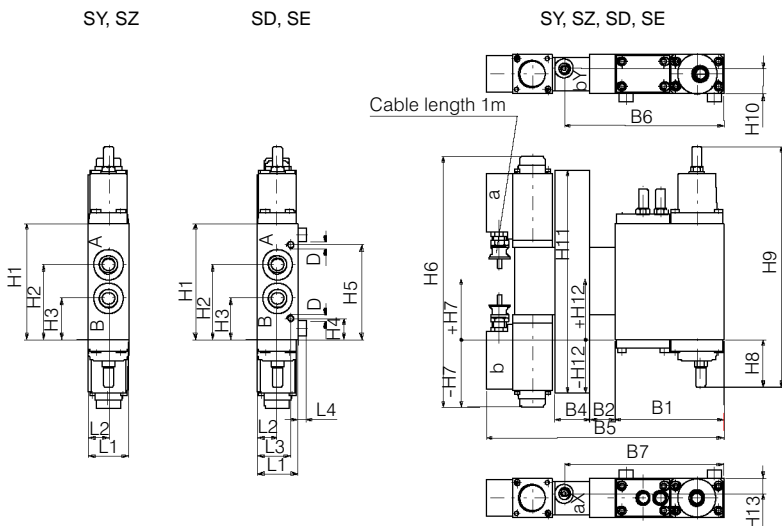

Connecting thread      Fastening thread

NG	A/B	aX/bY	D
12	G 1/2	G 1/4	M8, 12 deep
18	G1	G 1/4	M10, 15 deep
25	G1 1/2	G 1/4	M16, 25 deep

NG	B1	B2	B4	B5	B6	B7
12	122	28	40	267	179	179
18	165	25	40	307	219	219
25	230	-	40	347	259	259

Dimensions

NG	L1	L2	L3	*L4	H1	H2	H3	H4	H5	H6	H7	H8	H9	H10	H11	H12	H13
12	45	22.5	37	*10	130	84	46	24	106	281	-75.5	53.5	270	28.4	250	-60	17.5
18	55	27.5	27.5	*9	180	117	63	8	172	281	-50.5	58.5	345	33.4	250	-35	22.5
25	75	37.5	45	*2	240	157	83	16	224	281	+64	78	471	44.4	250	+79.5	33.5

\* only for valves with more than 5 modules

**7.17 Actuator modules with type of actuation K1/K2 (Fig. NG 12, K10/K20)**

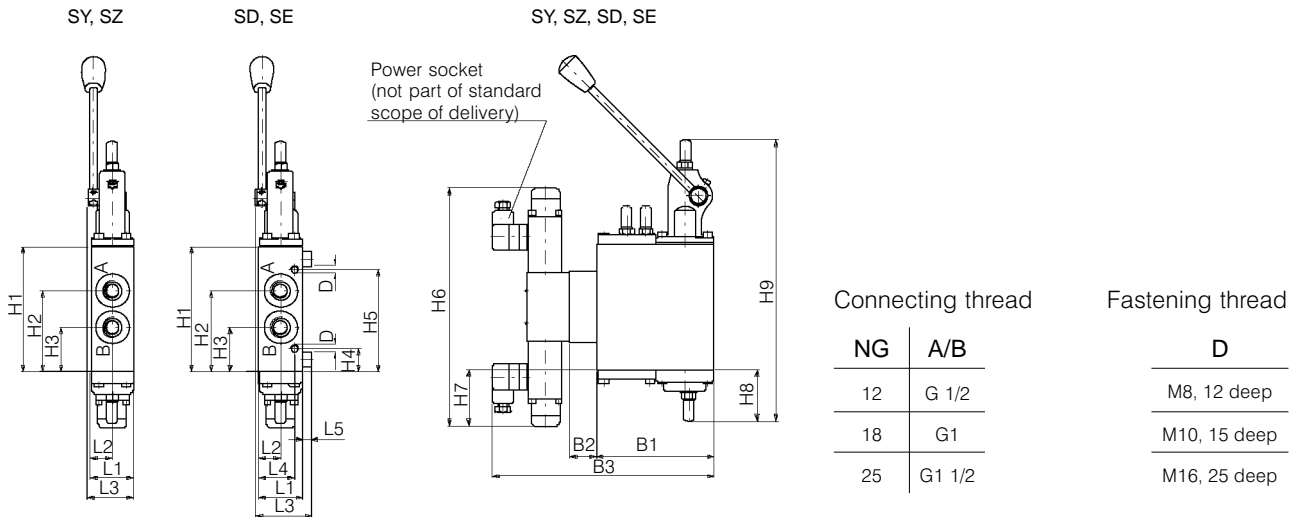

Dimensions

NG	L1	L2	L3	L4	*L5	H1	H2	H3	H4	H5	H6	H7	H8	H9	B1	B2	B3
12	45	22.5	48	37	*10	130	84	46	24	106	247	58.5	53.5	292.3	122	28	230
18	55	27.5	60.5	27.5	*9	180	117	63	8	172	247	33.5	58.5	388.3	165	25	270
25	-	-	-	-	-	-	-	-	-	-	-	-	-	-	-	-	-

\* only for valves with more than 5 modules

**7.18 Actuator modules with type of actuation K8(K5) on request only (Fig. NG 12, K80(K50))**

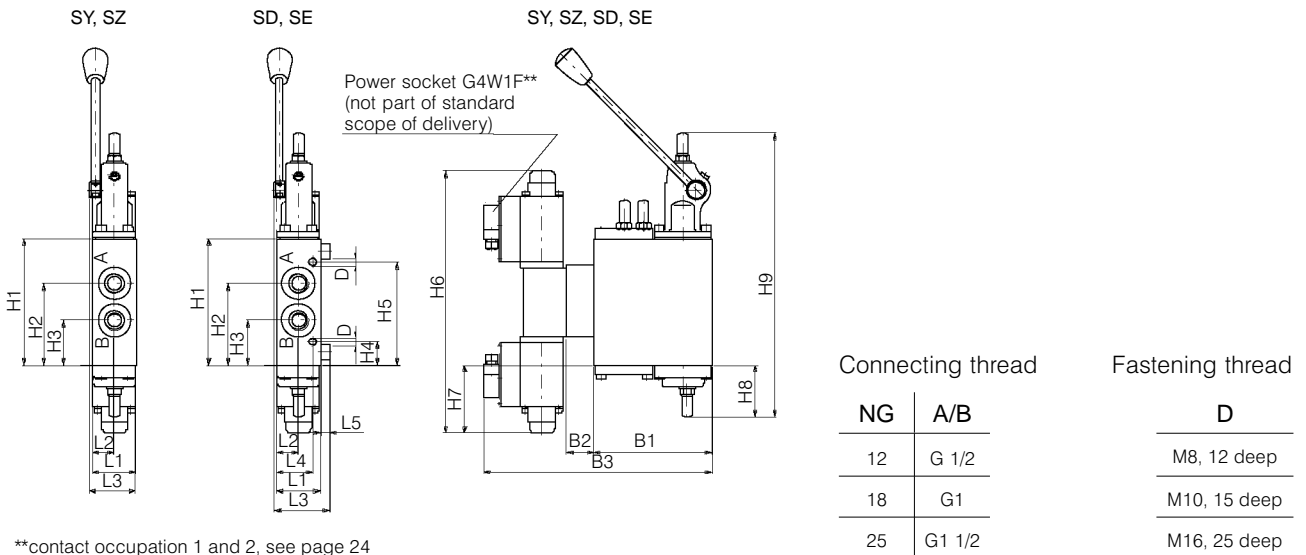

\*\*contact occupation 1 and 2, see page 24

Dimensions

NG	L1	L2	L3	L4	*L5	H1	H2	H3	H4	H5	H6	H7	H8	H9	B1	B2	B3
12	45	22.5	48	37	*10	130	84	46	24	106	270	70	53.5	292.3	122	28	236
18	55	27.5	60.5	27.5	*9	180	117	63	8	172	270	45	58.5	388.3	165	25	316
25	-	-	-	-	-	-	-	-	-	-	-	-	-	-	-	-	-

\* only for valves with more than 5 modules

**7.19 Actuator modules with type of actuation K9(K6)** (Fig. NG 12, K90(K60))

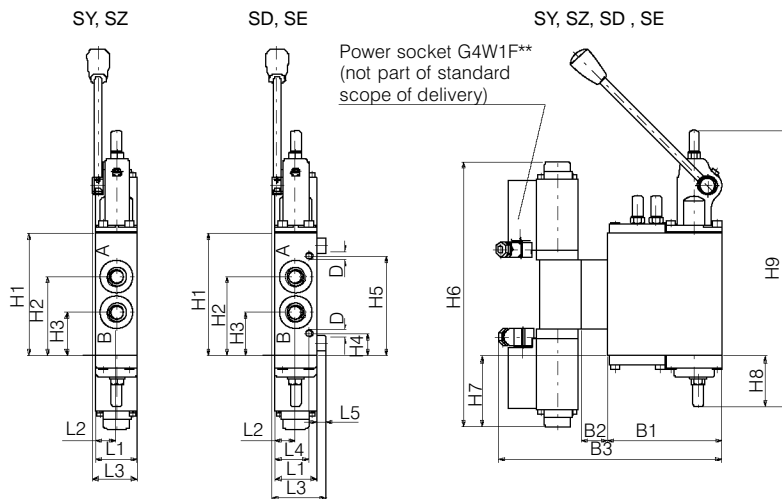

\*\*contact occupation 1 and 2, see page 24

Connecting thread

NG	A/B
12	G 1/2
18	G1
25	G1 1/2

Fastening thread

D
M8, 12 deep
M10, 15 deep
M16, 25 deep

Dimensions

NG	L1	L2	L3	L4	*L5	H1	H2	H3	H4	H5	H6	H7	H8	H9	B1	B2	B3
12	45	22.5	48	37	*10	130	84	46	24	106	281	78.5	53.5	292.3	122	28	238
18	55	27.5	60.5	27.5	*9	180	117	63	8	172	281	50.5	58.5	388.3	165	25	278
25	-	-	-	-	-	-	-	-	-	-	-	-	-	-	-	-	-

\* only for valves with more than 5 modules

**7.20 Actuator modules with type of actuation K0(K7)** (Fig. NG 12, K00(K70))

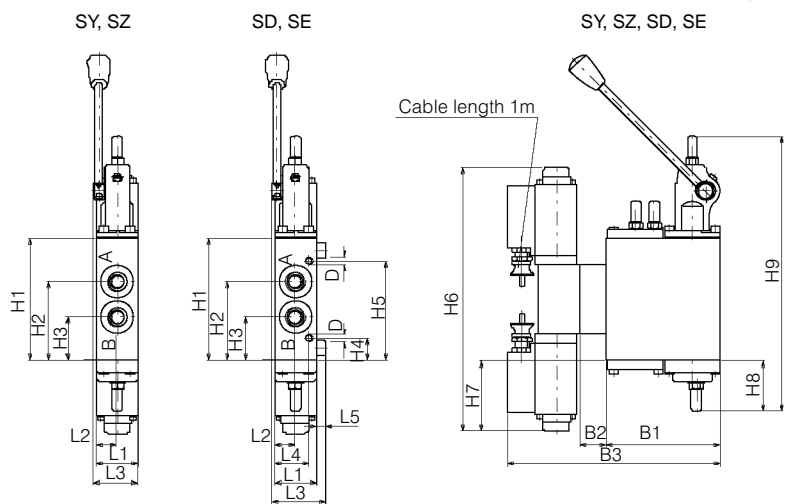

Connecting thread

NG	A/B
12	G 1/2
18	G1
25	G1 1/2

Fastening thread

D
M8, 12 deep
M10, 15 deep
M16, 25 deep

Dimensions

NG	L1	L2	L3	L4	*L5	H1	H2	H3	H4	H5	H6	H7	H8	H9	B1	B2	B3
12	45	22.5	48	37	*10	130	84	46	24	106	281	75.5	53.5	292.3	122	28	277
18	55	27.5	60.5	27.5	*9	180	117	63	8	172	281	50.5	58.5	388.3	165	25	267
25	-	-	-	-	-	-	-	-	-	-	-	-	-	-	-	-	-

\* only for valves with more than 5 modules

**BUCHER HYDRAULICS**

**Germany**

Phone +49 7742 85 20  
Fax +49 7742 71 16  
info.de@bucherhydraulics.com

**France**

Phone +33 389 64 22 44  
Fax +33 389 65 28 78  
info.fr@bucherhydraulics.com

**Netherlands**

Phone +31 79 34 26 24 4  
Fax +31 79 34 26 28 8  
info.nl@bucherhydraulics.com

**UK**

Phone +44 24 76 35 35 61  
Fax +44 24 76 35 35 72  
info.uk@bucherhydraulics.com

[www.bucherhydraulics.com](http://www.bucherhydraulics.com)

**USA**

Phone +1 262 605 82 80  
Fax +1 262 605 82 78  
info.wi@bucherhydraulics.com

**Switzerland**

Phone +41 33 67 26 11 1  
Fax +41 33 67 26 10 3  
info.ch@bucherhydraulics.com

**Italy**

Phone +39 0522 92 84 11  
Fax +39 0522 51 32 11  
info.it@bucherhydraulics.com

**Austria**

Phone +43 6216 44 97  
Fax +43 6216 44 97 4  
info.at@bucherhydraulics.com

**China**

Phone +86 10 64 44 32 38  
Fax +86 10 64 44 32 35  
info.bj@bucherhydraulics.com

**Product Center (Elevator)**

Phone +41 41 757 03 33  
Fax +41 41 757 16 49  
info.nh@bucherhydraulics.com

We reserve the right of modification without notice.