



OIL SOLUTIONS

**PO Box 38**  
**Strathfieldsaye, VIC, 3551**  
**1800 OIL SOL**  
**1800 645 765**

**[sales@oilsolutions.com.au](mailto:sales@oilsolutions.com.au)**

**[www.oilsolutions.com.au](http://www.oilsolutions.com.au)**

"For All Your Hydraulic Needs"

## Circulation pumps

## BFP

# Installation and Operation Instructions

Original instructions





Bühler Technologies GmbH, Harkortstr. 29, D-40880 Ratingen  
Tel. +49 (0) 21 02 / 49 89-0, Fax: +49 (0) 21 02 / 49 89-20  
Internet: [www.buehler-technologies.com](http://www.buehler-technologies.com)  
E-Mail: [fluidcontrol@buehler-technologies.com](mailto:fluidcontrol@buehler-technologies.com)

Read this instruction carefully prior to installation and/or use. Pay attention particularly to all advises and safety instructions to prevent injuries. Bühler Technologies can not be held responsible for misusing the product or unreliable function due to unauthorised modifications.

All rights reserved. Bühler Technologies GmbH 2022

Document information

Document No..... BE370001  
Version.....04/2022



1800-OILSOL  
1800-645765

<https://oilsolutions.com.au/>

[sales@oilsolutions.com.au](mailto:sales@oilsolutions.com.au)

# Contents

1	Introduction.....	2
1.1	Intended use .....	2
1.2	Scope of delivery.....	2
2	Safety instructions.....	3
2.1	Important advice.....	3
2.2	General hazard warnings .....	4
3	Transport and storage .....	5
4	Installation and connection .....	6
4.1	Requirements to the installation site.....	6
4.2	Installing the unit.....	6
4.2.1	Additional advices for units with pump.....	6
4.2.2	Installing swivel nuts in the fitting body .....	6
4.3	Hydraulic connection .....	7
4.4	Electrical connections .....	7
5	Operation and control .....	8
5.1	Before starting .....	8
5.2	During starting .....	8
6	Maintenance.....	9
7	Service and repair.....	11
7.1	Troubleshooting .....	11
8	Disposal .....	12
9	Appendices.....	13
9.1	Technical data .....	13
9.1.1	BFP 5/BFP 8/BFP 15.....	14
9.1.2	BFP 30/BFP 40 .....	15
9.1.3	BFP 60.....	16
9.1.4	BFP 90.....	17
9.2	Installation torques and clamping range for cable fitting .....	18
9.3	Screw torques .....	18
9.4	Hose torques .....	18
9.5	Calculations .....	18
9.5.1	Calculating viscosity .....	18
9.5.2	Table of operational viscosity for VG oil .....	19
9.5.3	Calculating the pressure loss .....	19
9.6	Pressure loss in straight pipes.....	19
10	Attached documents .....	21



# 1 Introduction

## 1.1 Intended use

BFP circulation pumps are suited for the transportation of oils in hydraulic and lubrication systems. Their scope is given by their specifications. The use in other applications is not permitted without confirmation by Bühler Technologies GmbH.

## 1.2 Scope of delivery

- 1 x Circulation pump
- Product documentation



1800-OILSOL  
1800-645765

<https://oilsolutions.com.au/>

[sales@oilsolutions.com.au](mailto:sales@oilsolutions.com.au)

## 2 Safety instructions

### 2.1 Important advice

Operation of the device is only permitted if:

- the product is used under the conditions described in the installation- and operation instruction, the intended application according to the type plate and the intended use. In case of unauthorized modifications done by the user Bühler Technologies GmbH can not be held responsible for any damage,
- when complying with the specifications and markings on the nameplates.
- the performance limits given in the datasheets and in the installation- and operation instruction are obeyed,
- monitoring devices and safety devices are installed properly,
- service and repair is carried out by Bühler Technologies GmbH,
- only original spare parts are used.

This manual is part of the equipment. The manufacturer keeps the right to modify specifications without advanced notice. Keep this manual for later use.

### Signal words for warnings

<b>DANGER</b>	Signal word for an imminent danger with high risk, resulting in severe injuries or death if not avoided.
<b>WARNING</b>	Signal word for a hazardous situation with medium risk, possibly resulting in severe injuries or death if not avoided.
<b>CAUTION</b>	Signal word for a hazardous situation with low risk, resulting in damaged to the device or the property or minor or medium injuries if not avoided.
<b>NOTICE</b>	Signal word for important information to the product.

### Warning signs

In this manual, the following warning signs are used:

	Warning against hazardous situations		Warning against high pressure
	Warning against electrical voltage		General notice
	Warning against hot surface		Disconnect from mains
	Warning against environmental hazard		Wear protection gloves
	Warning against potentially explosive atmospheres		



1800-OILSOL  
1800-645765

<https://oilsolutions.com.au/>

[sales@oilsolutions.com.au](mailto:sales@oilsolutions.com.au)

## 2.2 General hazard warnings

The equipment must be installed by a professional familiar with the safety requirements and risks.

Be sure to observe the safety regulations and generally applicable rules of technology relevant for the installation site. Prevent malfunctions and avoid personal injuries and property damage.

### The operator of the system must ensure:

- Safety notices and operating instructions are available and observed,
- The respective national accident prevention regulations are observed,
- The permissible data and operational conditions are maintained,
- Safety guards are used and mandatory maintenance is performed,
- Legal regulations are observed during disposal,
- compliance with national installation regulations.
- Nearby equipment is EMC protected, e.g. through shielding.
- The current and voltage supply for the aggregate has a (mains) separator with adequate switching capacity. National requirements must be observed.

### Maintenance, Repair

Please note during maintenance and repairs:

- Repairs to the unit must be performed by Bühler authorised personnel.
- Only perform conversion-, maintenance or installation work described in these operating and installation instructions.
- Always use genuine spare parts.
- Do not install damaged or defective spare part. If necessary, visually inspect prior to installation to determine any obvious damage to the spare parts.

Always observe the applicable safety and operating regulations in the respective country of use when performing any type of maintenance.

#### DANGER

#### Electrical voltage

Electrocution hazard.



- a) Disconnect the device from power supply.
- b) Make sure that the equipment cannot be reconnected to mains unintentionally.
- c) The device must be opened by trained staff only.
- d) Regard correct mains voltage.



#### CAUTION

#### Hot surface

Burning hazard

Let the device cool down before maintaining.



#### CAUTION

#### High pressure

Hazard of injury due to flung off parts or oil, environmental hazard due to oil.



- a) Before starting any maintenance or repair to the oil circuit, make sure that the device is depressurized. This applies to the threaded plugs as well.
- b) Avoid environmental pollution (oil spills) during cleaning or maintenance of the oil circuit.
- c) Use drip pans.

#### DANGER

#### Potentially explosive atmosphere

Explosion hazard if used in hazardous areas.

The device is not suitable for operation in hazardous areas with potentially explosive atmospheres.



### 3 Transport and storage

The products should be transported only in its original packaging or a suitable replacement. Secure device for transportation. When not in use, protect the equipment against moisture and heat. Keep it in a covered, dry and dust-free room at ambient temperature.



1800-OILSOL  
1800-645765

<https://oilsolutions.com.au/>

[sales@oilsolutions.com.au](mailto:sales@oilsolutions.com.au)

## 4 Installation and connection

### 4.1 Requirements to the installation site

#### Aggregate

The aggregate must be set up to allow for unobstructed air flow and adequate room for maintenance/repairs. When installed outdoors, be sure to consider the motor protection rating (standard: IP 55) and ensure adequate protection from the weather.

### 4.2 Installing the unit

The units are screwed in place at the attachment points using screws. Be sure the support structure is sized adequately. To protect the system from damage, the connections must be stress free. We recommend using flexible hoses. Be sure the hose is stable against negative pressure, e.g. steel wire reinforced. Avoid possible leaks in the circuit to prevent environmental damages. If necessary, use an oil pan. Protect the aggregate from mechanical impact.

#### 4.2.1 Additional advices for units with pump

The distance from the pump to the reservoir should be as short as possible. Especially the suction pipe should be short and of sufficient inner diameter.

We suggest mounting the pump in the same height as the liquid level. Mounting below the liquid level is possible as well.

If the aggregate can only be installed above this level, the pump will have a constant suction pressure of 0.4 bar (atmosphere). Depending on the oil viscosity and temperature, this will result in a different suction lift. A difference in value of 2 m can be used as a guide.

Until the oil is heated to operating temperature, a suction pressure of 0.6 bar is permissible temporarily.

The diameter of the intake pipe should not be smaller than specified in the data sheet. We recommend a max. flow speed of 1.5 m/s.

When first starting up a hydraulic system with a long intake pipe can cause problems due to excess air in the intake pipe. In this case we suggest filling the suction pipe with oil and using a suction valve without spring.

Oil is sprayed into the pump housing during the assembly process at our factory. This is necessary to seal the gerator from the housing with an oil film. During extended periods of storage the pump housing may not have enough oil anymore to create this oil film when switching on the pump. The pump may then completely lose suction. Before connecting the suction pipe we recommend spraying some oil into the pump housing to prevent this.

The pump may be exposed to max. 0.5 bar of pressure on the suction side.

#### 4.2.2 Installing swivel nuts in the fitting body

Proceed as follows:

- Carefully slide the preinstalled pipe end into the 24° cone on the fitting body.
- Tighten the swivel nut until a considerable increase in force can be felt (fixed point).
- Use a suitable spanner to tighten the swivel nut a 1/12 turn more (30°) beyond the fixed point. A marker line on the swivel nut and the fitting body facilitates observing the correct tightening angle.

Tube A.D.	Thread	Torque (Nm) for straight screwed plug	Torque (Nm) sealing plug
6	G 1/8"	18	13
8	G 1/4"	35	30
10	G 1/4"	35	30
12	G 3/8"	70	60
15	G 1/2"	90	80
18	G 1/2"	90	80
22	G 3/4"	180	140
28	G 1"	310	200
35	G 1 1/4"	450	400
42	G 1 1/2"	540	450

## 4.3 Hydraulic connection

Carry out the hydraulic connection as described in the attached data. Connect the lines stress and vibration free, so typically using hoses.

Be sure to use suitable lines (with regard to pressure, fluid resistance, environmental influences, fire) when connecting to the hydraulic-, lubrication circuit. Tighten the hose lines with a suitable torque (see appendix).

Contaminated fluids impact the life of the fluid system, we therefore recommend a purity class of 23/19/13 per ISO 4406.

If your hydraulic system is equipped with control or shut-off valves, we recommend protecting the cooling system with a pressure relief valve.

## 4.4 Electrical connections

### DANGER

#### Electrical voltage

Electrocution hazard.



- Disconnect the device from power supply.
- Make sure that the equipment cannot be reconnected to mains unintentionally.
- The device must be opened by trained staff only.
- Regard correct mains voltage.



### CAUTION

#### Electrical voltage

##### Wrong mains voltage may damage the device.

Installation of the device shall be performed by trained staff only. Regard the voltage given on the type plate. Make sure that the cables have sufficient strain relief.



##### Fusing

Fusing has to be done due to local standards!

##### Polarity

Take care of the directional rotation of the motor. The rotation direction is indicated on the motor housing "M" and an arrow.

Abb. 1



Abb. 2



The direction of rotation can be changed by reversing any two phases.

Use the applicable local regulations to determine the safety values and the cross-sections of connection leads. The motor and, if equipped, starting devices must be connected to protective earth.

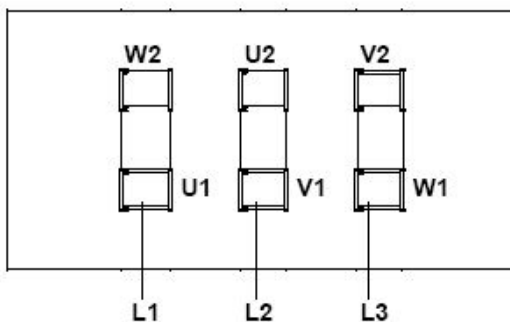
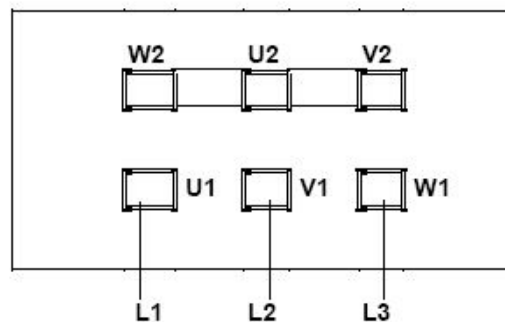
Lead fuses protect the cables in case of a short circuit, but are not sufficient to protect the motor coils from burning due to overload. Therefore, install an adequate motor circuit breaker with high precision range of adjustment for thermal protection to protect the motor against overload and operation with two phases

Adjust the motor circuit breaker according to the nominal value specified on the type plate of the motor. Operation outside the specified mains voltage and frequency range limits is prohibited.

Take appropriate measures to protect energised parts from being touched by persons and/or interference from foreign objects.

#### The operator of the equipment is responsible for ensuring lightning protection.

Connect the protective earth of the motor to the protective earth on site. Protective earth per DIN VDE 0100 must be connected to the marked earth lead terminal.

## 5 Operation and control

### NOTICE



The device must not be operated beyond its specifications.

### 5.1 Before starting

- Check that all parts are free of damage. Do not put a damaged device into operation.
- Check the correct connections of oil and power circuits according to chapter "Installation and connection".
- Make sure that all valves or other parts in the cooling circuit, which have to be opened, are opened.

### 5.2 During starting

First, check that the pump rotates counter clockwise. The direction is marked on the pump housing with M and directional arrow.

#### CAUTION



#### Hot surface

Burning hazard  
Let the device cool down before maintaining.

#### CAUTION



#### High pressure

Hazard of injury due to flung off parts or oil, environmental hazard due to oil.

- Before starting any maintenance or repair to the oil circuit, make sure that the device is depressurized. This applies to the threaded plugs as well.
- Avoid environmental pollution (oil spills) during cleaning or maintenance of the oil circuit.
- Use drip pans.

### Noise level

Our pump is supplied with a low noise. If the noise level increases significantly check if the suction line has the right dimension and if the pump works in the appropriate temp/viscosity range. Ask Bühler Technologies GmbH for technical advice.



1800-OILSOL  
1800-645765

<https://oilsolutions.com.au/>

[sales@oilsolutions.com.au](mailto:sales@oilsolutions.com.au)

## 6 Maintenance

During maintenance, remember:

- The equipment must be maintained by a professional familiar with the safety requirements and risks.
- Only perform maintenance work described in these operating and installation instructions.
- When performing maintenance of any type, observe the respective safety and operation regulations.

### DANGER

#### Electrical voltage

Electrocution hazard.



- Disconnect the device from power supply.
- Make sure that the equipment cannot be reconnected to mains unintentionally.
- The device must be opened by trained staff only.
- Regard correct mains voltage.



### CAUTION

#### Hot surface

Burning hazard

Let the device cool down before maintaining.



### CAUTION

#### High pressure

Hazard of injury due to flung off parts or oil, environmental hazard due to oil.



- Before starting any maintenance or repair to the oil circuit, make sure that the device is depressurized. This applies to the threaded plugs as well.
- Avoid environmental pollution (oil spills) during cleaning or maintenance of the oil circuit.
- Use drip pans.

Under normal operating conditions the aggregates are maintenance free. Preventive maintenance must therefore be routinely carried out by the operating company.

When doing so, please pay attention to:

- Tight screw fittings,
- Tightness,
- Damage to the aggregate (replace damaged parts),
- Abnormal (unusual) noise and vibration,
- Check warning labels for legibility and damage.

Electrical connections must be checked annually by a licensed electrician.

The external parts the motors, particularly the cooling ribs and cooling ducts as clean as possible to prevent compromising heat release.

Please note the specified protection against dust and moisture. Pressure cleaning is only permitted if the motor has the respective protection rating.

The motors feature ball bearings sealed on both sides. The grease filling is designed to last for the life of the unit. Greasing is not necessary.

The motor mounts may only be replaced by Bühler Technologies GmbH or a qualified specialist company.



1800-OILSOL  
1800-645765

<https://oilsolutions.com.au/>

[sales@oilsolutions.com.au](mailto:sales@oilsolutions.com.au)

## Condensate drain holes at motors from manufacturer WEG

If the motor is used in surrounding with high humidity this could lead, depending on the ambient temperature, to formation of condensate inside the motor housing. Specially at longer nonoperation period. The motors of WEG have a condensate drain plug which can be used for draining off. Pull out the plug according to the pictures and push it then back. If the plug is not pushed back or completely removed, the motor losses the IP degree of protection.

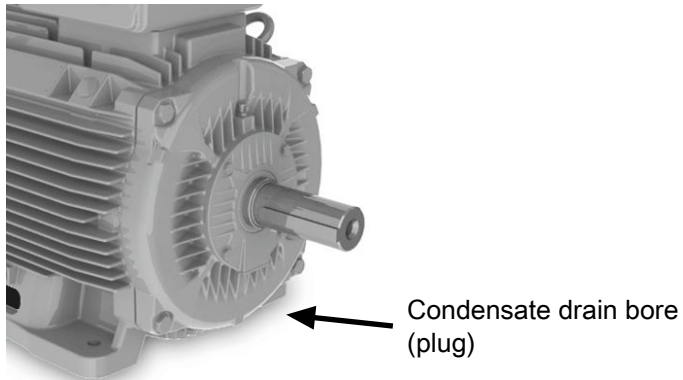

closed position

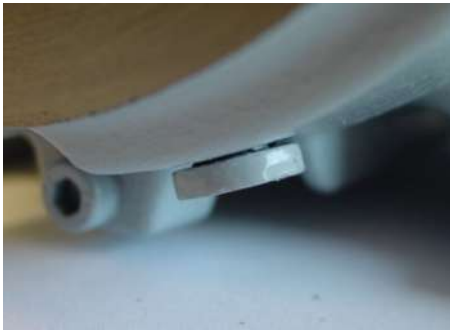

open position



plug



## 7 Service and repair

This chapter contains information on troubleshooting and correction should an error occur during operation.

Repairs to the unit must be performed by Bühler authorised personnel.

Please contact our Service Department with any questions:

**Tel.: +49-(0)2102-498955** or your agent

If the equipment is not functioning properly after correcting any malfunctions and switching on the power, it must be inspected by the manufacturer. Please send the equipment inside suitable packaging to:

**Bühler Technologies GmbH**

**- Reparatur/Service -**

**Harkortstraße 29**

**40880 Ratingen**

**Germany**

Please also attach the completed and signed RMA decontamination statement to the packaging. We will otherwise be unable to process your repair order.

You will find the form in the appendix of these instructions, or simply request it by e-mail:

**service@buehler-technologies.com.**

### 7.1 Troubleshooting

Problem / Failure	Possible cause	Solution
Oil flow not sufficient	– Motor's rotation direction wrong	– Correct connection, see Electrical connections
	– Motor doesn't start	– Correct connection, see Electrical connections
	– Oil flow too low	– Correct connection, see Electrical connections
	– Oil circuit blocked	– Open valves and cocks
	– Suction pressure too high, therefore reduced oil flow.	– Reduce suction height
	– Back pressure in the pressure line too big. Motor will be overloaded and motor speed braked down.	– Choose bigger nominal width of pressure line
No oil flow	– Not enough oil inside pump housing due to long standstill or storage, therefore no suction.	– Refill some oil into the pump housing before connecting the suction hose
Pump too noisy	– Suction pressure too high	– Select suction hose with sufficient diameter
		– Reduce suction height

Tab. 1: Troubleshooting



1800-OILSOL  
1800-645765

<https://oilsolutions.com.au/>

sales@oilsolutions.com.au

## 8 Disposal

Dispose of the parts in such a way that does not present a danger to other people's health or to the environment. Observe the legal requirements in the country of use for the disposal of electrical components and oils and coolants.



1800-OILSOL  
1800-645765

<https://oilsolutions.com.au/>

[sales@oilsolutions.com.au](mailto:sales@oilsolutions.com.au)

## 9 Appendices

### 9.1 Technical data

#### Technical Data

<b>Pump housing:</b>	Anodised and impregnated cast aluminium
<b>Gerotor:</b>	Sintered steel
<b>Colour:</b>	Motor RAL 7024
<b>Operating fluids:</b>	Mineral oils per DIN 51524
<b>Operating oil temperature:</b>	max. 80 °C (higher temperatures on request)
<b>Seal:</b>	Perbunan (NBR) or Viton (FPM) on request
<b>Ambient temperature:</b>	-15 °C to +40 °C

#### Electric motors

<b>Voltage / Frequency</b>	
<b>BFP 5-40:</b>	220/380V – 230/400V – 240/415V 50Hz 460V 60Hz
<b>BFP 60-90:</b>	220/380 – 245/420V 50Hz 220/380 – 280/480V 60Hz
<b>Thermal stability:</b>	Class of insulation F, utilisation per Class B
<b>Design:</b>	three-phase asynchronous squirrel-cage induction motor totally enclosed, fan cooled
<b>Protection class:</b>	IP55
<b>on request:</b>	other voltages higher motor power for higher viscosities UL- or CSA-approved motors higher protection class

The motors comply with standards  
IEC 60034, IEC 60072, IEC 60085

**Please also observe the operating manual for the motor! All pumps are supplied with cable gland inside the motor terminal box. The total length and height of the pump may vary by motor make.**

#### Pump selection information:

When selecting the pump model, choose the motor output according to the oil viscosity to be used. Motor output information refers to the maximum oil viscosity at maximum operating pressure.

The BFP 5 to BFP 40 are also available as a special version with a 6 bar internal bypass valve for protection. This does not change the dimensions.

#### Installation information:

The pump head of all pumps can be mounted turned in 90° increments to align with the line routing. Please note the offset from the centre of the motor.

The connection threads are manufactured to ISO 228. The screw-in surfaces are finished and suitable for the use of soft seals. We recommend using screwed plugs per ISO 1179-2.

#### Please note:

Especially note the dimension of the suction pipe. The cross-sections should not be smaller than specified. In most cases, loud noise indicates the cross-section was reduced too much.

Please refer to the notices in the operating instructions.



1800-OILSOL  
1800-645765

<https://oilsolutions.com.au/>

[sales@oilsolutions.com.au](mailto:sales@oilsolutions.com.au)

## 9.1.1 BFP 5/BFP 8/BFP 15

	BFP 5-6-0.55kW	BFP 8-4-0.75kW	BFP15-4-0.75kW	BFP15-4-1.1kW	BFP15-4-1.5kW
Item number	3705055**	3708075IE3**	3715075IE3**	3715110IE3**	3715150IE3**
Motor power	0.55 kW	0.75 kW	0.75 kW	1.1 kW	1.5 kW
max. oil viscosity	1500 cSt	1500 cSt	300 cSt	1500 cSt	2000 cSt
at max. operating pressure	10 bar	10 bar	10 bar	10 bar	10 bar
Number of poles	6	4	4	4	4
max. power input (400 V/50 Hz)*	approx. 1.5 A	approx. 1.6 A	approx. 1.6 A	approx. 2.4 A	approx. 3.2 A
Nominal delivery volume*	5.8 cm <sup>3</sup> /U	5.8 cm <sup>3</sup> /U	11.7 cm <sup>3</sup> /U	11.7 cm <sup>3</sup> /U	11.7 cm <sup>3</sup> /U
	5.5 L/min	8 L/min	16 L/min	16 L/min	16 L/min
Suction side connection	G1/2-DN16	G3/4/DN20	G1 1/4-DN32	G1 1/4-DN32	G1 1/4-DN32
Pressure side connection	G3/8-DN12	G1/2-DN16	G1-DN25	G1-DN25	G1-DN25
Suction pressure	-0.4 bar	-0.4 bar	-0.4 bar	-0.4 bar	-0.4 bar
for all models temporarily up to			-0.6 bar		
Acoustic power per ISO 3744*	52 dB(A)	56 dB(A)	59 dB(A)	59 dB(A)	59 dB(A)
Weight	18.5 kg	18.5 kg	18.1 kg	23.1 kg	27.1 kg
Dimensions					
A	96.5	96.5	96.5	102.5	102.5
B	314	314	313	331	356
C	86	86	86	98	98
D	100	100	100	100	125
E	77	77	77	87	87
F	80	80	80	90	90
G	125	125	125	140	140
H	149	149	149	164	164
I	220	220	220	249	249
J	82	82	70	70	70
K	71	71	60	60	60

\* For 60 Hz versions please multiply the delivery volume by a factor of 1.2. The acoustic emission increases by approx. 3 dB.

\*\*Electr. motor per NEMA, UL, CSA, EAC approval

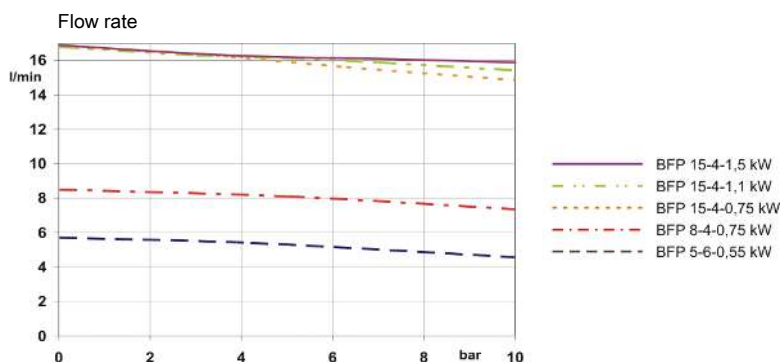
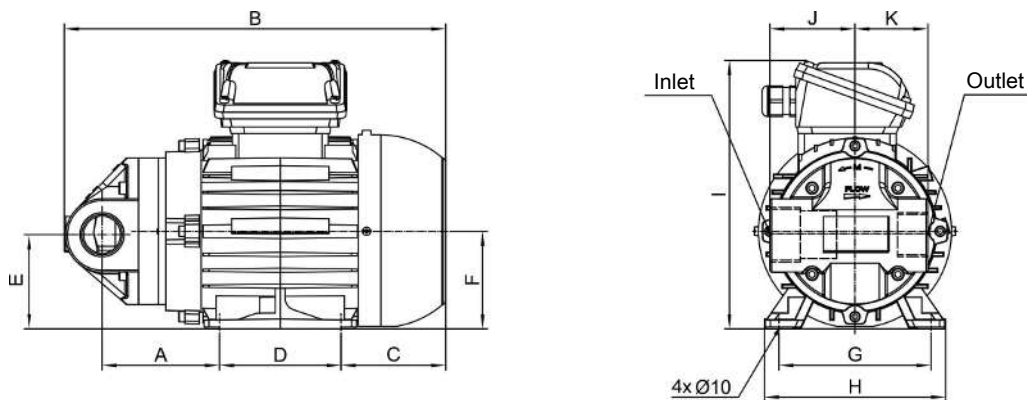

## 9.1.2 BFP 30/BFP 40

	BFP 30-4-0.75kW	BFP 30-4-1.1kW	BFP30-4-1.5kW	BFP40-4-1.1kW	BFP40-4-1.5kW
Item number	3730075IE3**	3730110IE3**	3730150IE3**	3740110IE3**	3740150IE3**
Motor power	0.75 kW	1.1 kW	1.5 kW	1.1 kW	1.5 kW
max. oil viscosity	100 cSt	300 cSt	1000 cSt	100 cSt	700 cSt
at max. operating pressure	6 bar	8 bar	10 bar	6 bar	8 bar
Number of poles	4	4	4	4	4
max. power input (400 V/50 Hz)*	approx. 1.6 A	approx. 2.4 A	approx. 3.2 A	approx. 2.4 A	approx. 3.2 A
Nominal delivery volume*	20.4 cm <sup>3</sup> /U 29 L/min	20.4 cm <sup>3</sup> /U 29 L/min	20.4 cm <sup>3</sup> /U 29 L/min	30.6 cm <sup>3</sup> /U 42 L/min	30.6 cm <sup>3</sup> /U 42 L/min
Suction side connection	G1 1/4-DN32	G1 1/4-DN32	G1 1/4-DN32	G1 1/4-DN32	G1 1/4-DN32
Pressure side connection	G1-DN25	G1-DN25	G1-DN25	G1-DN25	G1-DN25
Suction pressure for all models temporarily up to	-0.4 bar	-0.4 bar	-0.4 bar -0.6 bar	-0.4 bar	-0.4 bar
Acoustic power per ISO 3744*	61 dB(A)	61 dB(A)	61 dB(A)	62 dB(A)	62 dB(A)
Weight	18.8 kg	23.8 kg	28 kg	24.3 kg	28.3 kg
Dimensions					
A	95	101	101	110.5	110.5
B	312	330	355	340	364
C	86	98	98	98	98
D	100	100	125	100	125
E	77	87	87	87	87
F	80	90	90	90	90
G	125	140	140	140	140
H	149	164	164	164	164
I	220	249	249	249	249

\* For 60 Hz versions please multiply the delivery volume by a factor of 1.2. The acoustic emission increases by approx. 3 dB.

\*\*Electr. motor per NEMA, UL, CSA, EAC approval

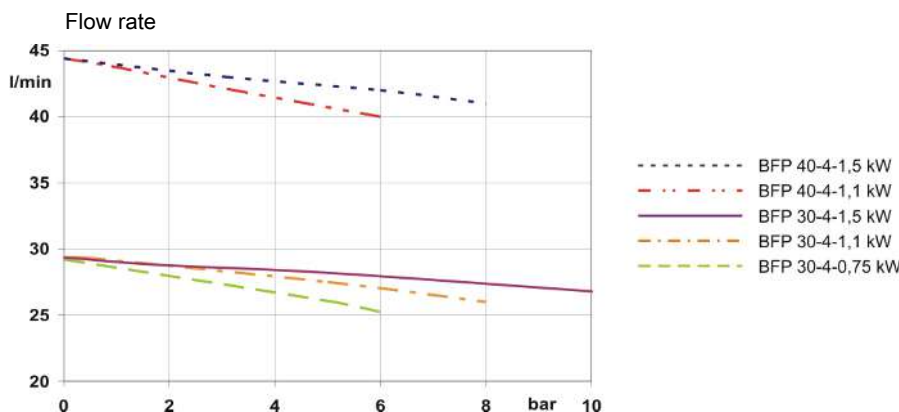
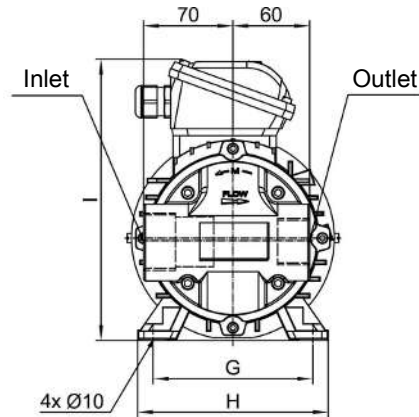
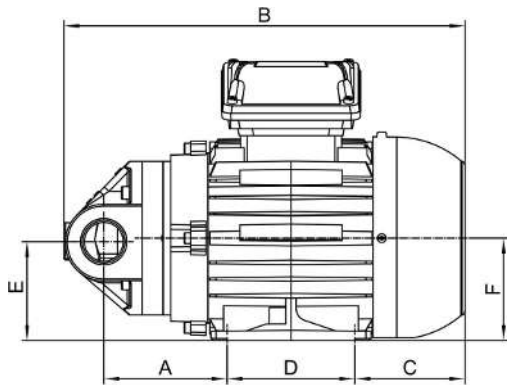

## 9.1.3 BFP 60

	BFP 60-4-1.5 kW	BFP 60-4-2.2kW	BFP 60-4-3kW	BFP 60-4-4kW
Item number	3760150IE3	3760220IE3	3760300IE3	3760400IE3
Motor power	1.5 kW	2.2 kW	3 kW	4 kW
max. oil viscosity	100 cSt	300 cSt	800 cSt	1500 cSt
at max. operating pressure	6 bar	8 bar	10 bar	8 bar
Number of poles	4	4	4	4
max. power input (400 V/50 Hz)*	approx. 3.5 A	approx. 4.6 A	approx. 6.4 A	approx. 8.0 A
Nominal delivery volume*	40.8 cm <sup>3</sup> /U	40.8 cm <sup>3</sup> /U	40.8 cm <sup>3</sup> /U	40.8 cm <sup>3</sup> /U
	58 L/min	58 L/min	58 L/min	58 L/min
Suction side connection	G1 1/2-DN40	G1 1/2-DN40	G1 1/2-DN40	G1 1/2-DN40
Pressure side connection	G1 1/4-DN32	G1 1/4-DN32	G1 1/4-DN32	G1 1/4-DN32
Suction pressure	-0.4 bar	-0.4 bar	-0.4 bar	-0.4 bar
for all models temporarily up to			-0.6 bar	
Acoustic power per ISO 3744*	64 dB(A)	64 dB(A)	64 dB(A)	64 dB(A)
Weight	20.9 kg	27.3 kg	31.5 kg	34.4 kg
Dimensions				
A	150	172	172	179
B	412	455	455	477
C	106	112	112	127
D	125	140	140	140
E	87	97	97	109
F	90	100	100	112
G	140	160	160	190
H	175	200	200	226
I	230	255	255	278.5
J	10	12	12	12

\* For 60 Hz versions please multiply the delivery volume by a factor of 1.2. The acoustic emission increases by approx. 3 dB.

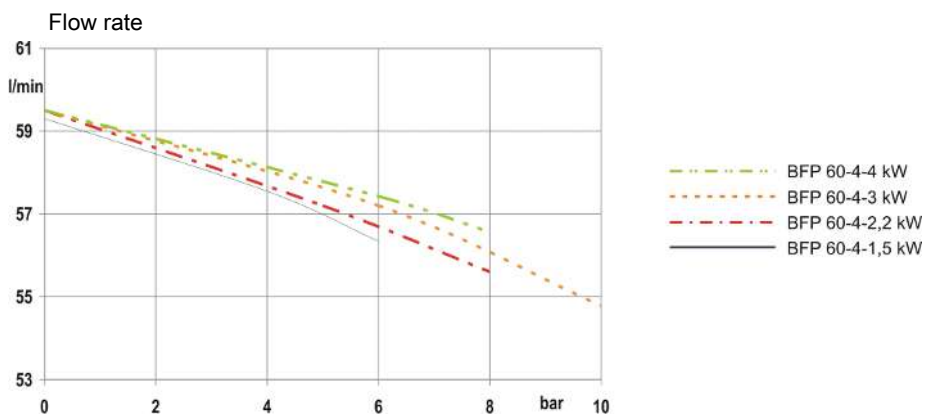
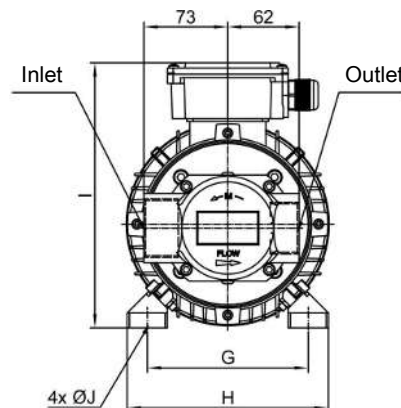
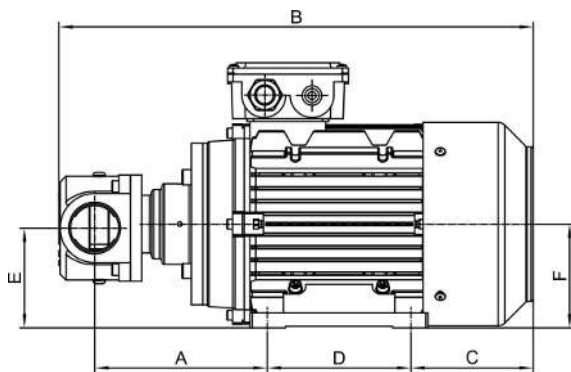

## 9.1.4 BFP 90

	BFP 90-4-1.5kW	BFP 90-4-2.2 kW	BFP 90-4-3kW	BFP 90-4-4kW
Item number	3790150IE3	3790220IE3	3790300IE3	3790400IE3
Motor power	1.5 kW	2.2 kW	3 kW	4 kW
max. oil viscosity	46 cSt	100 cSt	300 cSt	1000 cSt
at max. operating pressure	6 bar	8 bar	8 bar	8 bar
Number of poles	4	4	4	4
max. power input (400 V/50 Hz)*	approx. 3.5 A	approx. 4.6 A	approx. 6.4 A	approx. 8.0 A
Nominal delivery volume*	61.2 cm <sup>3</sup> /U	61.2 cm <sup>3</sup> /U	61.2 cm <sup>3</sup> /U	61.2 cm <sup>3</sup> /U
	88 L/min	88 L/min	88 L/min	88 L/min
Suction side connection	G1 1/2-DN40	G1 1/2-DN40	G1 1/2-DN40	G1 1/2-DN40
Pressure side connection	G1 1/4-DN32	G1 1/4-DN32	G1 1/4-DN32	G1 1/4-DN32
Suction pressure	-0.4 bar	-0.4 bar	-0.4 bar	-0.4 bar
for all models temporarily up to			-0.6 bar	
Acoustic power per ISO 3744*	65 dB(A)	65 dB(A)	65 dB(A)	65 dB(A)
Weight	21.9 kg	24.8 kg	24.8 kg	34.2 kg
Dimensions				
A	162.5	184.5	184.5	191.5
B	445	483	500	511
C	104	105	122	126
D	125	140	140	140
E	87	97	97	109
F	90	100	100	112
G	140	160	160	190
H	175	198	198	222
J	226	248	248	276
K	10	12	12	12

\* For 60 Hz versions please multiply the delivery volume by a factor of 1.2. The acoustic emission increases by approx. 3 dB.

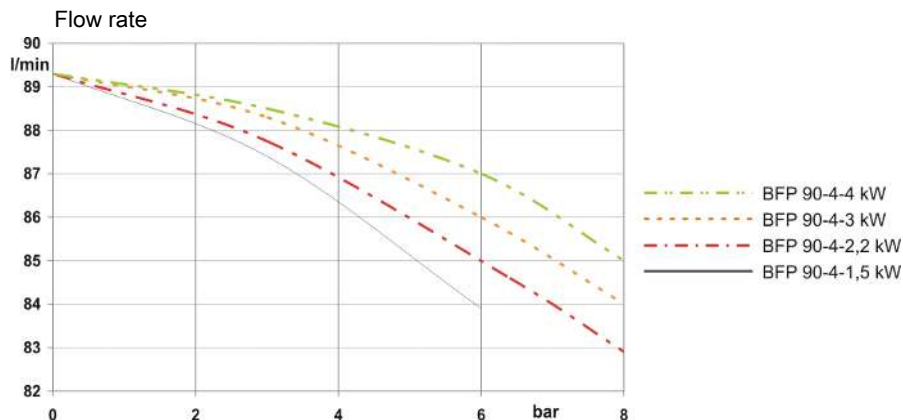
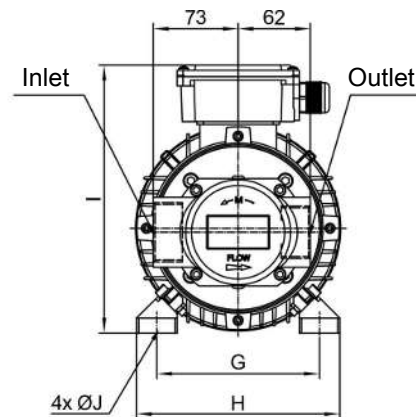
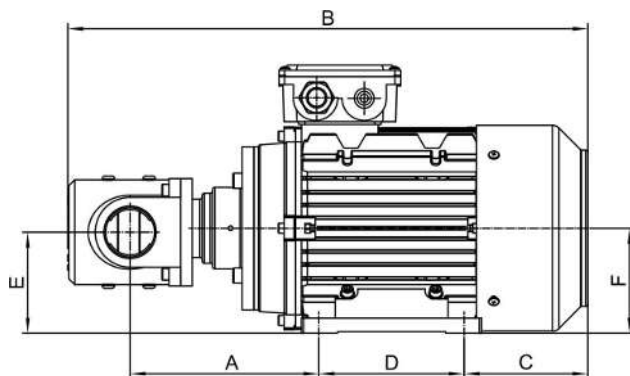

## 9.2 Installation torques and clamping range for cable fitting

Size	Strain relief clamping range (mm)	Installation torque (Nm)
M12x1,5	3-6	1,5
M16x1,5	5-9,5	2,5
M20x1,5	8-13	3,5
M25x1,5	11-17	5
M32x1,5	15-21	5
M40x1,5	19-28	7,5
M50x1,5	27-35	7,5
M63x1,5	32-42	13

## 9.3 Screw torques

Thread	Torque (Nm)
M5	4
M6	8
M8	15
M10	30
M12	51

## 9.4 Hose torques

Connections/mounts	Torque (Nm)
Hose connections DN20	180
Hose connections DN25	250
Hose connections DN32	350

## 9.5 Calculations

### 9.5.1 Calculating viscosity

Valid for VG-oil between 10 - 100 °C at an exactness from ± 5 %.

Definitions  
 $V_{40}$  oil viscosity at 40 °C in cst  
 $T$  temperature in °C  
 $\nu$  viscosity in cst

$$b = 159 \cdot \ln \frac{V_{40}}{0,23}$$

$$a = 0,23 \cdot e^{\frac{-b}{877}}$$

$$\nu = a \cdot e^{\frac{b}{T+95,2}}$$

Example: oil VG 46

$V_{40}$  46 cst  
 $T$  25 °C

$$b = 159 \cdot \ln \frac{46}{0,23} = 842,4325$$

$$a = 0,23 \cdot e^{\frac{-842,4325}{877}} = 0,08801$$

$$\nu = 0,08801 \cdot e^{\frac{842,4325}{25+95,2}} = 97,35 \text{ cst}$$



1800-OILSOL  
1800-645765

<https://oilsolutions.com.au/>

[sales@oilsolutions.com.au](mailto:sales@oilsolutions.com.au)

## 9.5.2 Table of operational viscosity for VG oil

	10 °C	20 °C	30 °C	40 °C	50 °C	60 °C	70 °C	80 °C	90 °C
VG 46	264,45	131,96	73,58	46,00	29,13	20,04	14,43	10,78	8,32
VG 68	444,77	210,85	112,61	68,00	41,63	27,86	19,58	14,32	10,84
VG 220	2.120,17	861,60	404,31	220,00	121,71	74,99	49,00	33,61	24,01
VG 320	3.489,92	1.350,22	607,96	320,00	171,40	102,85	65,66	44,12	30,94

Viscosity given in cst (mm<sup>2</sup>/s)

## 9.5.3 Calculating the pressure loss

Valid for smooth straight piping per meter at laminar current.

	<b>Definitions</b>		<b>Example: oil VG 46</b>
$\nu$	Viscosity in cst	$\nu$	97,35 cst
$\rho$	spec. gravity in kg/dm <sup>3</sup>	$\rho$	0,8817 kg/dm <sup>3</sup>
DN	tube diameter in mm	DN	20 mm
V	flow in m/s	V	3,18 m/s (60 l/min for tube DN 20)
PV	pressure loss in bar		
	$PV = \frac{0,32 \cdot \nu \cdot \rho \cdot V}{DN^2}$		$PV = \frac{0,32 \cdot 97,35 \cdot 0,8817 \cdot 3,18}{20^2} = 0,22 \text{ bar}$

### NOTICE



Pressure loss increases significantly for bends and fittings. It might be necessary in some cases to determine the final shape of the suction line on site under specific conditions.

Please do not hesitate to contact us for help to calculate the pressure loss of the suction line for you specific application.

### NOTICE



To avoid damage of the cooling system, make sure that the maximum pump pressure is not exceeded. High pressure may occur if the system is shut off or throttled at the pressure side.

## 9.6 Pressure loss in straight pipes

### Pressure loss (bar) per metre in straight tubing with laminar flow of mineral oil:

#### BFP 8 8 l/min – DN 25

	VG 46	VG 68	VG 120	VG 160	VG 220	VG 320	VG 460	VG 680
10 °C	0.03	0.05	0.11	0.17	0.25	0.42	0.68	1.14
20 °C	0.02	0.03	0.05	0.07	0.10	0.16	0.25	0.40
30 °C	0.01	0.01	0.02	0.03	0.05	0.07	0.11	0.17
40 °C	0.01	0.01	0.01	0.03	0.03	0.04	0.05	0.08
50 °C	0.01	0.01	0.01	0.02	0.01	0.02	0.03	0.04
60 °C – 100 °C	< 0.03 bar							

#### BFP 15 16 l/min – DN 32

	VG 46	VG 68	VG 120	VG 160	VG 220	VG 320	VG 460	VG 680
10 °C	0.02	0.04	0.08	0.12	0.19	0.31	0.50	0.85
20 °C	0.01	0.02	0.04	0.10	0.08	0.12	0.19	0.30
30 °C	0.01	0.01	0.02	0.05	0.04	0.05	0.08	0.12
40 °C	0.01	0.01	0.01	0.01	0.02	0.03	0.04	0.06
50 °C	0.01	0.01	0.01	0.01	0.01	0.02	0.01	0.03
60 °C – 100 °C	< 0.02 bar							

**BFP 30 28 l/min – DN 32**

	VG 46	VG 68	VG 120	VG 160	VG 220	VG 320	VG 460	VG 680
<b>10 °C</b>	0.04	0.07	0.15	0.22	0.33	0.54	0.88	1.48
<b>20 °C</b>	0.02	0.03	0.06	0.09	0.13	0.21	0.33	0.52
<b>30 °C</b>	0.01	0.02	0.03	0.04	0.07	0.09	0.14	0.22
<b>40 °C</b>	0.01	0.01	0.02	0.02	0.03	0.05	0.07	0.10
<b>50 °C</b>	0.01	0.01	0.01	0.01	0.02	0.03	0.04	0.06

**60 °C – 100 °C** < 0.03 bar**BFP 60 57 l/min – DN 40**

	VG 46	VG 68	VG 120	VG 160	VG 220	VG 320	VG 460	VG 680
<b>10 °C</b>	0.03	0.06	0.12	0.18	0.28	0.45	0.74	1.24
<b>20 °C</b>	0.02	0.03	0.05	0.08	0.11	0.18	0.27	0.43
<b>30 °C</b>	0.01	0.01	0.03	0.04	0.05	0.08	0.12	0.18
<b>40 °C</b>	0.01	0.01	0.02	0.02	0.02	0.04	0.06	0.08
<b>50 °C</b>	0.01	0.01	0.01	0.01	0.02	0.02	0.03	0.05

**60 °C – 100 °C** < 0.03 bar**BFP 90 86 l/min – DN 40**

	LVG 46	VG 68	VG 120	VG 160	VG 220	VG 320	VG 460	VG 680
<b>10 °C</b>	0.05	0.09	0.19	0.27	0.42	0.68	1.11	1.87
<b>20 °C</b>	0.03	0.04	0.08	0.12	0.17	0.26	0.41	0.65
<b>30 °C</b>	0.02	0.02	0.04	0.06	0.08	0.12	0.18	0.27
<b>40 °C</b>	0.01	0.01	0.02	0.03	0.04	0.06	0.09	0.13
<b>50 °C</b>	0.01	0.01	0.01	0.02	0.02	0.03	0.05	0.07

**60 °C – 100 °C** < 0.04 bar**Note:** Values in blue exceed the suction operation limit of -0.4 bar.

1800-OILSOL  
1800-645765

<https://oilsolutions.com.au/>

[sales@oilsolutions.com.au](mailto:sales@oilsolutions.com.au)

## 10 Attached documents

- Declaration of conformity KX 370001
- RMA - Decontamination Statement



1800-OILSOL  
1800-645765

<https://oilsolutions.com.au/>

[sales@oilsolutions.com.au](mailto:sales@oilsolutions.com.au)

**EG-/EU Konformitätserklärung**  
**EC/EU Declaration of Conformity**



Hiermit erklärt Bühler Technologies GmbH,  
dass die nachfolgenden Produkte den  
wesentlichen Anforderungen der Richtlinie

**2006/42/EG**

**(MRL)**

in ihrer aktuellen Fassung entsprechen.

Die Produkte sind Maschinen nach Artikel 2 a).

Folgende Richtlinien wurden berücksichtigt:

*Herewith declares Bühler Technologies GmbH  
that the following products correspond to the  
essential requirements of Directive*

**2006/42/EC**

**(MD)**

*in its actual version.*

*The products are machines according to article 2 (a).*

*The following directives were regarded:*

**2014/30/EU (EMV/EMC)**

**2014/35/EU (NSR/LVD)**

**Produkt / products:** Förderpumpen / Circulation pump

**Typ / type:** BFP

Die Betriebsmittel dienen zur Förderung von Ölen in Hydraulik-und Schmierkreisläufen.

*The equipment is suited for transportation of oils in hydraulic and lubrication systems.*

Das oben beschriebene Produkt der Erklärung erfüllt die einschlägigen

Harmonisierungsrechtsvorschriften der Union:

*The object of the declaration described above is in conformity with the relevant Union harmonisation  
legislation:*

**EN ISO 12100:2010**

**EN 60204-1:2006**

**EN 61000-6-2:2005**

**EN 55011:2009**

Die alleinige Verantwortung für die Ausstellung dieser Konformitätserklärung trägt der Hersteller.

*This declaration of conformity is issued under the sole responsibility of the manufacturer.*

Dokumentationsverantwortlicher für diese Konformitätserklärung ist Herr Stefan Eschweiler mit  
Anschrift am Firmensitz.

*The person authorised to compile the technical file is Mr. Stefan Eschweiler located at the company's  
address.*

Ratingen, den 05.02.2019

Stefan Eschweiler  
Geschäftsführer – Managing Director

Frank Pospiech  
Geschäftsführer – Managing Director

KX 37 0001

Bühler Technologies GmbH, Harkortstr. 29, D-40880 Ratingen,  
Tel. +49 (0) 21 02 / 49 89-0, Fax. +49 (0) 21 02 / 49 89-20  
Internet: [www.buehler-technologies.com](http://www.buehler-technologies.com)



1800-OILSOL  
1800-645765

<https://oilsolutions.com.au/>

[sales@oilsolutions.com.au](mailto:sales@oilsolutions.com.au)

# RMA-Formular und Erklärung über Dekontaminierung

## RMA-Form and explanation for decontamination



RMA-Nr./ RMA-No.

Die RMA-Nummer bekommen Sie von Ihrem Ansprechpartner im Vertrieb oder Service./ You may obtain the RMA number from your sales or service representative.

Zu diesem Rücksendeschein gehört eine Dekontaminierungserklärung. Die gesetzlichen Vorschriften schreiben vor, dass Sie uns diese Dekontaminierungserklärung ausgefüllt und unterschrieben zurücksenden müssen. Bitte füllen Sie auch diese im Sinne der Gesundheit unserer Mitarbeiter vollständig aus./ This return form includes a decontamination statement. The law requires you to submit this completed and signed decontamination statement to us. Please complete the entire form, also in the interest of our employee health.

### Firma/ Company

Firma/ Company   
Straße/ Street   
PLZ, Ort/ Zip, City   
Land/ Country

Gerät/ Device   
Anzahl/ Quantity   
Auftragsnr./ Order No.

### Ansprechpartner/ Person in charge

Name/ Name   
Abt./ Dept.   
Tel./ Phone   
E-Mail   
Serien-Nr./ Serial No.   
Artikel-Nr./ Item No.

### Grund der Rücksendung/ Reason for return

- Kalibrierung/ Calibration       Modifikation/ Modification  
 Reklamation/ Claim             Reparatur/ Repair  
 andere/ other

bitte spezifizieren/ please specify

### Ist das Gerät möglicherweise kontaminiert?/ Could the equipment be contaminated?

- Nein, da das Gerät nicht mit gesundheitsgefährdenden Stoffen betrieben wurde./ No, because the device was not operated with hazardous substances.  
 Nein, da das Gerät ordnungsgemäß gereinigt und dekontaminiert wurde./ No, because the device has been properly cleaned and decontaminated.  
 Ja, kontaminiert mit:/ Yes, contaminated with:



explosiv/  
explosive



entzündlich/  
flammable



brandfördernd/  
oxidizing



komprimierte  
Gase/  
compressed  
gases



ätzend/  
caustic



giftig,  
Lebensgefahr/  
poisonous, risk  
of death



gesundheitsge-  
fährdend/  
harmful to  
health



gesund-  
heitsschädlich/  
health hazard



umweltge-  
fährdend/  
environmental  
hazard

### Bitte Sicherheitsdatenblatt beilegen!/ Please enclose safety data sheet!

Das Gerät wurde gespült mit:/ The equipment was purged with:

*Diese Erklärung wurde korrekt und vollständig ausgefüllt und von einer dazu befugten Person unterschrieben. Der Versand der (dekontaminierten) Geräte und Komponenten erfolgt gemäß den gesetzlichen Bestimmungen.*

*This declaration has been filled out correctly and completely, and signed by an authorized person. The dispatch of the (decontaminated) devices and components takes place according to the legal regulations.*

Falls die Ware nicht gereinigt, also kontaminiert bei uns eintrifft, muss die Firma Bühler sich vorbehalten, diese durch einen externen Dienstleister reinigen zu lassen und Ihnen dies in Rechnung zu stellen.

Should the goods not arrive clean, but contaminated, Bühler reserves the right, to commission an external service provider to clean the goods and invoice it to your account.

Firmenstempel/ Company Sign

Datum/ Date

Bühler Technologies GmbH, Harkortstr. 29, D-40880 Ratingen  
Tel. +49 (0) 21 02 / 49 89-0, Fax: +49 (0) 21 02 / 49 89-20  
E-Mail: [service@buehler-technologies.com](mailto:service@buehler-technologies.com)  
Internet: [www.buehler-technologies.com](http://www.buehler-technologies.com)

rechtsverbindliche Unterschrift/ Legally binding signature

DE000011 01/2019



1800-OILSOL  
1800-645765

<https://oilsolutions.com.au/>

[sales@oilsolutions.com.au](mailto:sales@oilsolutions.com.au)



*Die Analyse defekter Baugruppen ist ein wesentlicher Bestandteil der Qualitätssicherung der Firma Bühler Technologies.*

*Um eine aussagekräftige Analyse zu gewährleisten muss die Ware möglichst unverändert untersucht werden. Es dürfen keine Veränderungen oder weitere Beschädigungen auftreten, die Ursachen verdecken oder eine Analyse unmöglich machen.*

*Bei elektronischen Baugruppen kann es sich um elektrostatisch sensible Baugruppen handeln. Es ist darauf zu achten, diese Baugruppen ESD-gerecht zu behandeln. Nach Möglichkeit sollten die Baugruppen an einem ESD-gerechten Arbeitsplatz getauscht werden. Ist dies nicht möglich sollten ESD-gerechte Maßnahmen beim Austausch getroffen werden. Der Transport darf nur in ESD-gerechten Behältnissen durchgeführt werden. Die Verpackung der Baugruppen muss ESD-konform sein. Verwenden Sie nach Möglichkeit die Verpackung des Ersatzteils oder wählen Sie selber eine ESD-gerechte Verpackung.*

*Beachten Sie beim Einbau des Ersatzteils die gleichen Vorgaben wie oben beschrieben. Achten Sie auf die ordnungsgemäße Montage des Bauteils und aller Komponenten. Versetzen Sie vor der Inbetriebnahme die Verkabelung wieder in den ursprünglichen Zustand. Fragen Sie im Zweifel beim Hersteller nach weiteren Informationen.*

*Analysing defective assemblies is an essential part of quality assurance at Bühler Technologies.*

*To ensure conclusive analysis the goods must be inspected unaltered, if possible. Modifications or other damages which may hide the cause or render it impossible to analyse are prohibited.*

*Electronic assemblies may be sensitive to static electricity. Be sure to handle these assemblies in an ESD-safe manner. Where possible, the assemblies should be replaced in an ESD-safe location. If unable to do so, take ESD-safe precautions when replacing these. Must be transported in ESD-safe containers. The packaging of the assemblies must be ESD-safe. If possible, use the packaging of the spare part or use ESD-safe packaging.*

*Observe the above specifications when installing the spare part. Ensure the part and all components are properly installed. Return the cables to the original state before putting into service. When in doubt, contact the manufacturer for additional information.*



1800-OILSOL  
1800-645765

<https://oilsolutions.com.au/>

[sales@oilsolutions.com.au](mailto:sales@oilsolutions.com.au)

