

“D” Design Series

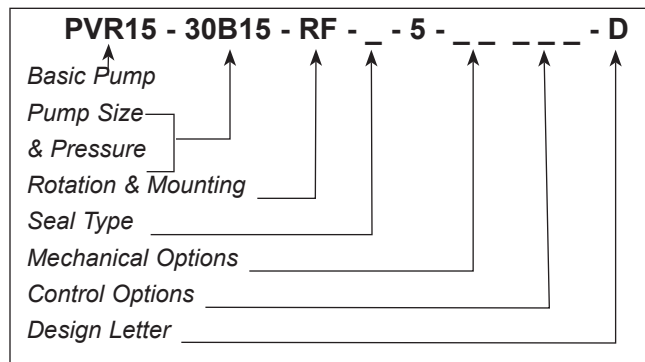

This service manual applies to products with Ordering Codes like the sample below.



CAUTION - Before performing any service operation on any pump, be sure that all pressure has been relieved from BOTH SIDES of the system.



CAUTION - Before performing any service operation on any pump, disconnect or lock off power supply.



CAUTION - Before starting pump, be sure that any resulting machine function will not endanger persons or equipment.

PRODUCT IDENTIFICATION

Each pump has an Ordering Code stamped on its nameplate. See below for the location of the Ordering Code.

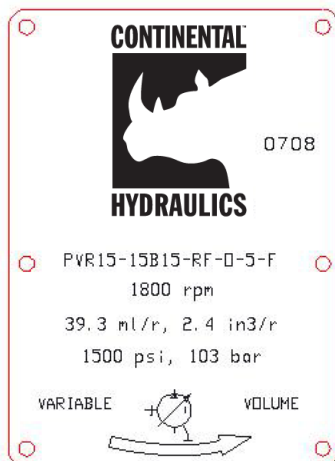

INSTALLATION

PUMP DRIVE AND MOUNTING

When mounting the pump and motor, care must be taken to align the pump and motor shafts within .003 T.I.R. (0.076 mm) direct inline through a jaw type/flexible web coupling. This is recommended for all pumps. Tire-type flexing elements and chain-type drives are not recommended. With belt drives, please consult factory.

To avoid axial and radical end loading of the pump shaft, do not couple the pump and motor shafts rigidly. Allow freedom at the coupling for the two shafts to ride independently.

To prevent end loading, the space between the pump and motor shaft ends should be 3/4 inch (19.05 mm) for PVR15 pumps, or as the coupling manufacturer specifies.

PIPING AND RESERVOIR

The pump should be mounted with a minimum number of elbows or fittings. The pump suction should be at least 1-1/4 inch (31.75 mm) tube/pipe for PVR15 pumps.

For any system and combination of piping except High Water Based Fluids (HWBF), the vacuum at the pump inlet must not exceed seven inches of Mercury, (5 inch Hg. for fire resistant fluids). HWBF Pumps are to have a positive inlet head in the range of 0.5-inch Hg. to 20 inch Hg.



OIL SOLUTIONS

PO Box 38
Strathfieldsaye, VIC, 3551
1800 OIL SOL
1800 645 765

sales@oilsolutions.com.au

www.oilsolutions.com.au

"For All Your Hydraulic Needs"

Installation (Continued...)

Piping should be done with pickled pipe or seamless tubing free of dirt and scale. Do not use galvanized or other pipe that tends to flake off.

A 100-mesh screen (60 mesh for fire resistant and HWBF) should be used on the pump suction line. The screen should be located approximately two inches (50.8 mm) from the bottom of the tank. All lines returning oil to the tank should discharge at least two inches (50.8 mm) below the minimum oil level and should be separated from the pump suction area by means of a baffle. These lines should also include a 10-micron return line filter, with the exception of the case drain line.

The pump case drain should be connected directly to the tank. Pressure in excess of 10 psi (0.7 bar) in the case drain line can result in shaft seal leakage. It is recommended that the case drain be returned to the tank by a separate 3/8-inch (9.5 mm) line.

STARTUP PROCEDURES

The following instructions apply for initial startup of the hydraulic pump. After an extended shutdown period, start with item 5.



CAUTION - Never start a new pump installation against a blocked system.

1. Check the nameplate for model number and rpm. The arrow on the pump casting indicates direction of rotation.
2. Pump suction line should extend below the lowest point of oil level but not less than two inches (50.8 mm) above reservoir bottom.
3. The pump and motor shafts must be aligned within .003 inches (0.076 mm). See Pump Drive and Mounting directions above for restrictions.
4. Connect the case drain directly to tank (or to a heat exchanger if the pump will be deadheading for long periods of time during operation), using a full-size line corresponding to the case drain in the pump or manifold. If connected to a heat exchanger, the case drain line should be protected with a 10 psi (0.7 bar) maximum relief valve in parallel with the heat exchanger. No other return lines should be connected in common with the case drain return.
5. Rotate pump and motor by hand to insure free rotation.
6. Set the machine controls to open the circuit and

allow free flow from the pump back to tank or connect the pump outlet line directly to tank. Jog the motor on and off several times (on two seconds, off three seconds) until the pump is primed. Check pump for proper direction of rotation during the jogging.

7. After the pump has been primed, run it for several minutes at lower than normal pressures with an open or intermittently open system which permits oil flow. This will purge entrapped air from the pump and system.
8. Neither volume adjustment nor pressure adjustment should be adjusted until the pump has been primed and running, and air is purged.
9. After air has been purged from the system, the system can be closed and the pump adjusted to the required operating pressure.
10. If necessary, the volume adjustment can be adjusted to limit maximum output.
11. When replacing pumps, the suction screen in the reservoir must be removed and thoroughly cleaned. Also, the suction line from the reservoir to the pump should be flushed inside and out to remove any contaminants. Pieces of metal from a damaged pump can back up into this line. If they are not removed, they will be drawn into the new pump and destroy it. Start unit by using proper pump start-up procedure items 1 through 10.



CAUTION - If both pressure and volume modifications are supplied on the pump, the pressure should be adjusted before the volume. Volume should be adjusted at minimum pump pressure or at deadhead. Stop adjustment at the volume screw when pressure begins to drop.

OPERATION

PRESSURE AND VOLUME ADJUSTMENTS

Pressure Control

All pumps are adjusted to reduced pressure before shipment and must be readjusted to the required system pressure after installation and start-up.

The pressure adjusting screw is located at the end face of the compensator chamber. See parts page item number 30. The adjusting screw has a right hand thread; clockwise adjustment increases pressure; counterclockwise reduces pressure.

Operation (Continued...)

A pressure gauge located at the pump must be used when making adjustment to insure the pressure settings do not exceed limits specified for the particular pump of maximum system pressure.

Make all pressure settings with pump operating against a closed circuit, that is with the output of the pump blocked, and then check pressure throughout the pump flow range.

Volume Control

Adjust volume at minimum pump pressure or at pump deadhead. The volume adjusting screw is directly opposite the pressure adjusting screw, see parts page item number 55. The adjusting screw has a right hand thread, turning the screw clockwise decreases the maximum volume, turning the screw counterclockwise increases the maximum volume. Pumps are set at a maximum rated volume at the factory unless otherwise specified.

Stop adjustment of the volume screw when pressure begins to drop. See Sales Catalog for complete pump performance specifications.

ADJUSTMENT PROCEDURES

To adjust the maximum output volume use the following steps:

1. Set the pump at minimum pressure.
2. Hand tighten the volume screw until it touches pressure ring. **NOTE:** The pump should be at full flow for this step.

3. See Pressure and Volume Adjustment Sensitivity chart below.

4. Deadhead the pump, turn the volume screw the proper number of turns to obtain the flow desired.

5. Return pump to flow condition and check flow rate. If output flow is incorrect, switch pump to deadhead and readjust.

CAUTION - Turning the maximum volume control in too far can force the pressure ring over-center and destroy the pump.

Pressure and Volume Adjustment Sensitivity

		PUMP SIZE	
		30B	
Pressure Adjustment	Pressure Change/Turn	psi (bar)	240 (16.5)
	Maximum Torque	ft.-lbs. (m-kg)	2.7 (0.37)
	Flow Change/Turn	gpm (lpm)	4.6 (17.4)
Volume Adjustment	Approx. Min. Flow Adjust.	gpm (lpm)	1.0 (3.7)
	Maximum Torque	ft.-lbs. (m-kg)	3.5 (0.48)

PVR15-30B KIT LIST (Refer to Drawing and Parts List)

WEAR PLATE KITS	
Includes Items: 4 & 5	
Model	Kit Number
30B	252933
SEAL KITS	
Includes Items: 13,14,15,16,17,24,25,85,86,99	
Model	Kit Number
All Buna-N	250008
All Viton	250009
VANE KITS	
Includes Items: 7	
Model	Kit Number
30B	252932

ROTATING KITS		
Includes Items: 3, 6 & 21		
Model	Code	Kit Number
30B		Consult Factory
30B	12	252935
30B	21	Consult Factory
30B	22	Consult Factory

COMPLETE REBUILD KITS		
Includes Items: All Kits Listed Here Plus Items 11 & 22		
Model	Code	Kit Number
30B		252899
30B	12	252938
30B	21	254999
30B	22	255002

PVR15-30B PARTS LIST

ITEM NO.	CODE	PART NO.	DESCRIPTION	QTY. REQ.	ITEM NO.	CODE	PART NO.	DESCRIPTION	QTY. REQ.
1		550360	Pump Body	1	43		122975	Shim (.010)	A.R.
2		550629	Cover	1	44	15	301737	Handwheel	1
2	18, 24, 25	550630	Cover	1	45	15	004262	Spring Pin	1
2	2118, 2218	550631	Cover	1	50		Valve	Refer to Valve Escutcheon	1
2	21, 22, 31	550632	Cover	1	51	17,18**,2500, 25**	350946	Dual Pressure Control Ass'y.	1
2	24**, 25**	550629	Cover	1	53	8, 9	256508	Flow Control Valve	1
3		550109	Rotorshaft	1	55		450196	Volume Adj. Screw Ass'y.	1
3	12	550148	Rotorshaft	1	56	2400, 24**, 2500, 25**	350951	Dual Volume Control Ass'y.	1
3	21	550331	Rotorshaft	1	57	8, 9	256509	Union	1
3	22, 31	550332	Rotorshaft	1	58	18**, 24**	256510	Connector	1
4		450169	Port Plate	1	59	25**	256514	Run Tee	1
5		450127	Thrust Plate	1	60	18**,24**,25**	256742	Hose - 18" (Code 25** -Add 1)	1
6		350128	Pressure Ring	1	61	24**	350929	Adapter	1
7		252932	Vane Kit (Set of 26)	1	66		307182S	Name Plate	1
8		306197	Spring Seat	1	67		250597	Self-Tapping Screw	4
9		112927	Governor Spring	1	69	18**,24**,25**	198225	Soc. Hd. Cap Screw	4
10		129915	Follower Spring	1	70	18**,24**,25**	012144	Hi-Collar Lockwasher	4
11		251214	Ring Shoe Assembly	1	80*	21, 31	147655	Flange Cover (Shipping)	1
12		130041	Pin	1	80*	22	164598	Flange Cover (Shipping)	1
13		124389	Teflon Seal Ring	1	81	21	350663	Spline Coupling	1
14	Buna-N	124574	O-Ring	1	81	22, 31	350664	Spline Coupling	1
14	Viton	127746	O-Ring	1	82	22	450635	Adapter	1
15		125664	Teflon Seal Ring	1	82	31	450634	Adapter	1
16	Buna-N	108701	O-Ring	1	83	22	199682	Button Hd. Cap Screw	2
16	Viton	113215	O-Ring	1	85	Viton	167682	O-Ring	1
17	Buna-N	102556	O-Ring	1	85	21, 22, 31	138362	O-Ring	1
17	Viton	117505	O-Ring	1	86	Viton	144966	O-Ring	1
18		199670	Soc. Hd. Cap Screw	4	86	22, 31	144929	O-Ring	1
19		165219	Thrust Screw	1	87	31	258502	Threaded Rod	1
20		250368	Thrust Screw Plug	1	90*		254832	Flange Protector	1
21		121566	Bushing	2	91*		254831	Flange Protector	1
22		001396	Key	1	92		256708	SAE O-Ring Plug	1
23		105643	Dowel Pin	4	93		109376	Caplug (Shipping)	1
24		113988	Lip Seal (Codes 21/22 -Add 2)	2	94	31	199126	Hex. Nut	2
24	Viton	121587	Lip Seal (Codes 21/22 -Add 2)	2	95	21	008446	Caplug	2
25	Buna-N	153111	O-Ring	1	95	22, 31	008345	Caplug	2
25	Viton	162100	O-Ring	1	97*	12, 21, 22, 31	253841	Warning Tag	1
30		250240	Pressure Adj. Screw Ass'y.	1	98*		143391	Grease	A.R.
38	36	252152	Handwheel	1	99*		132779	LED Plate #250	A.R.
39	36	261323	Spring Pin	1					
40		004223	Spring Pin	1					

* Not Shown

PVR15-30B PARTS DRAWING

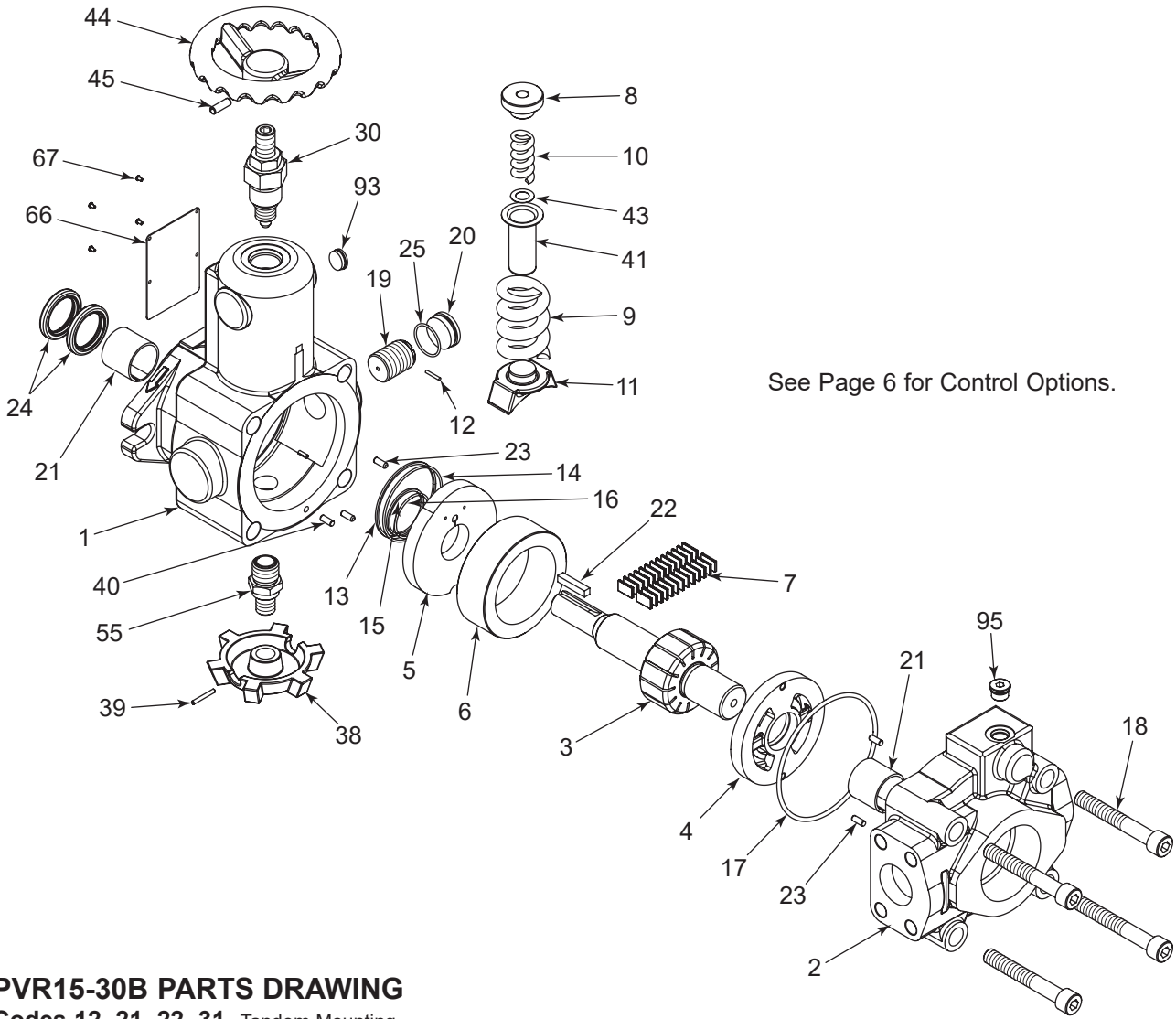

PVR15-30B PARTS DRAWING

Codes 12, 21, 22, 31 Tandem Mounting

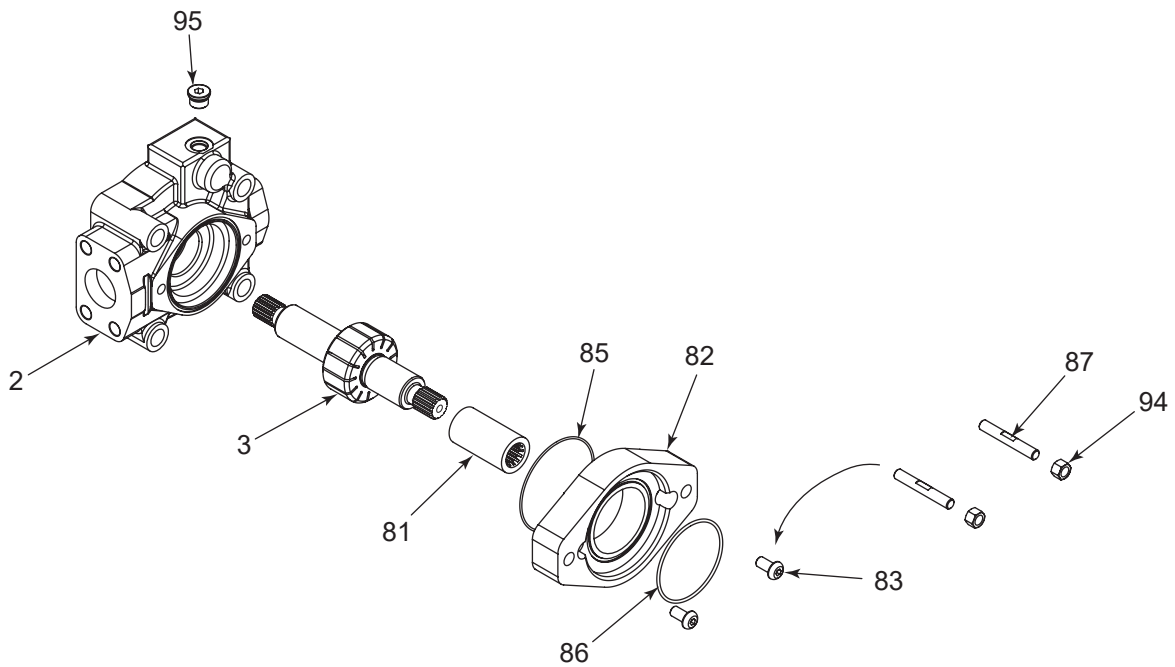

PVR15-30B PARTS DRAWING

Control Options

Code 17 Dual Pressure Control Without Integral Valve

Code 18** Dual Pressure Control With Integral Valve

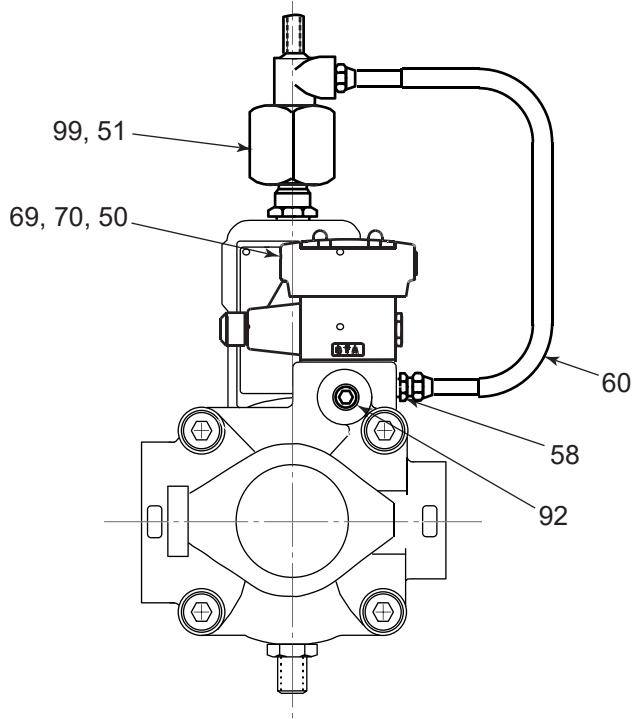

Code 2400 Dual Volume Control Without Integral Valve

Code 24** Dual Volume Control With Integral Valve

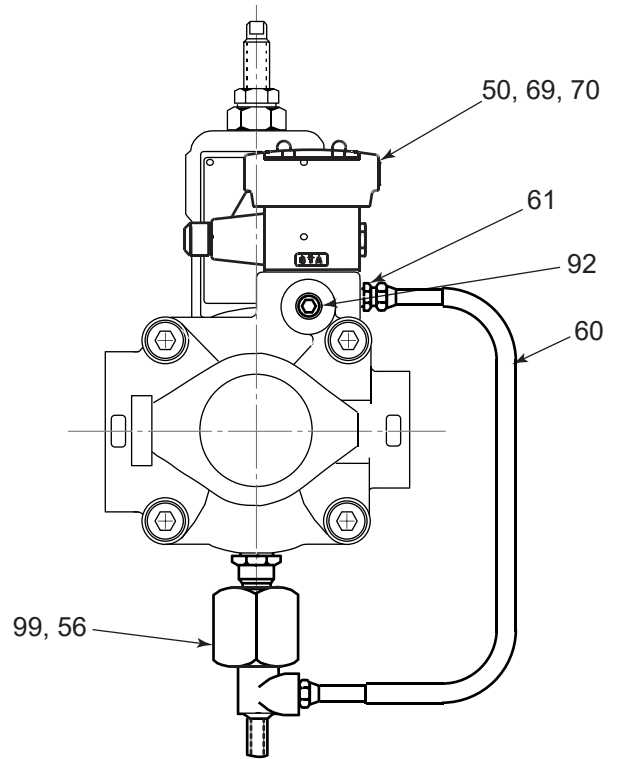

Code 2500 Dual Pressure/Volume Control Without Integral Valve

Code 25** Dual Pressure/Volume Control With Integral Valve

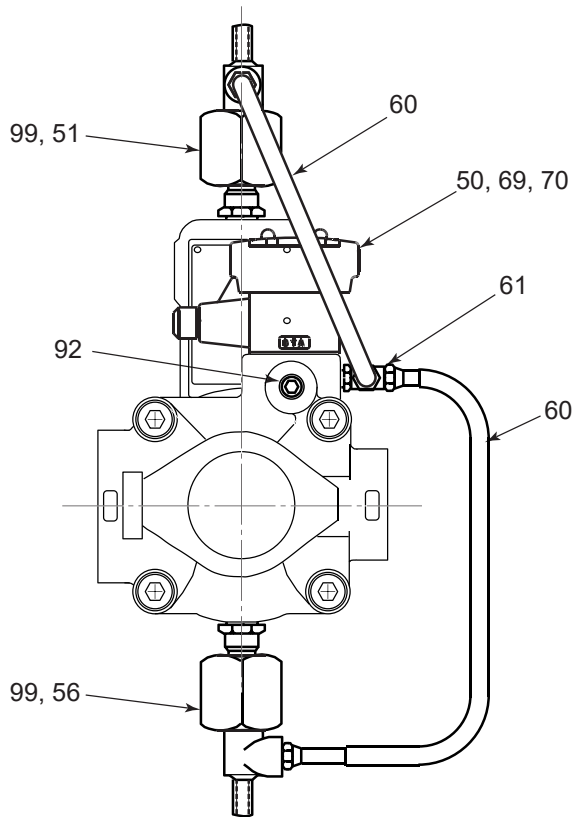

Code 8 Rate Control Valve for Dual Pressure

Code 9 Rate Control Valve for Dual Volume

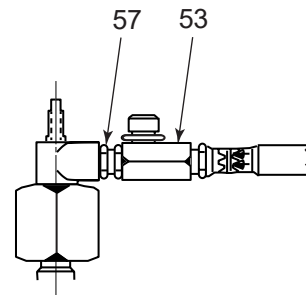

PVR15-30B PUMP REPAIR PROCEDURES

DISASSEMBLY PROCEDURE

NOTE: Disassembling a pump to change components, or for any other reason, may void the warranty. Refer to Policy Statement and Discounts Summaries.

1. Remove the key (22) in the rotor shaft keyway.
2. A small amount of oil may remain in the pump. Remove the four cover bolts (18) and slide the cover back far enough on the shaft to break the seal between the housing and cover to allow the pump to drain.
3. Remove the cover (2). Take care to avoid damage to the bearing with the end of the shaft when the cover is removed.
4. The port plate (4) may come out with the cover. Do not let it drop off the locating pins (23).
5. Remove the vanes (7) with a long nosed pliers or tweezers. There are two vanes in each slot, 26 vanes total.
6. Remove the rotorshaft (3) from the pump. Be sure that the key (22) has been removed from the keyway so that it will not damage the shaft seals when the rotorshaft is removed.
7. Turn the pressure adjustment screw (30) counterclockwise to release the tension on the governor spring.
8. Remove the pressure ring (6), ring shoe (11), governor spring (9), spring retainer (41) and follower spring (10).
9. If the lip seals (24) are to be removed they should be pushed out from the inside of the housing at this time. Care must be taken not to damage the journal bushing in the housing while the lip seals are being removed. It is recommended that the lip seals be replaced whenever the pump is disassembled for maintenance. The seals cannot be reused once they have been removed.
10. The journal bearings (21) in the pumps are assembled with a press fit. If they are to be removed at this time, the bushing in the housing should be pressed out from the front. The cover bushing should be pulled out using an expanding type puller. The bushings should not be reused once they have been removed.
11. It is unlikely that further disassembly will be necessary in order to perform routine maintenance on

the pump.

REASSEMBLY PROCEDURE

1. Clean and inspect parts to determine which parts are worn enough to require replacement.
2. Assemble the new journal bushings (21) in the housing and cover. The bushing OD's should be lubricated before they are pressed in the bores. Care must be taken to orient the "split" and the "oil groove" in the bushing as shown in the illustration below.

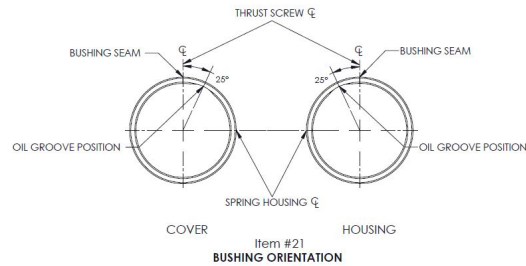

3. After the bushings are in place, check to see that the rotorshaft will fit into the bushings and provide a smooth turning fit. If the shaft turns hard, the bushings should be removed and the bore checked closely for nicks or burrs before pressing in the new bushings.
4. Check all of the replacement parts for nicks or burrs and then lubricate them with clean oil before reassembly.
5. Worn port and thrust plates should not be reground to clean up the wear surface. If the plates are ground, the assembly clearance will become excessive and the seal rings in the thrust plate may rupture. Replace worn port and thrust plates if necessary.
6. Assemble the springs (9, 10) and spring shoe (11), pressure ring (6) and rotorshaft (3).
7. To assure proper vane assembly, place the vanes (7) with the beveled edge out against the pressure ring.

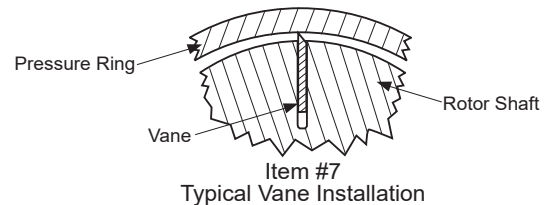

8. Assemble the four seal rings into the cavity in the back of the thrust plate. The soft rubber o-rings (14, 16) should be assembled first and the hard square seal rings (13, 15) should be assembled on top of them. Stretch the larger soft o-ring slightly so it clings to the ID at the cavity. Apply clean oil or STP to the back of the thrust plate before it is placed in the

PVR15-30B PUMP REPAIR PROCEDURES (Continued...)

locating pins in the body to help hold the parts together while they are assembled.

9. Before fitting the cover into the housing, check to assure that the bore in the port plate is concentric to the bearing bore in the cover. If the bores are not concentric, the port plate must be relocated 180° on the locating pins.

10. Assemble the cover (2) and port plate (4) onto the housing and align the bolt holes. Rotate the shaft as the bolts are tightened to assure that the vanes are not cocked.

11. Torque the cover bolts (18) to 100 lbs-ft. (135.6 Nm). The shaft should turn by hand when assembly is complete.

12. Lubricate the ID of the lip seals (24) and press them into the housing to the depth shown below. Note the "lip to the inside" orientation of the seals.

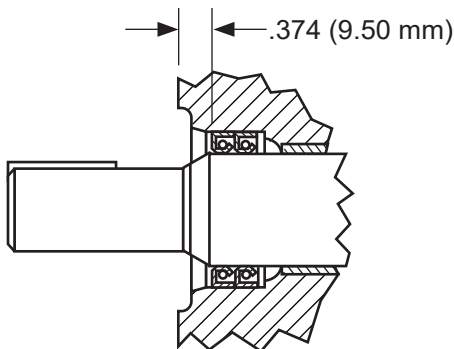

13. Adjust the pressure adjustment screw (30) until it just touches the spring and then give it one more turn clockwise.

14. Turn pump upside down. Pour one cup of good grade hydraulic fluid into the intake port while slowly rotating the shaft in the direction shown by the rotation arrow.

15. The pump is now ready to test. Refer to front of this manual for start-up procedure.

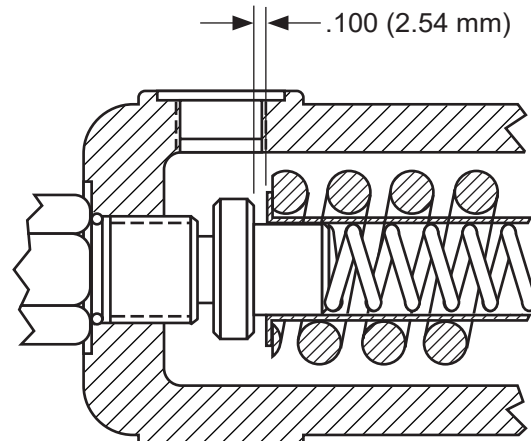

Continental Hydraulics
4895 12th Avenue East
Shakopee, MN 55379

Phone: (952) 895-6400 Fax: (952) 895-6444

www.continentalhydraulics.com

Because Continental Hydraulics is continually improving its' products, specifications and appearance are subject to change without notice.