

Brief operation manual

for pneumatically operated hydraulic pump type LP

acc to D 7280 and D 7280 H

1. Pneumatic and hydraulic connection

Pressure medium and pressure	Driving component (air side)	Compressed air prepared with usual commercial maintenance devices; Operating pressure $p_L = 1.5 \dots 10$ bar Water content in the air conforming ISO 8573-1 class 2 (3)			
	Pump component (hydraulic side)	Hydraulic oil 10 ... 68 mm ² /s (ISO VG 10 to VG 68 as per DIN 51 519) Viscosity range appr. 4 ... 1500 mm ² /s, opt. operat. appr. 10 ... 500 mm ² /s For perm. hydraulic pressure $p_{hydr.}$ see D 7280 (H)			
Maintenance unit	Commercially available maintenance devices, consisting of air filter (filter cartridge approx. 5µm) with water separator, pressure control valve (press, reducer), oiler and manometer are required for perfect preparation of compressed air and safe functioning of the pumps (see sect. 4)				
Temperatures	Compressed air:	+5 ... +40°C			
	Ambient:	-10 ... +40°C			
	Hydraulic fluid:	0 ... +80°C (see also sect. 5)			
Recommended size of the maintenance unit	Type	LP 80	LP 125	LP 160	
	Norm. flow \geq lpm	800	1600	2500	

2. Characteristic curve

Guideline figures for the pump delivery and pressure in dependance on the pneumatic pressure. The guideline figures for the air consumption are based on standard conditions.

2.1 Size LP 80

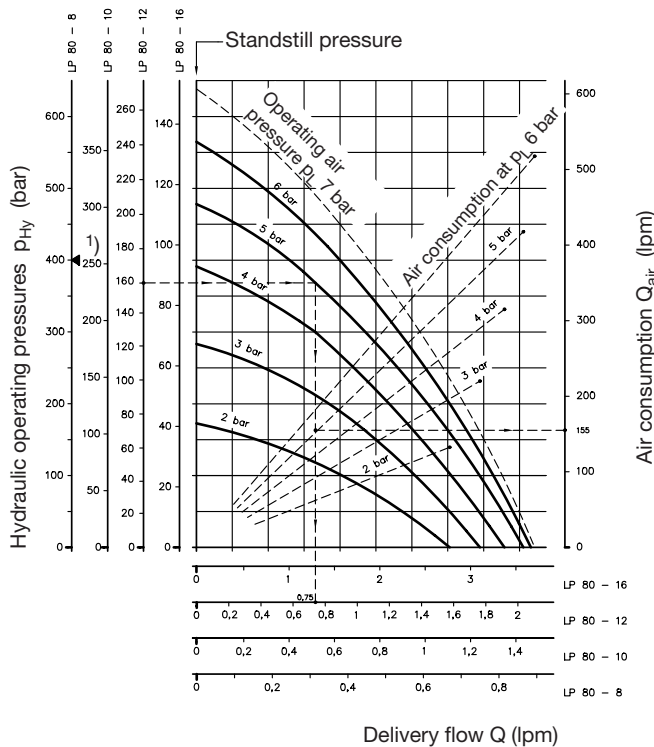

Basic type	Perm. pressure rating max.	
	Standstill pressure (bar)	Corresp. pneum. pressure (bar)
8	700	7.1
LP80- 10	630	10
12	430	
16	240	

$p_L = p_{pneum.}$

1) This reduced max. permissible pressure rating for the standard version is caused by the common pressure outlet port P. This also applies to hydraulic power packs acc. to D 7280 H



1800-OILSOL
1800-645765

<https://oilsolutions.com.au/>

sales@oilsolutions.com.au



HAWE HYDRAULIK SE
EINSTEINRING 17 • 85609 ASCHHEIM/MÜNCHEN

B 7280
Operation manuel pump LP

2.2 Size LP 125

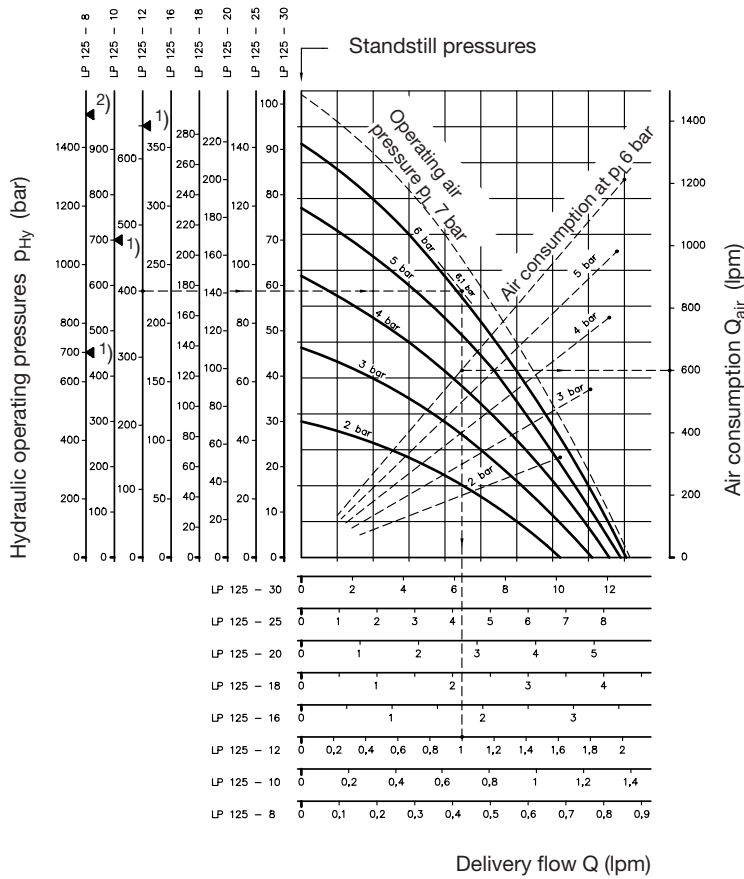

Basic type	Perm. pressure rating max.	
	Standstill pressure (bar)	Corresp. pneum. pressure (bar)
8	700/(1500) ²⁾	2.9/ (6.2) ²⁾
10	700/(1500) ²⁾	4.5/ (9.7) ²⁾
12	700	6.5
LP125-16	600	10
18	470	
20	380	
25	240	
30	160	

p_L = p_{pneum.}

- 1) This reduced max. permissible pressure rating for the standard version is caused by the common pressure outlet port P. This also applies to hydraulic power packs acc. to D 7280 H
- 2) For the max. permissible pressure for version ...-8E and ...-10E (without piping)

2.3 Size LP 160

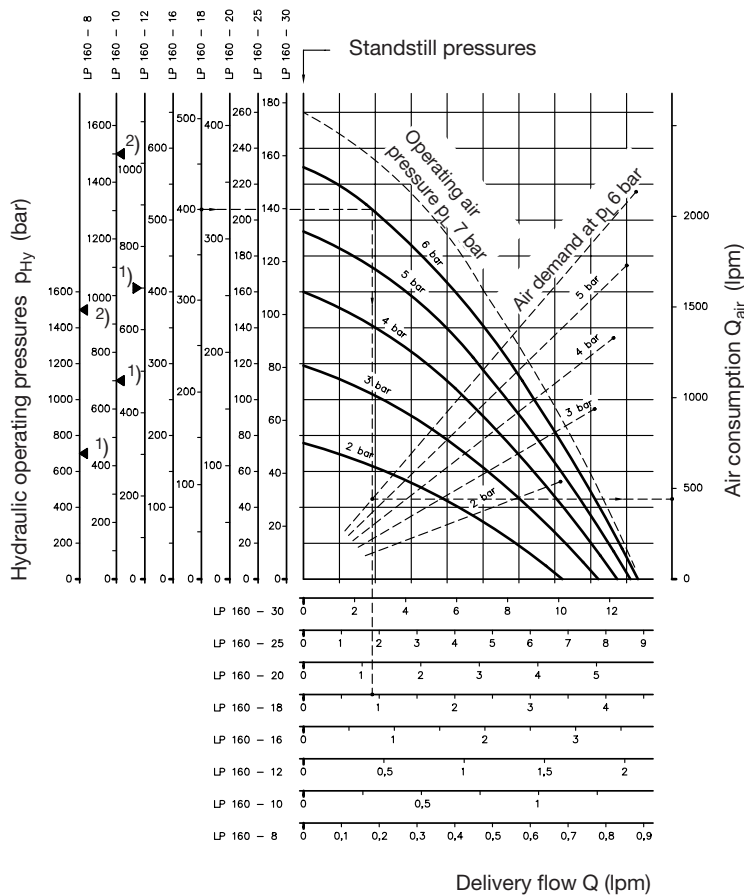

Basic type	Perm. pressure rating max.	
	Standstill pressure (bar)	Corresp. pneum. pressure (bar)
8	700/(1500) ²⁾	1.8/ (3.8) ²⁾
10	700/(1500) ²⁾	2.8/ (5.9) ²⁾
12	700	4
LP160-16		7.1
18		9.2
20	620	10
25	390	
30	265	

p_L = p_{pneum.}

- 1) This reduced max. permissible pressure rating for the standard version is caused by the common pressure outlet port P. This also applies to hydraulic power packs acc. to D 7280 H
- 2) For the max. permissible pressure for version ...-8E and ...-10E (without piping)



3. Mounting instruction

Installation position like illustrated in the dimensional drawings (i.e. suction ports down, pressure ports and muffler up) as this eases automatic bleeding of the hydraulic pump elements. A lateral or downward orientation is also possible, see sect. 3.2.2).

3.1 Installation in customer-furnished oil tanks

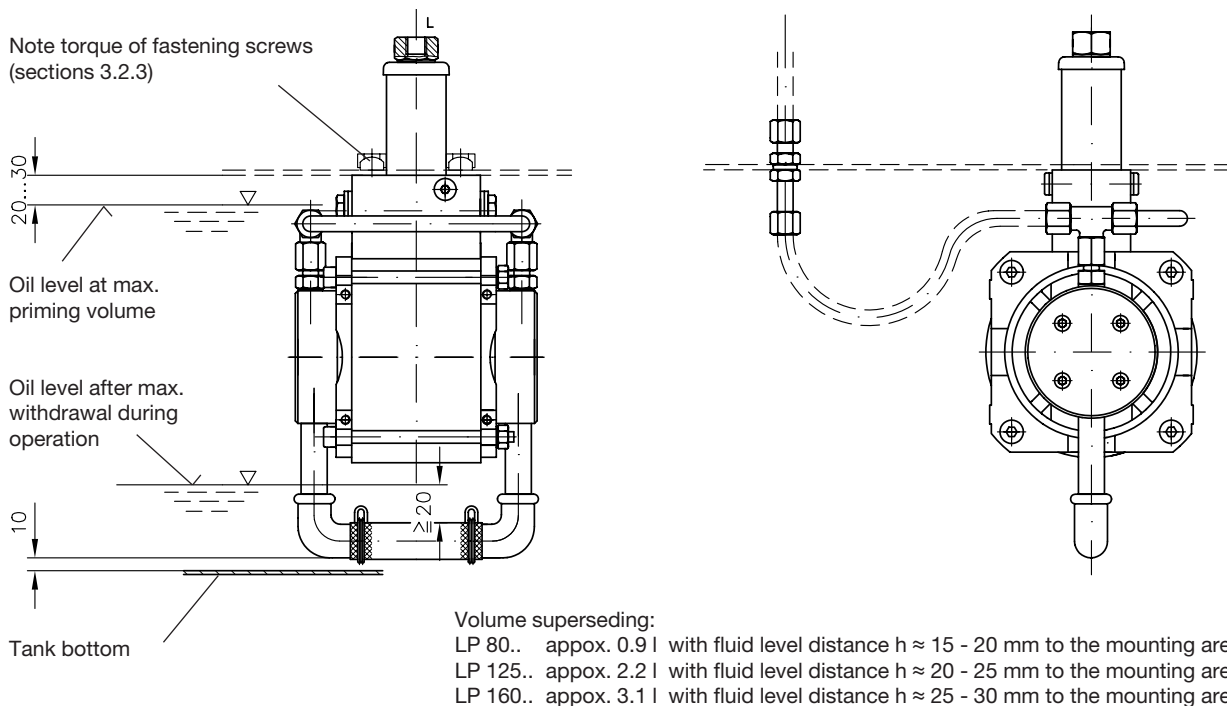

3.2 Installation outside an oil tank

Position the pump in such a way that the oil level is always within the area of the upper half of the pump or higher. The pump should not be installed at a position where it is permanently above the fluid level. This would involve use of foot valves to prevent the suction pipe from running empty during prolonged stand-still periods. Place the opening of the return pipe below the lowest expected oil level. The suction pipes must be well sealed (see also section 5.3).

3.2.1 Usual arrangement, with pump in factory adjusted original condition

Two possible fastening methods (for fastening thread, see section 3.2.3)

Hanging position, using fastening thread B 1; note torque (sect. 3.2.3)

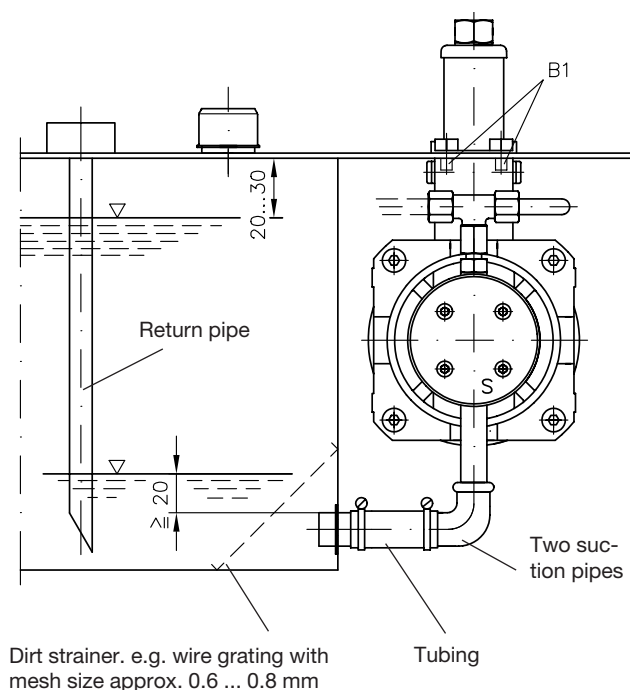

Side position, using fastening thread B 2

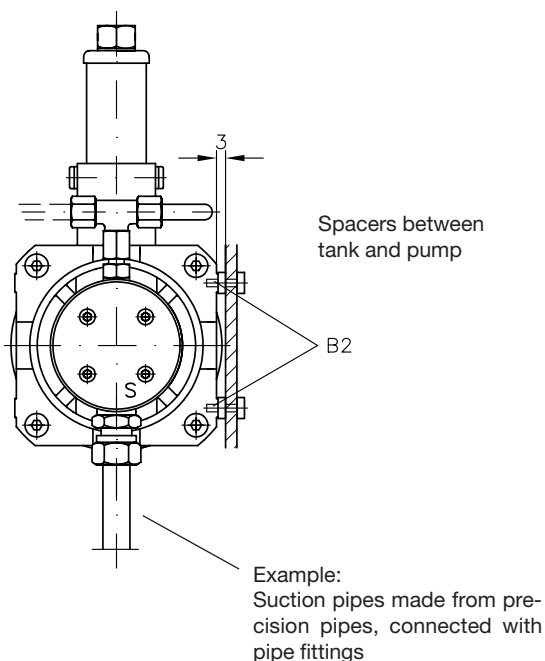

3.2.2 Silencer position horizontal or downward

While taking into consideration the best position for the suction pipes, or in special operating circumstances as in sect. 5, the pump cylinders can be turned by 90° in to different positions after loosening the screws ①. Restriction for LP 80: The pump can only be installed laterally like in illustration a) as complete unit (state of delivery). It is not possible to rotate the hydraulic cylinders in relation to the pneumatic cylinder. The other installations like illustration b) or below are not possible due to design reasons.

Pump position with horizontal suction connection

a) Pump, as assembled by HAWE

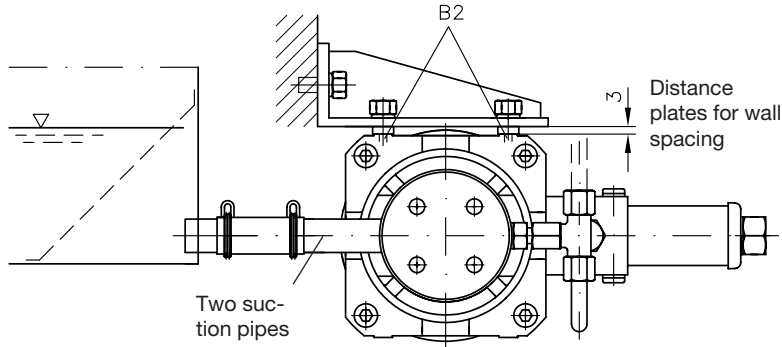

Pump position with suction connection entering vertically from bottom to top

Pump mounted with cylinders turned by 180°

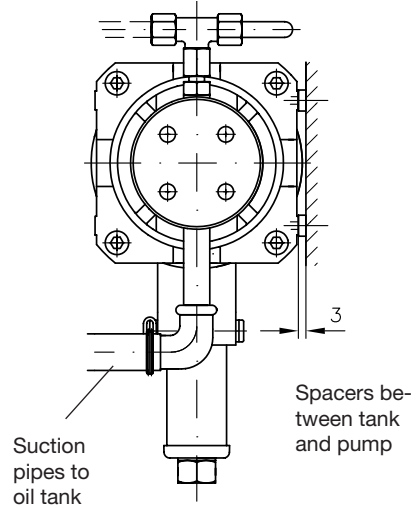

b) Pump mounted with cylinders turned by 90°

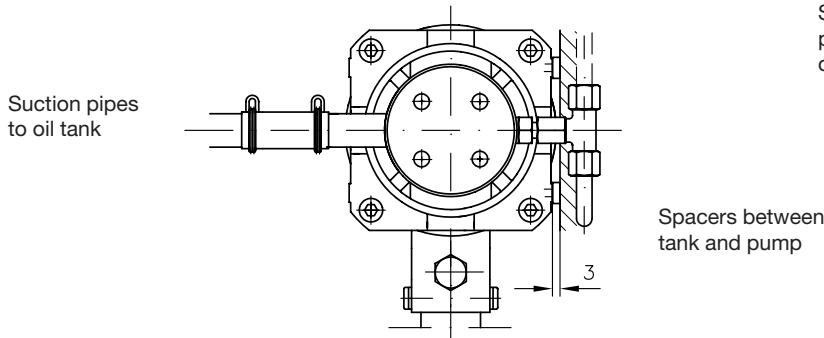

3.2.3 Dimensions for mounting and piping

	Fastening thread		Max. torque (Nm)	Compressed air connection (BSPP)	Pressure port P1/P2 (BSPP)	Suction port (BSPP)
	B 1	B 2				
LP 80	M8,15 deep	M6,12 deep	19	G 1/4	G 1/4	G 3/8
LP 125 8-16	M8,15 deep	M6,12 deep	23	G 3/8	G 1/4	G 1/2
18-30					G 3/8	
LP 160 8-16	M8,15 deep	M8,15 deep	23	G 1/2	G 1/4	G 1/2
18-30					G 3/8	



4. Compressed air connection and initial operation

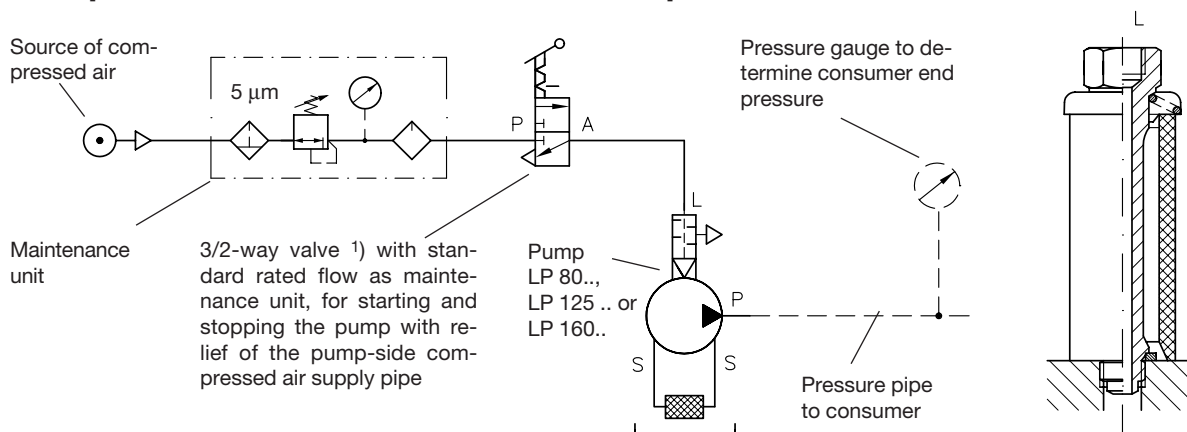

1. Set the pressure reducing valve on the maintenance unit to the lowest supply air pressure (approx. 1.5 bar). The air start valve should be on stop.
2. Loosen the pressure pipe at the consumer sufficiently so that enclosed air can escape. Open the air start valve and wait for the oil to come.
3. Air start valve on stop. Tighten the pressure pipe, and after starting the pump again, pressurize the unloaded consumer several times and move it to and fro. Then turn the pressure reducing valve up as in 1 to required supply air pressure (step by step if necessary), until the desired end pressure, e.g. standstill pressure, is shown on the manometer of the pressure pipe to the hydraulic consumer.

The maintenance unit in the compressed air supply pipe is obligatory, since it alone ensures smooth operation by filtering, moisture separation and oiling (= preparation of compressed air). It has a pressure reducing valve to limit the air pressure, which is necessary on the hydraulic side to fix the standstill pressure.

Attention: Observe the max. air pressure rating for air pumps piped by HAWE!

A pressure reducing valve has to be used when the pump is supplied via compressed air cylinders. The pumps type LP do not feature any pressure valve on the pneumatic side!

Any industrial standard hydraulic oil (ISO VG 10) or spindle oil (ISO VG 5 to 10) may be used in the pneumatic maintenance unit. The dynamic seals of piloting and main plunger of the reversal control valve should be lubed regularly when connected to oil-free pneumatics and frequent every-day use is intended. Suited are longterm lubes e.g. Autol TOP 2000 from Co. Autol, Paradiesstraße 14, D-97080 Würzburg.

The maintenance intervals depend on the individual operation conditions e.g. a 3-4 month interval for 3-shift permanent operation. See also notes in sect. 5

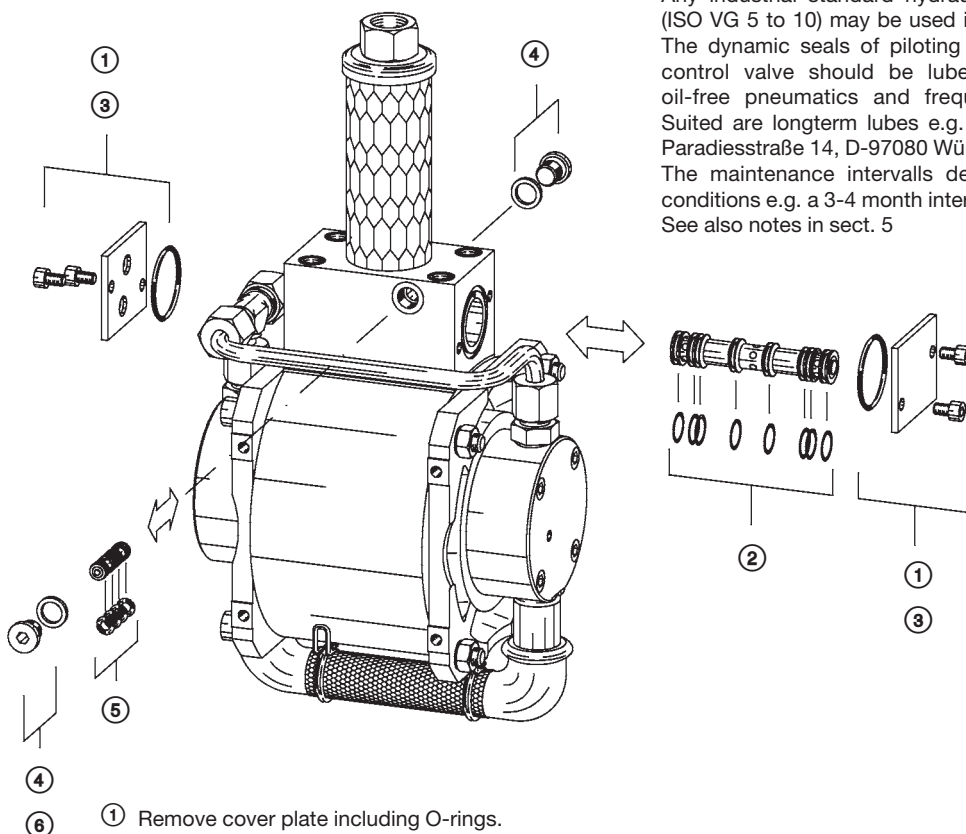

- ① Remove cover plate including O-rings.
- ② Push out the main plunger (any side) the sleeve remains in the housing.
Lube the visible sections of the O-rings.
Reinstall the plunger in the housing (sleeve).
- ③ Reinstall the cover plate including O-rings.
- ④ Remove the tapped plugs including the copper seal rings.
- ⑤ Push the piloting plunger (any side) out of the housing.
Lube the visible sections of the O-rings.
Reinstall the plunger in the housing.
- ⑥ Reinstall the tapped plugs including the copper seal rings.

1) Industrial standard pneumatic reducers can be installed at port L, if the thread of port A at the pneumatic directional valve and port L at the air driven pump type LP are differing. The largest possible diameter for the air line should be used always.

5. Supplementing note for prolonged operation periods

Any pressurized gas (or gas mixture) will cool down due to the thermodynamic regularity, when decompressed suddenly (adiabatic). This will cause also cool down of the surrounding material where the decompression happens and where the gas is routed through. The stand still periods during normal usual working cycles are usually sufficient that these components come to ambient temperature again.

But white frost or internal icing may occur (dep. on the moisture in the compressed air), when the pump is running for prolonged periods. This effect is also visible at other pneumatic tools where the working speed is cut down and even stand-still is caused by iced control elements. Pumps type LP are prone to such malfunction when permanently operated for more than 20 minutes and air pressure is higher than 4 bar. A good preventive measure is adding anti-freeze-lubricant (like for truck brakes) in the service unit of the compressed air. This will cut down the freezing point and will additionally lube the dynamic (moving) seals on the pneumatic side of the pump. It is advantageous to install the pump with the silencer directing sideward or downwards as any excess antifreeze condensing at the silencer will drop down and not drip into the movement reversal valve again. Evidently this is not possible with complete hydraulic power packs from HAWE as the silencer is always vertically upwards.

Freezing of the pump components may happen when the air to drive the pump is too cold (below the perm. temperature range). This may happen especially when cylinders are used as source but also when the pump is running over prolonged periods, as compressed gases cool down strongly, when decompressed.

A recommended anti-freeze-lubricant is e.g. „Klüberbio LR 6-15“ from Co. Klüber Lubrication, D-81379 München, Geisenhausenerstr. 7.

5.1 Optional leakage drain with type LP 125 and LP 160

A drain line is necessary, when the pump is installed outside the tank and any leakage (drops only) are not permissible or unwanted, e.g. due to clean room conditions etc.

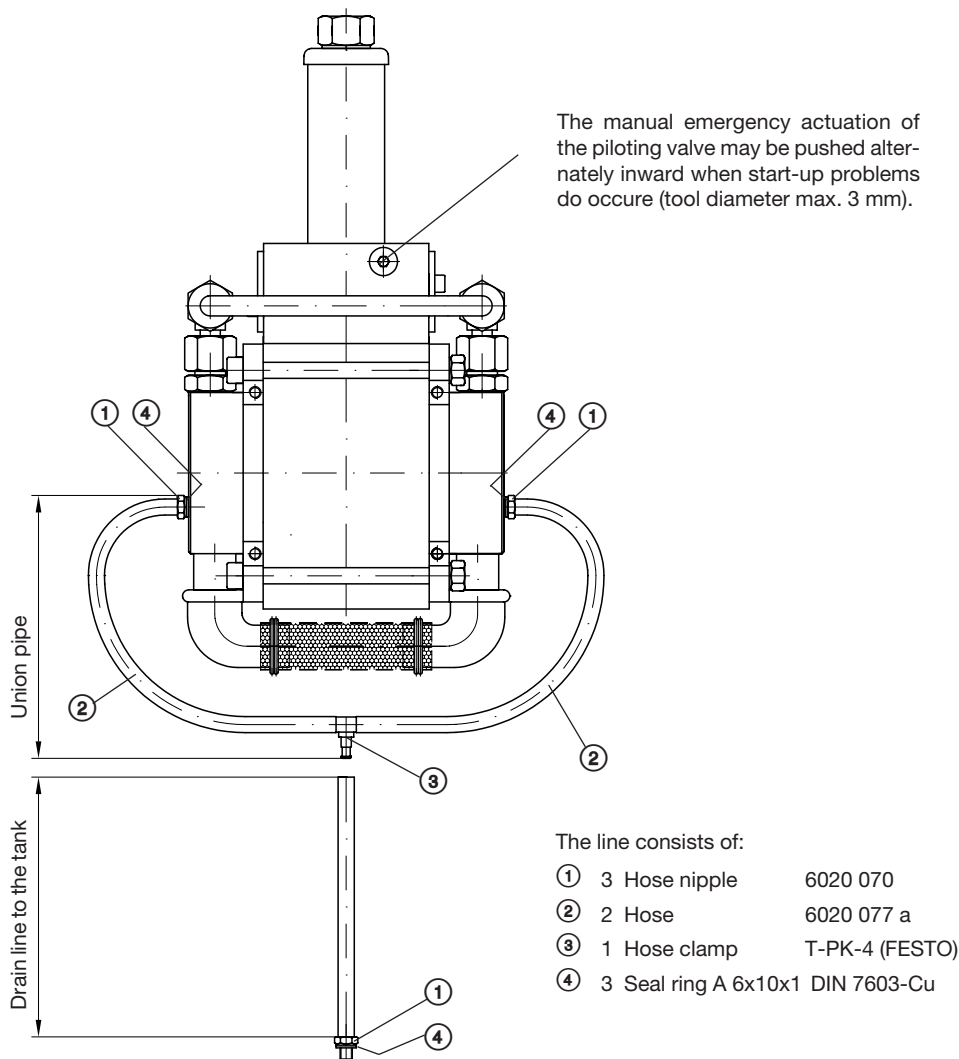

München, 01.08.2012



1800-OILSOL
1800-645765

<https://oilsolutions.com.au/>

sales@oilsolutions.com.au

Declaration of Incorporation within the meaning of the Machinery Directive 2006/42/ EC, appendix II, No.1 B

Compact hydraulic power pack type LP acc. to our pamphlet D 7280 (latest release)

is an incomplete machine (acc. to article 2g), which is exclusively intended for installation or assembly of another machinery or equipment.

The specific technical documents, necessary acc. to appendix VII B, were prepared and are transmitted in electronic form to the responsible national authority on request.

Risk assesment and analysis are implemented according to appendix I of the Machinery Directive.

The dept. MARKETING is authorized to compile the specific technical documents necessary acc. to appendix VII B

HAWE Hydraulik SE
Dept. MARKETING
Einsteinring 17
D-85609 Aschheim/München

The following basic safety and health protection requests acc. to appendix 1 of below guideline do apply and are complied with:

DIN EN ISO 4413:2010 of November 2010

"Hydraulic fluid power – General rules and safety requirements for systems and their components"

We assume that the delivered equipment is intended for the installation into a machine.

Putting in operation is forbidden until it has been verified that the machine, where our products shall be installed, is complying with the Machinery Directive 2006/42/ EC.

This Declaration of Incorporation is void, when our product has been modified without our written approval.

HAWE Hydraulik SE

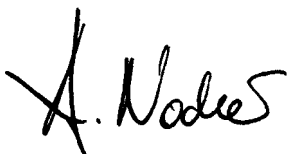

i.A. Dipl.-Ing. A. Nocker (Produktmanagement)