

# Hydraulic power pack type LP

Turn-key version including tank  
with air driven hydraulic pump acc. to D 7280

Displacement	$V_{\max \text{ geom.}} = 28.3 \text{ cm}^3/\text{double stroke}$
Delivery flow	$Q_{\max \text{ hydr.}} = \text{approx. } 12 \text{ lpm}$
Operating pressure	$p_{\max \text{ hydr.}} = 1500 \text{ bar}$
	$p_{\max \text{ air}} = 10 \text{ bar}$
Tank filling volume	$V_{\max \text{ tank}} = 33 \text{ l}$



## Cover plate

version for customer furnished tank, here with connection block type C 5 for direct pipe connection.

Order example and flow pattern symbol

**LP 125-12 / D4-C5**

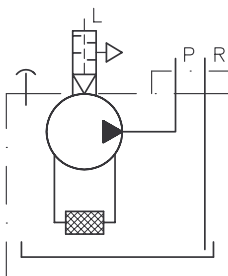

## Hydraulic power pack

with directly mounted directional seated valve type VB 11 acc. to D 7302

Order example and flow pattern symbol

**LP 125-16 / B4 - VB 11LP - HHH - 1**

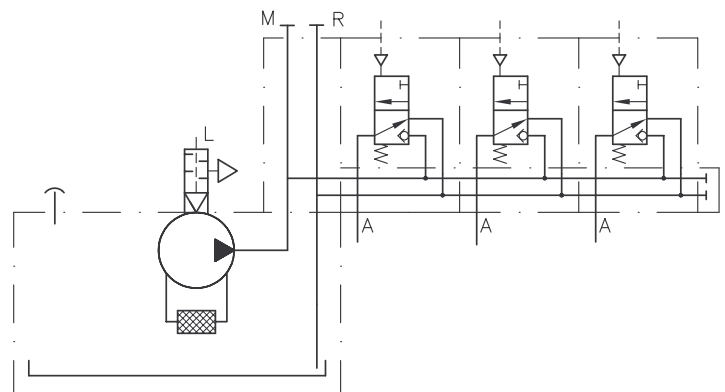

## 1. General information

- Hydraulic power pack without connection block (retrofit) or with connection block for direct pipe connection
- Hydraulic power pack with connection block and directly mounted directional seated valve bank.

The connection blocks are available with/without pressure limiting valve.

There is usually no pressure limiting valve necessary for the hydraulic side, when the pneumatic pressure is set at the pressure reducing valve of the pneumatic maintenance unit accordingly to the hydraulic consumer specification. The pump will automatically come to a stand-still and restart depending on the pressure level at the hydraulic side. A connection block with a pressure limiting valve has to be utilized when a specific pressure on the hydraulic side must be maintained without altering the pressure on the pneumatic side e.g. necessary when several consumers are driven from one pneumatic source. Drawback is that the pump will run permanently with all excess delivery being returned to the tank via the pressure limiting valve on the hydraulic side. The pump will come to a stop only when the pneumatic side is cut-off via a on/off valve.



1800-OILSOL  
1800-645765

<https://oilsolutions.com.au/>

sales@oilsolutions.com.au

**HAWE**  
HYDRAULIK

HAWE HYDRAULIK SE  
STREITFELDSTR. 25 • 81673 MÜNCHEN

**D 7280 H**  
Hydraulic power pack type LP

## 2. Available versions, main data

Order examples:

LP 160 - 25 / **B 25**  
 LP 80 - 8 / **B 4 C 5**  
 LP 125 - 18 / **B 10** - **BWH 1 L-NN-33-1-G24**  
 LP 125 - 12 / **B 4 S A1/400 - VB 11 SP-HHH-1**

Basic pump acc. to D 7280



**Table 1a:** Tank size

Coding Container	Slab	Filling-volume approx. (l)	Usable volume approx. (l) <sup>4)</sup>	Mass (weight) approx (kg) <sup>1)</sup>	Suitable for combination with basic pump (D 7280)
<b>B 4</b>	<b>D 4</b>	7	5 (4.7)	5.7	LP 80-16 to -8
		5.8	4 (3.8)		LP 125-30 to -8
<b>B 10</b>	<b>D 10</b>	16.6	13.5 (13.3)	8.5	LP 125-30 to -8
		13.5	11.5 (11.4)		LP 160-30 to -8
<b>B 25</b>	<b>D 25</b>	34	29	15.1	LP 125-30 to -8
		33	28		LP 160-30 to -8

**Table 3:** Direct mounting of directional valve banks

<b>Direct mounting</b> (no pressure limiting valve)	
Directional seated valves type	
BWN 1L..	acc. to D 7470 B/1
BWH 1L..	(solenoid actuated)
VB 01L..	acc. to D 7302
VB 11L..	(with various actuations)
<b>Mounting via connection block</b> (with pressure limiting valve)	
Type A.. (see table 2)	
Directional seated valves type:	
BWN 1S..	acc. to D 7470 B/1
BWH 1S..	(solenoid actuated)
VB 01S..	acc. to D 7302
VB 11S..	(with various actuations)

**Table 1b:** Optionally with float switch or level gauge

	NO-contact	Technical data:	B4, B10	B25
<b>S</b> <sup>5)</sup>		Max. switch capacity DC/AC Max. current DC and AC	60W / 60VA 0,8 A (cos φ = 1)	30W / 30VA 0,5 A
<b>D</b>		Max. voltage Temperature range	230V 50 a. 60 Hz -10 ... +80°C	230V 50 a. 60 Hz -10 ... +80°C
<b>K</b> <b>(K1, K2)</b>	Level gauge (For different position, see page 3)			

A protective circuitry has to be provided for inductive load.

**Table 2:** Connection blocks

Coding	acc. to pamphlet	Tapped ports conf. DIN ISO 228/1 (BSPP)	Pressure range p <sub>max</sub> from ... to (bar) <sup>2)</sup>	Flow Q <sub>max</sub> (lpm)	Integrated functional elements		Brief description
					Pressure limiting valve	Optional check valve	
no coding	Customer furnished connection block; for hole pattern see sect. 3.1						
<b>C 5</b>	D 6905 C	G 1/4	700	12	no	no	Basic connection block
<b>C 6</b>		G 3/8		28			
<b>B.../...-...</b>	D 6905 B	G 1/4	450 (700)	8 ... 25	yes	yes	For single acting lifting or clamping devices
<b>A 1/... A 2/...</b>	D 6905 A	G 1/4	(0) ... 700 in steps	12	yes	no	Most frequently used connection blocks with pressure limiting valve
<b>A 3/... A 4/...</b>					yes	yes	
<b>AP 1... AP 3...</b>					D 6905 AP	G 1/4	
<b>AX 14... and AX 3...</b>	D 6905 TÜV	G 1/4 and G 3/8	80 ... 450	6 ... 10	yes	yes	Pressure limiting valve with unit approval

- 1) Tank complete (cover plate, tank and piping) without pressure fluid. For basic pump, see D 7280
- 2) Max. perm. pressure with type LP 80 is 400 bar as standard hydraulic power pack (see D 7280, sect. 2.1). Observe the max. pressure rating of the directly mounted directional valve banks it might be rated lower than 700 bar.
- 3) May be used also as idle circulation valve (approx. 5 bar) when the prop. solenoid is deenergized. Idle circulation circuits via solenoid actuated valves may be useful for frequently changing load/no-load periods within one cycle, where it is not practical to start and cut-off the pump for seconds only. In this case the pump will be cut-off after the cycle has been completed
- 4) The figures in brackets represent the approx. consumable volume, after which the float switch triggers a signal (table 1b).
- 5) Only avail. for tank B4 and B10



### 3. Unit dimensions

All dimensions in mm, subject to change without notice!

#### 3.1 Hydraulic power pack (basic unit without connection block)

See sect. 3.2 for versions with connection blocks and sect. 3.3 for versions with directly mounted directional valve banks!

**Type LP 80 -.. /B 4 (D 4)**  
**LP 125 -.. /B 4 (D 4)**

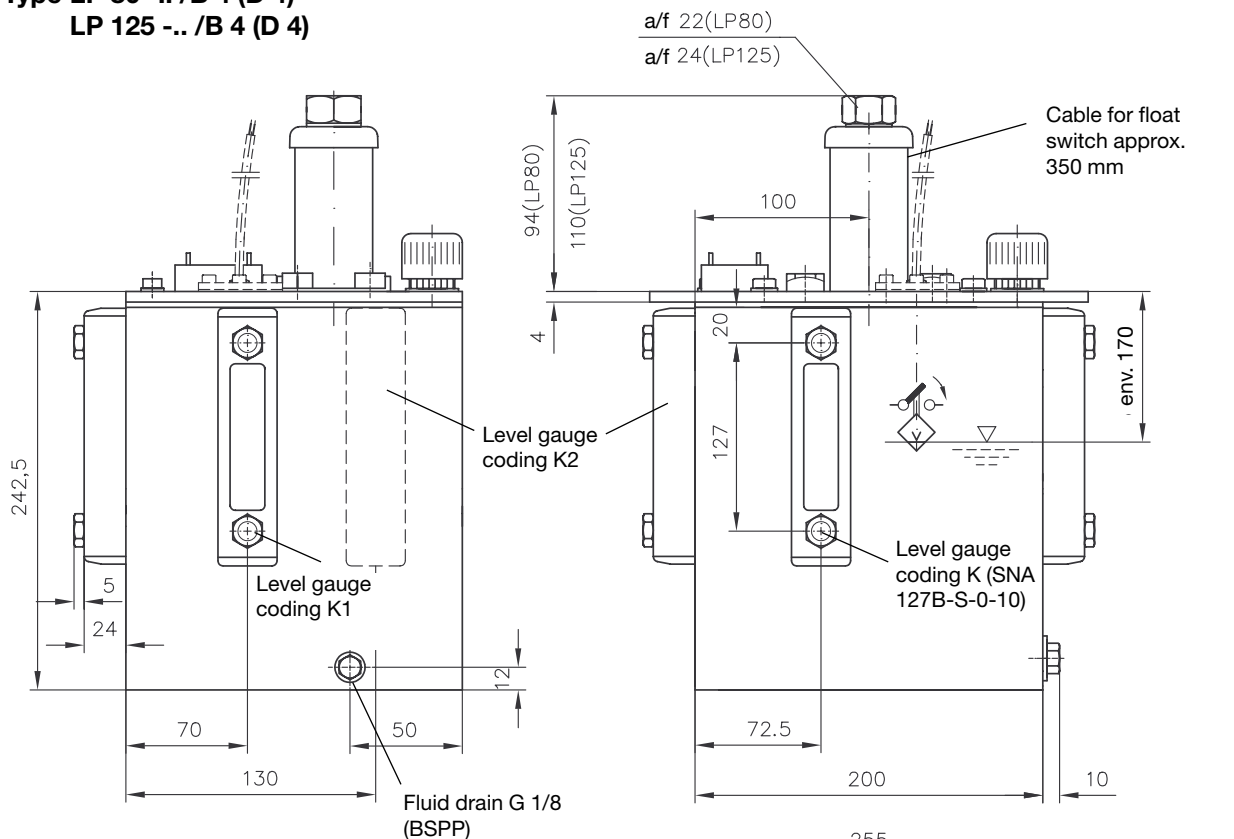

Hole pattern of the connection flange for mounting of a customer furnished connection bloc

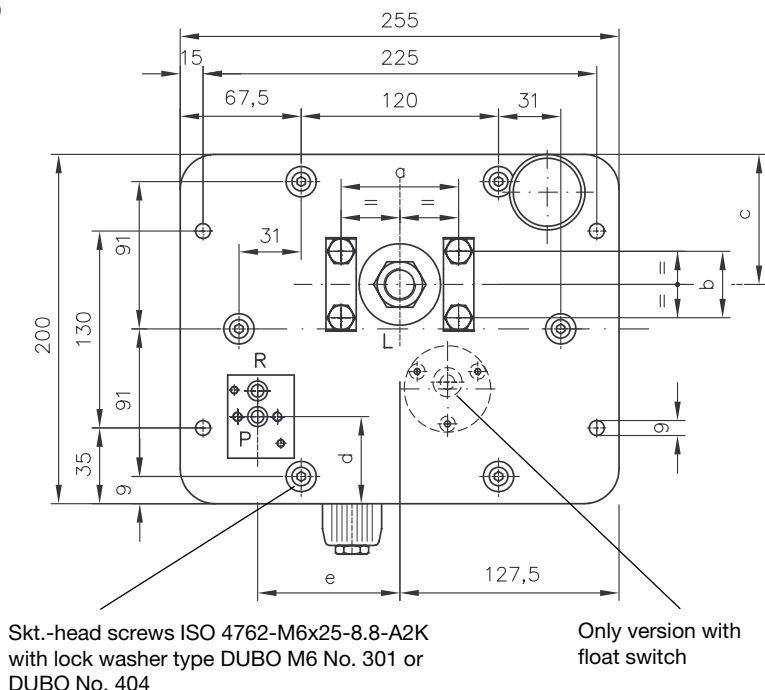
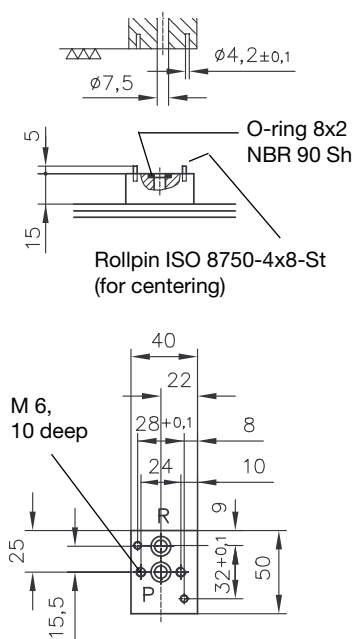

P = Pressure port (BSPP)  
 R = Return port (BSPP)  
 L = Pneumatic port G 1/4 (LP 80) (BSPP)  
 G 3/8 (LP 125) (BSPP)

Type	a	b	c	d	e
LP 80	55	26	80	45	75
LP 125	62	35	75	55	77



1800-OILSOL  
 1800-645765

<https://oilsolutions.com.au/>

[sales@oilsolutions.com.au](mailto:sales@oilsolutions.com.au)

Type LP 125 -.. /B 10 (D 10)  
LP 160 -.. /B 10 (D 10)

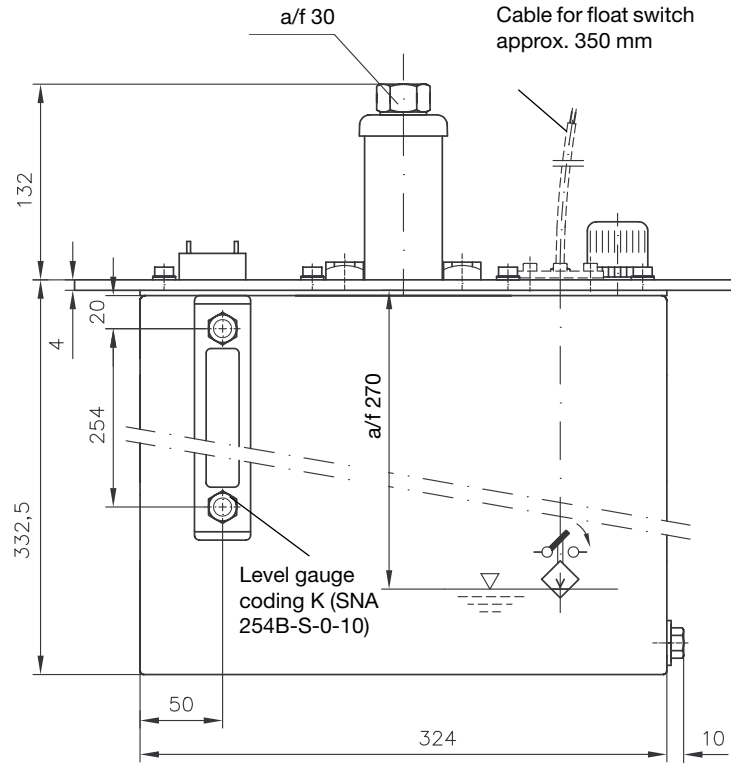
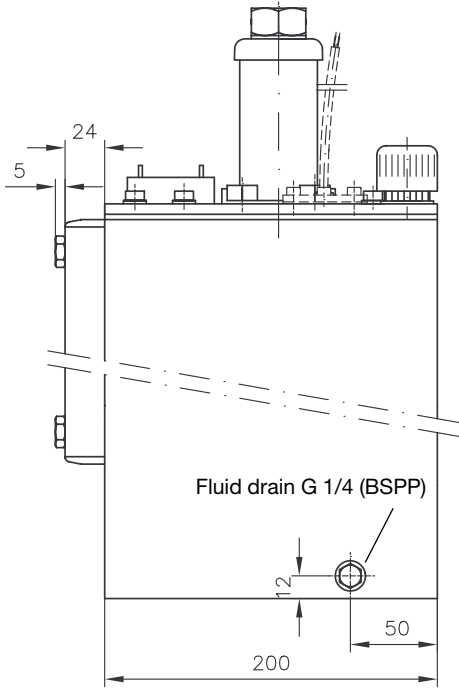

Hole pattern of the connection flange for mounting of a customer furnished connection bloc

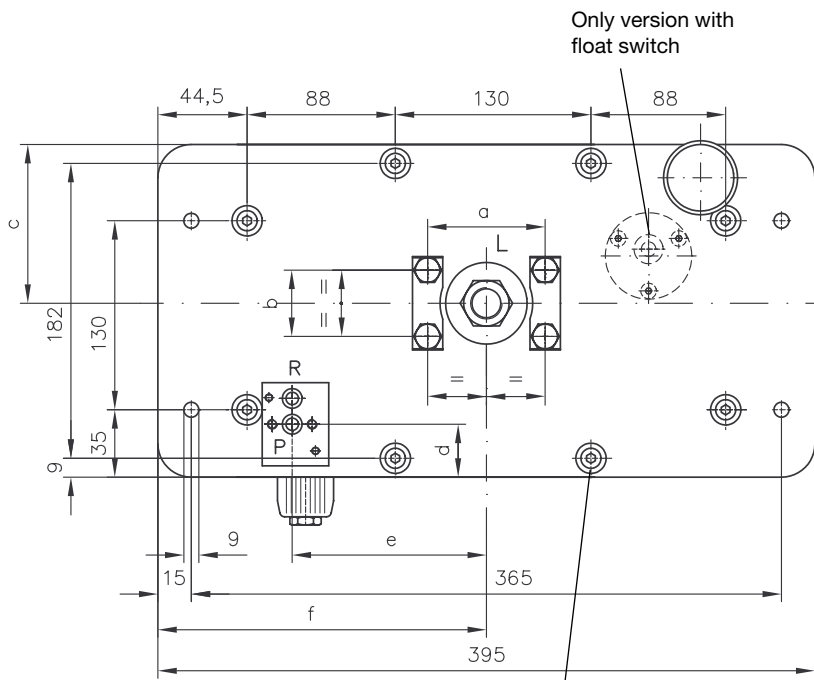
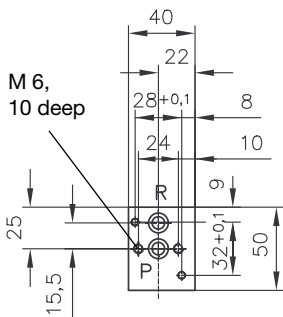
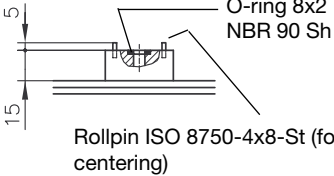
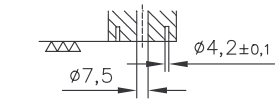

Skt.-head screws ISO 4762-M6x25-8.8-A2K with lock washer type DUBO M6 No. 301 or DUBO No. 404

P = Pressure port (BSPP)  
R = Return port (BSPP)  
L = Pneumatic port G 3/8 (LP 125) (BSPP)  
G 1/2 (LP 160) (BSPP)

Type	a	b	c	d	e	f
LP 125	62	35	75	55	77	155
LP 160	68	45	95	36	122,5	197,5



1800-OILSOL  
1800-645765

<https://oilsolutions.com.au/>

sales@oilsolutions.com.au

**Type LP 125 -.. /B 25 (D 25)**  
**LP 160 -.. /B 25 (D 25)**

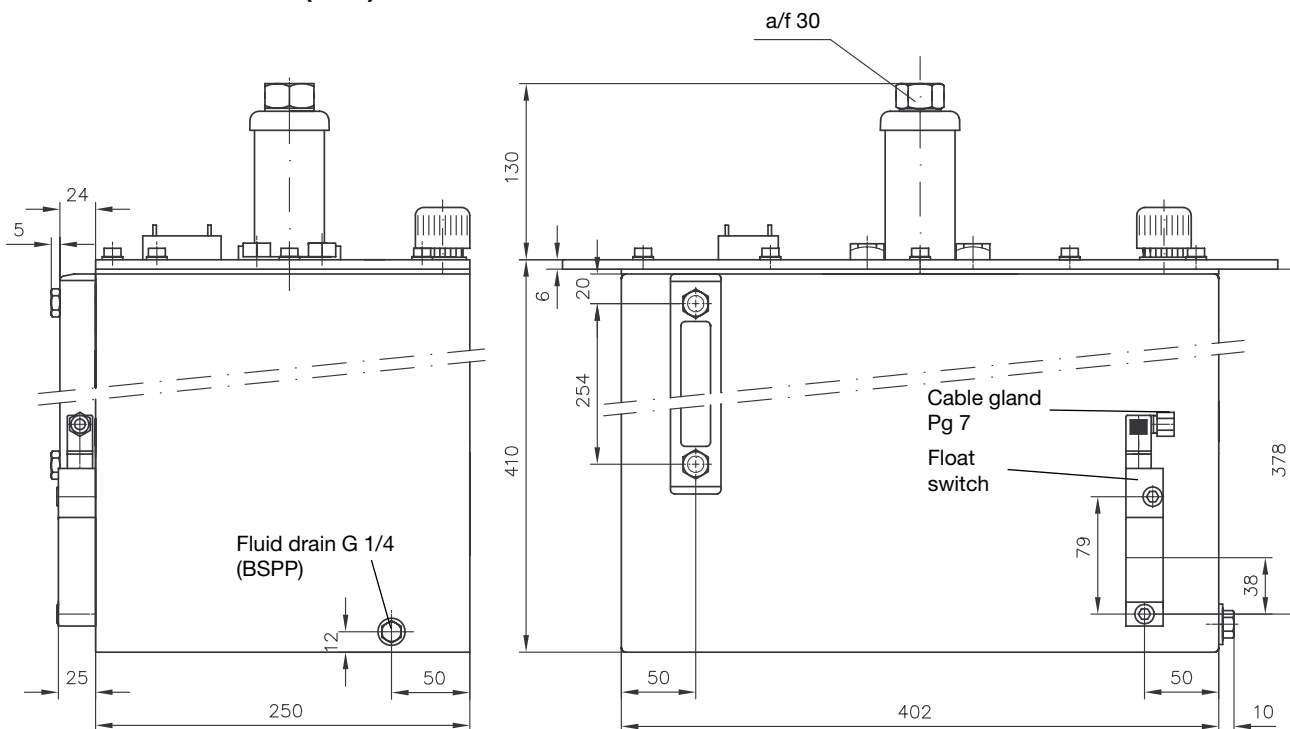

Hole pattern of the connection flange for mounting of a customer furnished connection bloc

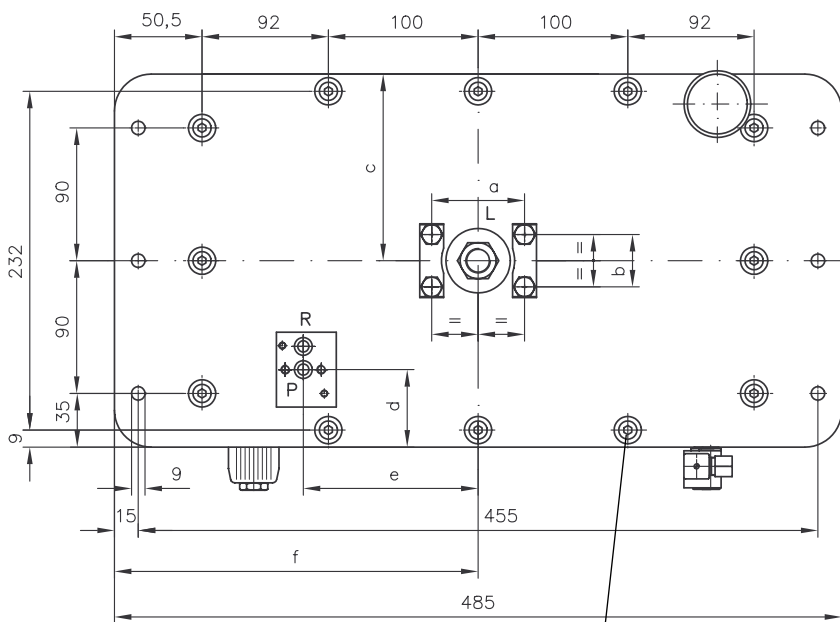
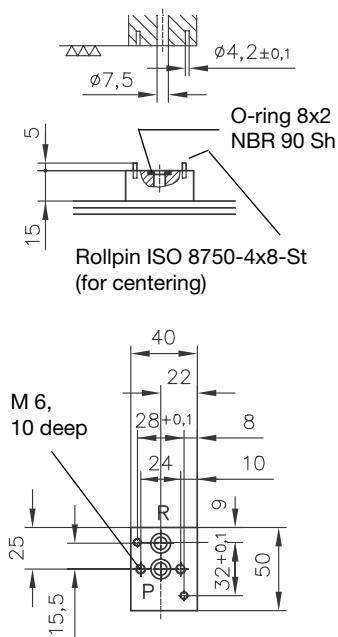

P = Pressure port (BSPP)  
 R = Return port (BSPP)  
 L = Pneumatic port G 3/8 (LP 125) (BSPP)  
 G 1/2 (LP 160) (BSPP)

Skt.-head screws ISO 4762-M6x25-8.8-A2K with lock washer type DUBO M6 No. 301 or DUBO No. 404

Type	a	b	c	d	e	f
LP 125	62	35	75	105	77	155
LP 160	68	45	125	56	122.5	242.5



1800-OILSOL  
 1800-645765

<https://oilsolutions.com.au/>

sales@oilsolutions.com.au

### 3.2 Connection blocks

Version  
without pressure limiting valve

**Type C 5 and C 6**

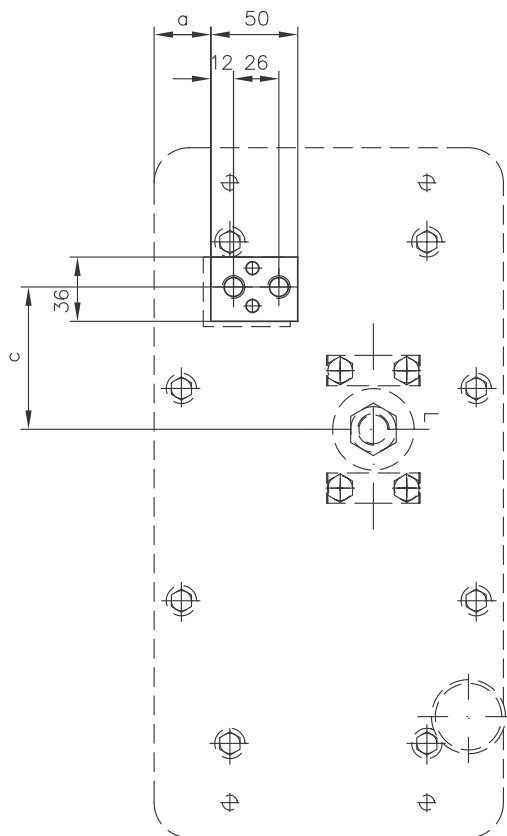
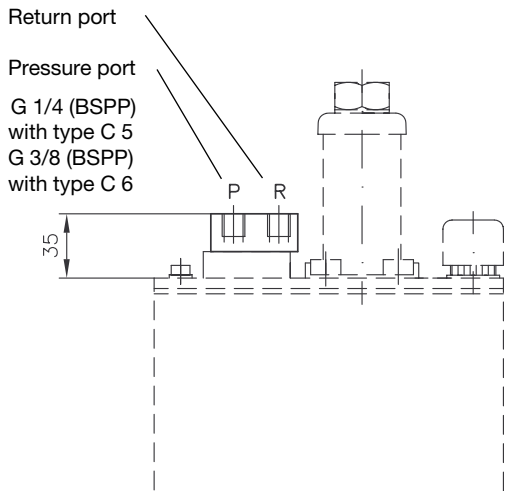

Version  
with pressure limiting valve

Example: **Type A 1/..to A 4/..** acc. to D 6905 A)

Type            B ... /...            (acc. to D 6905 B)  
                  AP 1(3)..        (acc. to D 6905 AP)  
                  AX 14(3)..        (acc. to D 6905 TÜV)

Similar mounting; For dimensional drawings, see the respective pamphlets!  
For versions with directly mounted directional valve banks, see sect. 3.3

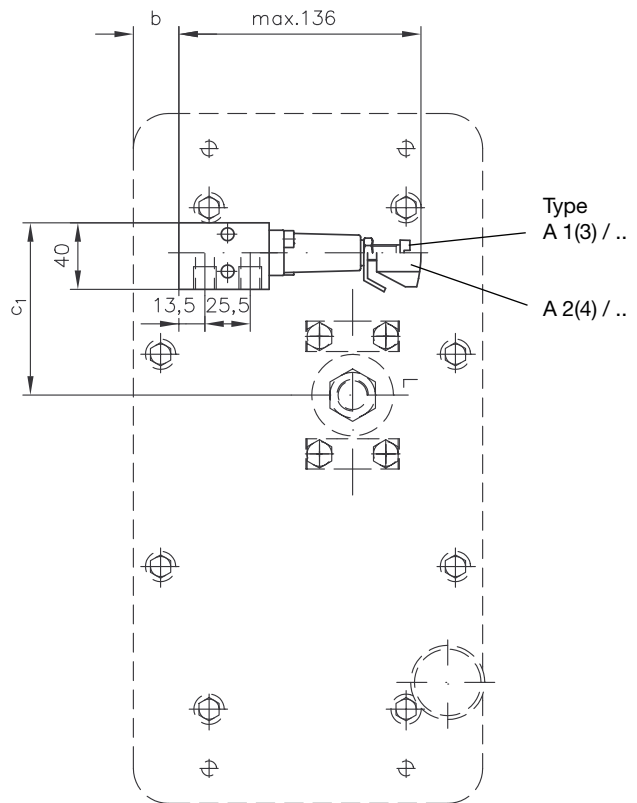
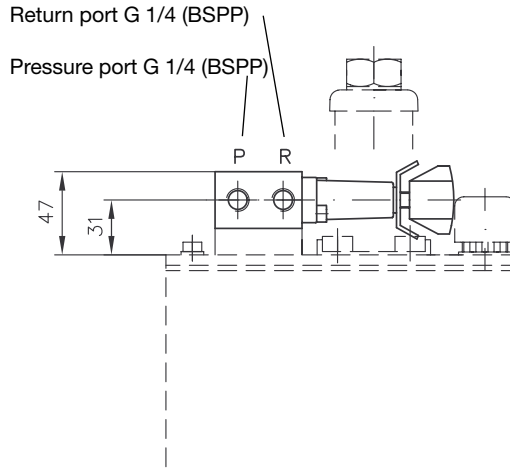

Type		a	b	c	c1
LP 80	B 4 (D 4)	31.5	27	77	95
	B 4 (D 4)				
LP 125	B 10 (D 10)	81.5	77	77	95
	B 25 (D 25)				
LP160	B 10 (D 10)	12.5	8	122.5	140.5
	B 25 (D 25)	32.5	18		

### 3.3 Versions with directly mounted directional valve banks (examples)

Examples: Type LP 125 - 16/B 10 - **VB 11 L P - HHH - 1**

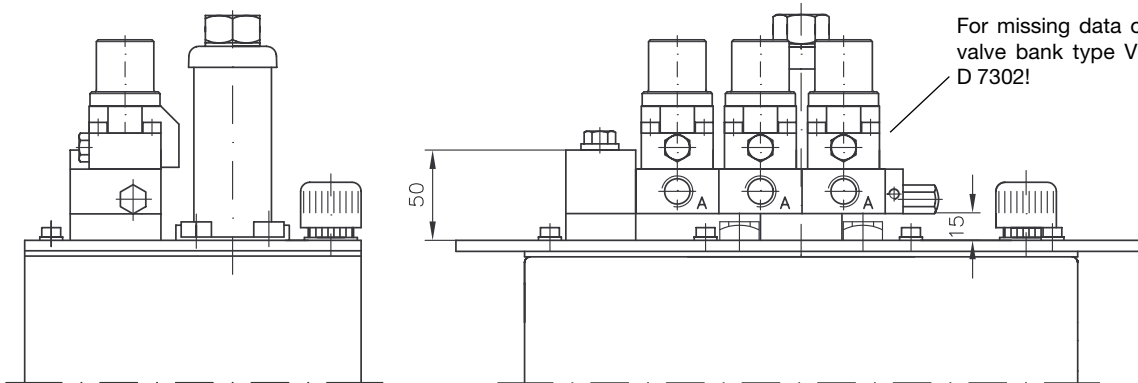

Ports A, M and R = G 1/4 acc. to DIN ISO 228/1 (BSPP)

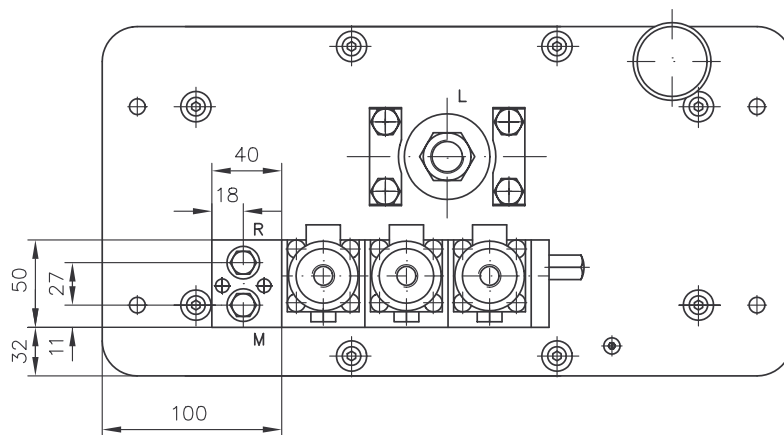

Example: Type LP 80 - 10/B 4 - **A 1/380 - BWH 1 S - NN - 1 - 1 - G24**

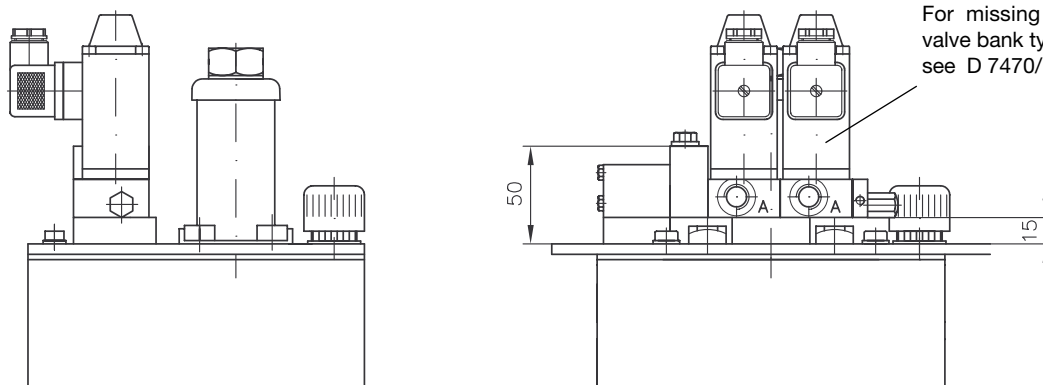

Ports A, M and R = G 1/4 acc. to DIN ISO 228/1 (BSPP)

