

Proportional pressure-limiting valve type PMV and PMVP

Product documentation



Operating pressure p_{\max} :

700 bar

Flow rate Q_{\max} :

120 lpm



OIL SOLUTIONS

PO Box 38
Strathfieldsaye, VIC, 3551
1800 OIL SOL
1800 645 765

sales@oilsolutions.com.au

www.oilsolutions.com.au

"For All Your Hydraulic Needs"





1800-OILSOL
1800-645765

<https://oilsolutions.com.au/>

sales@oilsolutions.com.au

© by HAWE Hydraulik SE.

The reproduction and distribution of this document as well as the use and communication of its contents to others without explicit authorisation is prohibited.

Offenders will be held liable for the payment of damages.

All rights reserved in the event of patent or utility model applications.

Brand names, product names and trademarks are not specifically indicated. In particular with regard to registered and protected names and trademarks, usage is subject to legal provisions.

HAWE Hydraulik respects these legal provisions in all cases.

Printing date / document generated on: 26.06.2018

Contents

1	Overview of proportional pressure-limiting valve type PMV and PMVP.....	4
2	Available versions, main data.....	5
2.1	Single valve, manifold mounting, pipe connection.....	5
3	Parameters.....	7
3.1	General and hydraulic.....	7
3.2	Electrical data.....	13
4	Dimensions.....	14
4.1	Single valve.....	14
5	Assembly, operation and maintenance recommendations.....	16
5.1	Intended use.....	16
5.2	Assembly information.....	16
5.2.1	Creating the mounting hole.....	16
5.3	Operating instructions.....	17
5.4	Maintenance information.....	17
6	Other information.....	18
6.1	Basic design.....	18
6.2	Circuit examples for type PMVS.....	19
6.3	Accessories, spare parts and separate components.....	20



1800-OILSOL
1800-645765

<https://oilsolutions.com.au/>

sales@oilsolutions.com.au

1 Overview of proportional pressure-limiting valve type PMV and PMVP

Proportional pressure-limiting valves are a type of pressure control valve. They remotely control the pressure in hydraulic systems continuously and electrically. The pressure-limiting valve type PMV is a directly actuated valve in a spring-loaded ball version. The pressure can be set to up to 700 bar. The pressure-limiting valve type PMV is available as a single valve for pipe connection or as a manifold mounting valve. The proportional pressure-limiting valve is particularly suitable for maximum pressure limitation in hydraulic systems.

Features and benefits:

- Operating pressures up to 700 bar
- Precise control

Intended applications:

- General hydraulics
- Test benches



Pipe connection type PMV

2 Available versions, main data

2.1 Single valve, manifold mounting, pipe connection

Circuit symbol:

PMV

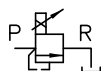

PMVS

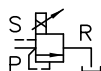

PMVP

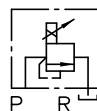

PMVPS

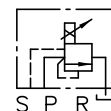

Order coding example:

PMV 63 - 41 - X 24

Solenoid voltage Table 3 Solenoid voltage

Proportional actuator Table 2 Proportional actuator

Basic type and size Table 1 Basic type and size

Table 1 Basic type and size

Main valve

Basic type and size	Port (BSPP)	Flow rate Q_{max} (lpm)
For pipe connection		
PMV 41	G 1/4	16
PMV 42	G 3/8	16
PMV 51	G 1/4	16
PMV 52	G 3/8	40
PMV 53	G 1/2	60
PMV 62	G 3/8	60
PMV 63	G 1/2	75
PMV 64	G 3/4	75
PMV 84	G 3/4	120
PMV 85	G 1	120
PMVS 41	G 1/4	16
PMVS 51		
For manifold mounting		
PMVP 4	--	16
PMVP 5	--	40
PMVP 6	--	75
PMVP 8	--	120
PMVP 45	--	16
PMVP 56	--	60
PMVP 65	--	60
PMVPS 4	--	16
PMVPS 8	--	120
PMVPS 45	--	16



1800-OILSOL
1800-645765

<https://oilsolutions.com.au/>

sales@oilsolutions.com.au

Table 2 Proportional actuator
Pipe connection

Coding	Proportionally controllable pressure range (bar) p_{\min} to p_{\max} *)											
	PMV										PMVS	
	41	42	51	52	53	62	63	64	84	85	41	51
- 41	5 to 180		5 to 110			5 to 80			5 to 45		(0) to 180	(0) to 110
- 42	5 to 290		5 to 180			5 to 130			5 to 70		(0) to 290	(0) to 180
- 43	5 to 440		5 to 270			5 to 190			5 to 110		(0) to 440	(0) to 270
- 44	5 to 700		5 to 450			5 to 320			5 to 180		(0) to 700	(0) to 450

Manifold mounting

Coding	Proportionally controllable pressure range (bar) p_{\min} to p_{\max} *)											
	PMVP						PMVPS					
	4	45	5	65	56	6	8	4	45	8		
- 41	5 to 180		5 to 110			5 to 80		5 to 45		(0) to 180	(0) to 110	(0) to 45
- 42	5 to 290		5 to 180			5 to 130		5 to 70		(0) to 290	(0) to 180	(0) to 70
- 43	5 to 440		5 to 270			5 to 190		5 to 110		(0) to 440	(0) to 270	(0) to 110
- 44	5 to 700		5 to 450			5 to 320		5 to 180		(0) to 700	(0) to 450	(0) to 180

*) Pressure value p_{\min} of below 5 bar can only be achieved under approx. (0.1 to 0.2) Q_{\max}

Table 3 Solenoid voltage

Coding	Electrical connection	Nominal voltage	Protection class (IEC 60529)
X 12	Industry standard, 11 mm contact gap (Coding G.. with line connector, coding L.. with line connector with LED)	12 V DC	IP 65
X 24		24 V DC	

Connection pattern

G .., X .., L ..

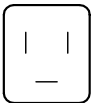

The specifications regarding the IP protection class apply for versions featuring a properly assembled line connector.

3 Parameters

3.1 General and hydraulic

Designation	Proportional pressure-limiting valve
Design	Directly controlled, ball seat
Model	Manifold mounting valve, valve for pipe installation
Material	Electrogalvanised
Installation position	As desired
Ports	P: Pump pressure, system pressure R, T: Reflux, tank S: Control port
Hydraulic fluid	Hydraulic oil: according to DIN 51 524 Part 1 to 3; ISO VG 10 to 68 according to DIN 51 519 Viscosity range: min. approx. 4; max. approx. 1500 mm ² /s Optimal operating range: approx. 10 to 500 mm ² /s Also suitable for biologically degradable pressure fluids type HEPG (polyalkylene glycol) and HEES (synthetic ester) at operating temperatures up to approx. +70°C.
Cleanliness level	ISO 4406 20/17/14...18/15/12
Temperatures	Ambient: approx. -40 ... +80°C, Fluid: -25 ... +80°C, Note the viscosity range! Permissible temperature during start: -40°C (observe start-viscosity!), as long as the service temperature is at least 20K higher for the following operation. Biologically degradable pressure fluids: Observe manufacturer's specifications. By consideration of the compatibility with seal material not over +70°C.

Pressure and flow rate

Operating pressure	P: p_{\max} according to pressure range R, T: $p_{\max R} \leq 20$ bar; see Δp -Q characteristics S: $p_{\max} = 700$ bar
Internal control oil consumption	Max. approx. 1.0 lpm



1800-OILSOL
1800-645765

<https://oilsolutions.com.au/>

sales@oilsolutions.com.au

Δp -Q characteristics (reference values)

The lowest usable control point depends on the flow rate and can be estimated from the Δp_0 -Q characteristics for $I = 0$ A.

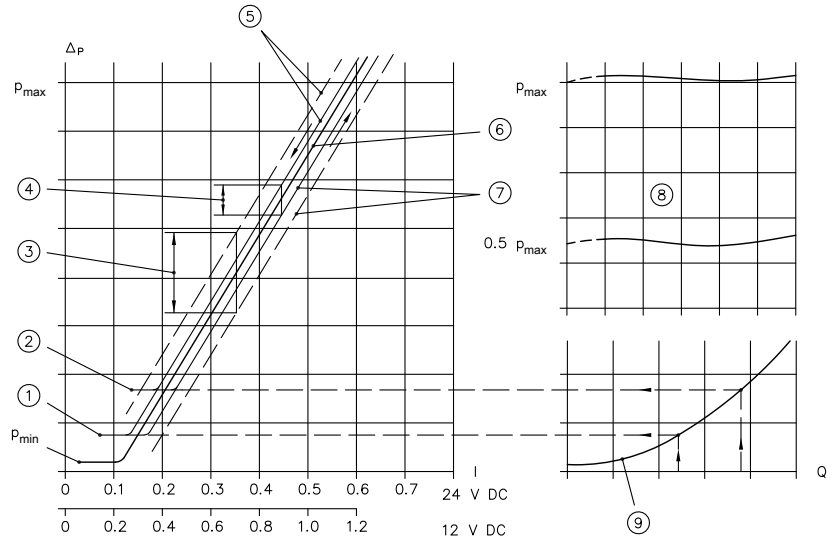

Q flow rate (lpm); I control current (A); Δp controlled pressure (bar)

- 1 Start of control for low flow rate
- 2 Start of control for high flow rate
- 3 Hysteresis without dither: approx. 30 bar (smooth supply)
- 4 Hysteresis with dither: approx. 10 bar
- 5 Control current, falling
- 6 Centre lines according to diagram, page 5
- 7 Control current, rising
- 8 Δp -Q characteristics for selected control position largely independent of flow rate
- 9 Flow resistance Δp_0 at $I = 0$ A (inherent resistance)

Characteristics

Oil viscosity approx. 60 mm²/s

Δp -Q characteristics (reference values)

The pressure is largely independent of the flow rate.

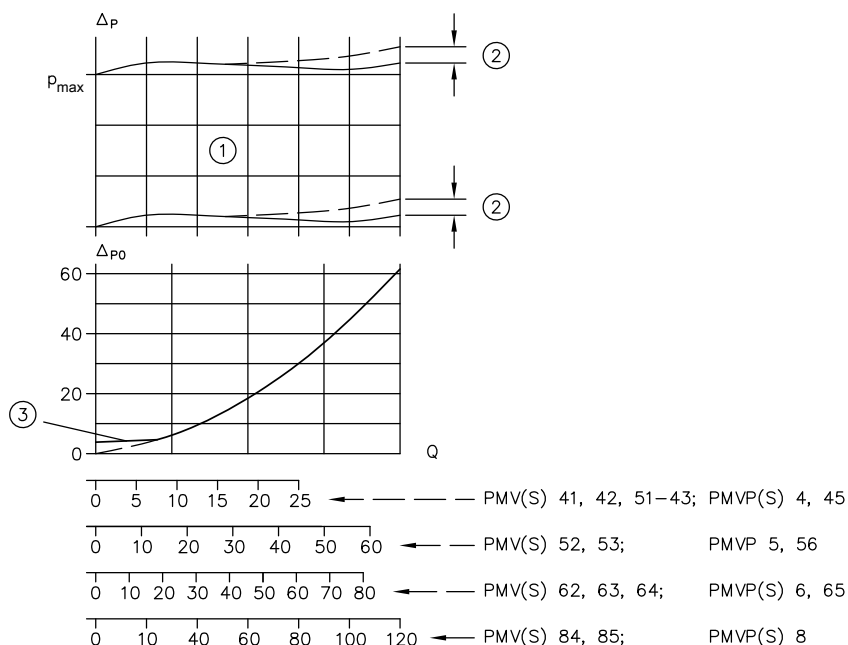

Q flow rate (lpm); Δp_0 flow resistance (bar) at $I = 0$ A; Δp controlled pressure (bar) according to the control current I (A)

- 1 Δp -Q characteristics for selected control position largely independent of flow rate
- 2 In the case of return pressure > 3 bar $\Delta p = + 6$ to 15 bar at Q_{max}
- 3 Minimum pre-load at the adjusting screw Δ approx. 3 to 5 bar



1800-OILSOL
1800-645765

<https://oilsolutions.com.au/>

sales@oilsolutions.com.au

Oil viscosity approx. 60 mm²/s

Δp -Q characteristics (reference values)

PMV(S) 41, PMV(S) 42, PMVP(S) 4

..-41 ..-42 ..-43 ..-44

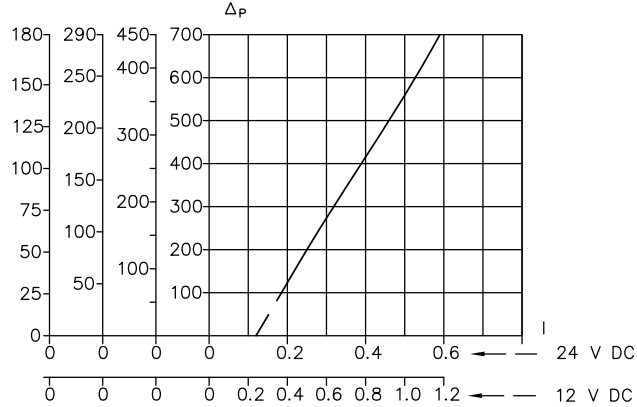

I control current (A); Δp controlled pressure (bar)

Type	Average pressure change (bar/0.1 A)
------	-------------------------------------

PMV..-41	Approx. 38
PMV..-42	Approx. 62
PMV..-43	Approx. 96
PMV..-44	Approx. 150

PMV(S) 51, PMV(S) 52, PMV(S) 53
PMVP(S) 45, PMVP(S) 5, PMVP(S) 65

..-41 ..-42 ..-43 ..-44

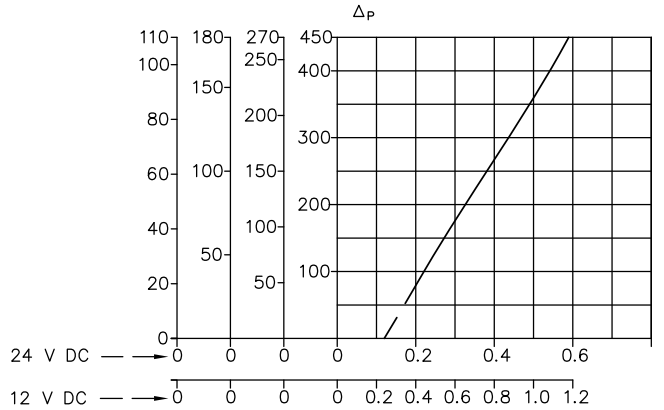

I control current (A); Δp controlled pressure (bar)

Type	Average pressure change (bar/0.1 A)
------	-------------------------------------

PMV..-41	Approx. 23
PMV..-42	Approx. 38
PMV..-43	Approx. 58
PMV..-44	Approx. 94

Characteristics

Oil viscosity approx. 60 mm²/s

Δp -Q characteristics (reference values)

**PMV 62, PMV 63, PMV 64
PMVP 56, PMVP 6**

..-41 ..-42 ..-43 ..-44

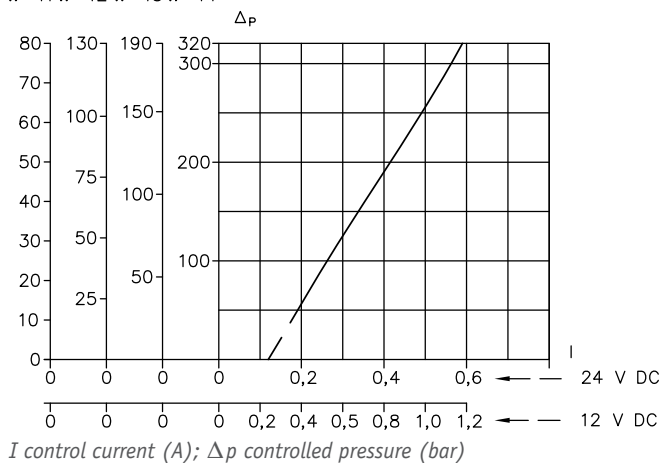

Type	Average pressure change (bar/0.1 A)
PMV..-41	Approx. 17
PMV..-42	Approx. 28
PMV..-43	Approx. 40.5
PMV..-44	Approx. 68

**PMV 84, PMV 85
PMVP 8**

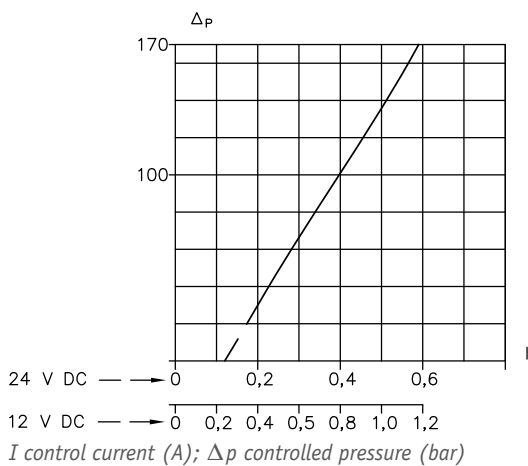

Type	Average pressure change (bar/0.1 A)
PMV..-41	Approx. 95
PMV..-42	Approx. 15
PMV..-43	Approx. 28
PMV..-44	Approx. 38



1800-OILSOL
1800-645765

<https://oilsolutions.com.au/>

sales@oilsolutions.com.au

Weight

Type

PMV 41, PMV 42, PMV 51, PMV 52	= 1.2 kg
PMV 53	= 1.3 kg
PMV 62	= 1.2 kg
PMV 63	= 1.3 kg
PMV 64, PMV 84	= 1.5 kg
PMV 85	= 1.9 kg
PMVS 41, PMVS 51	= 1.2 kg
PMVP 4, PMVP 45	= 1.1 kg
PMVP 5, PMVP 56	= 1.2 kg
PMVP 6, PMVP 65	= 1.3 kg
PMVP 8	= 1.7 kg
PMVPS 4, PMVPS 45	= 1.1 kg
PMVPS 8	= 1.7 kg



3.2 Electrical data

Cooling power P_{20}	12 V DC	24 V DC
	24 W	24 W
Nominal power P_N	9.5 W	9.5 W
Current, cold I_{20}	2 A	1 A
Nominal current I_N	1.26 A	0.63 A
Coil resistance $R_{20} \pm 5\%$	6 Ω	24 Ω
Relative duty cycle (ED) 100% ED	Reference temperature $\vartheta_{11} = 50^\circ\text{C}$	
Protection class	see Chapter 2.1, "Single valve, manifold mounting, pipe connection" , Table 3	
Electrical connection	Industry standard (11 mm contact gap)	
Required dither frequency	60 to 150 Hz	
Dither amplitude	20 to 40% of I_{20}	

Reference value for the cold resistance

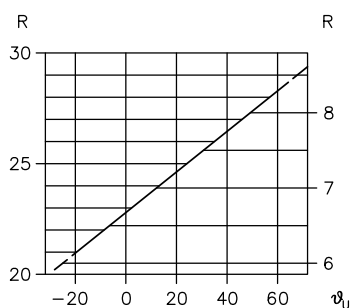

ϑ_0 ambient temperature ($^\circ\text{C}$); R cold resistance (Ω) solenoid 24 V DC; R cold resistance (Ω) solenoid 12 V DC



1800-OILSOL
1800-645765

<https://oilsolutions.com.au/>

sales@oilsolutions.com.au

4 Dimensions

All dimensions in mm, subject to change.

4.1 Single valve

PMV, PMVS

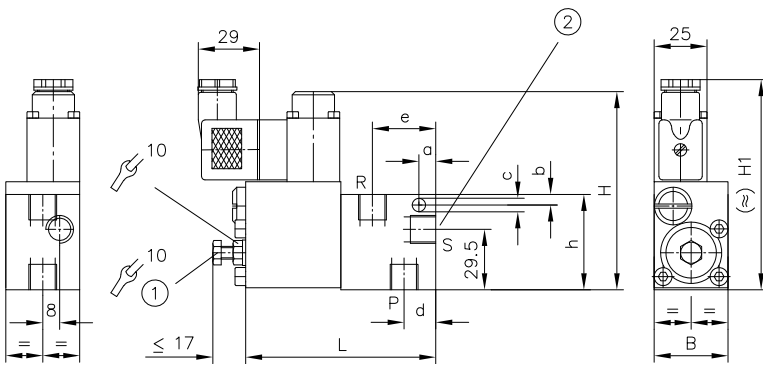

- 1 Adjusting screw p_{min}
- 2 Port S (G 1/4) for type PMVS ... only

Type	Ports (BSPP) P, R	B	H	H1	L	a	b	c	d	e	h	h1
PMV 41 PMV 51 PMVS 41 PMVS 51	G 1/4	35	94	99.5	90.1	8	8	6.4	15	30	45	71
PMV 42 PMV 52 PMV 62	G 3/8	35	96	101.5	95.1	10	10	6.4	17.5	35	45	73.5
PMV 53 PMV 63	G 1/2	35	97	102.5	95.1	10	8	6.4	15	31.5	50	74.5
PMV 64 PMV 84	G 3/4	40	101	106.5	105.1	15	15	8.5	17.5	40	60	78.5
PMV 85	G 1	45	106	111.5	115.1	15	15	8.5	25	44.5	70	88.5

PMVP, PMVPS

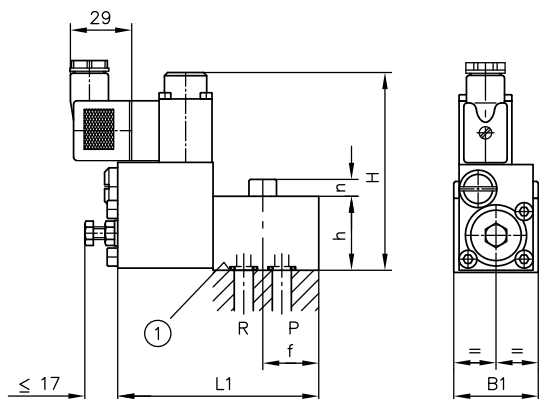

1 Sealing of ports P and R with O-rings

Base plate hole pattern

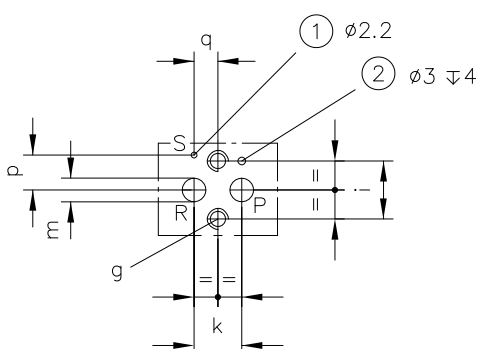

- 1 Port S for type PMVPS ... only
- 2 Mounting hole for assembly centring pin

Type	B1	L1	H	f	g	h	i	k	m	n	p ±0.1	q +0.1	O-ring NBR 90 Sh
PMVP 4 PMVP 45 PMVPS 4 PMVPS 45	35	90.1	94	21	M8	35	22	14	6	8	13.25	9	8x2 (2.57x1.78)
PMVP 5 PMVP 56	40	95.1	94	26.5	M8	35	27	18	9	8	--	--	10x2
PMVP 6 PMVP 65	50	95.1	94	25	M10	35	34	22	12	10	--	--	13.95x2.62
PMVP 8 PMVPS 8	60	105.1	96	33	M12	40	40	26	16	12	20	13	18.75x2.62 (2.57x1.78)



1800-OILSOL
1800-645765

<https://oilsolutions.com.au/>

sales@oilsolutions.com.au

5.1 Intended use

This valve is intended exclusively for hydraulic applications (fluid technology).

The user must observe the safety measures and warnings in this documentation.

Essential requirements for the product to function correctly and safely:

- All information in this documentation must be observed. This applies in particular to all safety measures and warnings.
- The product must only be assembled and put into operation by qualified personnel.
- The product must only be operated within the specified technical parameters. The technical parameters are described in detail in this documentation.
- The operating and maintenance manual of the components, assemblies and the specific complete system must also always be observed.

If the product can no longer be operated safely:

1. Remove the product from operation and mark it accordingly.
- ✓ It is then not permitted to continue using or operating the product.

5.2 Assembly information

The product must only be installed in the complete system with standard and compliant connection components (fittings, hoses, pipes, fixtures, etc.).

Reaction forces and reaction torques must not influence the valve.

The hydraulic power pack must be shut down correctly prior to dismantling; this applies in particular to power packs with hydraulic accumulators.



Danger

Risk to life caused by sudden movement of the hydraulic drives when dismantled incorrectly!

Risk of serious injury or death.

- Depressurise the hydraulic system.
- Perform safety measures in preparation for maintenance.

5.2.1 Creating the mounting hole

See description in [Chapter 4, "Dimensions"](#).

5.3 Operating instructions

Product configuration and setting the pressure and flow rate

The statements and technical parameters in this documentation must be strictly observed.
The instructions for the complete technical system must also always be followed.

Note

- Read the documentation carefully before usage.
- The documentation must be accessible to the operating and maintenance staff at all times.
- Keep documentation up to date after every addition or update.

Caution

Risk of injury on overloading components due to incorrect pressure settings!

Risk of minor injury.

- Always monitor the pressure gauge when setting and changing the pressure.

Purity and filtering of the hydraulic fluid

Fine contamination can significantly impair the function of the hydraulic component. Contamination can cause irreparable damage.

Examples of fine contamination include:

- Metal chips
- Rubber particles from hoses and seals
- Dirt due to assembly and maintenance
- Mechanical debris
- Chemical ageing of the hydraulic fluid

Note

Fresh hydraulic fluid from the drum does not always have the highest degree of purity. Under some circumstances the fresh hydraulic fluid must be filtered before use.

Pay attention to the cleanliness level of the hydraulic fluid in order to maintain faultless operation.

(Also see cleanliness level in [Chapter 3, "Parameters".](#))

(also see cleanliness level in

5.4 Maintenance information

This product is largely maintenance-free.

Conduct a visual inspection at regular intervals, but at least once per year, to check if the hydraulic connections are damaged. If external leakages are found, shut down and repair the system.

Clean the device surface of dust deposits and dirt at regular intervals, but at least once per year.



1800-OILSOL
1800-645765

<https://oilsolutions.com.au/>

sales@oilsolutions.com.au

6 Other information

6.1 Basic design

The proportional pressure-limiting valves type NPMVP are directly actuated devices consisting of the main valve (ball seated valve **1**, spring **2** and set piston **3** and the flange-mounted proportional control part (proportional pressure-reducing valve **4** and pressure reducing valve preliminary stage **5**).

The system pressure tapped in the main valve, port P, is reduced in the preliminary stage **3** to a low, constant inlet pressure for the control valve **4**. In the control valve **4**, this pressure is converted into the electrical-proportional pilot pressure and directed to the set piston **3**, which loads the valve **1** accordingly via the spring **2**. This results in the current system pressure at inlet P. The various pressure ranges are determined by the size of the proportional pressure-reducing valve **4** and main valve.

Adjusting screw **6** for pre-loading the spring **2**. As a result, the lower threshold value p_{\min} of the proportionally controllable pressure range of approx. 3 bar can be raised. This means that, when below the corresponding control current, this increased pressure value remains constant, even in the case of a reduction to 0 A, apart from the flow-related deviation ([Chapter 3.1, "General and hydraulic"](#), see characteristics).

A minimum pressure of 3 bar or more is required for proper functioning of the proportional pressure-reducing valve type NPMVP **4**.

Detailed circuit symbols

PMV, PMVP

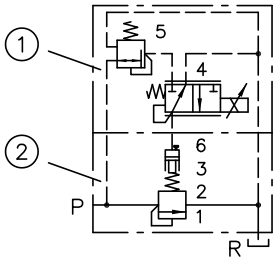

- 1 Proportional control valve
- 2 Main valve

PMVS, PMVPS

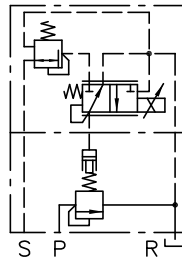

6.2 Circuit examples for type PMVS

Example 1:

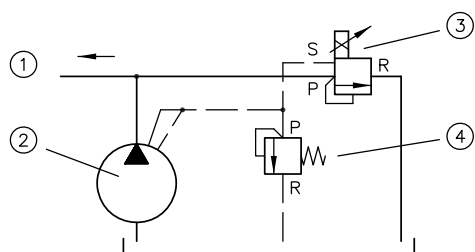

- 1 Directional valve, consumer
- 2 e.g. R 10.1 - 0.8 - 0.8/M 5.5 according to [D 6010 S](#)
- 3 PMVS 51-43/24
(0) to 270 bar
- 4 MV 41F - 20 bar according to [D 7000/1](#)

In the case of R pumps according to [D 6010 S](#), it is advisable to choose and combine two single ports for the control oil.

The pump pulsation will then be lower.

Otherwise, the pulsation could be damped with a small accumulator and downstream throttle.

Example 2:

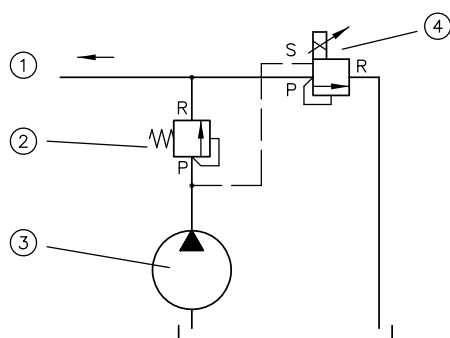

- 1 Directional valve, consumer
- 2 MVS 41F - 20 according to [D 7000/1](#)
 $\Delta p = 20$ bar
- 3 e.g. R 6.1/M 11 according to [D 6010 H](#)
- 4 PMVS 41-44/24
(0) to 700 bar

6.3 Accessories, spare parts and separate components

Description	Type	Order no.
Test block	PMVP 8, PMVPS 8	3406 872 000

Line connector

Description	Type	Material number
No additional function	MSD 6-209	6236 5004-00
With LED	SVS 3129720	6217 8027-00
Adapter for DIN EN 175 301-803 A	--	6217 0238-00



1800-OILSOL
1800-645765

<https://oilsolutions.com.au/>

sales@oilsolutions.com.au

Further information

Additional versions

- Proportional pressure-limiting valve type NPMVP: D 7485 N
- Proportional pressure-limiting valve type PDV and PDM: D 7486
- Connection blocks type A for hydraulic power packs: D 6905 A/1
- Proportional amplifier type EV1M3: D 7831/2
- Proportional amplifier type EV1D: D 7831 D
- Proportional amplifier type EV2S: D 7818/1



1800-OILSOL
1800-645765

<https://oilsolutions.com.au/>

sales@oilsolutions.com.au