

# Proportional pressure valves, types PDV and PDM

piloted

Pressure  $p_{max}$  = 350 bar  
 Flow  $Q_{max}$  = 120 lpm

## 1. General

Proportional pressure valves are used for continuous electrical remote control of the pressure in hydraulic systems. Depending on the type, these devices can be used as:

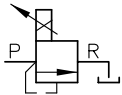

- **Pressure limiting valves**  
 The preselected pressure in each case will not be exceeded in the hydraulic circuit, connection side P.

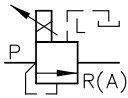

- **Sequence valves**  
 When a particular preselected pressure is reached, the valve opens the passage to a circuit, at connected after the valve, at connection side R(A), and connects it without any pressure differential (inherent resistance only) for a further pressure rise, together with the hydraulic circuit at the inlet side P.

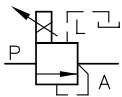

- **Pressure reducing valves**  
 The output pressure, at connection side A, to a following circuit is kept constant at the particular value preselected in each case (secondary pressure), regardless of a changing higher pressure at the inlet side P (primary pressure).

## 2. Mounting and function

Proportional pressure valves are indirectly-actuated devices which consist of a main valve and a proportional pilot valve flanged onto it.

The main valve essentially contains the piston ①, which runs in a sleeve mounted in the housing in stressfree bearings. Depending on the type concerned, the piston ① in its working position (throttle setting) exerts an opening or closing effect on the main passage P→R (A). Each particular working position is attained by means of a pressure differential at the control nozzle ③, which displaces the piston ① against the resetting spring ② until a force balance pertains.

The most important parts of the pilot valve are the pilot pressure limiting valve ④ and the proportional pressure limiting valve ⑤, which loads the setting piston ⑥ with its electrically-proportionally controlled output pressure and thus determines the pressure setting of the valve ④. This pressure setting, as a counterpressure behind the nozzle ③, serves to balance out the overall pressure differential between the connections P and R or P and L. The proportion between them is the value of the control oil flow (approx. 0.6...0.8 lpm), which flows via ③ and ④, and which produces the pressure drop in ③, required for the working position of the piston ①. The purpose of the pressure control valve primary stage ⑦ is to reduce the inlet pressure for the proportional pressure control valve ④ to a constant low value which is capable of sensitive adjustment.

Accordingly, the electric-proportional setting of the control pressure for ④ also produces the proportionally consecutive operating position of the main valve ①.

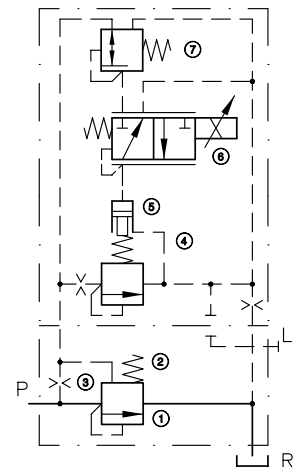

OIL SOLUTIONS

PO Box 38  
 Strathfieldsaye, VIC, 3551  
 1800 OIL SOL  
 1800 645 765

[sales@oilsolutions.com.au](mailto:sales@oilsolutions.com.au)

[www.oilsolutions.com.au](http://www.oilsolutions.com.au)

"For All Your Hydraulic Needs"

### 3. Types available, main data

Order examples:

**PDM 4P H - G 12**  
**PDV 3G M - G 24 - WN 1F - G 24**

Solenoid voltage of the 2/2-way directional seated valve acc. to table 4

**Table 1:** Basic type

Coding	Version	Control oil line
<b>PDV</b>	Pressure limiting valve. Permissible pressure at R ≤ 20 bar (added to desired pressure setting)	Internally via port R
<b>PDVE</b>	Pressure limiting valve. Counterpressure at R has no influence on pre-selected pressure setting value	Externally via port L (pressureless to tank)
	Sequence valve	
<b>PDM</b>	Pressure reducing valve Permiss. press. at P ≤ 400 bar	

**Table 4:** Additional 2/2-way solenoid valve only with PVD

Coding	Idle circulation	Circulation pressure	Valve data
<b>WN 1D</b>	energized	app. 5 bar see also sect. 4.1	see D 7470 A/1
<b>WN 1F</b>	de-energized		

Note:  
For arbitrary pump circulation switching, regardless of the momentary response of the proportional solenoid.

**Table 2:** Size, connection mode

Size	Coding	3	4	5
	Flow Q <sub>max</sub> (lpm)	40	80	120
Connection mode	Direct pipe connection	<b>G</b>	G 1/2 ISO 228/1 (BSPP)	G 1
	Manifold mounting	<b>P</b>	see directional drawing in sect. 5.2	

**Table 3:** Proportional pilot valve

Coding	Pressure range P <sub>min</sub> ... P <sub>max</sub> (bar)	Operat. voltage	
		<b>G 12</b>	<b>G 24</b>
<b>N</b>	15 ... 130	12V DC	24V DC
<b>M</b>	15 ... 200	For detailed data, see sect. 4.2	
<b>H</b>	15 ... 350		

### 4. Additional characteristic data

#### 4.1 General and hydraulic

Nomenclature, design	Piloted prop. pressure valves, piston type
Line connection	Threads to ISO 228/1, pipe fittings with male thread, shape B, DIN 3852 Sheet 2, or via manifold depending on type
Installation position	As desired
Flow direction	From P to R(A) at all types (working direction). With PDM, return flow from A → P is possible up to Δp ≈ 33 bar, see Δp-Q-curve. In the event of return flows, the piston would block the passage, and in such cases a bypass check valve must be installed
Pressure fluid	Hydraulic oil conf. DIN 51524 part 1 to 3: ISO VG 10 to 68 conf. DIN 51519 Viscosity limits: min. approx. 4, max. approx. 1500 mm <sup>2</sup> /s Optimal operation: approx. 10 ... 500 mm <sup>2</sup> /s Also suitable for biological degradable pressure fluids types HEPG (Polyalkylenglycol) and HEES (Synth. Ester) at service temperatures up to approx. +70 °C
Temperature range	Ambient: approx. -40 ... +80 °C Fluid: -25 ... +80°C, Note the viscosity range Permissible temperature during start: -40°C (observe start-viscosity!), as long as the service temperature is at least 20K (Kelvin) higher for the following operation Biological degradable pressure fluids: Observe manufacturer's specifications. Considering the compatibility with seal material not over +70 °C. <b>Attention:</b> Observe the restrictions regarding the permissible operation duration of the actuation solenoids

Mass (weight) approx. kg	Size	PDV..G 1)	PDV..P 1)
		PDVE..G	PDVE..P
		PDM..G	PDM..P
	3	1.8 (2.4)	---
	4	2.2 (2.8)	2.7 (3.3)
	5	2.7 (3.3)	3.2 (3.8)

1) Figures in brackets apply, when a 2/2-way directional valve type WN 1F(D) is mounted

$\Delta p$ -Q-curves

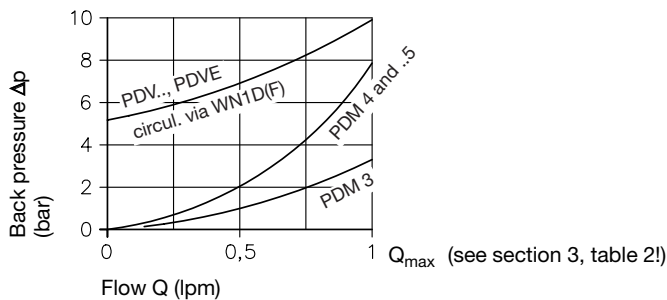

Oil viscosity during measurement 60 mm<sup>2</sup>/s

Control oil flow

The control oil flow discharged externally via L is approx. 0.6...0.8 lpm for type PDVE... (pressure limiting valve) and at type PDM... (pressure reducing valve).  
When type PDVE... is employed as sequence valve, this flow depends on the difference between the pressure level on the inlet side P and the preselected response pressure (outlet A), and can be up to approx. 6 lpm.

4.2 Electrical data

Proportional solenoid acc. to table 3, in sect. 3

For data of the 2/2-way directional seated valve type WN 1 (acc. to table 4, sect. 3), see D 7470 A/1 !

Rated voltage $U_N$		12V DC	24V DC
Resistance, cold $R_{20} \pm 5\%$		7.2 $\Omega$	24.6 $\Omega$
Current cold $I_{20}$		1.7 A	1.0 A
Lim. current $I_G (I_{lim})$		1.2 A	0.68 A
Power, cold $P_{20}$		20.1 W	23.5 W
Rated power $P_N$		9.8 W	11.4 W
Inductivity L		0.09 H	0.3 H
Relative duty cycle	100% ED (ref. temp. $\vartheta_{11} = 50^\circ\text{C}$ )		
Electrical connection	DIN 43650		
Protection mode	IP 67 acc. to IEC 60529		
Required dither frequency	50 ... 150 Hz		
Dither amplitude (peak-peak)	20 ... 40% of $I_G$		

$\Delta p - I_{contr}$  - curve

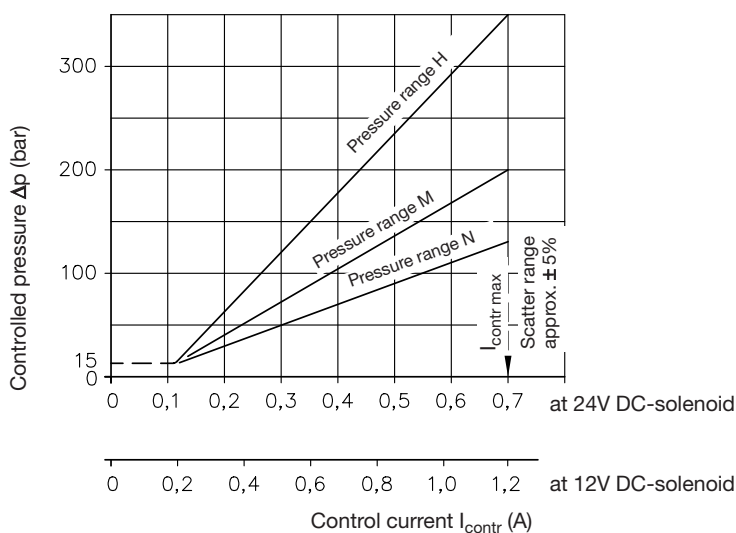

1800-OILSOL  
1800-645765

<https://oilsolutions.com.au/>

sales@oilsolutions.com.au

## 5. Unit dimensions

All dimensions in mm, subject to change without notice !

### 5.1 Versions for direct pipe connection

Type PDV(E)..G and PDM..G

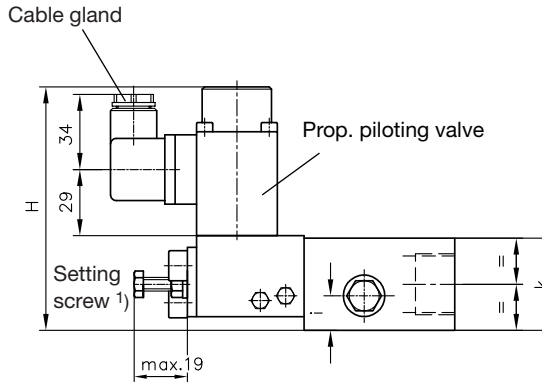

Type PDV..G - WN1F(D)

Directly mounted 2/2-way directional valve type WN1F(D) acc. to D 7470 A/1

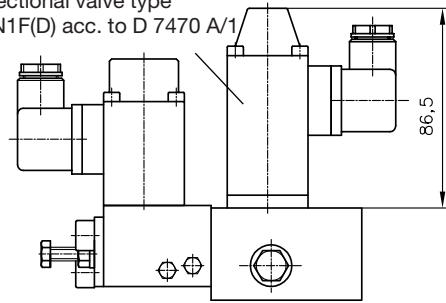

For missing data see below !

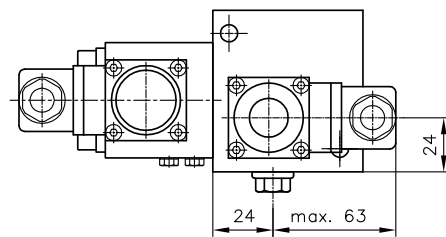
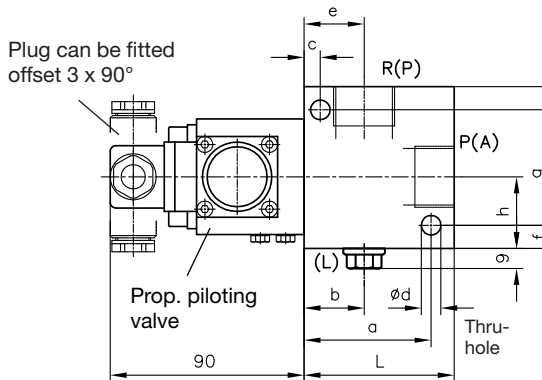

Size	L	B	H	a	b	c	d	e	f	g	h	i	k	Ports ISO 228/1 (BSPP)		
														PDV(E) P and R	PDM (P), (A)	(L)
3	60	65	100	51.5	27	8.5	Ø8.5	25	8.5	49	32	11	30	G 1/2	G 1/2	G 1/4
4	65	71	99.5	55	26	7	Ø8.5	26.5	11	50	32	15	40	G 3/4	G 3/4	G 1/4
5	80	73	104.5	68	22.5	68	Ø10.5	39	9	52	33	25	50	G 1	G 1	G 1/4

### 5.2 Version for manifold mounting

Type PDV(E)..P and PDM..P

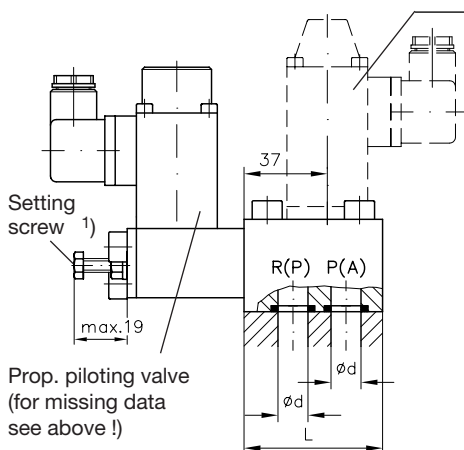

Optional, directly mounted 2/2-way directional valve type WN1F(D) acc. to D 7470 A/1 e.g. PDV 4P H-G 24 - WN 1F-G 24

1) This setting screw can be used to raise the minimum pressure  $p_{min}$  (table 3, section 3) above 15 bar. This preselected pressure value for  $p_{min}$  cannot then be undercut, even if the control current is stepped down even further. Loosen the lock-nut A/F 10 (Seal-Lock nut) sufficiently before adjustment is carried out, in order to prevent the sealing ring, which is vulcanized in place, from being damaged by the thread.

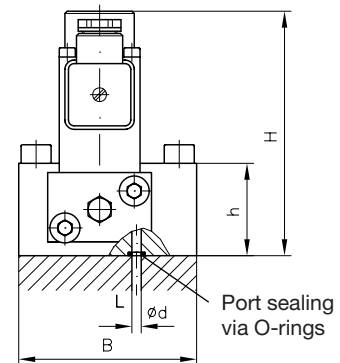

Hole pattern of the manifold (view from top)

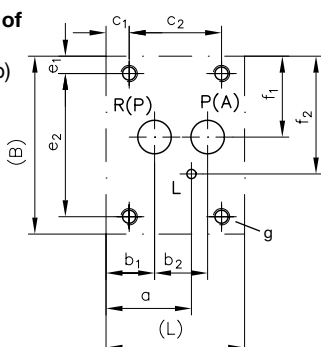

Size	L	B	H	a	b1	b2	c1	c2	e1	e2	f1	f2	h
4	60	78	99.5	37	21	23	10	40	7.5	62	35	51	40
5	88	81	104.5	51	36	30	26	46	8.5	63	38	57	50

Size	g	Ports Ød			O-ring NBR 90 Sh	
		PDV(E).. P and R	PDM.. (P), (A)	(L)	P(R), P(A)	(L)
4	M8, 10 deep	13	13	4	15.55x2.62	4.47x1.78
5	M10, 10 deep	17	17	4	20.29x2.62	4.47x1.78