

# 2/2-, 3/2-, and 4/3-way seated valves type NBVP 16 with industrial standard connection pattern Cetop 3 conforming DIN 24 340-A6

for any flow direction, zero leakage

Pressure  $p_{max} = 400$  bar  
Flow  $Q_{max} = 20$  lpm

|                                      |  |
|--------------------------------------|--|
| Additional valves with same function |  |
| Type BVG 1 and BVP 1                 | see D 7765 ( $Q_{max} = 20$ lpm, $p_{max} = 400$ bar)                  |
| Type BVG 3 and BVP 3                 | see D 7400 ( $Q_{max} = 60$ lpm, $p_{max} = 315$ bar)                  |
| Type BVE                             | see D 7921 ( $Q_{max} = 70$ lpm, $p_{max} = 400$ bar, cartridge valve) |
| Valve bank type BA                   | see D 7788   |
| Intermediate plates type NZP         | see D 7788 Z   |

## 1. General, brief description

The 2/2-, 3/2- and 4/3-way directional seated valves type NBVP 16 are cone seated valves and available with solenoid, hydraulic, pneumatic, or manual actuation. All ports of the 2/2- and 3/2-way directional valves are pressure resistant due to the internal pressure compensation.

Valves featuring a spring return will return automatically into their idle position when not activated. The detented version will achieve its idle or working position after a brief impulse at the opposing solenoid.

The 2/2- and 3/2-way directional valves are available with switching position monitoring and may be optionally equipped with directly mounted pressure switches.

4/2- and 4/3-way valves and valves with switching position monitoring may be optionally equipped with pressure switches or pressure gauges, which can be directly mounted via the pick-up ports (G 1/8 (BSPP)) connected to the consumer ports A and B.

### • Basic version



Example:

Type NBVP 16 R/2-G 24

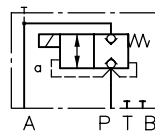

Type NBVP 16 Y/2-WG 230

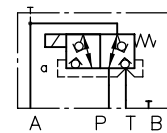

Type NBVP 16 G-GM 24

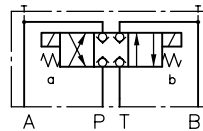

Type NBVP 16 D-WGM 230

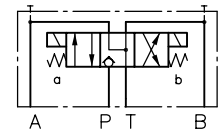

### • Additional elements for pump-, consumer- and return port

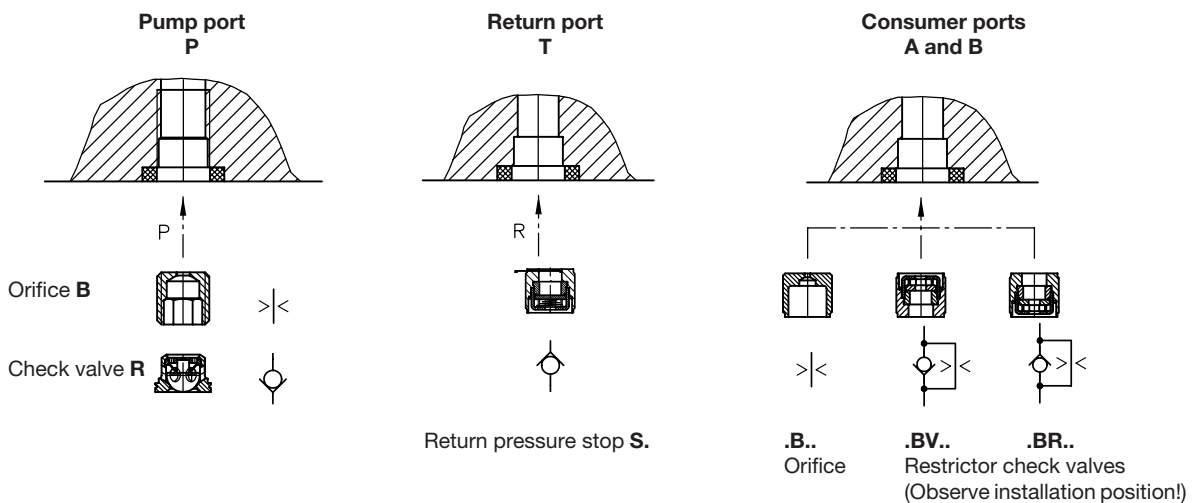

1800-OILSOL  
1800-645765

<https://oilsolutions.com.au/>

[sales@oilsolutions.com.au](mailto:sales@oilsolutions.com.au)



HAWE HYDRAULIK SE  
STREITFELDSTR. 25 • 81673 MÜNCHEN

**D 7765 N**  
Seated valves type NBVP 16

## 2. Available versions

### 2.1 Type coding, main data

Order examples:

**NBVP 16 S/B 0,8 /2 - WG 110** ①  
**NBVP 16 G/B 0,8 R/ABR2,0 BBR1,5 /A3 B9/400/S- GM 24 - 3/8** ②

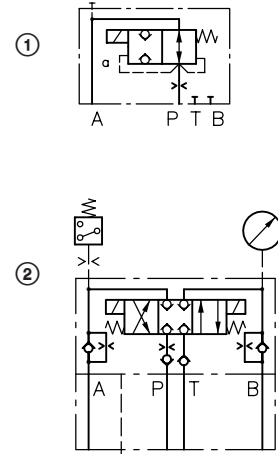
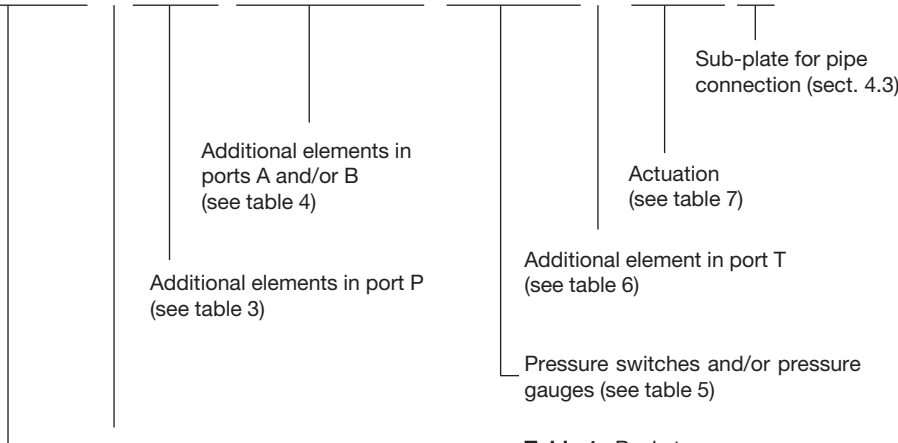
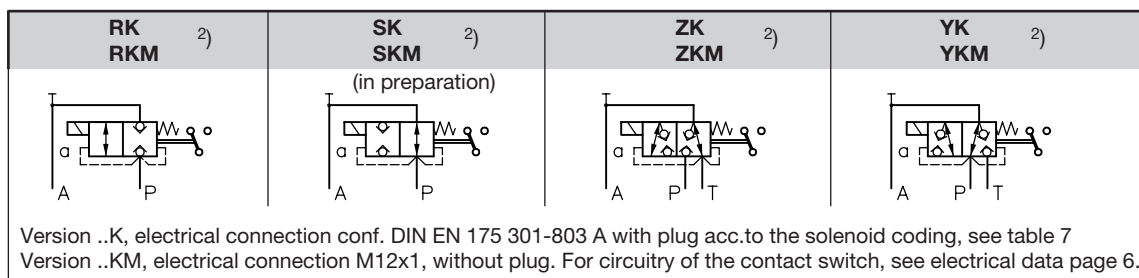
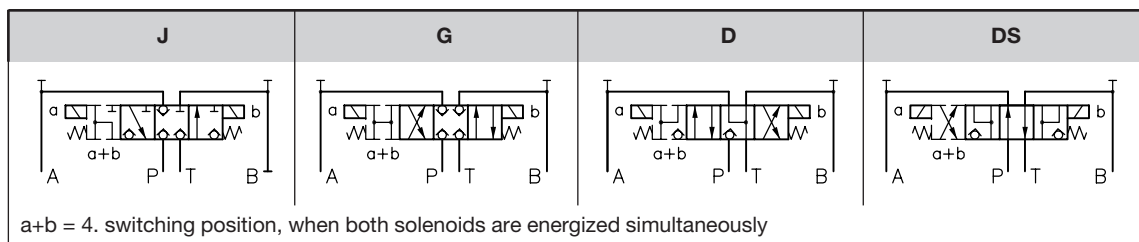
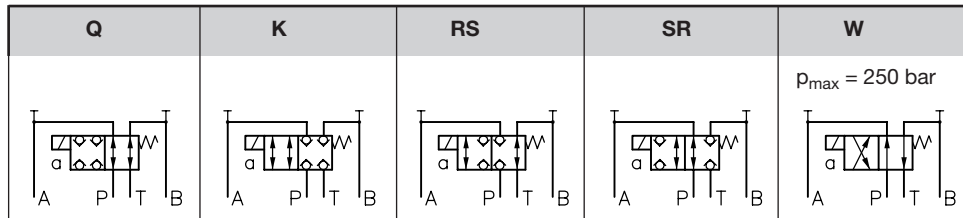
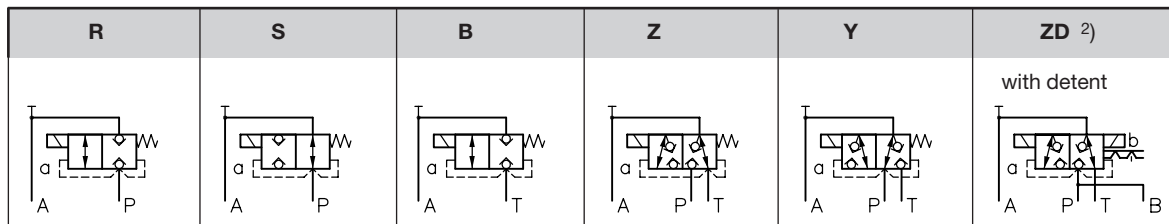

**Table 1:** Basic type

| Coding         | Description                                      | Flow Q <sub>max</sub> (lpm) | Pressure p <sub>max</sub> (bar) |
|----------------|--|-----------------------------|---------------------------------|
| <b>NBVP 16</b> | featuring a hole pattern conforming DIN 24340-A6 | 20                          | 400 / 250 1)                    |

**Table 2:** Symbols



(All valves are illustrated with solenoid actuation, for symbols with other actuations, see table 7)





1) 250 bar with solenoid actuation coding GM..., WGM.. acc. to table 7

2) Coding G, WG only with solenoid actuation

**Table 3:** Additional elements in port P <sup>5)</sup>

| Additional element (also in combination)  | Coding <sup>3)</sup> | ∅ (mm) |
|---|----------------------|--------|
| Orifice      | <b>B 0,4</b>         | 0,4    |
|   | <b>B 0,5</b>         | 0,5    |
|   | <b>B 0,6</b>         | 0,6    |
|   | <b>B 0,7</b>         | 0,7    |
|   | <b>B 0,8</b>         | 0,8    |
|   | <b>B 0,9</b>         | 0,9    |
|   | <b>B 1,0</b>         | 1,0    |
|   | <b>B 1,1</b>         | 1,1    |
|   | <b>B 1,2</b>         | 1,2    |
|   | <b>B 1,4</b>         | 1,4    |
|   | <b>B 1,5</b>         | 1,5    |
|   | <b>B 1,8</b>         | 1,8    |
|   | <b>B 2,0</b>         | 2,0    |
|   | <b>B 2,4</b>         | 2,4    |
|   | <b>B 2,5</b>         | 2,5    |
| <b>B 3,0</b>  | 3,0                  |        |
| <b>B 3,5</b>  | 3,5                  |        |
| <b>B 4,0</b>  | 4,0                  |        |
| Check valve  | <b>R</b>             | ---    |

**Table 4:** Additional elements in consumer ports A and/or B

| Additional element   | Coding <sup>3) 4)</sup>  |                                | ∅ (mm) |
|--|--------------------------|--------------------------------|--------|
|  | all flow pattern symbols | only flow pattern symbols G, D |        |
| Orifice in A and/or B   | <b>AB 0,3</b>            | <b>BB 0,3</b>                  | 0,3    |
|  | <b>AB 0,4</b>            | <b>BB 0,4</b>                  | 0,4    |
|  | <b>AB 0,5</b>            | <b>BB 0,5</b>                  | 0,5    |
|  | <b>AB 0,6</b>            | <b>BB 0,6</b>                  | 0,6    |
|  | <b>AB 0,7</b>            | <b>BB 0,7</b>                  | 0,7    |
|  | <b>AB 0,8</b>            | <b>BB 0,8</b>                  | 0,8    |
|  | <b>AB 0,9</b>            | <b>BB 0,9</b>                  | 0,9    |
|  | <b>AB 1,0</b>            | <b>BB 1,0</b>                  | 1,0    |
|  | <b>AB 1,2</b>            | <b>BB 1,2</b>                  | 1,2    |
|  | <b>AB 1,5</b>            | <b>BB 1,5</b>                  | 1,5    |
|  | <b>AB 2,0</b>            | <b>BB 2,0</b>                  | 2,0    |
|  | <b>AB 2,5</b>            | <b>BB 2,5</b>                  | 2,5    |
| Restrictor check valve at A and/or B throttling the flow to the consumer    | <b>ABV 0,6</b>           | <b>BBV 0,6</b>                 | 0,6    |
|  | <b>ABV 0,7</b>           | <b>BBV 0,7</b>                 | 0,7    |
|  | <b>ABV 0,8</b>           | <b>BBV 0,8</b>                 | 0,8    |
|  | <b>ABV 0,9</b>           | <b>BBV 0,9</b>                 | 0,9    |
|  | <b>ABV 1,0</b>           | <b>BBV 1,0</b>                 | 1,0    |
|  | <b>ABV 1,2</b>           | <b>BBV 1,2</b>                 | 1,2    |
|  | <b>ABV 1,5</b>           | <b>BBV 1,5</b>                 | 1,5    |
|  | <b>ABV 2,0</b>           | <b>BBV 2,0</b>                 | 2,0    |
| Restrictor check valve at A and/or B throttling the flow from the consumer  | <b>ABR 0,6</b>           | <b>BBR 0,6</b>                 | 0,6    |
|  | <b>ABR 0,7</b>           | <b>BBR 0,7</b>                 | 0,7    |
|  | <b>ABR 0,8</b>           | <b>BBR 0,8</b>                 | 0,8    |
|  | <b>ABR 0,9</b>           | <b>BBR 0,9</b>                 | 0,9    |
|  | <b>ABR 1,0</b>           | <b>BBR 1,0</b>                 | 1,0    |
|  | <b>ABR 1,2</b>           | <b>BBR 1,2</b>                 | 1,2    |
|  | <b>ABR 1,5</b>           | <b>BBR 1,5</b>                 | 1,5    |
|  | <b>ABR 2,0</b>           | <b>BBR 2,0</b>                 | 2,0    |

**Table 5:** Pressure switches and/or pressure gauges at ports A and/or B

|   | Coding dep. on flow pattern symbols |   |  |
|---|-------------------------------------|---|--|
|   | R, S, B, Z, Y <sup>1)</sup>         | ZD, G, D, DS, W, Q, RS, SR, K, J Connection A | G, D, DS, Q, RS, SR, W, K Connection B |
| Pressure switch/metering range (adjustable range (bar)) |                                     |   |  |
| without DG (prepared for retrofitting)                  | <b>2</b>                            | ---   | ---                                    |
| DG 33 (200...700) acc. to D 5440                        | <b>3</b>                            | <b>A3</b>                                     | <b>B3</b>                              |
| DG 34 (100...400)                                       | <b>4</b>                            | <b>A4</b>                                     | <b>B4</b>                              |
| DG 35 (20...250)  | <b>5</b>                            | <b>A5</b>                                     | <b>B5</b>                              |
| DG 36 (4...12)  | <b>6</b>                            | <b>A6</b>                                     | <b>B6</b>                              |
| DG 365 (12...170)                                       | <b>7</b>                            | <b>A7</b>                                     | <b>B7</b>                              |
| DG 364 (4...50)   | <b>8</b>                            | <b>A8</b>                                     | <b>B8</b>                              |
| DG 5 E-100 acc. to D 5440 E/1                           | <b>5E1</b>                          | <b>A5E1</b>                                   | <b>B5E1</b>                            |
| DG 5 E-250  | <b>5E2</b>                          | <b>A5E2</b>                                   | <b>B5E2</b>                            |
| DG 5 E-400  | <b>5E4</b>                          | <b>A5E4</b>                                   | <b>B5E4</b>                            |
| DG 5 E-600  | <b>5E6</b>                          | <b>A5E6</b>                                   | <b>B5E6</b>                            |
| DG 61 acc. to D 5440 F                                  | <b>6E1</b>                          | <b>A6E1</b>                                   | <b>B6E1</b>                            |
| DG 61 R   | <b>6ER1</b>                         | <b>A6ER1</b>                                  | <b>B6ER1</b>                           |
| DG 62   | <b>6E2</b>                          | <b>A6E2</b>                                   | <b>B6E2</b>                            |
| DG 62 R   | <b>6ER2</b>                         | <b>A6ER2</b>                                  | <b>B6ER2</b>                           |
| DG 64   | <b>6E4</b>                          | <b>A6E4</b>                                   | <b>B6E4</b>                            |
| DG 64 R   | <b>6ER4</b>                         | <b>A6ER4</b>                                  | <b>B6ER4</b>                           |
| Pressure gauge with scale up to (bar) acc. to D 7077    |                                     |   |  |
| 100   | ---                                 | <b>A9/100</b>                                 | <b>B9/100</b>                          |
| 160   | ---                                 | <b>A9/160</b>                                 | <b>B9/160</b>                          |
| 250   | ---                                 | <b>A9/250</b>                                 | <b>B9/250</b>                          |
| 400   | ---                                 | <b>A9/400</b>                                 | <b>B9/400</b>                          |
| 600   | ---                                 | <b>A9/600</b>                                 | <b>B9/600</b>                          |

Examples:  
NBVP 16 Y/R/5-GM 24

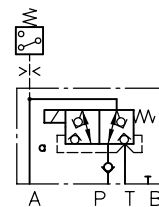

NBVP 16 G/A9/400 B9/400-G 24

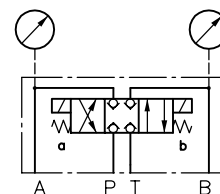





1) Mounting of a pressure gauge or another additional element instead of the pressure switches is possible via the fitting Y9-X84.. acc. to D 7077  
 2) With ports G 1/8 (BSP) for pressure gauge  
 3) Part No. for spare parts order etc. see section 5.1 "Appendix"  
 4) Versions A(B) BR.. and A(B) BV.. are identical, only install position differs (see illustration sect. 1)  
 5) not available with symbol B

**Table 6:** Additional elements at port T

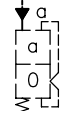
| Additional element  | Coding       | Open-up pressure |
|---|--------------|------------------|
| without   | ---          |                  |
| Return pressure stop (check valve)<br> | <b>S</b>     | approx. 0.07 bar |
|   | <b>S 0,2</b> | approx. 0.2 bar  |
|   | <b>S 1</b>   | approx. 1.0 bar  |

**Table 7:** Actuation modes

| Actuation          | Pressure $p_{max}$ (bar) <sup>4)</sup>  | for symbols   | Coding   |   |   | Main data, also see section 3.2   |
|--------------------|---|---|--|---|---|---|
|                    |   |   | With plug  | Plug with LED   | Without plug  |   |
| Solenoid           | 400   | R, S, B, Z, Y, ZD<br>Q, K, RS, SR, W <sup>5)</sup><br>J, G, D, DS                   | <b>G 12</b><br><b>G 24</b><br><b>WG 110</b> <sup>2)</sup><br><b>WG 230</b> <sup>2)</sup>                                       | <b>L 12</b><br><b>L 24</b><br>---<br>---  | <b>X 12</b><br><b>X 24</b><br><b>X 98</b><br><b>X 205</b>                             | $U_N = 12$ V DC<br>$U_N = 24$ V DC<br>$U_N = 110$ V AC, 50/60 Hz (98 V DC)<br>$U_N = 230$ V AC, 50/60 Hz (205 V DC) |
|                    | 250   | R, S, B, Z, Y, ZD<br>Q, K, RS, SR,<br>J, G, D, DS                                   | <b>GM 12</b> <sup>3)</sup><br><b>GM 24</b> <sup>3)</sup><br><b>WGM 110</b> <sup>2) 3)</sup><br><b>WGM 230</b> <sup>2) 3)</sup> | <b>LM 24</b><br><b>LM 24</b><br>---<br>---  | <b>XM 12</b><br><b>XM 24</b><br><b>XM 98</b><br><b>XM 205</b>                         | $U_N = 12$ V DC<br>$U_N = 24$ V DC<br>$U_N = 110$ V AC, 50/60 Hz (98 V DC)<br>$U_N = 230$ V AC, 50/60 Hz (205 V DC) |
|                    | 250   | R, S, B, Z, Y,<br>K, RS, SR, J,<br>G, D, DS   | <b>M 24/8W</b>   | ---   | ---   | $U_N = 24$ V DC, 8 Watt   |
|                    | 250   | R, S, B, Y, ZD,<br>K, RS, SR, J,<br>G, D, DS  | <b>G 24 EX</b> <sup>1)</sup>   | ---   | ---   | $U_N = 24$ V DC   |
| 400                | Z   |   |  |   |   |   |
| Hydraulic          | 400   | R, S, B, Z, Y,<br>Q, K, RS, SR, W <sup>5)</sup><br>J, G, D, DS                      | <b>H 1/4</b>   | External control G 1/4 (BSPP)   |   | Control pressure: $p_{contr min} = 24$ bar<br>$p_{contr max} = 400$ bar   |
| Pneumatic          | 400   |   | <b>P</b>   | External control G 1/4 (BSPP)   |   | Control pressure: $p_{contr min} = 3$ bar<br>$p_{contr max} = 15$ bar   |
| Mechanical         | 400   | R, S, B, Z, Y,<br>Q, K, RS, SR, W <sup>5)</sup>                                     | <b>T</b>   | Pin   |   | Actuation force: $F = \text{appr. } 80 \dots 190$ N   |
|                    |   |   | <b>K</b>   | Roller  |   | Actuation force: $F = \text{appr. } 22 \dots 35$ N  |
| Manual             |   |   | <b>A</b>   | with hand lever (spring return)   |   | Actuation moment: $\text{appr. } 1.5 \dots 3$ Nm  |
| Manual with detent |   |   | <b>CD</b>  | With hand lever   |   | Actuation moment: $\text{appr. } 1.5 \dots 3$ Nm  |
|                    |   |   | <b>KD</b> <sup>6)</sup>  | Without hand lever  |   |   |
| Symbole            | Solenoid  | Hydraulic   | Pneumatic  | Pin   | Mechanical  | Manual  |
|                    |   | <b>H 1/4</b>  | <b>P</b>   | Pin <b>T</b>  | Roller <b>K</b>   | <b>A</b>  |
|                    |  |  |   |  |  |                                |

**Table 7 a:** Additional lock at actuation CD, KD with detent

|          |                       |          |                             |
|----------|-----------------------|----------|-----------------------------|
| --       | without (no coding)   | <b>2</b> | in working position a       |
| <b>1</b> | in working position b | <b>3</b> | in working position a and b |

Symbole

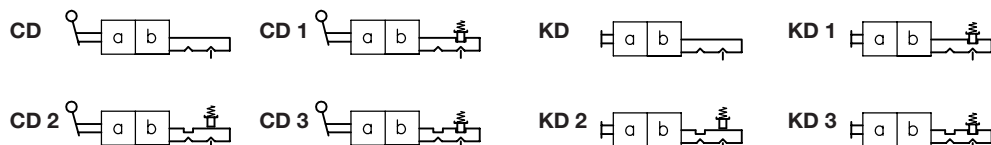

- 1) Explosion-proof version ( $p_{max T} = 250$  bar with symbol Z)
- 2) DC-solenoid (98 V DC, 205 V DC) with bridge rectifier in the plug
- 3) Versions GM, WGM, LM, XM are priced lower than version G, WG etc.; Observe their reduced pressure rating!
- 4) Observe the max. pressure specification at T (see sect. 3.1)
- 5) Symbol W permissible pressure  $p_{max} = 250$  bar
- 6) Actuation with tool a/f 13

### 3. Further characteristic data

#### 3.1 General and hydraulic data

Installed position Any  
 Overlap at Negative (overlap only apparent during transition from one to the other end position).  
 3/2-way valves All ports are interconnected during the switching process.  
 Operating pressure  $p_{max}$  acc. to table 7, sect. 2.1  
 $p_{max T} = p_{max}$  - symbols R, S, Z, Y  
 = 250 bar - symbol Z (- G 24 EX)  
 = 250 bar - symbol ZD  
 = 50 bar - symbols B, Q, K, RS, SR, W, G, D, DS  
 The pressure at T has to be always be lower than the pressure apparent at P or A and B  
 Static overload capacity Ports P, A, and B approx.  $2 \times p_{max}$   
 Housing material and surface coating Steel, gas nitrided (basic valve)

| Mass (weight) approx. kg | Complete with actuation          | NBVP 16 B<br>NBVP 16 R<br>NBVP 16 S | NBVP 16 Z<br>NBVP 16 Y | NBVP 16 ZD<br>(Q, K, RS, SR, W) | NBVP 16 G (J)<br>NBVP 16 D (DS) |
|--------------------------|----------------------------------|-------------------------------------|------------------------|---------------------------------|---------------------------------|
| Solenoid                 | G., G 24 EX,<br>L., X., WG., M.. | 1.5                                 | 1.7                    | 2.1                             | 2.4                             |
|                          | GM.,LM.,<br>XM., WGM..           | 1.4                                 | 1.6                    | 1.9                             | 2.2                             |
| Hydraulic                | H 1/4                            | 1.1                                 | 1.3                    | 2.3                             | 3.0                             |
| Pneumatic                | P                                | 1.0                                 | 1.2                    | 1.6                             | 1.6                             |
| Manual                   | A                                | 1.4                                 | 1.6                    | 2.0                             | ---                             |
| Manual with detent       | CD, KD                           | 1.4                                 | 1.6                    | 1.9                             | ---                             |
| Mechanical               | T                                | 1.1                                 | 1.3                    | 1.7                             | ---                             |
|                          | K                                | 1.4                                 | 1.6                    | 2.0                             | ---                             |

per pressure switch + 0.3

Pressure fluid Hydraulic oil conforming DIN 51524 part 1 to 3: ISO VG 10 to 68 conforming DIN 51519.  
 Viscosity limits: min. approx. 4, max. approx. 1500 mm<sup>2</sup>/s; opt. operation approx. 10... 500 mm<sup>2</sup>/s.  
 Also suitable are biologically degradable pressure fluids types HEPG (Polyalkylenglycol) and HEES (Synth. Ester) at service temperatures up to approx. +70°C.

Temperature Ambient: approx. -40...+80°C; Fluid: -25...+80°C, pay attention to the viscosity range!  
 Start temperature down to -40°C are allowable (Pay attention to the viscosity range during start!), as long as the operation temperature during subsequent running is at least 20K higher. Biological degradable pressure fluids: Pay attention to manufacturer's information. With regard to the compatibility with sealing materials do not exceed +70°C.

**Restrictions for version with ex-proof solenoid!**

**Attention:** Observe the restrictions regarding the perm. duty cycles of the solenoids in sect. 3.2!

Flow  $Q_{max} = 20$  lpm  
 Trigger point for valves with switching position monitoring  $Q \leq 1$  lpm

Flow limitation It is necessary to limit the flow down to the permissible range depending on the system pressure via orifices (see sect. 2.1). This applies to all circuits fed by an accumulator or when connected to high pressure circuits fed by high delivery pumps.  
 The orifice must be located on the accumulator side always. For more detailed information, see table 3 and 4, section 2.1.  
 The check valves (see table 3 and 6 in sect. 2.1) prevent an undesired reversal of the flow direction.

**Δp-Q curve**

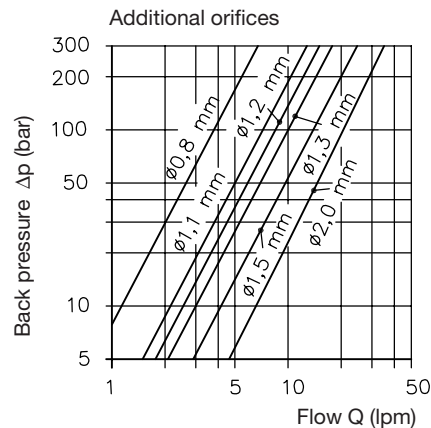
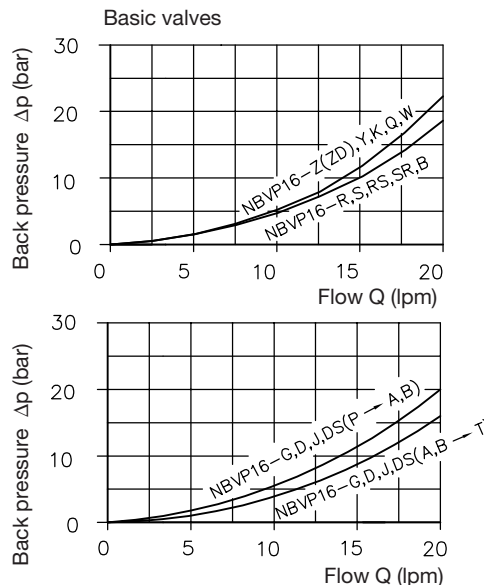

Electrical data for contact switch

|                                       |   |                           |
|---------------------------------------|---|---------------------------|
| Type                                  | V4NC SET 7 Co. SAIA-Burgess   |                           |
| Mech. service life                    | 5 x 10 <sup>6</sup>   |                           |
| Electr. service life (approx. cycles) | 12 V, 3 A = 0,05 x 10 <sup>6</sup> , 100 mA = 3 x 10 <sup>6</sup> (cos φ = 1)   |                           |
| Power supply                          | 12 V DC, 5 A<br>24 V DC, 5 A  |                           |
|                                       | To ensure save function the min. current specifications must be maintained; I <sub>min</sub> (12 V DC) = 10 mA, I <sub>min</sub> (24 V DC) = 100 mA |                           |
| Plug                                  | DIN EN 175 301-803  | M12x1                     |
| Protection class (properly assembled) | IP 65 (acc. to IEC 60529)   | IP 67 (acc. to IEC 60529) |
| Circuitry                             | Idle position 1-3<br>Working position 1-2   | Working position 1-4      |

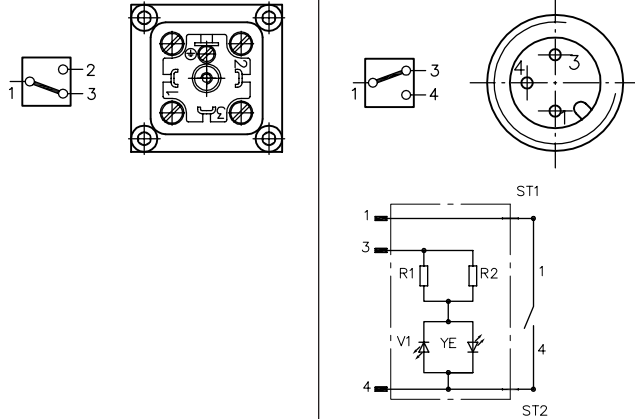

### 3.2 Actuators

#### Solenoid

|  |           |  |       |           |       |              |         |                          |         |        |         |  |  |
|--|-----------|--|-------|-----------|-------|--------------|---------|--------------------------|---------|--------|---------|--|--|
|  |           | All solenoids are built and tested acc. to VDE 0580  |       |           |       |              |         |                          |         |        |         |  |  |
| Coding   |           | G 12   | GM 12 | G 24      | GM 24 | G 24 EX      | M 24/8W | WG 110                   | WGM 110 | WG 230 | WGM 230 |  |  |
|  |           | L 12   | LM 12 | L 24      | LM 24 | ---          | ---     | ---                      | ---     | ---    | ---     |  |  |
|  |           | X 12   | XM 12 | X 24      | XM 24 | ---          | ---     | ---                      | ---     | ---    | ---     |  |  |
| Nom. voltage   | $U_N$ (V) | 12   | 12    | 24        | 24    | 24           | 24      | 110                      | 110     | 230    | 230     |  |  |
|  |           | DC-voltage   |       |           |       |              |         | AC-voltage, 50 and 60 Hz |         |        |         |  |  |
| Nom. power   | $P_N$ (W) | 29.4   | 26.2  | 27.6      | 26.5  | 23.4         | 8       | 28.6                     | 24.8    | 30.2   | 28      |  |  |
| Connection and circuitry<br>Vers. G, GM, L, LM, WG, WGM:<br>All plugs<br>DIN EN 175 301-803<br><br>For additional plugs, see D 7163<br><br>Version G 24 EX:<br>Cable cross section 3x0.5 mm <sup>2</sup> ,<br>Cable length 3 m, Option 10 m<br>(cable ÖLFLEX-440P ® Co.<br>LAPP, D-70565 Stuttgart)<br><br>Version M 24/8W:<br>Plug M12x1 - DESINA |           | DC-voltage<br>Type G...<br>(applies also to<br>contact switch)                             |       | Type L... |       | Type M 24/8W |         | AC-voltage<br>Type WG..  |         |        |         |  |  |
|  |           |  |       |           |       |              |         |                          |         |        |         |  |  |
|  |           | 1) Terminals 1+ 2 optionally for diagnosis   |       |           |       |              |         |                          |         |        |         |  |  |
| Switching time (reference value)   |           | On or Off: approx. 50...60 ms, at M 24/8W and longer with WG...                            |       |           |       |              |         |                          |         |        |         |  |  |
| Switching/hour   |           | approx. 2000, approximately evenly distributed   |       |           |       |              |         |                          |         |        |         |  |  |
| Min. pulse duration  |           | approx. 500 ms with flow pattern ZD  |       |           |       |              |         |                          |         |        |         |  |  |
| Protection class   |           | IP 65 (IEC 60529)<br>(plug properly mounted)<br>IP 67 (IEC 60529 with G 24 EX and M 24/8W) |       |           |       |              |         |                          |         |        |         |  |  |
| Insulation material class  |           | F  |       |           |       |              |         |                          |         |        |         |  |  |
| Contact temperature  |           | approx. 120°C, with ambient temperature 20°C   |       |           |       |              |         |                          |         |        |         |  |  |
| Switch-off energy  |           | $W_A \leq 0.4$ Ws  |       |           |       |              |         |                          |         |        |         |  |  |
| Surface coating (solenoid)   |           | DIN 50961-Fe/Zn 12 bk cC   |       |           |       |              |         |                          |         |        |         |  |  |

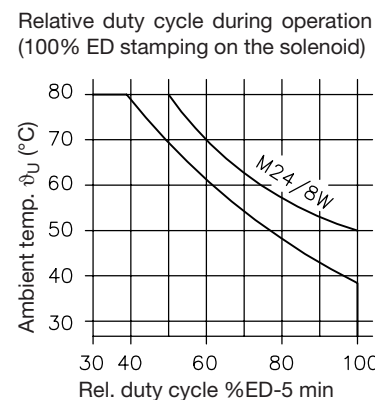

#### Electrical data for ex-proof solenoids

ATEX-Certificate of conformity  
Coding

TÜV-A 12ATEX 0006 X  
⊕ II 2 G Ex d IIB + H2 T4 Gb  
⊕ II 2 D Ex tb IIIC T135°C Db

Oper. duration  
Duty cycle  
Nom. voltage  $U_N$   
Power  $P_N$

100% ED  
IP 67 (IEC 60529)  
24 V DC  
23 W

#### Restrictions for use:

Ambient temperature  
max. fluid temperature  
el. protection against overload (conf. IEC 60127)  
Surface coating

-35 ... +40°C  
+70°C  
 $I_F < 1.6$  A-T  
Housing galvanically zinc coated  
Coil and connection cavity are moulded

**Attention:** Protect the complete valve against direct sun light.

Observe the operation manuals B 03/2004 and B ATEX!  
Electrical lay-out and testing conforming EN 60079, VDE 0170-1, VDE 0170-5

Circuitry switching position monitoring: Version .KM (plug M12x1)

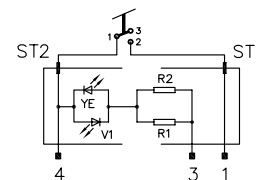

|  |                  | Hydraulic                                  | Pneumatic                                       | Manual                                | Mechanical                              |                |
|--|------------------|--|---|---------------------------------------|---|----------------|
|  |                  | (coding H 1/4)                             | (coding P)                                      | (coding A, CD, KD)                    | (coding T)                              | (coding K)     |
| Control pressure   | $p_{contr\ min}$ | 24 bar                                     | 3 bar   | ---                                   | ---                                     | ---            |
|  | $p_{contr\ max}$ | 400 bar                                    | 15 bar  | ---                                   | ---                                     | ---            |
| Permissible residual pressure in the control line for safe return into the idle position |                  | < 2 bar                                    | ---   | ---                                   | ---                                     | ---            |
| Z static overload capacity   |                  | appr. 1.5 $p_{contr\ max}$ bar             | appr. 1.5 $p_{contr\ max}$ bar                  | ---                                   | ---                                     | ---            |
| Control displacement (geometric)   |                  | 1.4 cm <sup>3</sup>                        | 9.3 cm <sup>3</sup>                             | ---                                   | ---                                     | ---            |
| Housing material and surface coating   |                  | Steel (control housing)<br>zinc galvanized | Light alloy (control housing)<br>black anodized | Steel (lever housing)<br>gas nitrided | Steel (control housing)<br>gas nitrided | ---            |
| Actuation moment   |                  | ---  | ---   | appr. 1.5 ... 3 Nm                    | ---                                     | ---            |
| Actuation force  |                  | ---  | ---   | ---                                   | appr. 80..190 N                         | appr. 22..35 N |

## 4. Unit dimensions All dimension in mm and subject to change without notice!

### 4.1 Hole pattern at the manifold (top view)

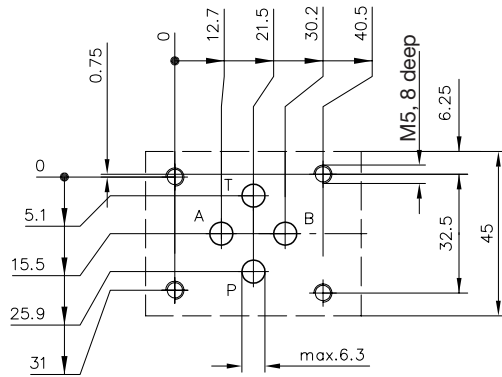

### 4.2 Valve section

- Type NBVP 16 G
- NBVP 16 D
- NBVP 16 DS
- NBVP 16 J
- NBVP 16 Q
- NBVP 16 K
- NBVP 16 RS
- NBVP 16 SR
- NBVP 16 W

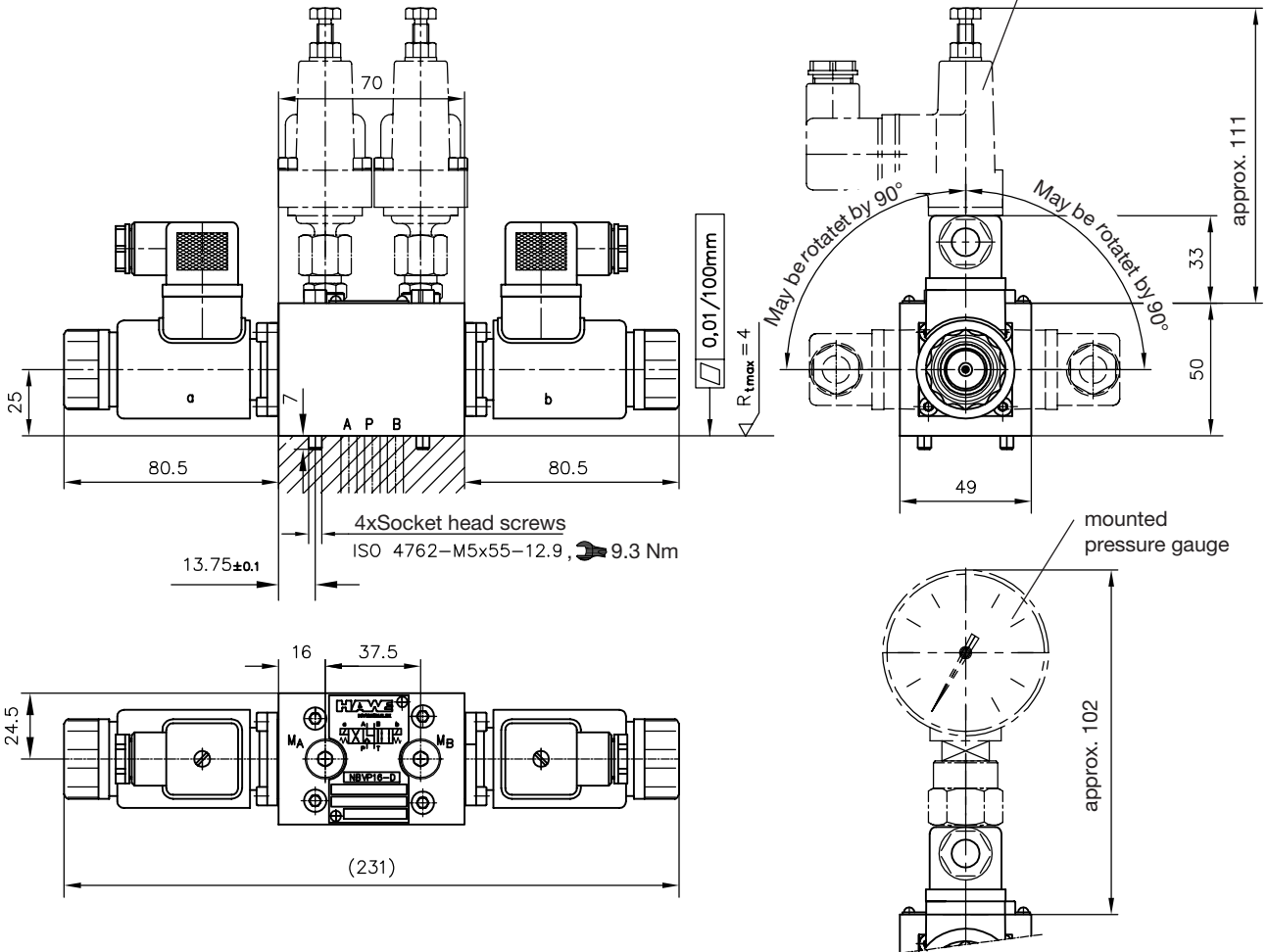
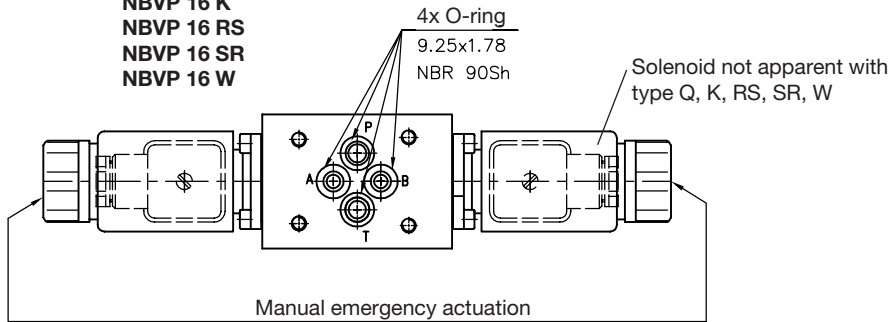

Type NBVP 16 R  
 NBVP 16 S  
 NBVP 16 B  
 NBVP 16 Z  
 NBVP 16 Y

Type NBVP 16 ZD

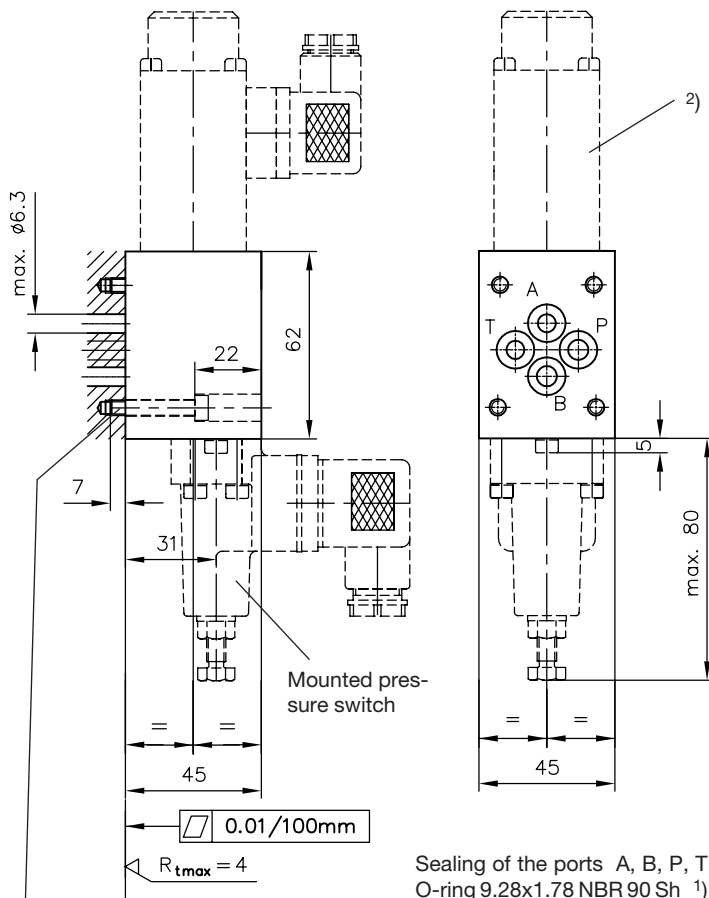

4x Socket head screws  
 ISO 4762-M5x30-12.9,  $\Rightarrow$  9.3 Nm

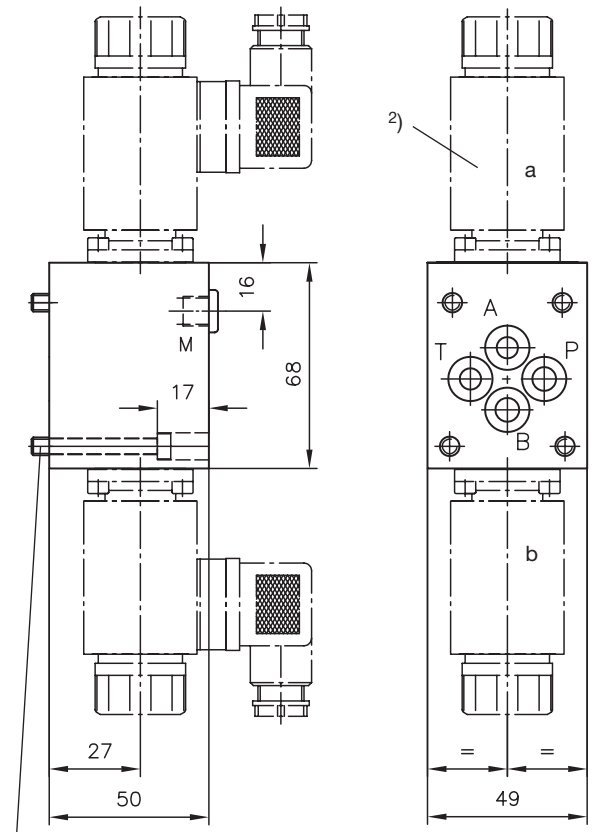

4x Socket head screws  
 ISO 4762-M5x40-12.9,  $\Rightarrow$  9.3 Nm

- 1) Part of seal kit DS 7765-1 (including O-rings for actuation, H 1/4)
- 2) For dimension of the differing actuations, see section 4.3!

Type NBVP 16 RK  
 NBVP 16 SK  
 NBVP 16 ZK  
 NBVP 16 YK

Type NBVP 16 RKM  
 NBVP 16 SKM  
 NBVP 16 ZKM  
 NBVP 16 YKM

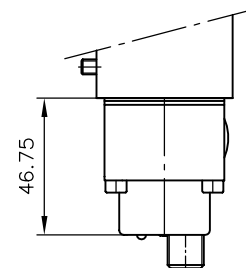
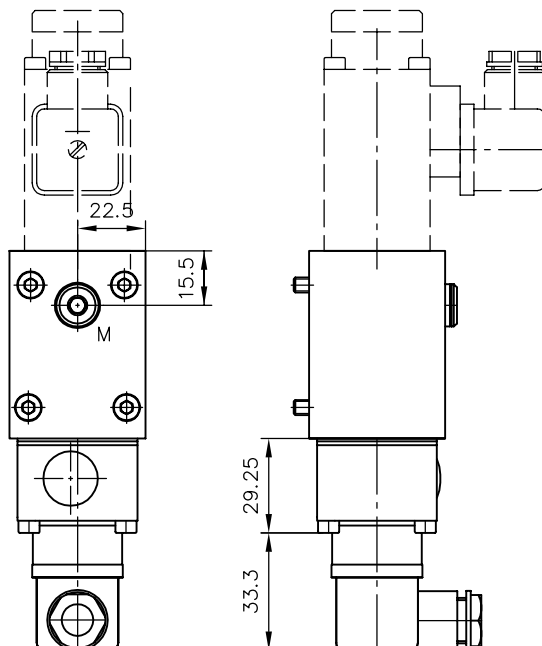

For missing dimensions, see above

### 4.3 Control elements

#### Electrical actuation

##### Coding G and WG

Symbols R, S, B, Z, Y

Symbols Q, RS, SR, K, W, ZD, G, D, DS, J

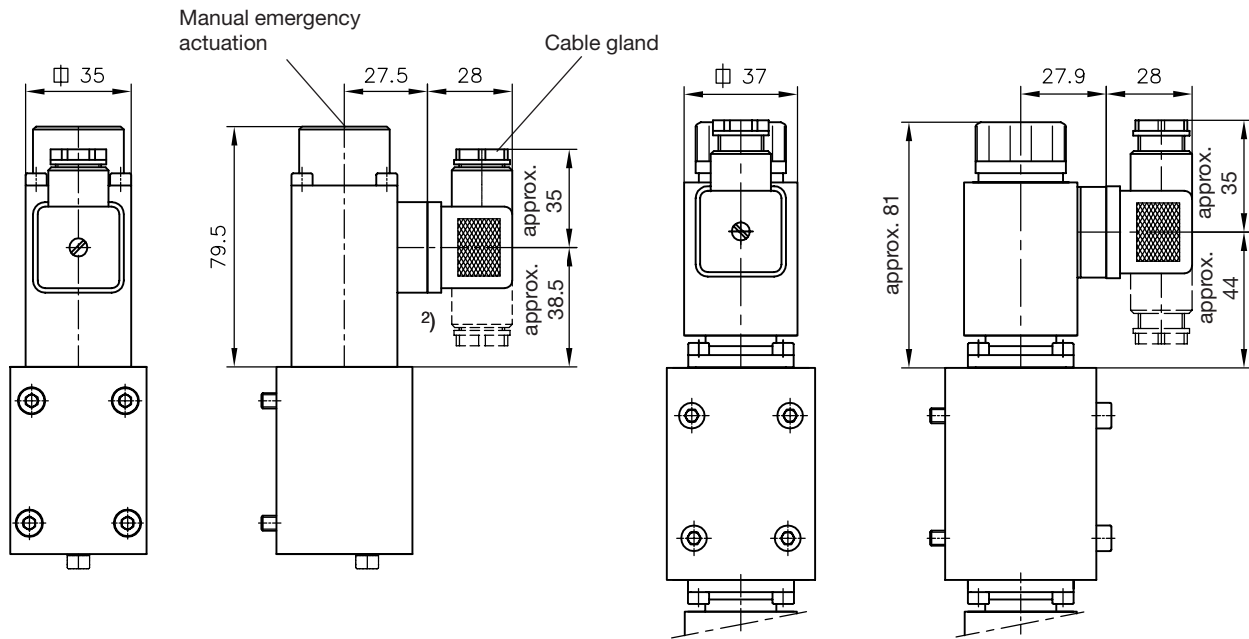

- 1) **Note:** This dimension depends on the manufacturer and may be max. 40 mm acc. DIN EN 175 301-803!  
 2) Solenoid may be installed off-set by 4x90°. Plug may be installed off-set by 2x180°.

##### Coding GM and WGM

(all symbols beside W)

##### Manual emergency actuation

(applies to all solenoid versions)

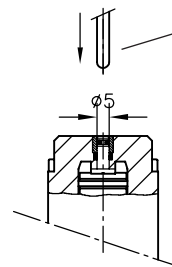
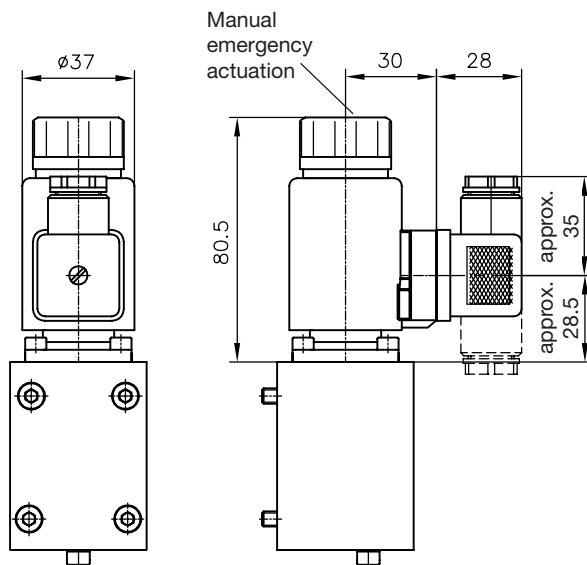

Actuation aid (do not use any sharp-edged parts)

The valve can be actuated, if required, by pushing the emergency actuation pin inward (visible from the top side) by means of a screw driver or similar.

**Note:**

The pressure at port B acts on the cross section area of the brass pin  $\varnothing 5$ , i.e. 100 bar will result in 195 N!

Continuation „Solenoid actuation“

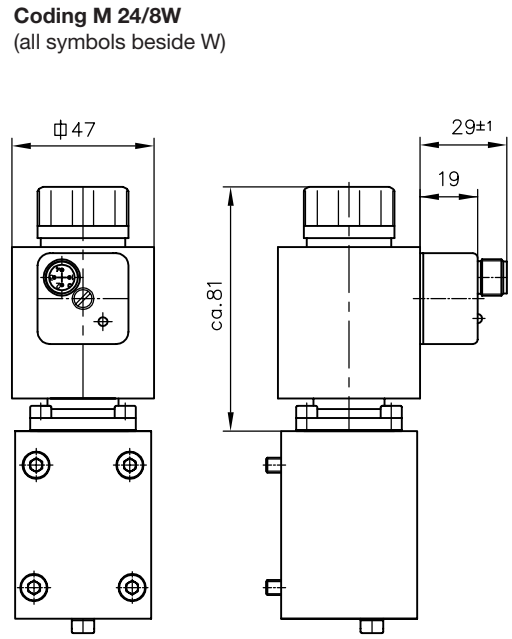
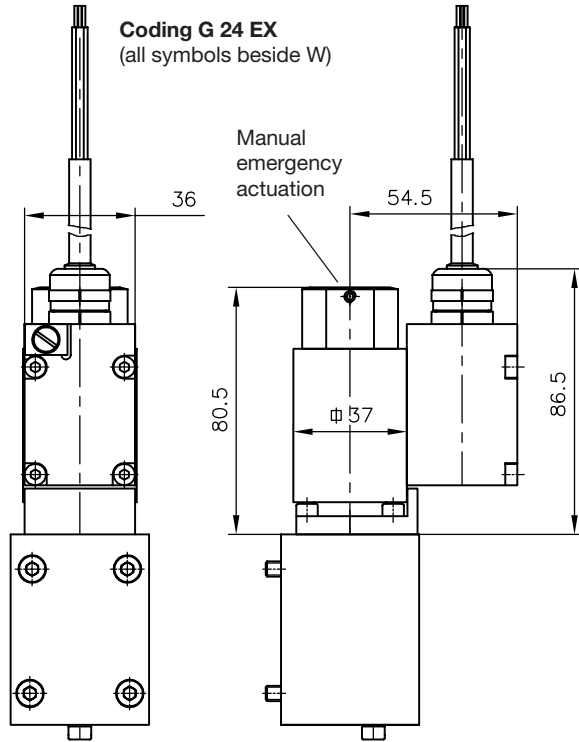

**Hydraulic 1)**  
**Coding H 1/4**

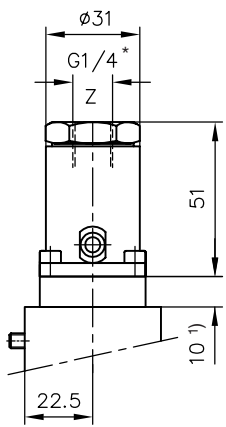

**Pneumatic 1)**  
**Coding P**

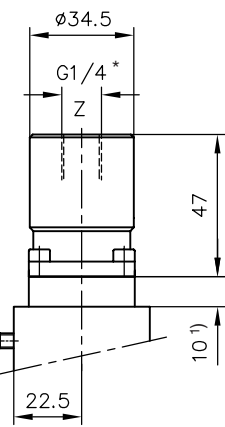

\* = BSPP

**Manual 1)**  
**Coding A**

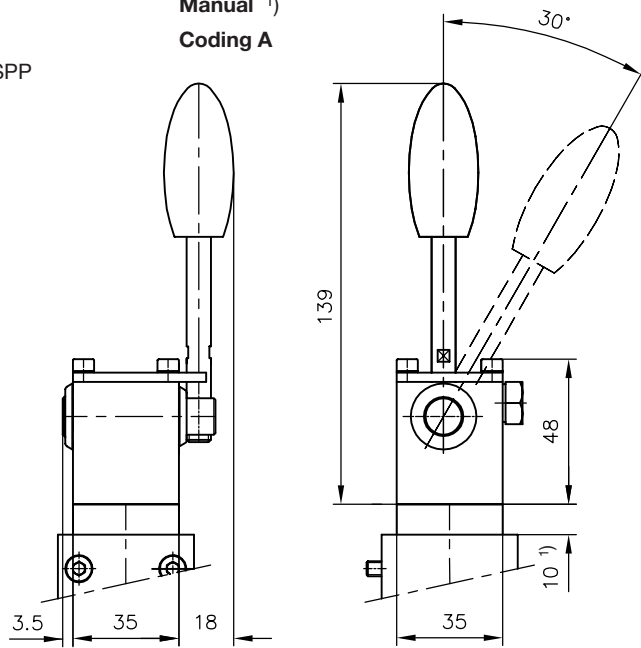

1) intermediate plate apparent with symbols Q, K, RS, SR, W, D, DS, J, G

**Manual with detent**  
**Coding CD, KD**

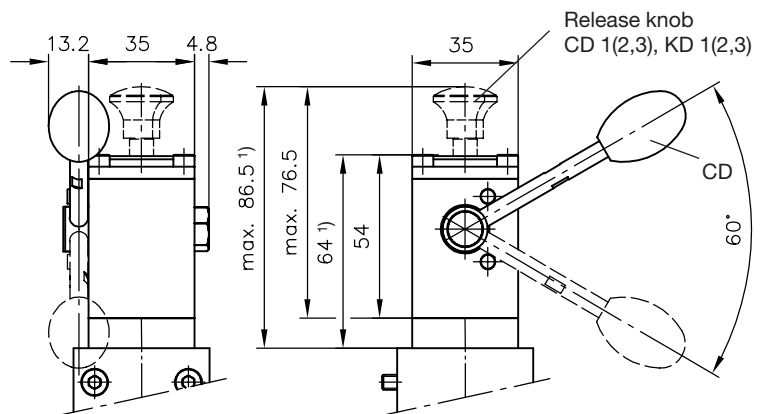



## 4.4 Sub-plate for pipe connection

Coding -3/8

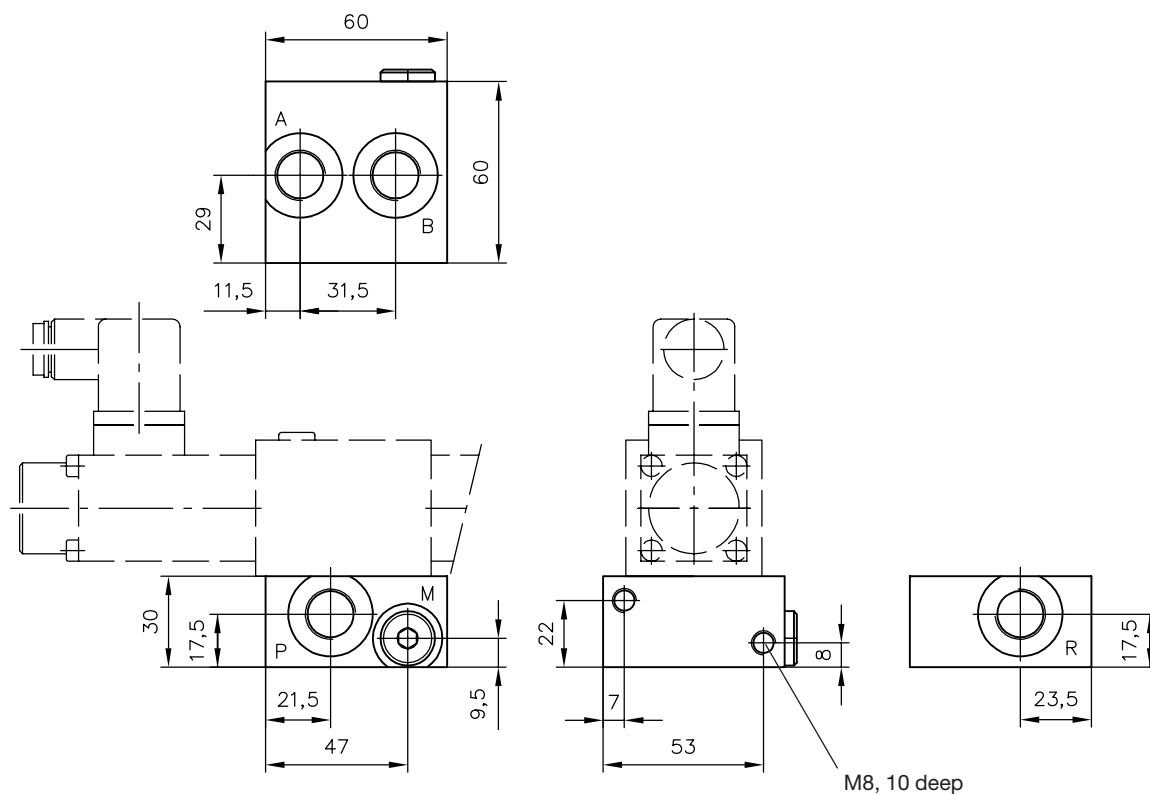

Ports conf. ISO 228/1 (BSPP):

P, R, A, B = G 3/8

M = G 1/4 (plugged, no function)

## 5. Appendix

### 5.1 Parts No. of the orifices, when ordering spare parts

| Coding       | Parts No.                    | Coding             | Parts No.                 |               |                           |
|--------------|------------------------------|--------------------|---------------------------|---------------|---------------------------|
| <b>B ...</b> | Grub screw                   | <b>S</b>           | ER 14                     |               |                           |
|              | ISO 4026 - M8x8 - ... - 10.9 |                    | ER 14/0,2                 |               |                           |
| ↳ Diameter   | ER 14/1                      |                    |                           |               |                           |
| <b>R</b>     | ER 13                        | <b>ABV ...</b>     | EBR 14-B...<br>↳ Diameter |               |                           |
|              |                              |                    |                           |               |                           |
|              |                              |                    |                           | <b>AB ...</b> | 7966 003 m (without hole) |
|              |                              |                    |                           |               | <b>BB ...</b>             |
|              |                              | 7966 003 i (∅ 0.4) |                           |               |                           |
|              |                              | 7966 003 k (∅ 0.5) |                           |               |                           |
|              |                              | 7966 003 l (∅ 0.6) |                           |               |                           |
|              |                              | 7966 003 a (∅ 0.7) |                           |               |                           |
|              |                              | 7966 003 n (∅ 0.8) |                           |               |                           |
|              |                              | 7966 003 f (∅ 0.9) |                           |               |                           |
|              |                              | 7966 003 b (∅ 1.0) |                           |               |                           |
|              |                              | 7966 003 g (∅ 1.2) |                           |               |                           |
|              |                              | 7966 003 c (∅ 1.5) |                           |               |                           |
|              |                              | 7966 003 d (∅ 2.0) |                           |               |                           |
|              |                              | 7966 003 e (∅ 2.5) |                           |               |                           |