



OIL SOLUTIONS

PO Box 38
Strathfieldsaye, VIC, 3551
1800 OIL SOL
1800 645 765
sales@oilsolutions.com.au
www.oilsolutions.com.au
"For All Your Hydraulic Needs"



COMPONENTI PER
MICROCENTRALINE
COMPONENTS FOR
MICROPOWERBACK



MCR - BLOCCO CENTRALE

MCR - CENTRAL MANIFOLD

OMT Group ha studiato e prodotto una serie di componenti per la realizzazione di Minicentraline della serie **MCR**.

Questa serie permette all'utilizzatore di poter approntare un impianto oleodinamico semplice, versatile, compatto, economico e nel contempo affidabile.

La serie **MCR** si compone di un blocco centrale, realizzato nelle seguenti versioni:

- SEMPLICE EFFETTO
- DOPPIO EFFETTO
- DOPPIO EFFETTO CON POMPA MANUALE DI EMERGENZA
- REVERSIBILE.

Predisposto per montaggio di pompe oleodinamiche ad ingranaggi del **Gr.0 e Gr.1** accoppiate a motori in **C.A.** versione con flangia **B14** e motori in **C.C. 12/24 Volt**, tipo **Iskra**.

Tale blocco è predisposto per l'inserimento di valvole di massima pressione ed elettrovalvole. La trasmissione della potenza avviene per mezzo di un giunto rigido.

Inoltre esiste un'ampia scelta di serbatoi sia per il montaggio in orizzontale che in verticale. Con i serbatoi di forma circolare occorre utilizzare una apposita staffa di appoggio.

A completamento è prevista una serie di tubi (aspirazione e scarico) e filtri, appositamente studiati in funzione del tipo di pompa e dei serbatoi utilizzati.

MATERIALI

- Alluminio:** Blocco centrale, flange motori, blocchetti di connessione e serbatoi (CP).
- Acciaio con verniciatura antiolio:** Serbatoi (SER).
- Acciaio:** Tubi di aspirazione e scarico, valvole di sicurezza e di ritegno, staffa, giunto rigido, valvole di massima pressione.
- Acciaio/Ottone:** Filtri in aspirazione.
- Buna-N:** Guarnizioni.

I particolari di tale centralina, sono compatibili con oli minerali (tipo HH - HM - HR - HV - HG secondo ISO 6743/4) in un campo di temperatura compreso tra i -15°C e +80°C.

OMT Group has developed a range of components for the assembly of micro powerpacks, the **MCR** series. Their design permits the assembling of different versions with the result of a simple, compact, reliable and highly competitive product.

The **MCR** manifolds are available in the following versions:

- SINGLE EFFECT
- DOUBLE EFFECT
- DOUBLE EFFECT WITH EMERGENCY HANDPUMP
- REVERSE FLOW.

Made of high quality aluminium alloy it permits to mount **Gr. 0 and Gr. 1** standard gear pumps with **AC** electric motors (B14 standard motors) and **DC** motors (**12/24 V, ISKRA** brand).

It can be supplied fully machined with built-in adjustable relief valve and check valve on pressure port.

Power transmission from pump to motor is through a rigid monolithic coupling.

A large range of oiltanks is available for use in both horizontal and vertical installation.

To complete the range of components, various tubes (inlet/outlet) and filters have been developed to suit the different types of pumps and employed oiltanks.

MATERIALS

- Aluminium:** Central manifolds, motor flanges, modular elements, oil tanks (CP type).
- Painted steel:** Oiltanks (SER).
- Steel:** Inlet and outlet tubes, safety and check valves, foot flanges, rigid couplings, relief valves.
- Steel / Brass:** Suction filters.
- Nitrile (Buna-N):** Gaskets.

All the employed components are compatible with mineral oils (types HH - HM - HR - HV - HG according to ISO 6743/4).

Working temperature: -15°C e +80°C.

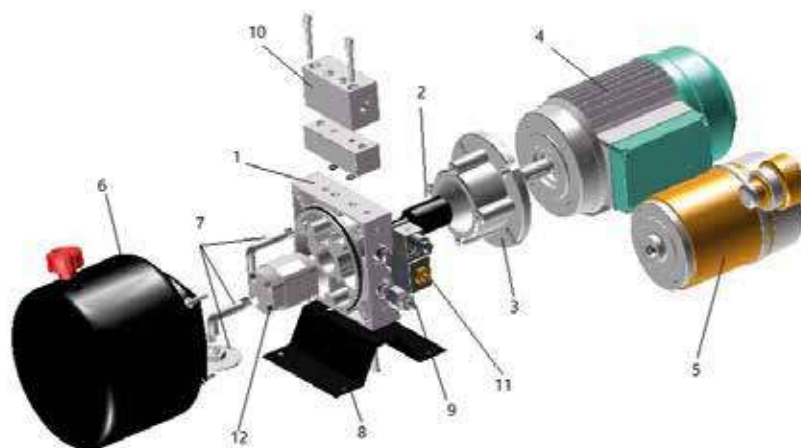

LEGENDA

- 1 - Blocco centrale
- 2 - Giunto
- 3 - Flangia motore
- 4 - Motore in c.a.
- 5 - Motore in c.c.
- 6 - Serbatoio olio
- 7 - Kit filtro e tubi
- 8 - Staffa
- 9 - Valvola di massima pressione
- 10 - Blocchetti di collegamento
- 11 - Elettrovalvola
- 12 - Pompa a ingranaggi

DESCRIPTION

- 1 - Central manifold
- 2 - Coupling
- 3 - Motor flange
- 4 - A.C. motor
- 5 - D.C. motor
- 6 - Oiltank
- 7 - Kit filter and tubes
- 8 - Foot flange
- 9 - Relief valve
- 10 - Modular elements
- 11 - Electric valve
- 12 - Gear pump

MOTORI UNIFICATI / STANDARD MOTORS

Flangia tipo B14 / Flange series B14

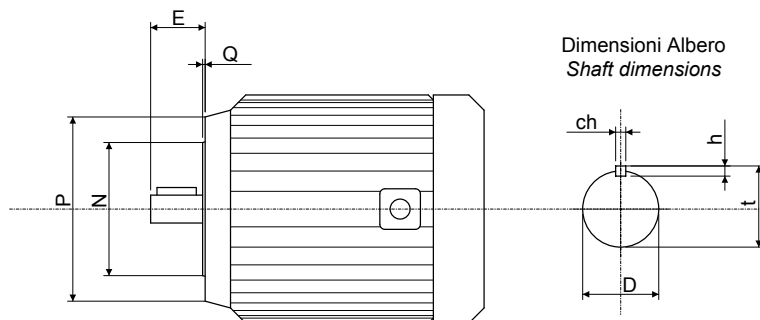

Taglia Size	Potenza / Power motor				Dimensioni / Dimensions							
	2 Poli/Poles		4 Poli/Poles		Dimensioni flangia / Flange dimensions			Dimensioni albero / Shaft dimensions				
	2900 giri/1' / revs/min		1450 giri/1' / revs/min		P	N	Q	D	E	ch	h	t
63	0.185	0.24	0.12	0.16	90	60	2.5	11	23	4	4	12.5
	0.25	0.35	0.185	0.25								
71	0.37	0.55	0.25	0.35	105	70	3	14	30	5	5	16
	0.55	0.75	0.37	0.55								
80	0.75	1	0.55	0.75	120	80	3	19	40	6	6	21.5
	1.1	1.5	0.75	1								
90S	1.5	2	1.1	1.5	140	95	3	24	50	8	7	27
90L	2.2	3	1.5	2								
100L	3	4	2.2	3	160	110	3.5	28	60	8	7	31
			3	4								
112M	4	5.5	4	5.5								

MOTORI IN CORRENTE CONTINUA / DC MOTORS

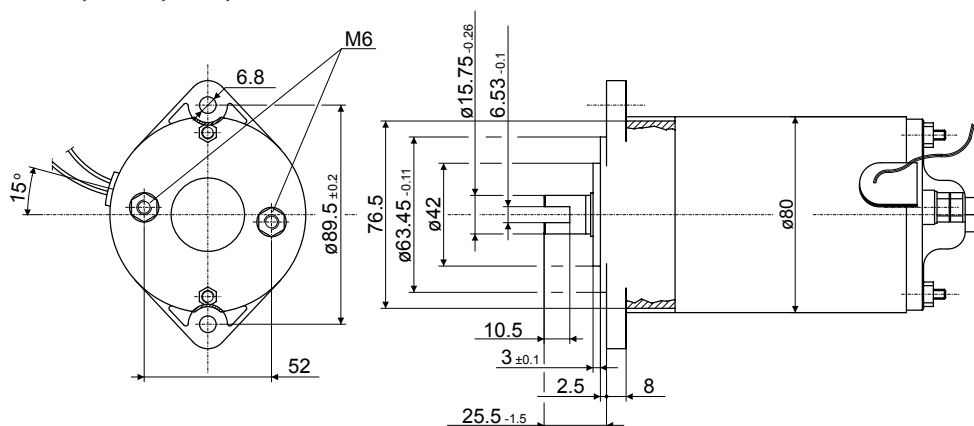
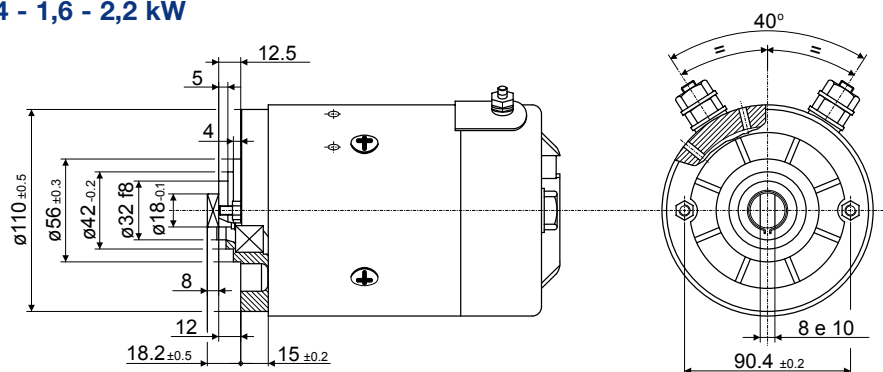
12/24V - $\varnothing 80$ - 0,15 - 0,5 - 0,8 kW12/24V - $\varnothing 114$ - 1,6 - 2,2 kW

Pompe gruppo 0,5 / Group 0.5 pump

Riferimento pompa / Pump reference

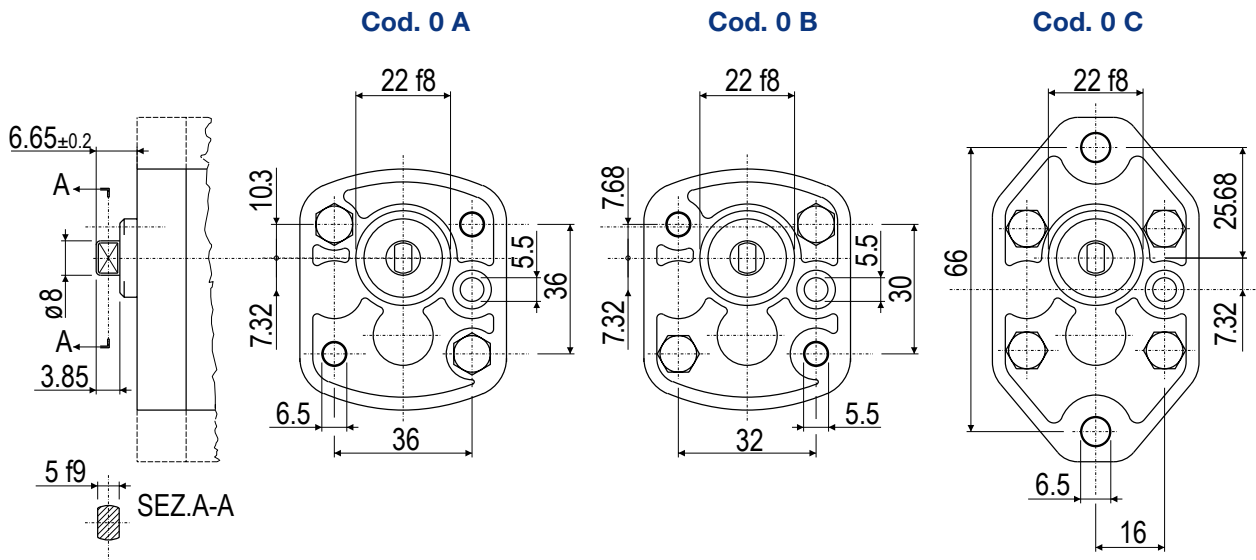

Cod. 0 D (Comprende tutte le forature sopraindicate) / (Including all the a.m. drillings)

Pompe gruppo 1 / Group 1 pump

Riferimento pompa / Pump reference Cod. 1 A

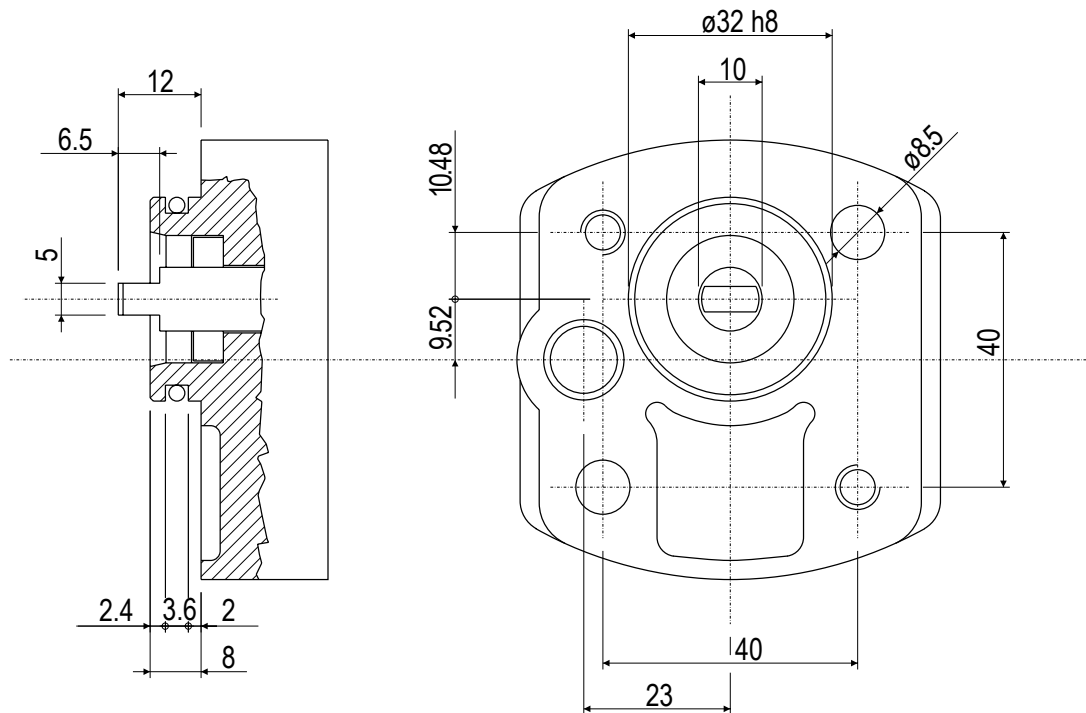

BLOCCO CENTRALE "SEMPLICE EFFETTO"
CENTRAL MANIFOLD "SIMPLE EFFECT"

Codice valvola di massima Relief valve part-number	Taratura Setting
MCR-V1-F	10-70 Bar
MCR-V2-F	35-140 Bar

Sede valida per valvola di massima ed elettrovalvola
 Seating for relief valve and electric valve

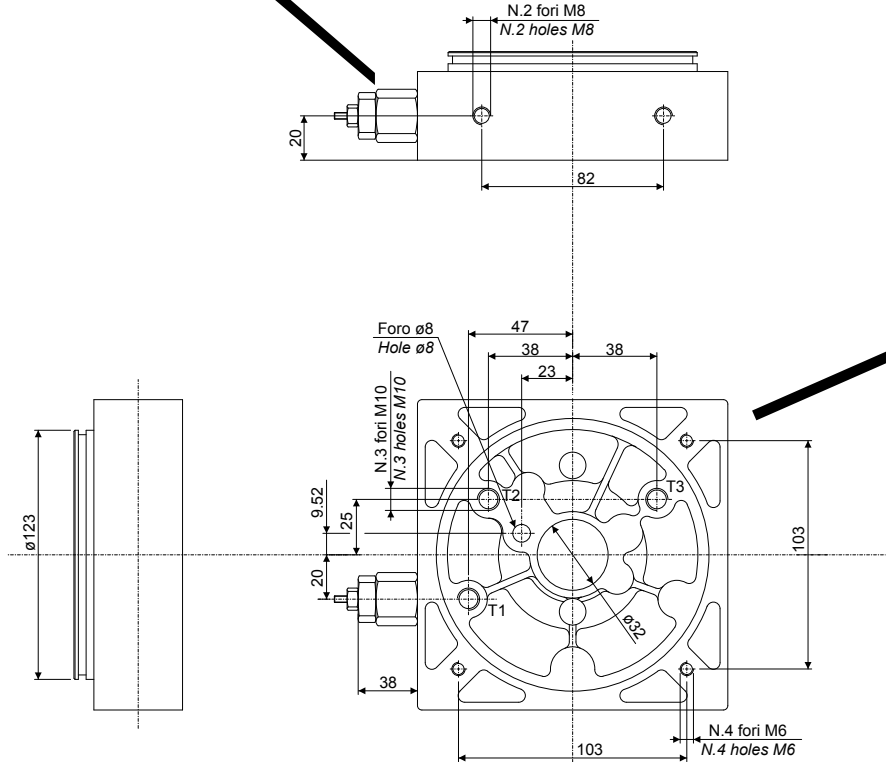
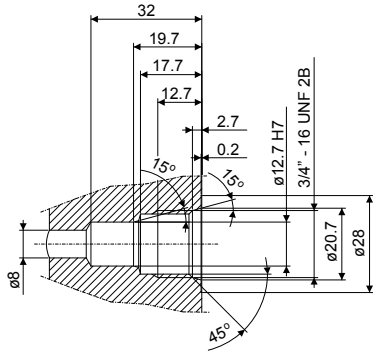

Rif. "C"

Predisposizione per attacchi blocco "CETOP 3"
 Arranged for "CETOP 3 elements"

N	Non sono presenti fori di fissaggio Without fixing holes
S	Sono presenti N. 2 fori M8 With N. 2 fixing holes

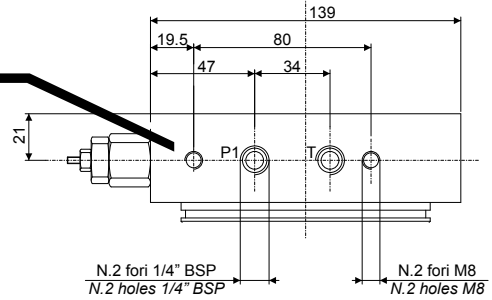

Codice di ordinazione blocco centrale
How to order the central manifold

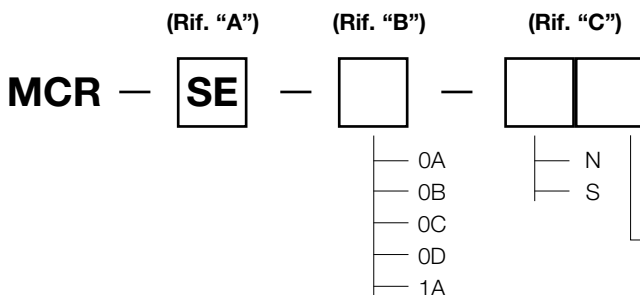

Predisposizione blocco per motori
Central manifold arranged for motors

- 1 Motori in C.C. (vedi pag. 04) / D.C. motors (see pag. 04)
- 2 Motori in C.A. Tg. 63, 71 / A.C. motors Size 63, 71
- 3 Motori in C.A. Tg. 80, 90, 100 - 112
A.C. motors size 80, 90, 100 - 112
- 4 Tutti i motori in C.C. e C.A. Tg. 63, 71, 80, 90, 100, 112
All D.C. and C.A. motors Size 63, 71, 80, 90, 100, 112

Rif. "B"

Blocchi predisposti per pompe a rotazione sinistra / Central manifold arranged for anticlockwise rotation pumps

Foratura per pompe gr. 1
 Drilling for pumps gr. 1

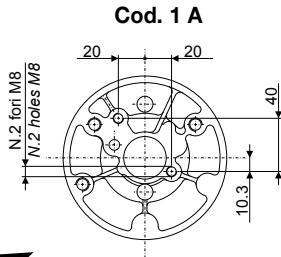

Forature per pompe gruppo 0,5 / Drilling for pumps group 0.5

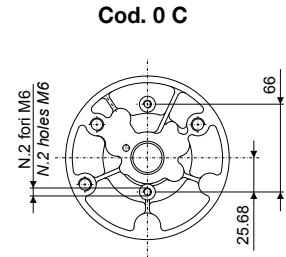
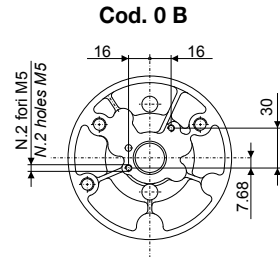
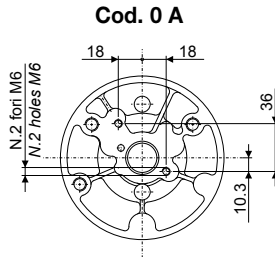

Cod. 0 D: Comprende tutte le forature del gruppo 0,5 / Including all group 0.5 drillings

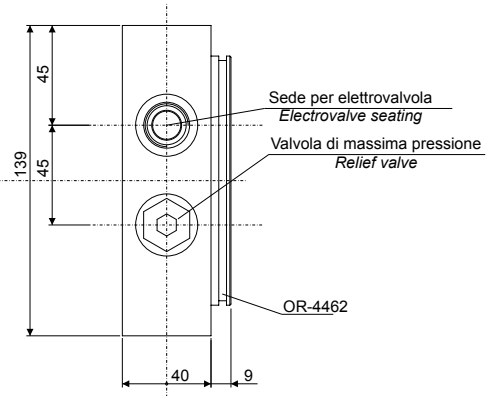
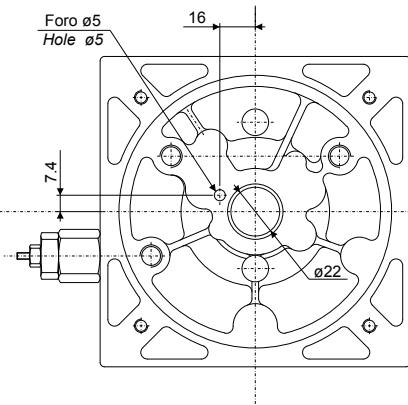

Rif. "A"

Semplice effetto
 Simple effect

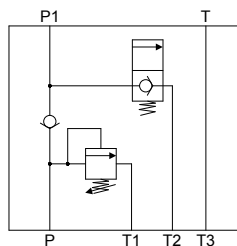

Esempio codice completo
Complete part number example

MCR — SE — 1A — N4

- Il blocco centrale viene fornito con la valvola di ritegno (MCR-VR14) e la guarnizione per il serbatoio (OR-4462).
- La valvola di max. va ordinata separatamente. (vedi pag. 44)
- OMT Group non fornisce l'elettrovalvola.

- The central manifold is always supplied with chek valve (MCR-VR14) and the tank gasket (OR-4462).
- To order the relief valve on pressure port and the hand pump. (see pag. 44)
- OMT Group doesn't supply electrovalves.



BLOCCO CENTRALE "DOPPIO EFFETTO"
CENTRAL MANIFOLD "DOUBLE EFFECT"

Codice valvola di massima Relief valve part-number	Taratura Setting
MCR-V1-F	10-70 Bar
MCR-V2-F	35-140 Bar

Sede valida per valvola di massima e pompa a mano
 Seating for relief valve and electric valve

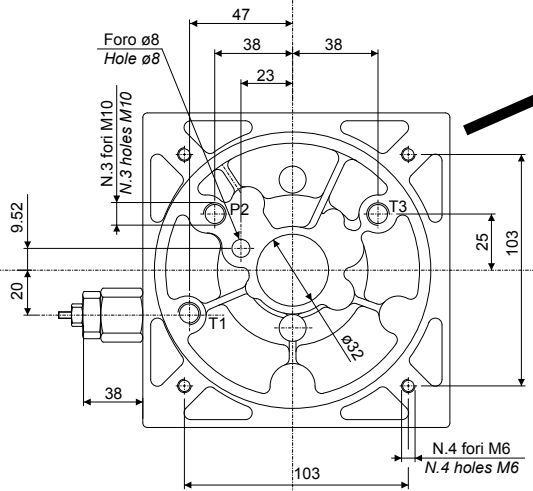
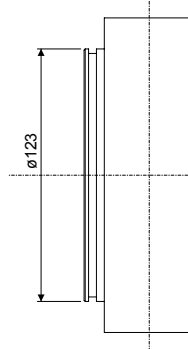
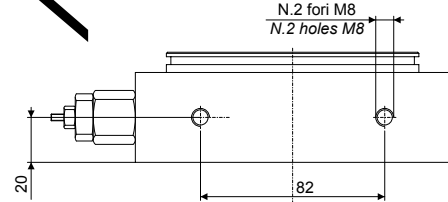
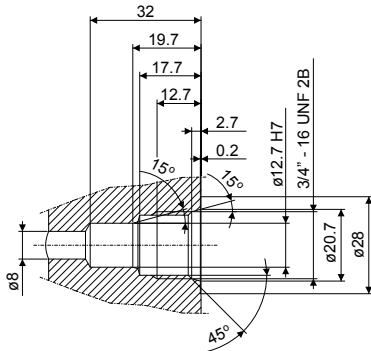

Rif. "C"

Predisposizione per attacchi blocco "CETOP 3"
 Arranged for "CETOP 3 elements"

N	Non sono presenti fori di fissaggio Without fixing holes
S	Sono presenti N. 2 fori M8 With N. 2 fixing holes

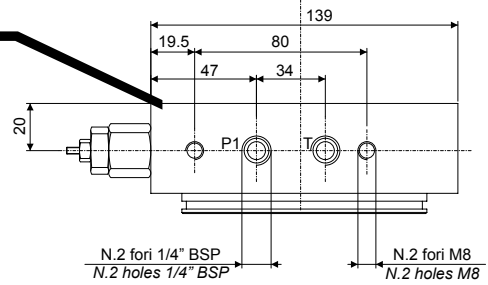

Codice di ordinazione blocco centrale
How to order the central manifold

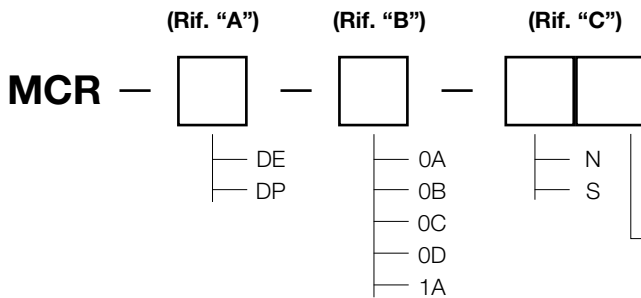

Predisposizione blocco per motori
Central manifold arranged for motors

- 1 Motori in C.C. (vedi pag. 04) / D.C. motors (see pag. 04)
- 2 Motori in C.A. Tg. 63, 71 / A.C. motors Size 63, 71
- 3 Motori in C.A. Tg. 80, 90, 100 - 112
A.C. motors size 80, 90, 100 - 112
- 4 Tutti i motori in C.C. e C.A. Tg. 63, 71, 80, 90, 100, 112
All D.C. and C.A. motors Size 63, 71, 80, 90, 100, 112

Rif. "B"

Blocchi predisposti per pompe a rotazione sinistra / Central manifold arranged for anticlockwise rotation pumps

**Foratura per pompe gr. 1
 Drilling for pumps gr. 1**

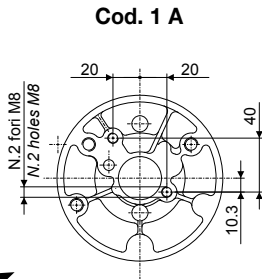

Forature per pompe gruppo 0,5 / Drilling for pumps group 0.5

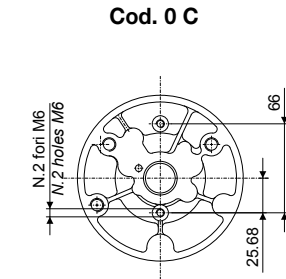
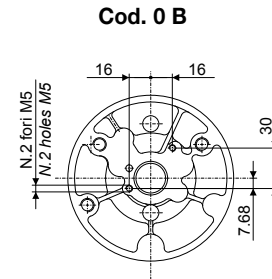
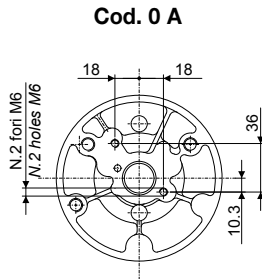

Cod. 0 D: Comprende tutte le forature del gruppo 0,5 / Including all group 0.5 drillings

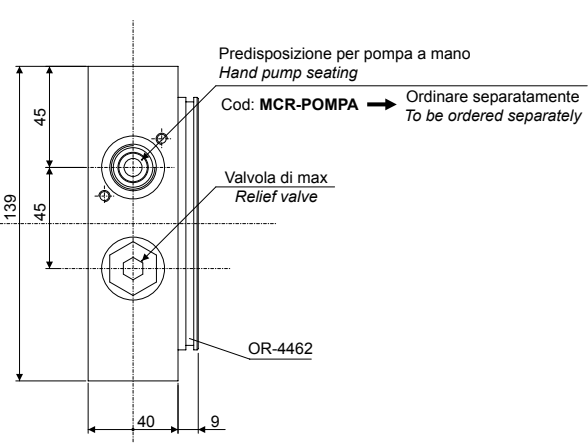
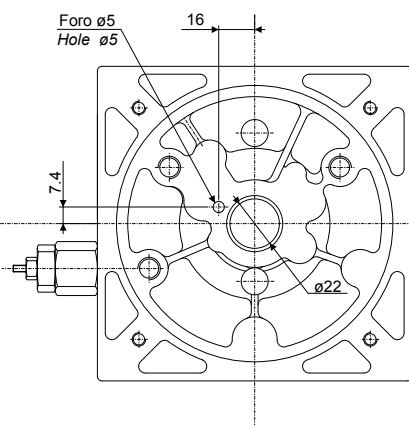

Rif. "A"

Schemi funzionali versione doppio effetto (DE), a doppio effetto con predisposizione per pompa a mano (DP)
Functional layout double effect version and double effect arranged for hand pump

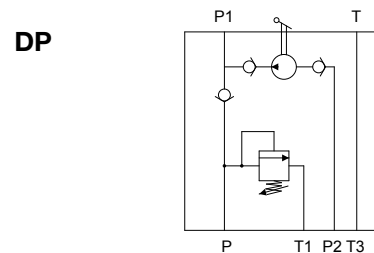
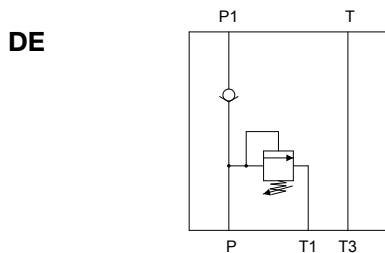

**Esempio codice completo
 Complete part number example**

MCR — DE — 0B — S1



- Il blocco centrale viene fornito con la valvola di ritegno (MCR-VR14) e la guarnizione per il serbatoio (OR-4462).
- La valvola di max. e la pompa a mano vanno ordinati separatamente. (vedi pag. 46)

- The central manifold is always supplied with chek valve (MCR-VR14) and the tank gasket (OR-4462).
- To order the relief valve on pressure port and the hand pump. (see pag. 46)

Disegno / Drawing

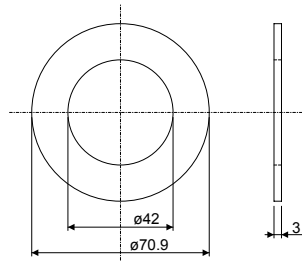

Codice / Code

MCR-ANELLO-CC

FLANGE DI ADATTAMENTO PER MOTORI C.A.
ADAPTER FLANGERS FOR A.C. MOTORS

Taglia motore / Motor size	Disegno / Drawing	Codice / Part number	Viti / Screws*
63		MCR-LANT-63	M6 X 20 UNI5931 + rosetta elastica A 6,4 UNI1751
71		MCR-LANT-71	M6 X 20 UNI5931 + spring washer A 6,4 UNI1751
80		MCR-LANT-80	
90		MCR-LANT-90	M6 X 30 UNI5931 + rosetta elastica A 6,4 UNI1751 M6 X 30 UNI5931 + spring washer A 6,4 UNI1751
100-112		MCR-LANT-100	

* Per il fissaggio delle flange al blocco centrale utilizzare le viti sopraindicate / To fix the flanges to central manifold use the above indicated screws.

Taglia motore Motor size	Grandezza pompa Pump size	Disegno / Drawing	Codice / Part number
63	gr. 0		MCR-SG11-P0
71	gr. 0		MCR-SG14-P0
80	gr. 0		MCR-SG19-P0
71	gr. 1		MCR-SG14-P1
80	gr. 1		MCR-SG19-P1
90	gr. 1		MCR-SG24-P1
100-112	gr. 1		MCR-SG28-P1

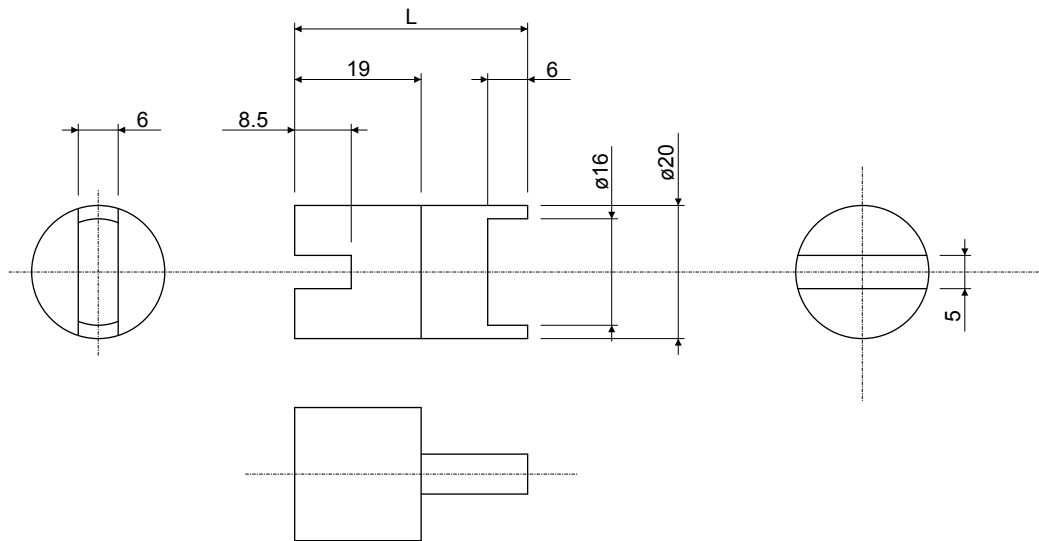
Motori ISKRA in C.C. ø80
ISKRA DC Motors ø80

Motore Motor	Pompa Pump	L	Codice Part number
ø80 (0.15-0.5-0.8 KW) 12/24 V	gr. 0	35	MCR-SG0-CC08
ø80 (0.15-0.5-0.8 KW) 12/24 V	gr. 1	35	MCR-SG1-CC08

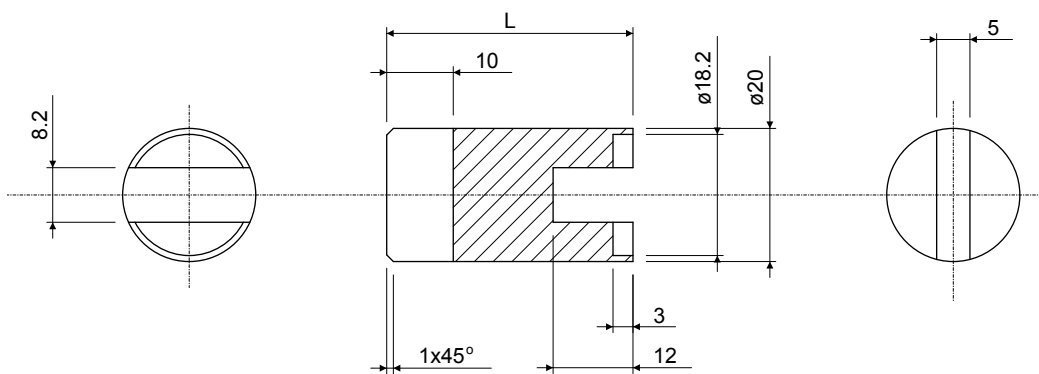
Motori ISKRA in C.C. ø114
ISKRA DC Motors ø114

Motore Motor	Pompa Pump	L	Codice Part number
ø114 (1.6-2.2 KW) 12/24 V	gr. 0	37	MCR-SG0-CC37
ø114 (1.6-2.2 KW) 12/24 V	gr. 1	35	MCR-SG1-CC35

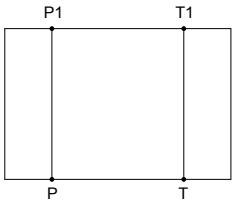
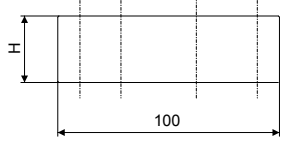
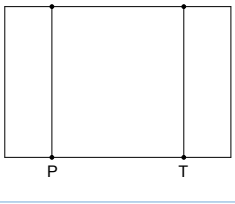
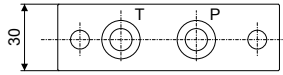
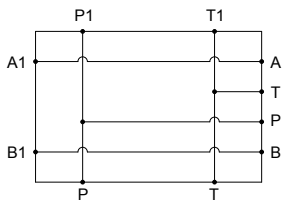
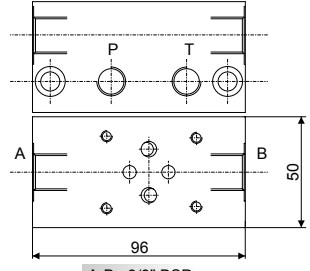
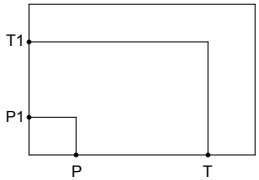
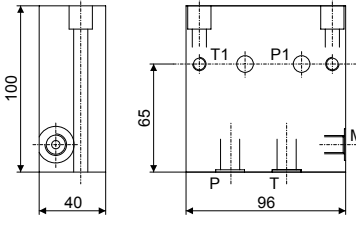
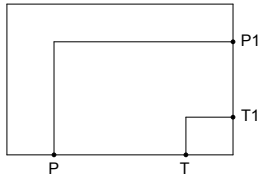
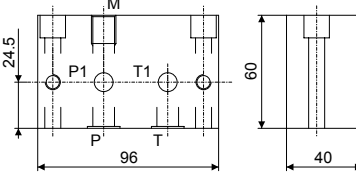
Codice Part number	Schema Diagram	Descrizione Description	Disegno Drawing
MCR-DIS-30		Piastra distanziale H = 30 mm Spacing element H = 30 mm	
MCR-DIS-50		Piastra distanziale H = 50 mm Spacing element H = 50 mm	
MCR-OIL-03		Piastra per elettrovalvola CETOP 03 (luce 6) collegamento in parallelo Element for solenoid valves CETOP 03 parallel connection	 <p>A-B : 3/8" BSP</p>
MCR-OIL-07		Piastra per rotazione figura orizzontale lato motore Element for horizontal modular system-motor side	
MCR-OIL-08		Piastra per rotazione figura orizzontale lato serbatoio Element for horizontal modular system-tank side	

SERBATOI TONDI
OIL TANKSSER —  — (RAC)Capacità nominale
in Litri
Nominal capacity
in Liters

1.5
2.5
5
8
10
12

Indicare "RAC" solo se si desidera la fornitura del serbatoio con il raccordo "SC-RAC" per il montaggio con il raccordo.
Kindly indicate "RAC" in the part-number if wish the supply of the oil tank with the elbow joint "SC-RAC" for the vertical assembling

SER-12	Serbatoio senza raccordo Oil tank without elbow joint
SER-12-RAC	Serbatoio fornito di raccordo per il montaggio in verticale Oil tank with elbow joint

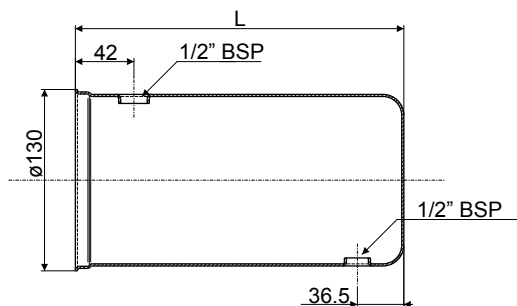

Codice Part number	L
SER-1.5	150
SER-2.5	235

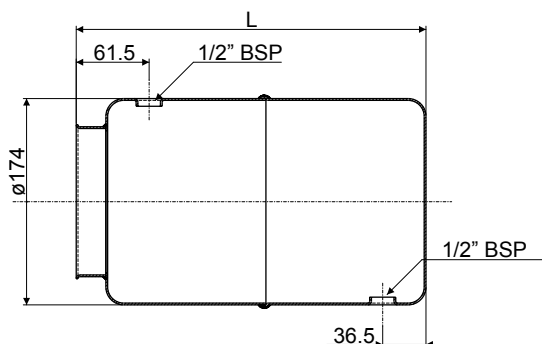

Codice Part number	L
SER-5	295
SER-8	419

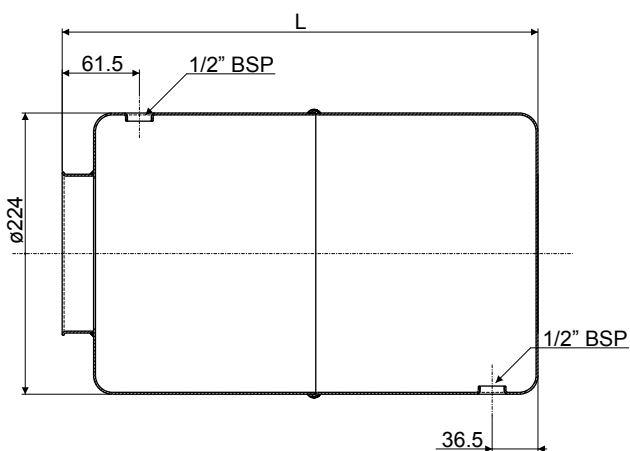

Codice Part number	L
SER-10	262
SER-12	380

Per il montaggio in verticale:
For vertical assembling

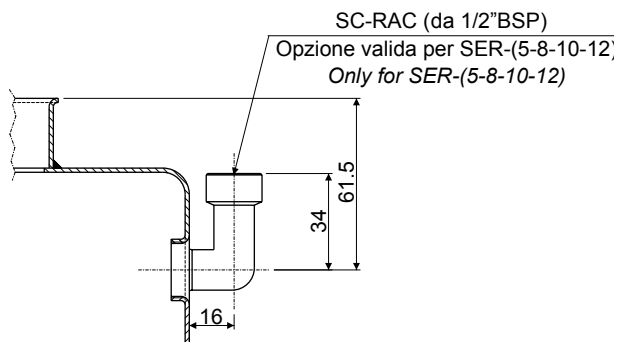

SERBATOI IN ALLUMINIO E SERBATOI RETTANGOLARI ALUMINIUM OIL TANKS AND RECTANGULAR OIL TANKS

Serbatoi in alluminio serie CP Aluminium oil tanks, CP series

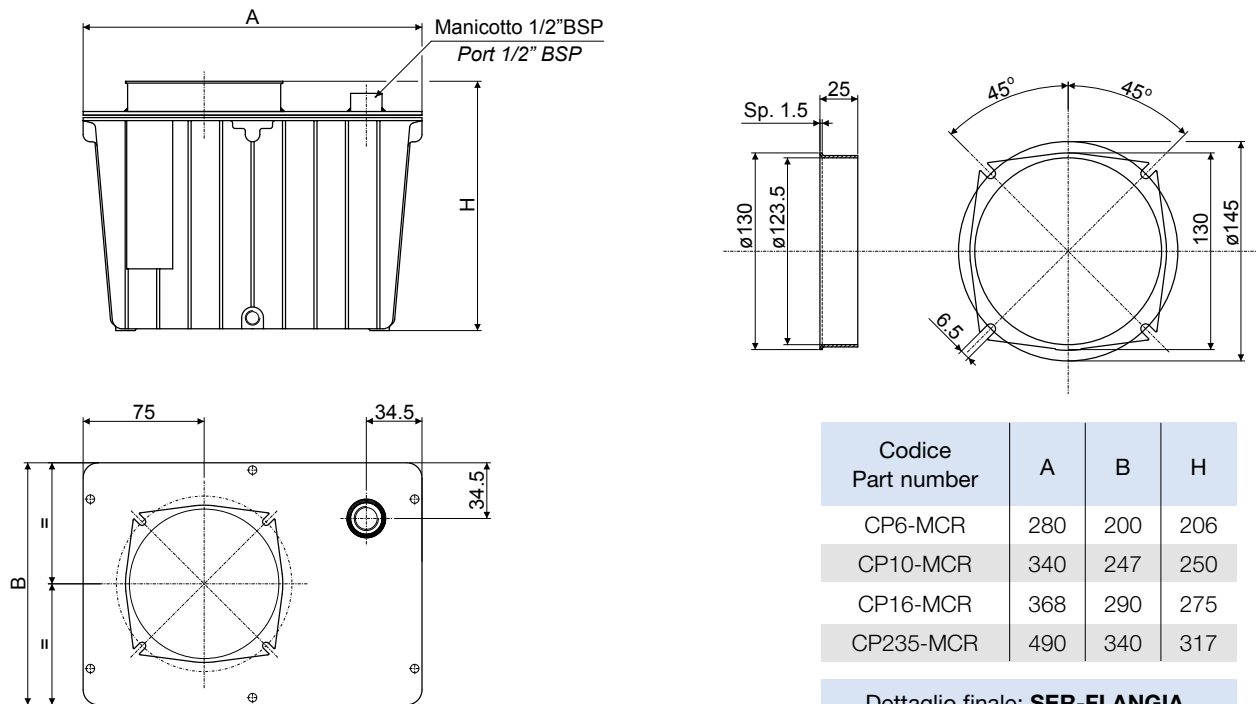

Codice Part number	A	B	H
CP6-MCR	280	200	206
CP10-MCR	340	247	250
CP16-MCR	368	290	275
CP235-MCR	490	340	317

Dettaglio finale: **SER-FLANGIA**
Flange detail: **SER-FLANGIA**

Serbatoi rettangolari serie SL Rectangular oil tanks, SL series

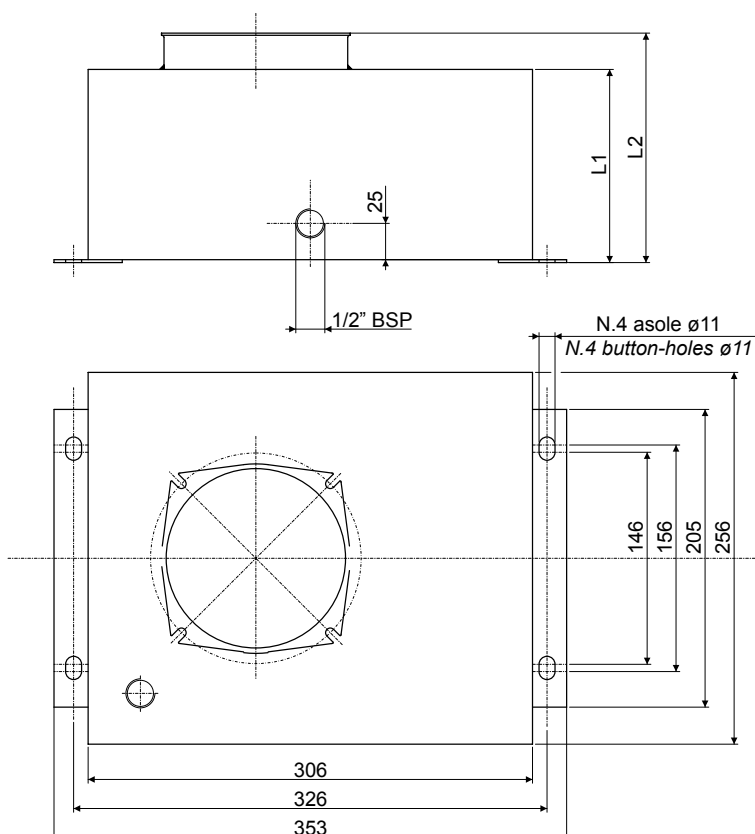

Codice Part number	L1	L2	Capacità nominale (Litri) Nominal capacity (Liters)
SL-08	133	158	8
SL-15	237	268	15
SL-20	306	331	20

Per il fissaggio di tutti i serbatoi al blocco centrale utilizzare viti M6x12 UNI 5739 + rosetta elastica A 6,4 UNI 1751

To fix all oil tanks to central manifold use M6x12 UNI 5739 screws + spring washer A 6.4 UNI 1751

Filtro olio idraulico in aspirazione Hydraulic oil suction filter

Codice Part number	øA	B	E	G	Area filtrante Filtration area (cm ²)	Materiale Material	Grado di filtrazione Filtration Ratio (micron)	Portata Flow (l/min)
MCRFR503546	63	16	6	1/4" BSP	30	Reps. Fe Zn	250	9
MCRFR103570	63	18	8	3/8" BSP	30	Lam. INOX	250	12
MCRFR502395	80	23	5	1/4" BSP	200	Reps Fe Zn	90	12
MCRFR102392	80	25	7	3/8" BSP	200	Reps Fe Zn	90	14

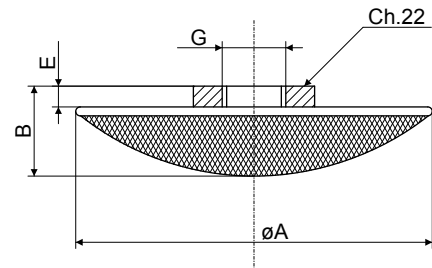

Filtro olio idraulico in aspirazione 1/4" GAS Hydraulic oil suction filter 1/4" gas

Codice Part number	øA	B	E	Area filtrante Filtration area (cm ²)	Materiale Material	Grado di filtrazione Filtration Ratio (micron)	Portata Flow (l/min)
MCRFR501759	32	27	6	34	Reps. Fe Zn	90	5

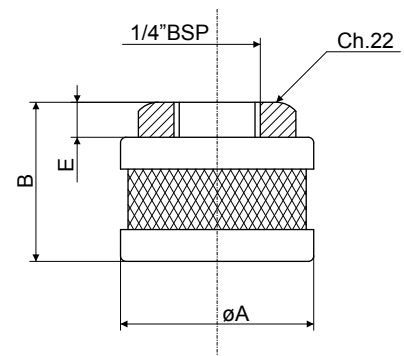

STAFFA FOOT FLANGE

MCR - Staffa

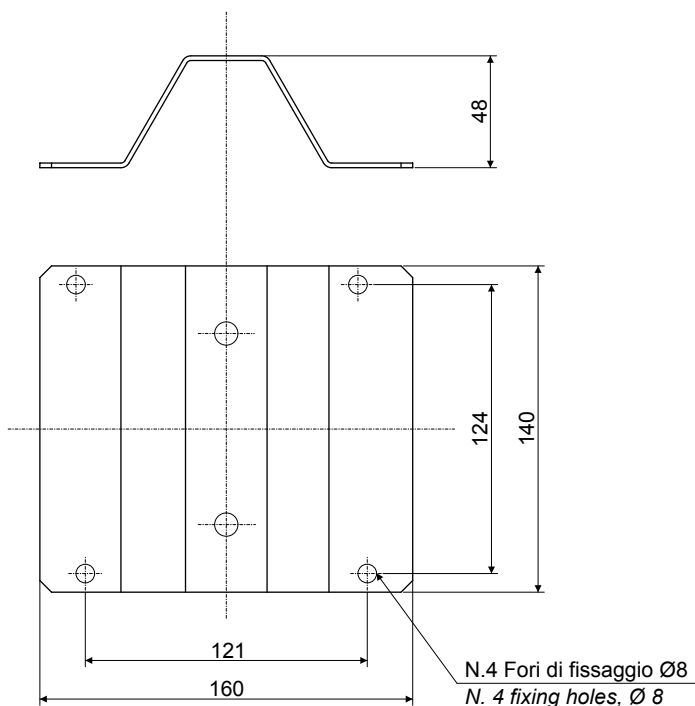

Per il fissaggio della staffa al blocco centrale utilizzare viti M8 x 12 UNI5739 rosetta elastica A 8,4 UNI1751.

To fix foot flange to central manifold use M8 x 12 UNI5739 screws + spring washer A 8,4 UNI1751

BC20 MICROCENTRALINE BC20 MICRO POWER UNITS

PRESENTAZIONE

I componenti per minicentraline OMT Group sono studiati per permettere all'utilizzatore di realizzare in breve tempo un gruppo idraulico compatto, semplice ed affidabile. Con essi è possibile accoppiare pompe ed ingranaggi standard del gruppo 0,5-1 con motori C.A. tipo UNEL-MEC - forma B5 - gruppo 80 e 90 (potenza da 0,55 a 1.5 kW); e motori C.C. da 12V e 24V. Per richiesta motore C.C. 12/24 V preghiamo interpellare il nostro ufficio tecnico.

INTRODUCTION

Studied to allow an easy assembly of a small size power unit when using standard gear pumps group 0.5 or 1 with AC electric motors (Unel-Mec, B5 form, type 80 and 90; 0.55 to 1.5 kW) or DC 12/24 Volts up to 3 kW.

Please contact our commercial department for D.C. 12/24.

DIMENSIONI / DIMENSIONS

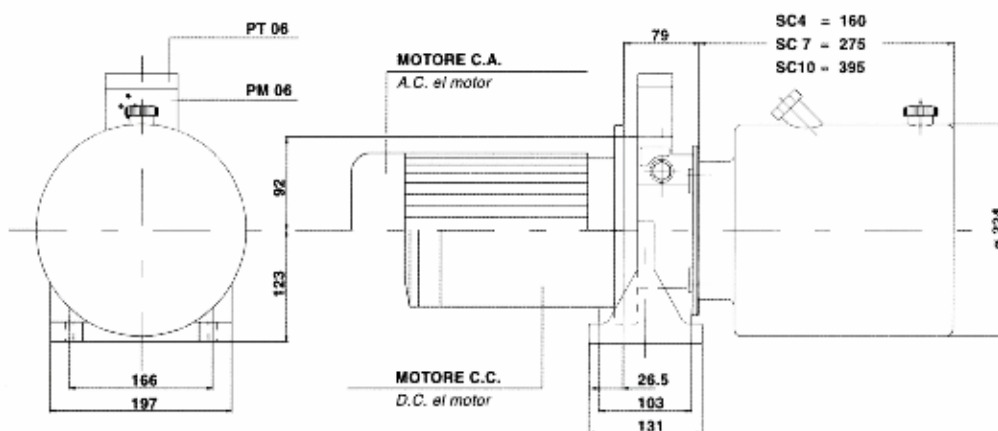

DESCRIZIONE / DESCRIPTION

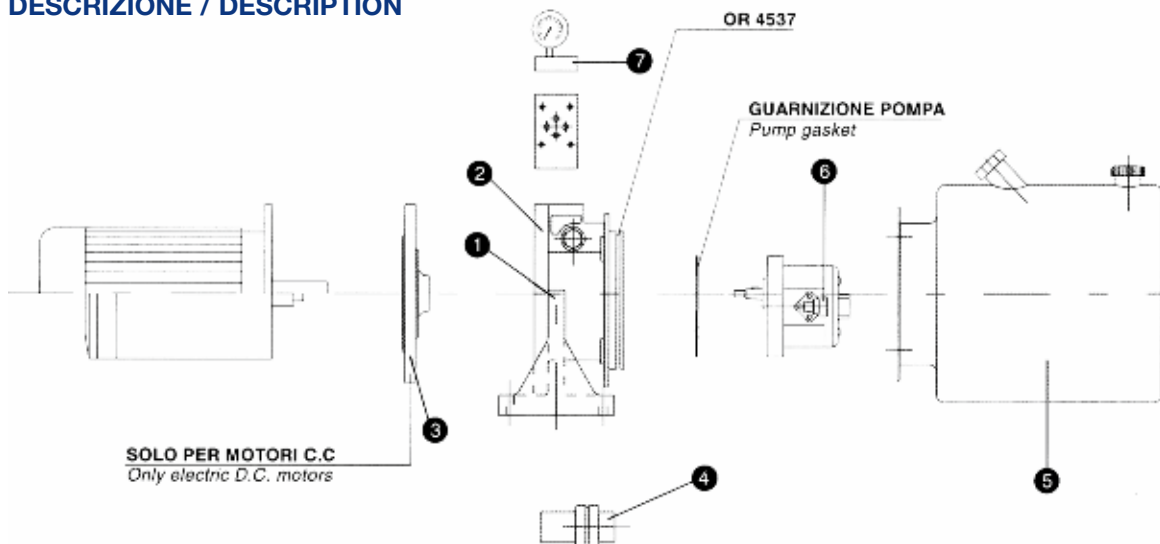

Posizione / Item no.	Descrizione / Description	Codice / Code
1	Supporto gruppo - Foot flange	P 200
2	Lanterna BC 20 - Bell-housing	BC 20...
3	Flangia connessione motore el. C.C. 12V & 24V Special flange for mounting of D.C. electric motor	FBC 20 - F1BC20
4	Giunto di trasmissione - Coupling	ND... - NDBC
5	Serbatoio olio - Oil tank	SC
6	Accessori pompa - Pump accessories	vedere punti 6 e 7 pagg. successive see items 6 and 7 next pages
7	Piastre componibili - Manifold	

1) Supporto gruppo tipo P200 / Foot flange type P200

Costruito in lega di alluminio ad elevata resistenza meccanica. Adatto quale supporto del gruppo motore / pompa nel caso usiate motori elettrici senza piedini.

Electric motor foot flange series made of high quality aluminium alloy. Suitable for use as a support for the motor unit/pump if you use electric motors without legs.

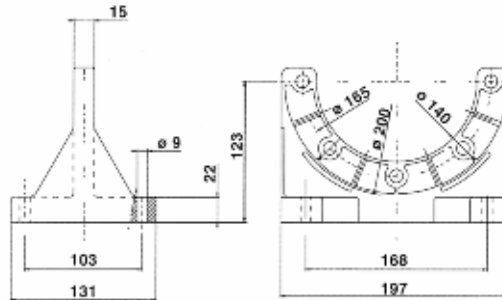

2) Lanterna tipo BC20 - Bell housing type BC20

Costruita in lega d'alluminio di elevata resistenza meccanica, è predisposta per incorporare la valvola di massima pressione regolabile e quella di non ritorno. Consente il montaggio di vari tipi di pompe ad ingranaggi gruppo 0,5 e 1. Il fissaggio dei motori C.A. Gruppo 80-90 forma B5 avviene direttamente al corpo, con flangia di adattamento per motori C.C. 12V e 24V. La lanterna BC20 viene fornita del OR 4537 di tenuta fra corpo e serbatoio e della guarnizione (in guarnital) di tenuta fra corpo e pompa ad ingranaggi.

Made with high quality Aluminium alloy it permits to mount standard group 0,5 or 1 pumps with AC electric motors (Unel-Mec standard, B5 form, type 80 and 90; 0,55 to 1,5 Kw) or DC 12/24 Volts up to 3 Kw. On customer request we can supply DC electric motors. It can be supplied fully machined with built-in adjustable relief valve and check valve on pressure port. It is always supplied complete of o-ring seal between BC 20 and oil tank, and of a gasket sealing BC 20 and gear pump.

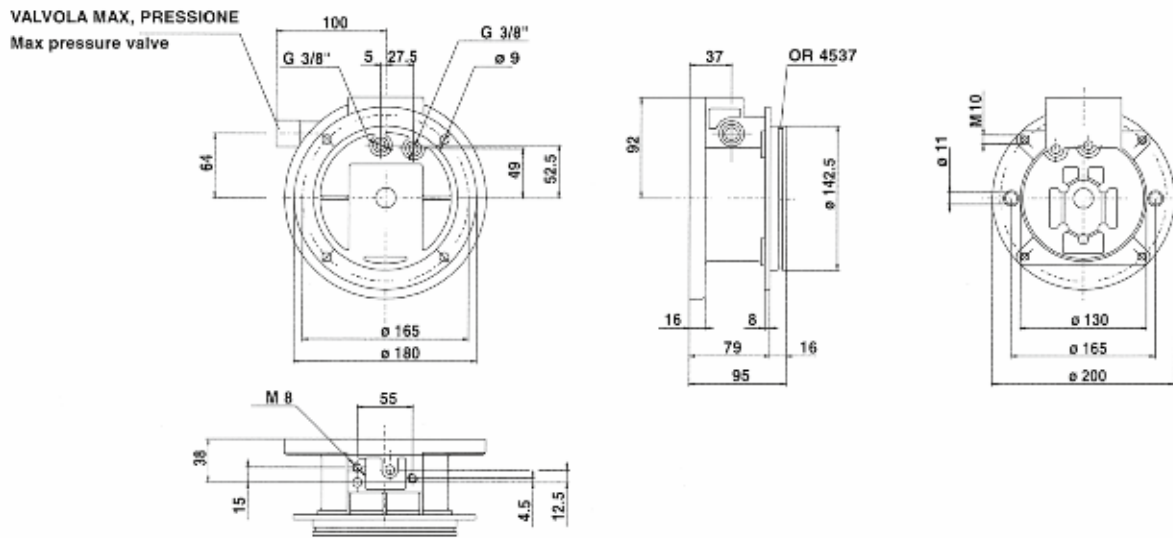

Codice per l'ordinazione - How to order

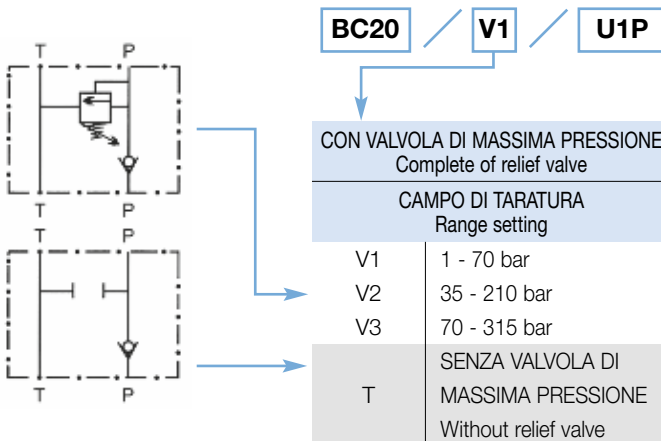

CODICE POMPA PUMP TYPE	LAVORAZ. LATO POMPA - PUMP SIZE				
	E	L	M	N	O
U 05	22	25,5	66	-	
U 1P	25,4	26,2	72	52	M 6
CM 1	30	24,5	73	56	
ZBR	32	10,3	40	40	M 8

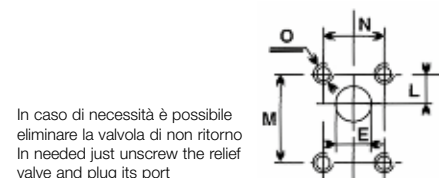

3) Flangia connessione motore elettrico C.C. 12V & 24V tipo F1BC20 - FBC20 Flange for connection of D.C. 12V/24V electric motor to BC20

Costruita in lega d'alluminio ad alta resistenza, incorpora la boccia in bronzo autolubrificante per il supporto dell'albero motore.

Made of high resistance. Al alloy has a built in bearing supporting the electric motor shaft.

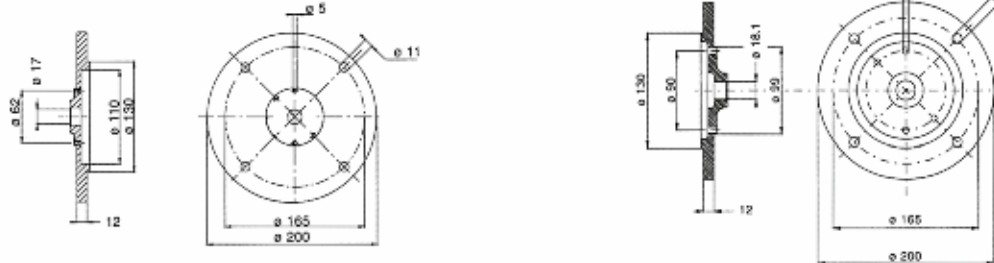

PER MOTORI "EFEL" C.C. 36501/36511 O EQUIVALENTI
For "EFEL" motors D.C. EL.36501/36511 or same

F1BC20

PER MOTORI "EFEL" 36884/36892 O EQUIVALENTI
For "EFEL" motors D.C. EL.36884/36892 or same

FBC20

4) Giunto di connessione tipo ND48 / Elastic coupling type ND48

Realizzati in alluminio ad elevata resistenza meccanica. Trovano immediata applicazione quali organi di trasmissione quando è già stata fatta la prima scelta della pompa e del motore.

Elastic couplings made of Al alloy having high mechanical resistance.

Caratteristiche dei giunti ND sono: inserto elastico (trascinatore) realizzato in gomma anti olio ottenendo massima silenziosità di esercizio, buon isolamento elettrico.

Feature, of ND couplings, are:
very low noise-level, good electrical insulation.

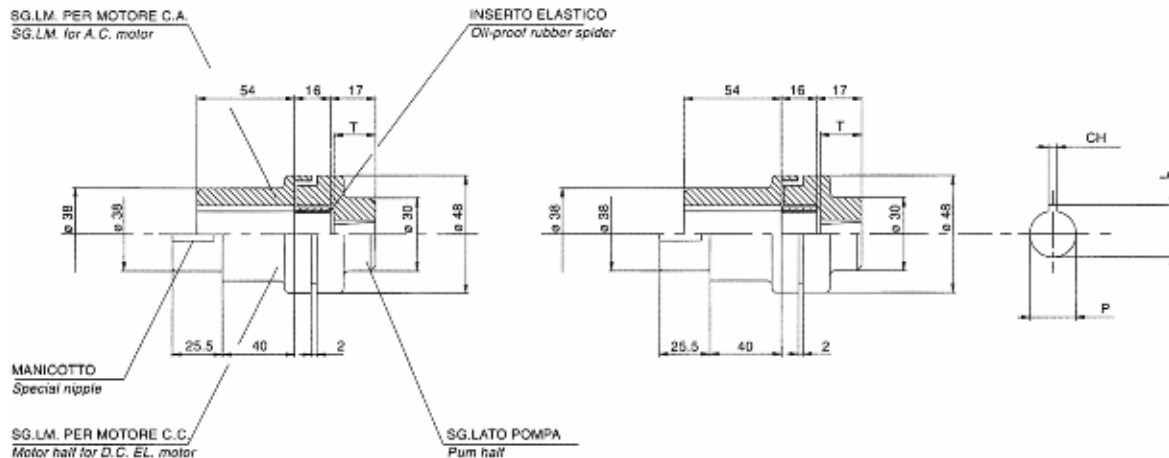

PER MOTORI "EFEL" C.C. 36501/36511 O EQUIVALENTI
For "EFEL" motors D.C. EL.36501/36511 or same

PER MOTORI "EFEL" 36884/36892 O EQUIVALENTI
For "EFEL" motors D.C. EL.36884/36892 or same

Tabella ricerca codice giunto - Table how to order the coupling

Motore C.A. - AC. EL motor UNEL - MEC B5		Motore C.C. 12-24V Tipo 36501-36511	Motore C.C. 12-24V Tipo 36894-36892	Pompa Pump	Lavorazione lato pompa Pump side				
GR. 80	GR. 90				Capacità Taper	P	CH	L	T
Albero - Shaft ø 19x40		*Vedere nota *see nota	*Vedere nota *see nota						
N 4 D	-	ND1 BC4	ND BC4	0,5 M	-	6	2	7	10
ND 4 A	-	ND1 BC4 A	ND BC4 A	0,5 GT	-	7	2	8	10
ND 5	ND 70 A	ND1 BC5	ND BC5	U 1P	1:8	9,7	2,4	10,5	14
ND 6	ND 70 B	ND1 BC6	ND BC6	1 C	-	12	3	13,3	13,5
ND 6 A	ND 70 C	ND1 BC6 A	ND BC6 A	1 M	1:8	13,9	3	15,5	18,5
ND 200	ND 70 D	ND1 BC 200	ND BC 200	ZBR	1:5	9,8	2	10,2	12

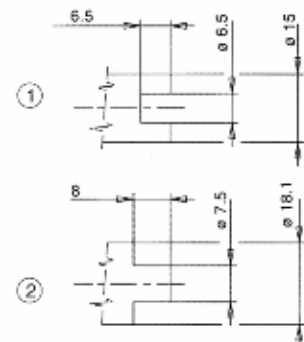

* Con motore C.C. il giunto è fornito di un manicotto in acciaio per l'adattamento del giunto all'albero motore.
When using a D.C. el motor we supply a special nipple to adapt ND couplings to D.C. motor shaft form

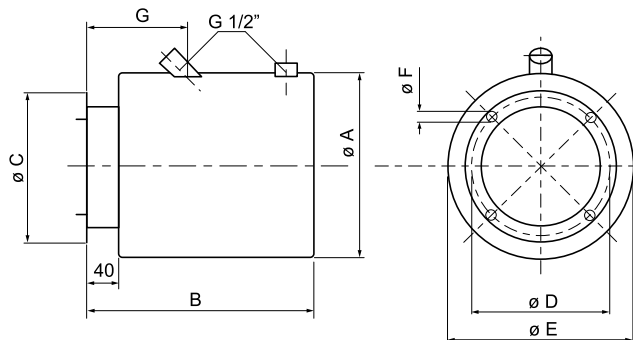
5) Serbatoi tipo SC
Oil tank type SC

TIPO TYPE	Capacità utile Lt Useful capacity Lt.	Dimensioni - Sizes						
		A	B	C	D	E	F	G
SC4 - 224	4		160					-
SC7 - 224	7	224	275	179	143	165	9	107
SC10 - 224	10		395					107

6) Accessori pompa: Raccordi tipo RP
Pump accessories: Elbow joint type RP

Costruita in lega di Al indurita termicamente sono adatti per il montaggio su pompe oleodinamiche.
 Pressione max di esercizio 600.
 Vengono forniti completi di viti ed o-ring (vedi tabella) e rondelle Grower.

Elbow joints series made of tempered Al alloy, suitable to be mounted on hydraulic oil pumps.
 Max. working pressure: 600 bar.
 They're supplied complete with screws, O-ring (see table) and Grower washer.

VEDI CATALOGO GENERALE RACCORDI - SEZIONE 02
SEE GENERAL CATALOGUE RACCORDI - SECTION 02

Filtri SF - F01 / Filters

Filtri specifici per questo utilizzo. In aspirazione **SF 46A-G0**.
 Grado di filtrazione 125 μ m. Portata massima 15 l/min.
 Sul ritorno **F01**.
 Grado di filtrazione 20 μ m. Portata massima 20 l/min.
 Incorpora la valvola di by-pass

"SF" and "F01" filters. Suction and return filters specially designed for this application. Filtration on suction type SF is 125 micron and flow up to 15 l/min.
 On return the type F01 has flow up to 20 l/min and optional filtration 20 micron F01 filter has built in by-pass valve.

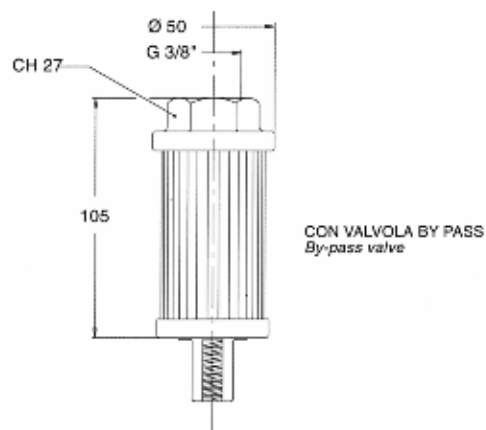
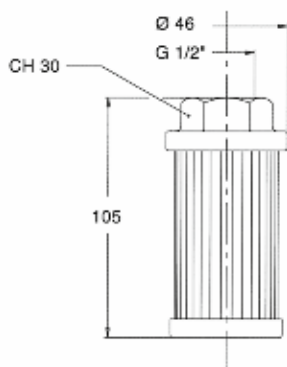

7) Piastre componibili per valvole attacco CETOP 3 Manifold 7 or mounting of CETOP 3 (NG6) solenoid valves

Simboli / Symbols

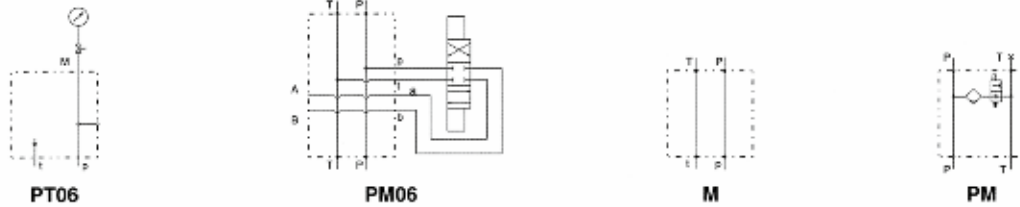

Piastra tipo PT06 / Plate type PT06

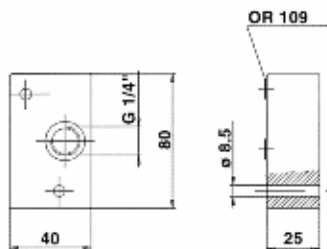

Descrizione / Description

Piastra di chiusura predisposta per attacco manometro.

"Blind" flange including a manometer port

Piastra tipo PM06-F / Plate type PM06-F

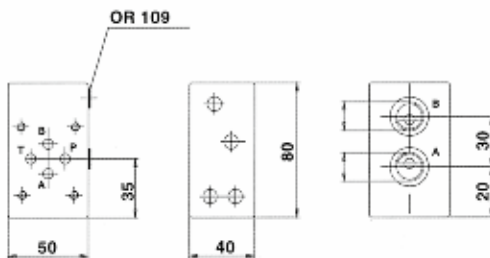

Piastra di connessione per elettrovalvola norme CETOP 3

Manifold for mounting of CETOP 3 (NG 6) solenoid valves.

Piastra tipo M / Plate type M

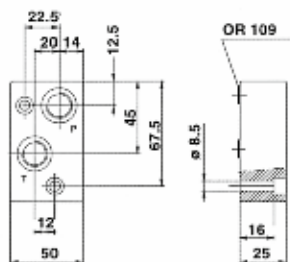

Piastra per attacco diretto nel caso di regolazione a distanza

Manifold for remote control (it allows to mount the valve block separately from the power unit)

Piastra tipo PM / Plate type PM

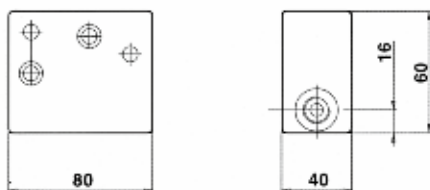

Piastra di connessione per attacco elettrovalvola

Connexion plate for electro-valve for mounting and manual control