



OIL SOLUTIONS

PO Box 38  
Strathfieldsaye, VIC, 3551  
1800 OIL SOL  
1800 645 765  
[sales@oilsolutions.com.au](mailto:sales@oilsolutions.com.au)  
[www.oilsolutions.com.au](http://www.oilsolutions.com.au)  
"For All Your Hydraulic Needs"



Trust it

LANTERNE  
PER POMPE INGRANAGGI

BELLHOUSINGS  
FOR GEAR PUMPS

Le lanterne monoblocco della serie LS - LSE - L - LE per pompe ad ingranaggi sono utilizzate come organi di collegamento tra motore elettrico Unel-Mec forma B3 - B5 - B14 e pompe ad ingranaggi a flangia rettangolare. Disponibili con o senza anello di estrazione giunto. Realizzate in pressofusione di alluminio possono essere utilizzate per montaggi esterni o in immersione in olio.

The LS - LSE - L - LE series monobloc bellhousings for gear pumps are used as connecting between Unel-Mec electrical motors with standards B3 - B5 - B14 and gear pumps with rectangular flange. Available with or without centering ring for the extraction of the coupling. Made in die-cast aluminum, they can be used for external mounting or for oil immersion applications.





## Pompa oleodinamica

I giunti di accoppiamento sono utilizzati quali elementi di collegamento tra motore elettrico a flangia unificata e pompa oleodinamica per la trasmissione del moto. I giunti di questa gamma consentono un assemblaggio ottimale tra motori elettrici a flangia unificata fino a 315 kW.

**SEMIGIUNTI** serie **ND**  
realizzati in alluminio con preforo minimo di fusione (elastici)

**SEMIGIUNTI** serie **NS**  
realizzati in alluminio con mozzo chiuso (elastici)

**SEMIGIUNTI** serie **NDG**  
realizzati in ghisa sferoidale con mozzo chiuso (elastici)

**SEMIGIUNTI** serie **OMT**  
realizzati in acciaio con mozzo sia lavorato che chiuso

I semigiunti vengono ricavati dal chiuso nei seguenti casi:

1. La lunghezza del semigiunto ND non è sufficiente a realizzare l'accoppiamento.
2. Il preforo di fusione è troppo grande rispetto al foro da realizzare per il calettaggio sulla pompa.
3. Il mozzo è troppo piccolo per poter realizzare la foratura per il calettaggio sulla pompa.

### Dati indispensabili per la scelta del semigiunto

1. Potenza del motore (tab. motori vedi pag. 17).
2. Caratteristiche dimensionali della pompa oleodinamica.

### MATERIALI

<b>Semigiunti serie</b>	
- <b>NS/ND</b>	Lega di alluminio per pressofusione e conchiglia
- <b>NDG</b>	Ghisa sferoidale
- <b>OMT</b>	Acciaio
<b>Inserito elastico per</b>	
- <b>ND</b>	Miscela di acril nitrile butadiene durezza 75 Shore ±5% nera
- <b>NDG 86/108/143</b>	Miscela di acril nitrile butadiene durezza 92 Shore ±5% rossa
- <b>NDG 160/200</b>	Poliuretano 90 Shore ±5% nero

**Manicotto per**  
- **OMT** Poliammide 6.6

**Temp. di esercizio** -15°C +100°C

### COMPATIBILITÀ CON I FLUIDI

Tutte le parti che vengono esposte all'ambiente marino devono essere protette con trattamenti superficiali oppure con vernici adeguate all'impiego e comunque da specificare in fase di ordinazione del materiale all'ufficio commerciale.

### APPLICAZIONI SPECIALI

Per tutte le applicazioni che non rientrano nei casi normali specificati in questo catalogo contattare l'ufficio commerciale della OMT S.p.A. per un eventuale studio di fattibilità.

## Hydraulic pump

The couplings are used to establish a connection between an electrical motor with standard flange and a pump. The bellhousings of this range allow to establish a perfect assembly between electrical motors with standard flange up to 315 kW and the majority of the hydraulic pumps available on the world market.

**HALF COUPLINGS** series **ND**  
in aluminium, with precast minimal boring (elastic type)

**HALF COUPLINGS** series **NS**  
in aluminium, blank (elastic type)

**HALF COUPLINGS** series **NDG**  
in spheroid iron, blank (elastic type)

**HALF COUPLINGS** series **OMT**  
in steel, available blank or with machined front

In the following cases the halfcouplings are machined from blank raw parts:

1. The length of the ND type halfcoupling is not sufficient to realize the required complete coupling
2. The diameter of the precast minimal boring is too big to allow correct fixation on the pump shaft
3. The diameter of the head is too small to allow the realization of the required pump side boring.

### Necessary indications for the correct choice of a halfcoupling

1. Power of the motor (tab. motors see pag. 17).
2. Dimensional data of the hydraulic pump.

### MATERIALS

<b>Halfcouplings series</b>	
- <b>NS/ND</b>	Aluminium alloy for die-and shell-casting
- <b>NDG</b>	Spheroid cast iron
- <b>OMT</b>	Steel
<b>Rubber spider</b>	
- <b>ND</b>	Acryl-Nitrile-BuNa 75 shore ±5% black
- <b>NDG 86/108/143</b>	Acryl-Nitrile-BuNa 92 shore ±5% red
- <b>NDG 160/200</b>	Polyurethane 90 Shore ±5% black

**Polyamid ring**  
- **OMT** Polyamide 6.6

**Working temperature** -15°C +100°C

### COMPATIBILITY WITH MARINE SURROUNDINGS

On request all our bellhousings can be supplied with specific coating or surface treatment that makes them suitable for use in marine surroundings.

### SPECIAL APPLICATIONS

The present leaflet covers only standard applications. Our technical department is equipped to study on request special solutions for particular applications. Please contact our commercial department for further information.



GIUNTI IN ALLUMINIO / ALUMINIUM COUPLINGS

tipo / series **ND**

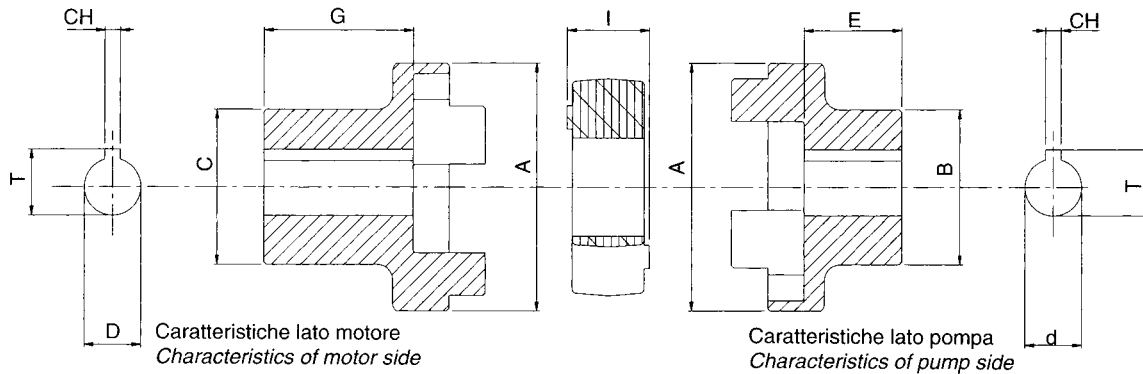

GIUNTI IN ALLUMINIO CHIUSI / BLANK ALUMINIUM COUPLINGS

tipo / series **NS**

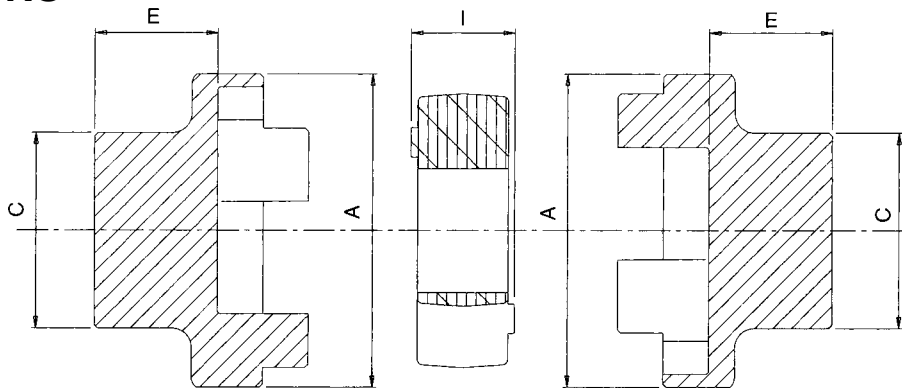

INSERTI ELASTICI / RUBBER SPIDERS

tipo / series **R**

Tabella / Table 11

Taglia giunto Coupling size	Inserto elastico / Rubber spider			
	Tipo Type	Dimensioni (mm) / Dimensions (mm)		
		l	Ø	d albero max
48	R-42	16	19	14
65	R-62	18	29	22
86	R-82	20	31,5	24
108	R-103	24	42	32
143	R-132	29	64	50

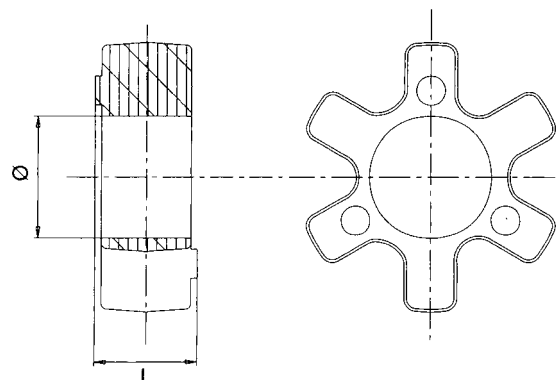

DATI TECNICI / TECHNICAL DATA

Tipo Type	Coppia massima (Nm) Max. torque (Nm)	Potenza max a n° giri/min max. power at revs/min				Disallineamento max Max. misalignment		
		750	1000	1500	3000	Angolare Angular	Radiale (mm) Radial (mm)	Assiale (mm) Axial (mm)
ND 48	6,86	0,54	0,72	1,1	2,1	2°	0,5	1
ND 65	38,2	3	4	6	12	2°	1	1,6
ND 86	87,3	6,84	9,12	13,7	27,3	2°	1	1,8
ND 108	210	16,5	22	33	65,8	2°	1	2
ND 143	725	57	76	144	228	2°	1	2

Coppie limite in [Nm] dei semigiunti e disallineamenti massimi.

Entrambe le versioni dei giunti hanno le capacità di:

- Sopportare disallineamenti angolari
- Sopportare disallineamenti radiali
- Sopportare disallineamenti assiali

Max. misalignment and torque in Nm supported by OMT halfcouplings.

Both versions of couplings can partially compensate angular, radial and axial misalignments.

Tabella / Table 12

Potenza motore 4 poli 1450 giri/1' Motor power 4 poles 1450 revs/min			Semigiunto lato motore Halfcoupling motor side					Semigiunto lato condotto / Halfcoupling pump side						Manicotto trascinatore Polyamide ring				Filo granaio Grid screw			
kW	Tg. Size	HP	Codice Part number	Dimensioni / Dimensions (mm)					Codice Part number	Dimensioni / Dimensions (mm)					Codice Part number	A	C		G	M	
				B	E	D	CH	T		B	E (lunghezza) / Dim. "E" (length)			D max							
0,12 ÷ 0,18	63	0,16 ÷ 0,25	OMT1023C02	23	23	11	4	12,8	OMT1 **	23	23	30			14	POL-1	40	40	4	M6	
0,25 ÷ 0,37	71	0,35 ÷ 0,55	OMT1030C07	23	30	14	5	16,3													
0,55 ÷ 0,75	80	0,75 ÷ 1	OMT2040C20	45	40	19	6	21,8	OMT2 **	45	33	40	50		24	POL-2	55	42	4	M6	
1,1 ÷ 1,5	90	1,5 ÷ 2	OMT2050C31	45	50	24	8	27,3													
2,2 ÷ 4	100 ÷ 112	3 ÷ 5,5	OMT3060C36	57	60	28	8	31,3	OMT3 **	57	30	40	60		32	POL-3	70	45	4	M6	
5,5 ÷ 9	132	7,5 ÷ 12,5	OMT4080C47	69	80	38	10	41,3	OMT4 **	69	40	50	55	60	80	38	POL-4	86	48	4	M8
11 ÷ 15	160	15 ÷ 20	OMT5110C51	81	110	42	12	45,3	OMT5 **	81	60	80	110		48	POL-5	102	50	4	M8	
18,5 ÷ 22	180	25 ÷ 30	OMT5110C54	81	110	48	14	51,8													
30	200	40	OMT6110C56	99	110	55	16	59,3	OMT6 **	99	62,5	80	110	140	65	POL-6	150	72	8	M10	
37 ÷ 45	225	50 ÷ 60	OMT6140C57	99	140	60	18	64,4													
55	250	75	OMT6140C58	99	140	65	18	69,4													
75 ÷ 90	280	100 ÷ 125	OMT7140C60	124	140	75	20	79,9	OMT7 **	124	140	90		80	POL-7	180	93	8	M10		
110	315s	150	OMT7140C61	124	140	80	22	85,4													

\*\* Vedi pagina 24 per codifica semigiunto

\*\* See pag. 24 for halfcoupling part number

Tabella / Table 13

Codice Part number	Dimensioni (mm) Dimensions (mm)			Codice Part number	Dimensioni (mm) Dimensions (mm)			Codice Part number	Dimensioni (mm) Dimensions (mm)		
	B	D max	E		B	D max	E		B	D max	E
OMT 1023C	23	14	23	OMT 4040C	69	38	40	OMT 6062C	99	65	62,5
OMT 1030C	23	14	30	OMT 4050C	69	38	50	OMT 6080C	99	65	80
OMT 2033C	45	24	33	OMT 4055C	69	38	55	OMT 6110C	99	65	110
OMT 2040C	45	24	40	OMT 4060C	69	38	60	OMT 6140C	99	65	140
OMT 2050C	45	24	50	OMT 4080C	69	38	80	OMT 7090C	124	80	90
OMT 3030C	46	32	30	OMT 5060C	81	48	60	OMT 7140C	124	80	140
OMT 3040C	57	32	40	OMT 5080C	81	48	80				
OMT 3060C	57	32	50	OMT 5110C	81	48	110				

SEMIGIUNTI IN ACCIAIO / STEEL HALFCOUPLINGS

tipo / series **OMT**

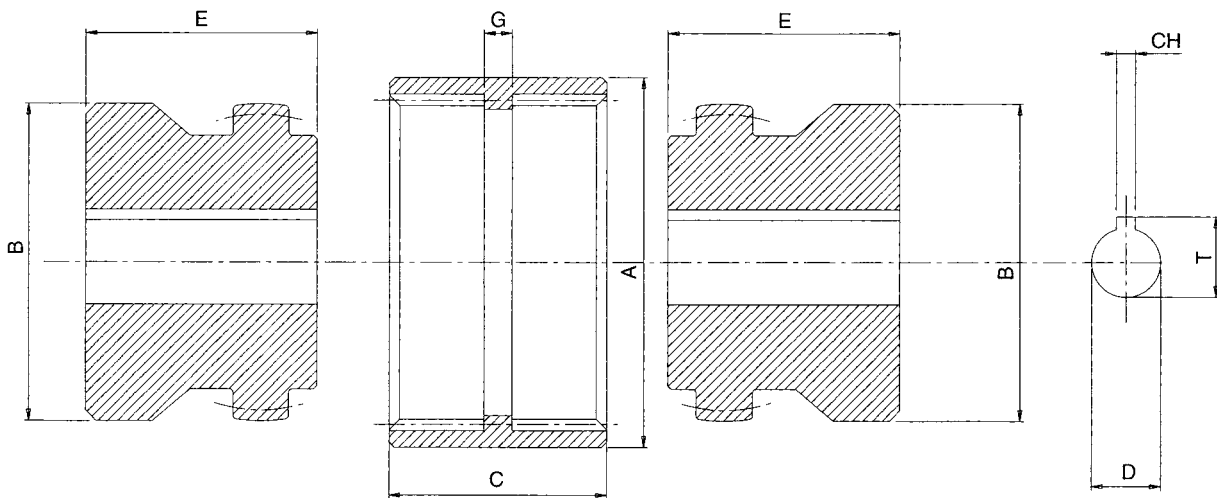

SEMIGIUNTI IN ACCIAIO CHIUSI / BLANK STEEL HALFCOUPLINGS

tipo / series **OMT**

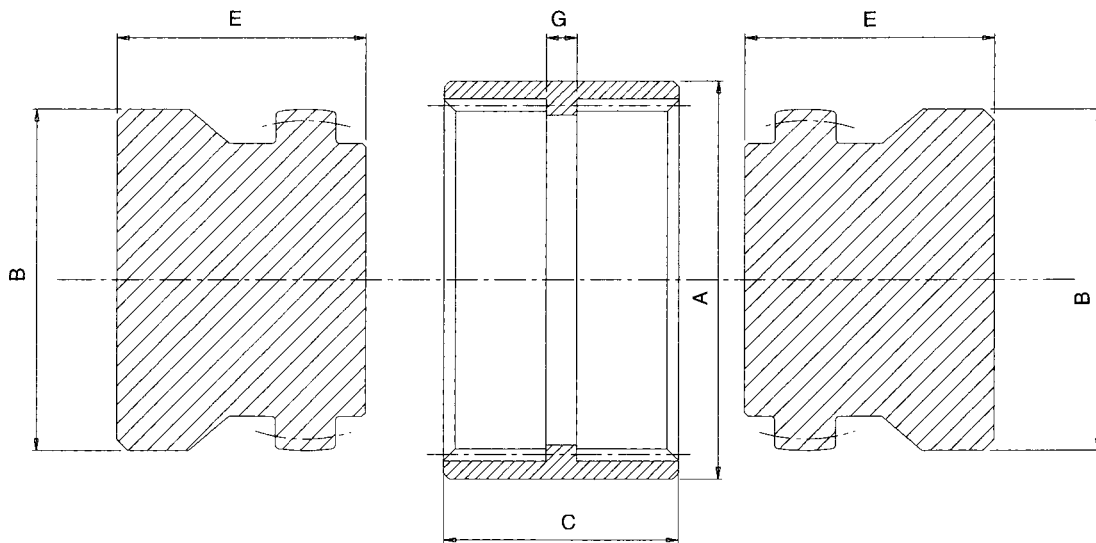

DATI TECNICI / TECHNICAL DATA

Coppie limite in [Nm] dei semigiunti e disallineamenti massimi.

Max. misalignment and torque in Nm supported by OMT halfcouplings.

Entrambe le versioni dei giunti hanno le capacità di:

Both versions of couplings can partially compensate angular, radial and axial misalignments.

- Sopportare disallineamenti angolari
- Sopportare disallineamenti radiali
- Sopportare disallineamenti assiali

Taglia Size	Coppia limite Max. torque	Potenza max a n° giri/min / Max. power at revs/min kW				Disallineamento max / Max. misalignment		
	Nm max	750	1000	1500	3000	Angolare Angular	Radiale (mm) Radial (mm)	Assiale (mm) Axial (mm)
<b>OMT1</b>	19,62	1,55	2	3	6,1	2°	0,14	1
<b>OMT2</b>	42,2	3,3	4,41	6,6	13,3	2°	0,5	1
<b>OMT3</b>	112,8	9,1	12,2	17,7	35,4	2°	0,5	1
<b>OMT4</b>	186,4	14	19,5	29,2	58,5	2°	0,5	1
<b>OMT5</b>	269,8	21,2	28,2	42,3	84,5	2°	0,5	1
<b>OMT6</b>	412	32,8	43	64,7	130	2°	0,6	1
<b>OMT7</b>	715,8	56,2	74,9	112,4	224,8	2°	0,6	1

Tabella / Table 14

Potenza motore 4 poli 1450 giri/1' Motor power 4 poles 1450 revs/min			Semigiunto lato motore Motor side halfcoupling					Semigiunto lato pompa Pump side halfcoupling					Inserto elastico Rubber spider	Filettatura Grub screw	Semigiunti chiusi Blank halfcouplings							
kW	Taglia Size	HP	Codice Part number	Dimensioni / Dimensions (mm)					Codice Part number	Dimensioni / Dimensions (mm)					Codice Part number	M	Codice Part number	Dimensioni / Dimensions (mm)				
				A	C	D	G	CH		T	A	B	D max	E max				E min	A	C	G	D max
2,2 ÷ 4	100 ÷ 112	3 ÷ 5,5	<b>NDG86-060C36</b>	81	55	28	60	8	31,3	<b>NDG86**</b>	81	55	28	60	20	R-82-92	M8	<b>NSG86</b>	81	55	60	28
5,5 ÷ 9	132	7,5 ÷ 12,5	<b>NDG108-080C47</b>	102	74	38	80	10	41,3	<b>NDG108**</b>	102	74	55	110	30	R-103-92	M8	<b>NSG108</b>	102	74	110	55
11 ÷ 15	160	15 ÷ 20	<b>NDG108-110C51</b>	102	74	42	110	12	45,3									<b>NSG143</b>	134	107	110	65
18,5 ÷ 22	180	25 ÷ 30	<b>NDG108-110C54</b>	102	74	48	110	14	51,8									<b>NSG160A</b>	160	135	140	75
30	200	40	<b>NDG108-110C56</b>	102	74	55	110	16	59,3									<b>NSG160B</b>	160	135	85	75
37 ÷ 45	225	50 ÷ 60	<b>NDG143-110C57</b>	134	107	60	110	18	64,4	<b>NDG143**</b>	134	107	65	110	30	R-132-92	M10	<b>NSG160C</b>	160	157	85	90
55	250	75	<b>NDG143-110C58G2</b>	134	107	65	110	18	69,4									<b>NSG200</b>	200	200	100	100
75 ÷ 90	280	100 ÷ 125	<b>NDG160-085C60G2</b>	160	135	75	85	20	79,9	<b>NDG160**</b>	160	135	75	140	30	R-160-92	M10					
110 ÷ 132	315	150 ÷ 180	<b>NDG160-085C61G2</b>	160	157	80	85	22	85,4													

\*\* Vedi pagina 24 per codifica semigiunto

\*\* See pag. 24 for halfcoupling part number

Per potenze superiori ai 132 kW contattare l'ufficio commerciale per la realizzazione dell'accoppiamento.  
I semigiunti lato pompa possono essere accorciati con passo di 5 mm e non oltre la misura consentita (E min).

For couplings for motors above 132 kW please contact our sales department.

Halfcouplings can be shortened in steps of 5 mm and not beyond the indicated minimum length (E min).

## SEMIGIUNTI IN GHISA / CAST IRON HALF COUPLINGS

tipo / series **NDG**

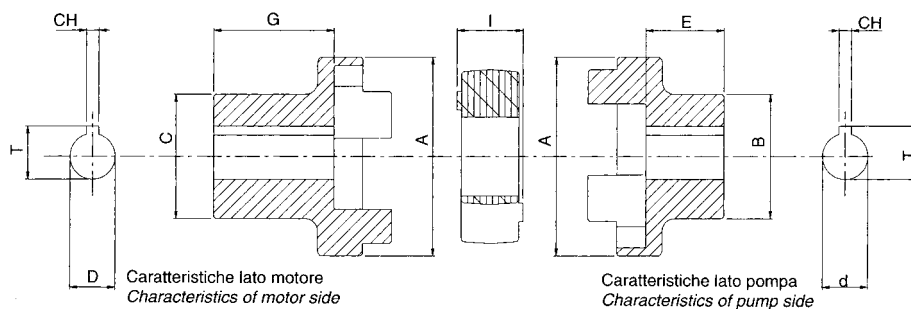

### DATI TECNICI TECHNICAL DATA

Codice Part number	Coppia nominale Rated torque (Nm)	Coppia limite Max torque (Nm)
<b>NDG86</b>	90	180
<b>NDG 108</b>	260	520
<b>NDG143</b>	300	600
<b>NDG160</b>	1200	2400

## INSERTI ELASTICI / RUBBER SPIDERS

tipo / series **R**

Tabella / Table 15

Tipo di semigiunto Size of coupling	Inserto elastico / Rubber spider			
	Codice Part number	Dimensioni (mm) / Dimensions (mm)		
		I	Ø	D max
NDG86	<b>R-82-92</b>	20	31,5	24
NDG108	<b>R-103-92</b>	24	42	32
NDG143	<b>R-132-92</b>	29	64	50
NDG160	<b>R-160-92</b>	37	80	60
NDG200	<b>R-200-92</b>	41	100	80



Tabella / Table 16

Codice Part number	Tabella / Table "A" DIN 5480		Tabella / Table "B" DIN 5482		Tabella / Table "E" ANS.B.92.1-1970	
	Z	Tipo / Type	Z	Tipo / Type	Z	Spline size
01	14	W20x1,25x14	8	15x12	13	8/16
02	18	W25x1,25x18	9	17x14	15	8/16
03	6	W15x2x6	10	18x15	17	8/16
04	6	W16x2x6	12	20x17	14	12/24
05	7	W17x2x7	13	22x19	16	12/24
06	-	-	14	25x22	17	12/24
07	8	W20x2x8	15	28x25	9	16/32
08	9	W22x2x9	16	30x27	11	16/32
09	11	W25x2x11	17	32x28	12	16/32
10	12	W28x2x12	18	35x31	13	16/32
11	13	W30x2x13	19	38x34	15	16/32
12	14	W30x2x14	20	40x36	21	16/32
13	14	W32x2x14	21	42x38	23	16/32
14	16	W35x2x16	22	45x41	27	16/32
15	17	W37x2x17	23	48x44	40	24/48
16	18	W38x2x18	24	50x45	14	24/48
17	18	W40x2x18	25	52x47	20	24/48
18	20	W42x2x20	26	55x50	21	24/48
19	21	W45x2x21	27	58x53	23	24/48
20	24	W50x2x24	28	60x55	25	24/48
21	26	W55x2x26	29	62x57	26	24/48
22	28	W58x2x28	30	65x60	27	24/48
23	28	W60x2x28	31	68x62	28	24/48
24	31	W65x2x31	32	70x64	29	24/48
25	34	W70x2x34	33	72x66	32	24/48
26	30	W80x2x38	34	75x69	21	32/64
27	-	-	35	78x72	24	32/64
28	-	-	36	80x74	30	32/64
29	-	-	37	82x76	33	32/64
30	-	-	38	85x79	23	40/80
31	-	-	39	88x82	36	48/96
32	-	-	40	90x84	41	48/96
33	-	-	41	92x86	47	48/96
34	-	-	42	95x89	-	-
35	-	-	43	98x92	-	-
36	-	-	44	100x94	-	-
37	-	-	8	32x36**	-	-

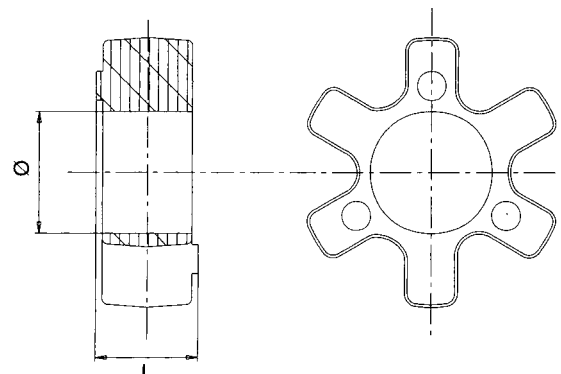

Tabella / Table 18

Codice Part number	Lavorazione per albero condotto Machining of pump side			Secondo la normativa According to standard
	Dimensioni / Dimensions (mm)			
	d	ch	t	
01	10	3	11,4	
02	11	4	12,8	UNEL- MEC 63
03	12	3	13,8	
04	12	4	13,8	
05	13,45	3,17	14,9	
06	14	3	16,3	
07	14	5	16,3	UNEL- MEC 71
08	15	4	17,3	
09	15	5	17,3	
10	15,88	4	17,7	SAE
11	15,88	4,76	18,1	
12	16	4	17,5	
13	16	5	18,3	
14	17	5	19,3	
15	17,46	4,76	19,6	
16	18	5	20,3	
17	18	6	20,8	
18	19	3	20,8	
19	19	5	21,3	
20	19	6	21,8	UNEL- MEC 80
21	19,05	3,17	20,7	
22	19,05	4,76	21,3	SAE A
23	20	5	22,4	
24	20	6	22,8	ISO 80
25	22	5	24,8	
26	22	6	24,8	
27	22,22	4,76	24,8	SAE B
28	22,22	6,35	25	
29	24	6	26,5	
30	24	7	27,3	
31	24	8	27,3	UNEL- MEC 90
32	25	6	28	ISO 100
33	25	7	28,3	ISO 100
34	25	8	28,3	ISO 100
35	25,4	6,35	28,8	ISO 100
36	28	8	31,3	UNEL-MEC 100-112
37	30	8	33,3	
38	30	10	33,3	
39	31,75	6,35	35,1	SAE C
40	31,75	7,94	35,5	
41	31,75	8	35,5	
42	32	8	35,3	
43	32	10	35,3	ISO 125
44	33	10	36,3	
45	34,9	7,94	38,6	SAE
46	35	10	38,3	
47	38	10	41,3	UNEL- MEC 132
48	38,1	9,52	42,5	SAE
49	40	10	43,3	
50	40	12	43,3	ISO 160
51	42	12	45,3	UNEL- MEC 160
52	44,45	11,11	49,4	SAE
53	45	14	48,8	
54	48	14	51,8	UNEL- MEC 180
55	50	14	53,8	ISO 200
56	55	16	59,3	UNEL- MEC 200
57	60	18	64,4	UNEL- MEC 225
58	65	18	69,4	UNEL- MEC 250
59	70	20	74,9	
60	75	20	79,9	UNEL- MEC 280
61	80	22	85,4	UNEL- MEC 315S
62	12,7	3,18	13,8	
63	38,1	7,94	42	
64	9	4	11	
65	11	3	12,8	
66	9	3	11	
67	6	2	7	
68	7	2	8	

97, 98, 99 solo per giunti di tipo in alluminio e ghisa  
97, 98, 99 only on cast-iron and aluminium couplings

\*\* DIN 5462

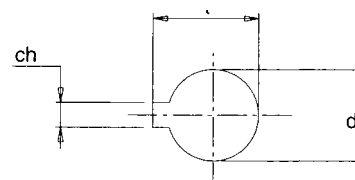
**LATO MOTORE**

- alluminio
- ghisa
- acciaio

Vedi tabelle in corrispondenza della potenza motore

**MOTOR SIDE**

- aluminium
- cast iron
- steel

Choose from tables according to required power

**TRASCINATORE**

- per alluminio R-\*\*\* vedi tabella 11 pag. 17
- per ghisa R-\*\*\*-92 vedi tabella 15 pag. 20
- per acciaio POL-\* vedi tabella 12 pag. 18

**INSERT/RING**

- aluminium R-\*\*\* see table 11 pag. 17
- cast iron R-\*\*\*-92 see table 15 pag. 20
- steel POL-\* see table 12 pag. 18

**LATO CONDOTTO, ALLUMINIO  
ND, NS**

sigla identificativa del tipo di semigiunto

- 65H grandezza nominale del semigiunto
- 2 accorciatura "E" del semigiunto
- D senza foro grano (esclude la "C")
- C con foro grano (esclude la "D")
- 24 codice di foratura da eseguire (vedi tab.18)

Esempio: **ND65H2D24 - ND65H2C24**

**PUMP SIDE, ALUMINIUM  
ND, NS**

identifies type of halfcoupling

- 65H nominal size of halfcoupling
- 2 shortening "E" of halfcoupling
- D without grub screw (excludes version "C")
- C with grub screw (excludes version "D")
- 24 reference of required boring (see table 18)

Example: **ND65H2D24 - ND65H2C24**

**LATO CONDOTTO, GHISA  
NDG**

sigla identificativa del tipo di semigiunto

- 86 grandezza nominale del semigiunto
- 060 accorciatura "E" del semigiunto
- D senza foro grano (esclude la "C")
- C con foro grano (esclude la "D")
- 36 codice di foratura da eseguire (vedi tab.18)

Esempio: **NDG86-060D36 - NDG86-060C36**

**PUMP SIDE, CAST IRON  
NDG**

identifies type of halfcoupling

- 86 nominal size of halfcoupling
- 060 shortening "E" of halfcoupling
- D without grub screw (excludes version "C")
- C with grub screw (excludes version "D")
- 36 reference of required boring (see table 18)

Example: **NDG86-060D36 - NDG86-060C36**

**LATO CONDOTTO, ACCIAIO  
OMT**

sigla identificativa del tipo di semigiunto

- 2 grandezza nominale del semigiunto
- 050 accorciatura "E" del semigiunto
- D senza foro grano (esclude la "C")
- C con foro grano (esclude la "D")
- 24 codice di foratura da eseguire (vedi tab.18)

Esempio: **OMT2050D24 - OMT2050C24**

**PUMP SIDE, STEEL  
OMT**

identifies type of halfcoupling

- 2 nominal size of halfcoupling
- 050 shortening "E" of halfcoupling
- D without grub screw (excludes version "C")
- C with grub screw (excludes version "D")
- 24 reference of required boring (see table 18)

Example: **OMT2050D24 - OMT2050C24**

**LATO CONDOTTO, PROFILO SCANALATO  
OMT, NDG**

sigla identificativa del tipo di semigiunto

- 2 grandezza nominale del semigiunto
- 050 accorciatura "E" del semigiunto
- S sigla identificativa per scanalatura
- E tipo di scanalatura (vedi tab.16)
- 07 codice scanalatura da eseguire (vedi tab.16)

Esempio: **OMT2050SE07 - NDG86-045SE10**

**PUMP SIDE, SPLINED PROFILE  
OMT, NDG**

identifies type of halfcoupling

- 2 nominal size of halfcoupling
- 050 shortening "E" of halfcoupling
- S indicated splined profile
- E type of splining (see table 16)
- 07 reference of required splining (see table 16)

Example: **OMT2050SE07 - NDG86-045SE10**

FLANGIA / FLANGE

tipo / series **B3 - B5**

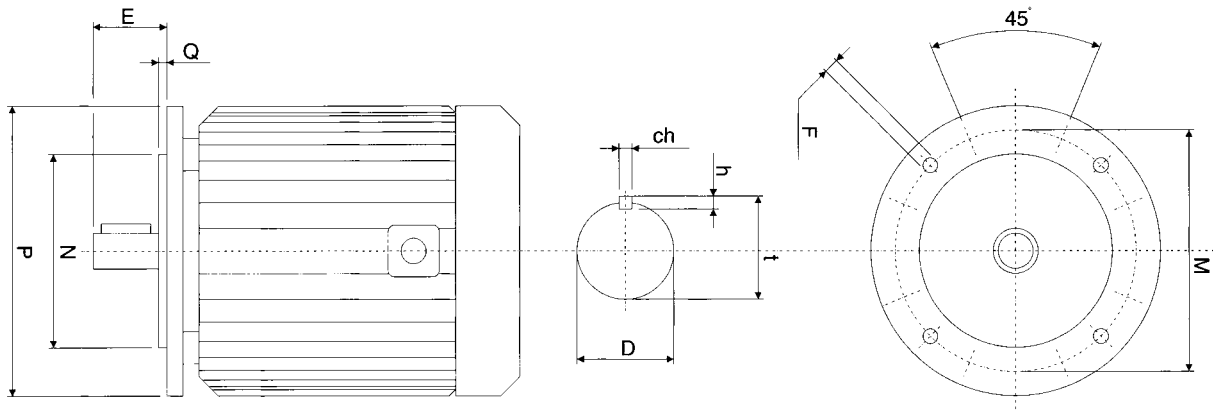

Dati tecnici motori / Technical data of motors																		
Taglia Size	2 poli / 2 poles		4 poli / 4 poles		6 poli / 6 poles		8 poli / 8 poles		Dimensioni flangia / Dimensions flange					Dimensioni albero / Dimensions of shaft				
	2900 giri/min - revs/min		1450 giri/min - revs/min		960 giri/min - revs/min		720 giri/min - revs/min		P	M	N	Q	F	D	E	ch	b	t
	kW	HP	kW	HP	kW	HP	kW	HP										
<b>80</b>	0,75 1,1	1 1,5	0,55 0,75	0,75 1	0,37 0,55	0,5 0,75	0,18 0,25	0,25 0,35	200	165	130	3,5	11,5	19	40	6	6	21,8
<b>90</b>	1,5 2,2	2 3	1,1 1,5	1,5 2	0,75 1,1	1 1,5	0,37 0,55	0,5 0,75	200	165	130	3,5	11,5	24	50	8	7	27,3
<b>100</b>	3	4	2,2 3	3 4	1,5	2	0,75 1,1	1 1,5	250	215	180	4	14	28	60	8	7	31,3
<b>112</b>	4	5,5	4	5,5	2,2	3	1,5	2	250	215	180	4	14	28	60	8	7	31,3
<b>132</b>	5,5 9	7,5 12,5	5,5 9	7,5 12,5	3 5,5	4 7,5	2,2 3	3 4	300	265	230	4	14	38	80	10	8	41,3
<b>160</b>	11 18,5	15 25	11 15	15 20	7,5 11	10 15	4 7,5	5,5 10	350	300	250	5	18	42	110	12	8	45,3
<b>180</b>	22	30	18,5 22	25 30	15	20	11	15	350	300	250	5	18	48	110	14	9	51,8
<b>200</b>	30 37	40 50	30	40	18,5 22	25 30	15	20	400	350	300	5	18	55	110	16	10	59,3
<b>225</b>	45	60							450	400	350	5	18	55	110	16	10	59,3
<b>225</b>			37 45	50 60	30	40	18,5 22	25 30	450	400	350	5	18	60	140	18	11	64,4
<b>250</b>	55	75							550	500	450	5	18	60	140	18	11	64,4
<b>250</b>			55	75	37	50	30	40	550	500	450	5	18	65	140	18	11	69,4
<b>280</b>	75 90	100 125							550	500	450	5	18	65	140	18	11	69,4
<b>280</b>			75 90	100 125	45 55	60 75	37 45	50 60	550	500	450	5	18	75	140	20	12	79,9
<b>315 S</b>	110	150							660	600	550	6	22	65	140	18	11	69,4
<b>315 S</b>			110	150	75 90	100 122	55	75	660	600	550	6	22	80	170	22	14	85,4

## ACCOPIAMENTI TRA MOTORI ELETTRICI A FLANGIA UNIFICATA B3 - B5 - B14 POMPE OLEODINAMICHE AD INGRANAGGI

### CONNECTIONS BETWEEN ELECTRICAL MOTORS WITH STANDARD B3 - B5 - B14 FLANGE AND HYDRAULIC GEAR PUMPS

Nelle pagine che seguiranno sono riportati tutti gli accoppiamenti standard che la OMT S.p.A. realizza per l'assemblaggio di motori elettrici e pompe ad ingranaggi fino ad una potenza di 45 kW.

On the following pages we list the complete program of standard couplings for use with electrical motors up to 45 kW and hydraulic gear pumps, as manufactured by OMT SpA.

#### DATI:

**Potenza del motore**

**Grandezza della pompa** da scegliere sulle tabelle a seconda della flangiatutura della pompa stessa e del tipo di albero

#### DATA:

**Motor power**

**Size of pump**

to be chosen from the following table according to the flange type and the shaft of the pump.

Si possono trovare i codici della lanterna e dei semi-giunti necessari all'accoppiamento ideale e le relative dimensioni di ingombro.

In the following table you can find the part numbers as well as the dimensions of the bellhousings and couplings needed to realize the connection between pump and motor.



Tabella / Table 19 Rif. pompa / Pump code

Taglia / Size	Tipo flangia / Type of flange	Rif. pompa Pump code	Pompa / Pump				
			Dimensioni / Dimensions (mm)				
			E	L	M	N	O
<b>0,5</b>	Standard	<b>05M/05GT</b>	22	25,5	66	-	M6
<b>1</b>	Standard	<b>U 1 P</b>	25,4	26,2	72	52	M6
<b>1</b>	Marzocchi	<b>1C/1M</b>	30	24,5	73	56	M6
<b>2</b>	Standard	<b>2</b>	36,5	32,5	96	71,5	M8
<b>3</b>	Turolla (Sauer) Dowty	<b>T250</b>	50,8	43	128	98,5	M8
<b>3</b>	Standard	<b>3 U</b>	50,8	42	128	98,5	M10
<b>3</b>	Marzocchi - HPI	<b>M 3</b>	50,8	43	128	98,5	M10
<b>3</b>	Turolla (Sauer)	<b>T 3</b>	50,8	45	137	98,5	M10
<b>3,5</b>	Marzocchi	<b>35 M</b>	60	48,2	148	127	M12
<b>3,5</b>	Standard	<b>35 U</b>	60,3	49,5	149,5	114,3	M10
<b>4</b>	Marzocchi - Turolla (Sauer)	<b>4M/4T</b>	63,5	65	196	142,8	M12
<b>4</b>	Standard	<b>4 U</b>	63,5	64,3	188	143	M12
<b>GR. BOSCH</b>	Bosch tipo ZBR	<b>ZB</b>	32	10,3	40	40	M8
<b>GR. BOSCH</b>	Bosch tipo ZFR - S	<b>ZF</b>	80	34,5	100	72	M8
<b>GR. BOSCH</b>	Bosch tipo ZGR - S	<b>ZG</b>	105	48	145	102	M10

#### Applicazioni speciali

Per tutte le applicazioni che non rientrano nei casi normali specificati in questi cataloghi contattare l'ufficio commerciale della OMT S.p.a. per un eventuale studio di fattibilità.

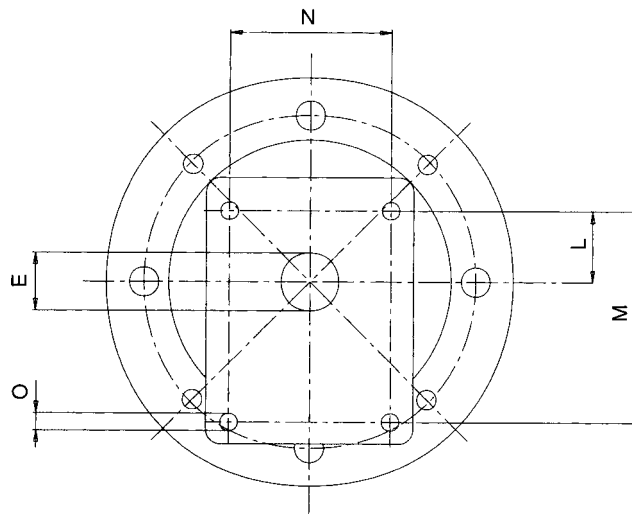
#### Special applications

For all applications not foreseen by this catalogue please contact our commercial department. We will be pleased to verify the possibility to realize a special connection.

**TIPOLOGIA DELLE LANTERNE DISPONIBILI / TYPE OF AVAILABLE BELLHOUSINGS**

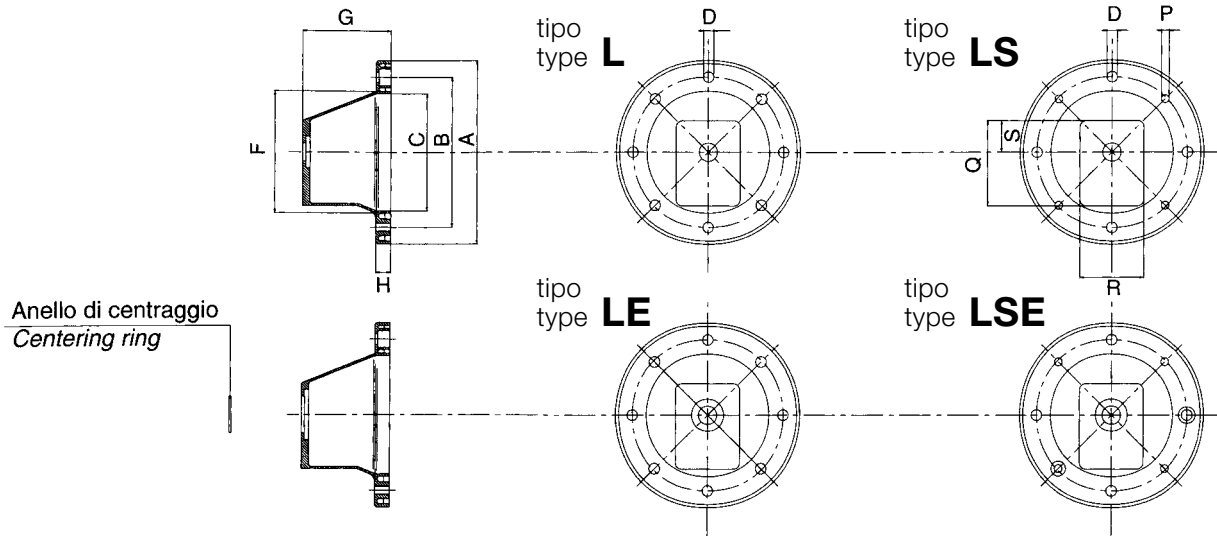

- L** 8 fori passanti lato motore  
8 passing holes on motor side
- LS** 4 fori passanti + 4 fori filettati lato motore  
4 passing holes + 4 threaded holes on motor side

- LE** 8 fori passanti lato motore e anello di centraggio in lamiera per estrazione del giunto  
8 passing holes on motor side + sheet metal centering ring for the extraction of the coupling.
- LSE** 4 fori passanti + 4 fori filettati lato motore e anello di centraggio in lamiera per estrazione del giunto  
4 passing holes + 4 threaded holes on motor side + sheet metal centering ring for the extraction of the coupling.

Tabella / Table 20

Potenza motore 4 poli 1450 giri/1'			Semigiunto lato motore Motor side halfcoupling						
Motor power 4 poles 1450 revs/min			Codice Part number	Dimensioni / Dimensions (mm)					
kW	Taglia Size	HP		A	C	G	D	CH	T
0,12	63	0,16	ND 48A	48	30	19	11	4	12,8
0,18		0,25							
0,25	71	0,35	ND 48B	48	30	29	14	5	16,3
0,37		0,55							
0,55	80	0,75	ND 48C	48	38	54	19	6	21,8
0,75		1							
1,1	90	1,5	ND 48D	48	38	54	24	8	27,3
1,5		2							
0,55	80	0,75	ND 65A	65	42	47,5	19	6	21,8
0,75		1							
1,1	90	1,5	ND 65B	65	48	47,5	24	8	27,3
1,5		2							
2,2	100	3	ND 65C	65	53	57,5	28	8	31,3
4		5,5							
2,2	112	3	ND 86A	86	55	60	28	8	31,3
4		5,5							
5,5	132	7,5	ND 86B	86	73	88	38	10	41,3
9		12,5							
5,5	132	7,5	ND 108A	108	73	77	38	10	41,3
9		12,5							
11	160	15	ND 108B	108	84	110	42	12	45,3
15		20							
18,5	180	25	ND 108C	108	100	110	48	14	51,8
22		30							
30	200	40	ND 108D	108	100	110	55	16	59,3
30	200	40	ND 143B	143	106	110	55	16	59,3
37	225	50	ND 143C	143	137	140	60	18	64,4
45		60							



Tabella / Table 21

Rif. pompa Pump code	Dimensioni (mm) lato pompa / Dimensions (mm) pump side				
	Tipo / Type	d	Ch	t	L
<b>05 M</b>	cilindrico / cylindric	6	2	7	10
<b>05 GT</b>	cilindrico / cylindric	7	2	8	10
<b>1 C</b>	cilindrico / cylindric	12	3	13,3	13,5
<b>U1P</b>	con 1:8 / taper 1:8	9,7	2,4	10,5	15
<b>1M</b>	con 1:8 / taper 1:8	13,9	3	15,5	18,5
<b>2 (CA)</b>	con 1:8 / taper 1:8	17,2	3,2	18,5	23
<b>2 (U)</b>	con 1:8 / taper 1:8	17,2	4	18,5	23
<b>3U</b>	con 1:8 / taper 1:8	22,2	4	23,6	28
<b>35 (U)</b>	con 1:8 / taper 1:8	25,6	4,76	27,8	35
<b>35 (M)</b>	con 1:8 / taper 1:8	25,6	5	27,8	35
<b>4 (U)</b>	con 1:8 / taper 1:8	33,3	6,35	35,5	45
<b>4 (M/T)</b>	con 1:8 / taper 1:8	33,3	7	35,5	45
<b>ZB</b>	con 1:5 / taper 1:5	9,8	2	10,2	12
<b>ZF</b>	con 1:5 / taper 1:5	16,9	3	17,7	19
<b>ZG</b>	con 1:5 / taper 1:5	25,2	5	26,3	29

MOTORI FLANGIA B3-B5 / MOTORS WITH FLANGE B3-B5

Motore 4 poli 1450 giri/1' Motor power 4 p. 1450 revs/min		Rif. pompa Pump code	Lanterna Bellhousing				Dimensione lanterna (mm) Dimensions of bellhousing (mm)										Giunto completo serie ND Complete coupling ND series		Semigiunto motore Halfcoupling motor side	Inserto elastico Rubber spider	Semigiunto pompa Halfcoupling pump side	Anelli di centraggio Centering ring	Piedino Foot flange	Anello Amm. Suitable damping ring						
kW	Taglia Size		HP	LE	LSE	L	LS	A	B	C	D	F	G	H	P	Q	R	S	Codice Part number	H	Codice Part number	Codice Part num.	I	Codice Part number	Anelli di centraggio Centering ring	Piedino Foot flange	Anello Amm. Suitable damping ring			
0,12 ÷ 0,18	63	0,16 ÷ 0,25	05 M	-	-	1401	140	140	115	95	10	100	60	11	M8	90	69	34	ND 01	54	ND 48A	R-42	16	ND 48P05M	-	-	-	-	-	
			05 GT	-	-	1401	140	140	115	95	10	100	60	11	M8	90	69	34	ND 02	54	ND 48A	R-42	16	ND 48P05GT	-	-	-	-	-	
			U 1 P	1402	141	1402	141	140	140	115	95	10	100	60	11	M8	90	69	34	ND 03	52	ND 48A	R-42	16	ND 48PU1P	RC1-254	-	-	-	-
			1 C	1403	142	1403	142	140	140	115	95	10	100	60	11	M8	90	69	34	ND 04	52	ND 48A	R-42	16	ND 48P1C	RC1-30	-	-	-	-
			1 M	1403	142	1403	142	140	140	115	95	10	100	60	11	M8	90	69	34	ND 05	52	ND 48A	R-42	16	ND 48P1M	RC1-30	-	-	-	-
			ZB	-	-	LB18	LBS18	140	140	115	95	10	100	60	11	M8	90	69	34	ND 198	52	ND 48A	R-42	16	ND 48PZB	-	-	-	-	-
			ZF	-	-	-	-	-	-	-	-	-	-	-	-	-	-	-	-	-	-	-	-	-	-	-	-	-	-	-
0,25 ÷ 0,37	71	0,35 ÷ 0,55	05 M	-	-	1601	160	160	130	110	10	110	70	14	M8	90	69	34	ND 1	64	ND 48B	R-42	16	ND 48P05M	-	-	-	-	-	
			05 GT	-	-	1601	160	160	130	110	10	110	70	14	M8	90	69	34	ND 1A	64	ND 48B	R-42	16	ND 48P05GT	-	-	-	-	-	
			U 1 P	1602	161	1602	161	160	160	130	110	10	110	70	14	M8	90	69	34	ND 2	62	ND 48B	R-42	16	ND 48PU1P	RC1-254	-	-	-	-
			1 C	1603	162	1603	162	160	160	130	110	10	110	70	14	M8	90	69	34	ND 3	62	ND 48B	R-42	16	ND 48P1C	RC1-30	-	-	-	-
			1 M	1603	162	1603	162	160	160	130	110	10	110	70	14	M8	90	69	34	ND 3A	62	ND 48B	R-42	16	ND 48P1M	RC1-30	-	-	-	-
			ZB	-	-	LB19	LBS19	160	160	130	110	10	110	70	14	M8	90	69	34	ND 199	62	ND 48B	R-42	16	ND 48PZB	-	-	-	-	-
			ZF	-	-	-	-	-	-	-	-	-	-	-	-	-	-	-	-	-	-	-	-	-	-	-	-	-	-	-
0,55 ÷ 0,75	80	0,75 ÷ 1	05 M	-	-	2101	210	200	165	130	12	135	87	15	M10	90	69	34	ND 4B	81	ND 48CG45	R-42	16	ND 48P05M	-	-	-	-	-	
			05 GT	-	-	2101	210	200	165	130	12	135	87	15	M10	90	69	34	ND 4C	81	ND 48CG45	R-42	16	ND 48P05GT	-	-	-	-	-	
			U 1 P	2102	211	2102	211	200	200	165	130	12	135	87	15	M10	90	69	34	ND 5A	78	ND 48CG45	R-42	16	ND 48PU1P	RC1-254	-	-	-	-
			1 C	2103	212	2103	212	200	200	165	130	12	135	87	15	M10	90	69	34	ND 6B	78	ND 48CG45	R-42	16	ND 48P1C	RC1-30	-	-	-	-
			1 M	2103	212	2103	212	200	200	165	130	12	135	87	15	M10	90	69	34	ND 6C	78	ND 48CG45	R-42	16	ND 48P1M	RC1-30	-	-	-	-
			ZB	-	-	LB28	LBS28	200	200	165	130	12	135	87	15	M10	90	69	34	ND 300	78	ND 48CG45	R-42	16	ND 48PZB	-	-	-	-	
			ZF	-	-	-	-	-	-	-	-	-	-	-	-	-	-	-	-	-	-	-	-	-	-	-	-	-	-	-
			05 M	-	-	2001	200	200	200	165	130	12	135	95	15	M10	90	69	34	ND 4	89	ND 48C	R-42	16	ND 48P05M	-	-	-	-	-
			05 GT	-	-	2001	200	200	200	165	130	12	135	95	15	M10	90	69	34	ND 4A	89	ND 48C	R-42	16	ND 48P05GT	-	-	-	-	-
			U 1 P	2002	201	2002	201	200	200	165	130	12	135	95	15	M10	90	69	34	ND 5	87	ND 48C	R-42	16	ND 48PU1P	RC1-254	-	-	-	-
			1 C	2003	202	2003	202	200	200	165	130	12	135	95	15	M10	90	69	34	ND 6	87	ND 48C	R-42	16	ND 48P1C	RC1-30	-	-	-	-
			1 M	2003	202	2003	202	200	200	165	130	12	135	95	15	M10	90	69	34	ND 6A	87	ND 48C	R-42	16	ND 48P1M	RC1-30	-	-	-	-
			ZB	-	-	LB20	LBS20	200	200	165	130	12	135	95	15	M10	90	69	34	ND 200	87	ND 48C	R-42	16	ND 48PZB	-	-	-	-	
			ZF	-	-	LB21	LBS21	200	200	165	130	12	135	95	15	M10	118	86	43	ND 7	87	ND 65A	R-62	18	ND 65P2	RC1-365	-	-	-	-
			T 250	2005	205	-	-	200	200	165	130	12	135	126	16	M10	180	158	65	ND 202	87	ND 65A	R-62	18	ND 65P2Z	-	-	-	-	
			3 U	2006	206	-	-	200	200	165	130	12	135	126	16	M10	180	158	65	ND 50A	116	ND 86HD20	R-82	20	ND 65PZF	RC2-508	-	-	-	
			M 3	2007	207	-	-	200	200	165	130	12	135	126	16	M10	180	158	65	ND 50A	116	ND 86HD20	R-82	20	ND 86H3U	RC2-508	-	-	-	
			T 3	2008	208	-	-	200	200	165	130	12	135	126	16	M10	180	158	65	ND 50A	116	ND 86HD20	R-82	20	ND 86H3U	RC2-508	-	-	-	
			35 M	2009	209	-	-	200	200	165	130	12	135	126	16	M10	180	158	65	ND 50B	116	ND 86HD20	R-82	20	ND 86H35	RC2-60	-	-	-	
			35 G	2010	213	-	-	200	200	165	130	12	135	126	16	M10	180	158	65	ND 50B	116	ND 86HD20	R-82	20	ND 86H35	RC2-603	-	-	-	
35 U	2010	213	-	-	200	200	165	130	12	135	126	16	M10	180	158	65	ND 50B	116	ND 86HD20	R-82	20	ND 86H35	RC2-603	-	-	-				
ZG	-	-	2011	214	200	200	165	130	12	135	126	16	M10	180	158	65	ND 50D	116	ND 86HD20	R-82	20	ND 86HZG	-	-	-	-				
1,1 ÷ 1,5	90	1,5 ÷ 2	U 1 P	2002	201	2002	201	200	165	130	12	135	95	15	M10	90	69	34	ND 70A	87	ND 48D	R-42	16	ND 48PU1P	RC1-254	-	-	-	-	
			1 C	2003	202	2003	202	200	200	165	130	12	135	95	15	M10	90	69	34	ND 70B	87	ND 48D	R-42	16	ND 48P1C	RC1-30	-	-	-	-
			1 M	2003	202	2003	202	200	200	165	130	12	135	95	15	M10	90	69	34	ND 70C	87	ND 48D	R-42	16	ND 48P1M	RC1-30	-	-	-	-
			ZB	-	-	LB20	LBS20	200	200	165	130	12	135	95	15	M10	90	69	34	ND 70D	87	ND 48D	R-42	16	ND 48PZB	-	-	-	-	
			U 1 P	2002	201	2002	201	200	200	165	130	12	135	95	15	M10	90	69	34	ND 8	87	ND 65B	R-62	18	ND 65PU1P	RC1-254	-	-	-	-
			1 C	2003	202	2003	202	200	200	165	130	12	135	95	15	M10	90	69	34	ND 9	87	ND 65B	R-62	18	ND 65P1C	RC1-30	-	-	-	-
			1 M	2003	202	2003	202	200	200	165	130	12	135	95	15	M10	90	69	34	ND 9A	87	ND 65B	R-62	18	ND 65P1M	RC1-30	-	-	-	-
			ZB	-	-	LB20	LBS20	200	200	165	130	12	135	95	15	M10	90	69	34	ND 201	87	ND 65B	R-62	18	ND 65PZB	-	-	-	-	
			ZF	-	-	LB21	LBS21	200	200	165	130	12	135	95	15	M10	118	86	43	ND 10	87	ND 65B	R-62	18	ND 65P2	RC1-365	-	-	-	
			T 250	2005	205	-	-	200	200	165	130	12	135	126	16	M10	180	158	65	ND 203	87	ND 65B	R-62	18	ND 65PZF	-	-	-	-	
			3 U	2006	206	-	-	200	200	165	130	12	135	126	16	M10	180	158	65	ND 51A	116	ND 86HD31	R-82	20	ND 86H3U	RC2-508	-	-	-	
			M 3	2007	207	-	-	200	200	165	130	12	135	126	16	M10	180	158	65	ND 51A	116	ND 86HD31	R-82	20	ND 86H3U	RC2-508	-	-	-	
			T 3	2008	208	-	-	200	200	165	130	12	135	126	16	M10	180</													

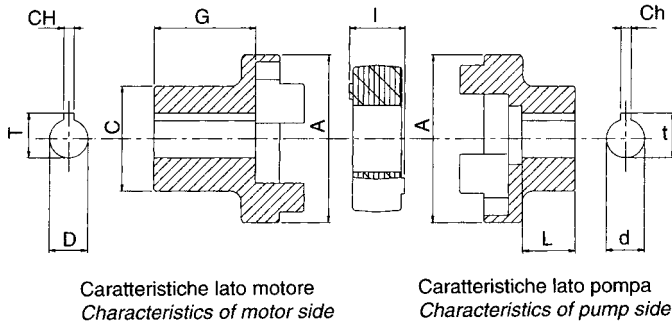

## MOTORI FLANGIA B3-B5 / MOTORS WITH FLANGE B3-B5

kW	Taglia Size	HP	Motore 4 poli 1450 giri/1' Motor power 4 p. 1450 revs/min	Rif. pompa Pump code	Lanterna Bellhousing				Dimensione lanterna (mm) Dimensions of bellhousing (mm)																Giunto completo serie ND Complete coupling ND series		Semigiunto Pompa Halfcoupling pump side		Inserto elastico Rubber spider		Semigiunto pompa Halfcoupling pump side		Piedino Foot flange	Anello Amm. Suitable damping ring
					LE	LSE	L	LS	A	B	C	D	F	G	H	P	Q	R	S	Codice Part number	H	Codice Part number	I	Codice Part number	I	Codice Part number								
0,12 ÷ 0,18	63	0,16 ÷ 0,25	05 M	-	-	1401	140	140	140	115	95	10	100	60	11	M8	90	69	34	AGN 01	50	OMT 1023C02	POL-1	4	OMT 1023M05	P - 160								
			05 GT	-	-	1401	140	140	140	115	95	10	100	60	11	M8	90	69	34	AGN 02	50	OMT 1023C02	POL-1	4	OMT 1023G05									
			U 1 P	1402	141	1402	141	140	115	95	10	100	60	11	M8	90	69	34	AGN 03	50	OMT 1023C02	POL-1	4	OMT 1023U1P										
			1 C	1403	142	1403	142	140	115	95	10	100	60	11	M8	90	69	34	AGN 04	50	OMT 1023C02	POL-1	4	OMT 1023C1										
			1 M	1403	142	1403	142	140	115	95	10	100	60	11	M8	90	69	34	AGN 05	50	OMT 1023C02	POL-1	4	OMT 1023M1										
			ZB	-	-	LB18	LBS18	140	115	95	10	100	60	11	M8	90	69	34	AGN 198	50	OMT 1023C02	POL-1	4	OMT 1023ZB										
0,25 ÷ 0,37	71	0,35 ÷ 0,55	05 M	-	-	1601	160	160	160	130	110	10	110	70	14	M8	90	69	34	AGN 1	57	OMT 1030C07	POL-1	4	OMT 1023M05	P - 160								
			05 GT	-	-	1601	160	160	160	130	110	10	110	70	14	M8	90	69	34	AGN 1A	57	OMT 1030C07	POL-1	4	OMT 1023G05									
			U 1 P	1602	161	1602	161	160	130	110	10	110	70	14	M8	90	69	34	AGN 2	57	OMT 1030C07	POL-1	4	OMT 1023U1P										
			1 C	1603	162	1603	162	160	130	110	10	110	70	14	M8	90	69	34	AGN 3	57	OMT 1030C07	POL-1	4	OMT 1023C1										
			1 M	1603	162	1603	162	160	130	110	10	110	70	14	M8	90	69	34	AGN 3A	57	OMT 1030C07	POL-1	4	OMT 1023M1										
			ZB	-	-	LB19	LBS19	160	130	110	10	110	70	14	M8	90	69	34	AGN 199	57	OMT 1030C07	POL-1	4	OMT 1023ZB										
0,55 ÷ 0,75	80	0,75 ÷ 1	05 M	-	-	2101	210	210	200	165	130	12	135	87	15	M10	90	69	34	AGN 4	70	OMT 2033C20	POL-2	4	OMT 2033M05	P - 200 A - 200								
			05 GT	-	-	2101	210	210	200	165	130	12	135	87	15	M10	90	69	34	AGN 4A	70	OMT 2033C20	POL-2	4	OMT 2033G05									
			U 1 P	2102	211	2102	211	200	165	130	12	135	87	15	M10	90	69	34	AGN 5	70	OMT 2033C20	POL-2	4	OMT 2033U1P										
			1 C	2103	212	2103	212	200	165	130	12	135	87	15	M10	90	69	34	AGN 6	70	OMT 2033C20	POL-2	4	OMT 2033C1										
			1 M	2103	212	2103	212	200	165	130	12	135	87	15	M10	90	69	34	AGN 6A	70	OMT 2033C20	POL-2	4	OMT 2033M1										
			ZB	-	-	LB28	LBS28	200	165	130	12	135	87	15	M10	90	69	34	AGN 200	70	OMT 2033C20	POL-2	4	OMT 2033ZB										
			05 M	-	-	2001	200	200	165	130	12	135	95	15	M10	90	69	34	AGN 4	70	OMT 2033C20	POL-2	4	OMT 2033M05										
			05 GT	-	-	2001	200	200	165	130	12	135	95	15	M10	90	69	34	AGN 4A	70	OMT 2033C20	POL-2	4	OMT 2033G05										
			U 1 P	2002	201	2002	201	200	165	130	12	135	95	15	M10	90	69	34	AGN 5	70	OMT 2033C20	POL-2	4	OMT 2033U1P										
			1 C	2003	202	2003	202	200	165	130	12	135	95	15	M10	90	69	34	AGN 6	70	OMT 2033C20	POL-2	4	OMT 2033C1										
			1 M	2003	202	2003	202	200	165	130	12	135	95	15	M10	90	69	34	AGN 6A	70	OMT 2033C20	POL-2	4	OMT 2033M1										
			ZB	-	-	LB20	LBS20	200	165	130	12	135	95	15	M10	90	69	34	AGN 200	70	OMT 2033C20	POL-2	4	OMT 2033ZB										
			2 CA	2004	203	2004	203	200	165	130	12	135	95	15	M10	118	86	43	AGN 7	70	OMT 2033C20	POL-2	4	OMT 2033CA2										
			2 U	2004	203	2004	203	200	165	130	12	135	95	15	M10	118	86	43	AGN 7A	70	OMT 2033C20	POL-2	4	OMT 2033U2										
ZF	-	-	LB21	LBS21	200	165	130	12	135	95	15	M10	118	86	43	AGN 202	70	OMT 2033C20	POL-2	4	OMT 2033ZF													
1,1 ÷ 1,5	90	1,5 ÷ 2	U 1 P	2002	201	2002	201	200	165	130	12	135	95	15	M10	90	69	34	AGN 8	70	OMT 2033C31	POL-2	4	OMT 2033U1P	P - 250 A - 250									
			1 C	2003	202	2003	202	200	165	130	12	135	95	15	M10	90	69	34	AGN 9	70	OMT 2033C31	POL-2	4	OMT 2033C1										
			1 M	2003	202	2003	202	200	165	130	12	135	95	15	M10	90	69	34	AGN 9A	70	OMT 2033C31	POL-2	4	OMT 2033M1										
			ZB	-	-	LB20	LBS20	200	165	130	12	135	95	15	M10	90	69	34	AGN 201	70	OMT 2033C31	POL-2	4	OMT 2033ZB										
			U 1 P	2002	201	2002	201	200	165	130	12	135	95	15	M10	90	69	34	AGN 8	70	OMT 2033C31	POL-2	4	OMT 2033U1P										
			1 C	2003	202	2003	202	200	165	130	12	135	95	15	M10	90	69	34	AGN 9	70	OMT 2033C31	POL-2	4	OMT 2033C1										
			1 M	2003	202	2003	202	200	165	130	12	135	95	15	M10	90	69	34	AGN 9A	70	OMT 2033C31	POL-2	4	OMT 2033M1										
			ZB	-	-	LB20	LBS20	200	165	130	12	135	95	15	M10	90	69	34	AGN 201	70	OMT 2033C31	POL-2	4	OMT 2033ZB										
			2 CA	2004	203	2004	203	200	165	130	12	135	95	15	M10	118	86	43	AGN 10	70	OMT 2033C31	POL-2	4	OMT 2033CA2										
			2 U	2004	203	2004	203	200	165	130	12	135	95	15	M10	118	86	43	AGN 10A	70	OMT 2033C31	POL-2	4	OMT 2033U2										
			ZF	-	-	LB21	LBS21	200	165	130	12	135	95	15	M10	118	86	43	AGN 203	70	OMT 2033C31	POL-2	4	OMT 2033ZF										
			2 CA	2004	203	2004	203	200	165	130	12	135	95	15	M10	118	86	43	AGN 10	70	OMT 2033C31	POL-2	4	OMT 2033CA2										
			2 U	2004	203	2004	203	200	165	130	12	135	95	15	M10	118	86	43	AGN 10A	70	OMT 2033C31	POL-2	4	OMT 2033U2										
			ZF	-	-	LB21	LBS21	200	165	130	12	135	95	15	M10	118	86	43	AGN 203	70	OMT 2033C31	POL-2	4	OMT 2033ZF										
2,2 ÷ 4	100 ÷ 112	3 ÷ 5,5	U 1 P	2501	250	2501	250	250	215	180	14	185	105	21	M12	118	86	43	AGN 11	74	OMT 3040C36	POL-3	4	OMT 3030U1P	P - 250 A - 250									
			1 C	2502	251	2502	251	250	215	180	14	185	105	21	M12	118	86	43	AGN 12	74	OMT 3040C36	POL-3	4	OMT 3030C1										
			1 M	2502	251	2502	251	250	215	180	14	185	105	21	M12	118	86	43	AGN 12A	74	OMT 3040C36	POL-3	4	OMT 3030M1										
			2 CA	2503	252	2503	252	250	215	180	14	185	105	21	M12	118	86	43	AGN 12B	74	OMT 3040C36	POL-3	4	OMT 3030CA2										
			2 U	2503	252	2503	252	250	215	180	14	185	105	21	M12	118	86	43	AGN 12C	74	OMT 3040C36	POL-3	4	OMT 3030U2										
			ZB	-	-	LB22	LBS22	250	215	180	14	185	105	21	M12	118	86	43	AGN 204	74	OMT 3040C36	POL-3	4	OMT 3030ZB										
			ZF	-	-	LB23	LBS23	250	215	180	14	185	105	21	M12	118	86	43	AGN 205	74	OMT 3040C36	POL-3	4	OMT 3030ZF										
			2 CA	2504	253	2504	253	250	215	180	14	185	115	21	M12	170	120	59	AGN 13	84	OMT 3040C36	POL-3	4	OMT 3040CA2										
			2 U	2504	253	2504	253	250	215	180	14	185	115	21	M12	170	120	59	AGN 13A	84	OMT 3040C36	POL-3	4	OMT 3040U2										
			T 250	2505	254	2505	254	250	215	180	14	185	115	21	M12	170	120	59	AGN 14	84	OMT 3040C36	POL-3	4	OMT 3040U3										
			3 U	2506	255	2506	255	250	215	180	14	185	115	21	M12	170	120	59	AGN 14	84	OMT 3040C36	POL-3	4	OMT 3040U3										
			M 3	2507	256	2507	256	250	215	180	14	185	115	21	M12	170	120	59	AGN 14	84	OMT 3040C36	POL-3	4	OMT 3040U3										
			T 3	2508	257	2508	257	250	215	180	14	185	115	21	M12	170	120	59	AGN 14	84	OMT 3040C36	POL-3	4											

MOTORI FLANGIA B3-B5 / MOTORS WITH FLANGE B3-B5

Motore 4 poli 1450 giri/1' Motor power 4 p. 1450 revs/min		Rif. pompa Pump code	Lanterna Bellhousing				Dimensione lanterna (mm) Dimensions of bellhousing (mm)										Giunto completo serie ND Complete coupling ND series	Semigiunto Motore Halfcoupling motor side	Insero elastico Rubber spider	Semigiunto pompa Halfcoupling pump side	Piedino Foot flange	Amm. Anch. Stabilizing ring									
kW	Taglia Size	HP	LE	LSE	L	LS	A	B	C	D	F	G	H	P	Q	R	S	Codice Part number	H	Codice Part number	Codice Part num.	I	Codice Part number	Piedino Foot flange	Amm. Anch. Stabilizing ring						
5,5 ÷ 9	132	7,5 ÷ 12,5	2 CA	3001	300	3001	300	300	265	230	14	235	143	21	M12	170	120	59	AGN 15	104	OMT 4050C47	POL-4	4	OMT 4050CA2	P - 300	A - 300					
			2 U	3001	300	3001	300	300	265	230	14	235	143	21	M12	170	120	59	AGN 15A	104	OMT 4050C47	POL-4	4	OMT 4050U2							
			T 250	3002	301	3002	301	300	265	230	14	235	143	21	M12	170	120	59	AGN 16	104	OMT 4050C47	POL-4	4	OMT 4050U3							
			3 U	3003	302	3003	302	300	265	230	14	235	143	21	M12	170	120	59	AGN 16	104	OMT 4050C47	POL-4	4	OMT 4050U3							
			M 3	3004	303	3004	303	300	265	230	14	235	143	21	M12	170	120	59	AGN 16	104	OMT 4050C47	POL-4	4	OMT 4050U3							
			T 3	3005	304	3005	304	300	265	230	14	235	143	21	M12	170	120	59	AGN 16	104	OMT 4050C47	POL-4	4	OMT 4050U3							
			ZF	-	-	LB26	LBS26	300	265	230	14	235	143	21	M12	170	120	59	AGN 208	104	OMT 4050C47	POL-4	4	OMT 4050ZF							
			ZG	-	-	LB27	LBS27	300	265	230	14	235	143	21	M12	170	120	59	AGN 209	104	OMT 4050C47	POL-4	4	OMT 4050ZG							
			35 M	3006	305	3006	305	300	265	230	14	235	143	21	M12	180	158	62	AGN 17	104	OMT 4050C47	POL-4	4	OMT 4050G35							
			35 G	3007	306	3007	306	300	265	230	14	235	143	21	M12	180	158	62	AGN 17	104	OMT 4050C47	POL-4	4	OMT 4050G35							
			35 U	3007	306	3007	306	300	265	230	14	235	143	21	M12	180	158	62	AGN 18	104	OMT 4050C47	POL-4	4	OMT 4050U35							
			11 ÷ 15	160	15 ÷ 20	2 CA	-	-	3511	350	350	300	250	18	253	178	25	M16	230	175	77	AGN 19	124	OMT 5060C51			POL-5	4	OMT 5060CA2	P - 350	A - 350
						2 U	-	-	3511	350	350	300	250	18	253	178	25	M16	230	175	77	AGN 19A	124	OMT 5060C51			POL-5	4	OMT 5060U2		
						T 250	3512	351	3512	351	350	300	250	18	253	178	25	M16	230	175	77	AGN 20	124	OMT 5060C51			POL-5	4	OMT 5060U3		
3 U	3513	352				3513	352	350	300	250	18	253	178	25	M16	230	175	77	AGN 20	124	OMT 5060C51	POL-5	4	OMT 5060U3							
M 3	3514	353				3514	353	350	300	250	18	253	178	25	M16	230	175	77	AGN 20	124	OMT 5060C51	POL-5	4	OMT 5060U3							
T 3	3515	354				3515	354	350	300	250	18	253	178	25	M16	230	175	77	AGN 20	124	OMT 5060C51	POL-5	4	OMT 5060U3							
ZF	-	-				LB31	LBS31	350	300	250	18	253	178	25	M16	230	175	77	AGN 210	124	OMT 5060C51	POL-5	4	OMT 5060ZF							
ZG	-	-				LB32	LBS32	350	300	250	18	253	178	25	M16	230	175	77	AGN 212	124	OMT 5060C51	POL-5	4	OMT 5060ZG							
35 M	3506	355				-	-	350	300	250	18	253	188	25	M16	230	175	77	AGN 21	124	OMT 5060C51	POL-5	4	OMT 5060G35							
35 G	3507	356				-	-	350	300	250	18	253	188	25	M16	230	175	77	AGN 21	124	OMT 5060C51	POL-5	4	OMT 5060G35							
35 U	3507	356				-	-	350	300	250	18	253	188	25	M16	230	175	77	AGN 22	124	OMT 5060C51	POL-5	4	OMT 5060U35							
4 M	3508	357				-	-	350	300	250	18	253	188	25	M16	230	175	77	AGN 23	124	OMT 5060C51	POL-5	4	OMT 5060M4							
4 T	3508	357				-	-	350	300	250	18	253	188	25	M16	230	175	77	AGN 23	124	OMT 5060C51	POL-5	4	OMT 5060M4							
4 U	3509	358				-	-	350	300	250	18	253	188	25	M16	230	175	77	AGN 24	124	OMT 5060C51	POL-5	4	OMT 5060U4							
18,5 ÷ 22	180	25 ÷ 30	2 CA	-	-	3511	350	350	300	250	18	253	178	25	M16	230	175	77	AGN 25	124	OMT 5060C54	POL-5	4	OMT 5060CA2	P - 350	A - 350					
			2 U	-	-	3511	350	350	300	250	18	253	178	25	M16	230	175	77	AGN 25A	124	OMT 5060C54	POL-5	4	OMT 5060U2							
			T 250	3512	351	3512	351	350	300	250	18	253	178	25	M16	230	175	77	AGN 26	124	OMT 5060C54	POL-5	4	OMT 5060U3							
			3 U	3513	352	3513	352	350	300	250	18	253	178	25	M16	230	175	77	AGN 26	124	OMT 5060C54	POL-5	4	OMT 5060U3							
			M 3	3514	353	3514	353	350	300	250	18	253	178	25	M16	230	175	77	AGN 26	124	OMT 5060C54	POL-5	4	OMT 5060U3							
			T 3	3515	354	3515	354	350	300	250	18	253	178	25	M16	230	175	77	AGN 26	124	OMT 5060C54	POL-5	4	OMT 5060U3							
			ZF	-	-	LB31	LBS31	350	300	250	18	253	178	25	M16	230	175	77	AGN 211	124	OMT 5060C54	POL-5	4	OMT 5060ZF							
			ZG	-	-	LB32	LBS32	350	300	250	18	253	178	25	M16	230	175	77	AGN 213	124	OMT 5060C54	POL-5	4	OMT 5060ZG							
			35 M	3506	355	-	-	350	300	250	18	253	188	25	M16	230	175	77	AGN 27	124	OMT 5060C54	POL-5	4	OMT 5060G35							
			35 G	3507	356	-	-	350	300	250	18	253	188	25	M16	230	175	77	AGN 27	124	OMT 5060C54	POL-5	4	OMT 5060G35							
			35 U	3507	356	-	-	350	300	250	18	253	188	25	M16	230	175	77	AGN 28	124	OMT 5060C54	POL-5	4	OMT 5060U35							
			4 M	3508	357	-	-	350	300	250	18	253	188	25	M16	230	175	77	AGN 29	124	OMT 5060C54	POL-5	4	OMT 5060M4							
			4 T	3508	357	-	-	350	300	250	18	253	188	25	M16	230	175	77	AGN 29	124	OMT 5060C54	POL-5	4	OMT 5060M4							
			4 U	3509	358	-	-	350	300	250	18	253	188	25	M16	230	175	77	AGN 30	124	OMT 5060C54	POL-5	4	OMT 5060U4							
30	200	40	T 250	4001	400	-	-	400	350	300	18	299	188	25	M16	272	247	123	AGN 31	150,5	OMT 6080C56	POL-6	8	OMT 6062U3	A - 400						
			3 U	4002	401	-	-	400	350	300	18	299	188	25	M16	272	247	123	AGN 31	150,5	OMT 6080C56	POL-6	8	OMT 6062U3							
			M 3	4003	402	-	-	400	350	300	18	299	188	25	M16	272	247	123	AGN 31	150,5	OMT 6080C56	POL-6	8	OMT 6062U3							
			T 3	4004	403	-	-	400	350	300	18	299	188	25	M16	272	247	123	AGN 31	150,5	OMT 6080C56	POL-6	8	OMT 6062U3							
			35 M	4005	404	-	-	400	350	300	18	299	188	25	M16	272	247	123	AGN 32	150,5	OMT 6080C56	POL-6	8	OMT 6062G35							
			35 G	4006	405	-	-	400	350	300	18	299	188	25	M16	272	247	123	AGN 32	150,5	OMT 6080C56	POL-6	8	OMT 6062G35							
			35 U	4006	405	-	-	400	350	300	18	299	188	25	M16	272	247	123	AGN 32A	150,5	OMT 6080C56	POL-6	8	OMT 6062U35							
			4 M	4007	406	-	-	400	350	300	18	299	188	25	M16	272	247	123	AGN 33	150,5	OMT 6080C56	POL-6	8	OMT 6062M4							
			4 T	4007	406	-	-	400	350	300	18	299	188	25	M16	272	247	123	AGN 33	150,5	OMT 6080C56	POL-6	8	OMT 6062M4							
			4 U	4008	407	-	-	400	350	300	18	299	188	25	M16	272	247	123	AGN 33A	150,5	OMT 6080C56	POL-6	8	OMT 6062U4							
			ZG	-	-	LB30	LBS30	400	350	300	18	299	188	25	M16	272	247	123	AGN 214	150,5	OMT 6080C56	POL-6	8	OMT 6062ZG							
			37 ÷ 45	225	50 ÷ 60	35 M	-	-	4501*	450*	450	400	350	18	350	218	25	M16	287,5	175	137,5	AGN 34	150,5	OMT 6080C57			POL-6	8	OMT 6062G35	A - 400	
						35 G	-	-	4502*	451*	450	400	350	18	350	218	25	M16	287,5	175	137,5	AGN 34	150,5	OMT 6080C57			POL-6	8	OMT 6062G35		
						35 U	-	-	4502*	451*	450	400	350	18	350	218	25	M16	287,5	175	137,5	AGN 34A	150,5	OMT 6080C57			POL-6	8	OMT 6062U35		
4 M	-	-				4503*	452*	450	400	350	18	350	218	25	M16	287,															

## MOTORI FLANGIA B14 / MOTORS WITH FLANGE B14

Motore 4 poli 1450 giri/1' Motor power 4 p. 1450 revs/min			Rif. pompa Pump code	Lanterna Bellhousing		Dimensione lanterna (mm) Dimensions of bellhousing (mm)										Giunto completo serie ND Complete coupling ND series		Semigiunto Motore Halfcoupling motor side		Inserto elastico Rubber spider		Semigiunto pompa Halfcoupling pump side		Piedino Foot flange	Anello amm. Damping ring
kW	Taglia Size	HP	L	LS	A	B	C	D	F	G	H	P	Q	R	S	Codice Part number	H	Codice Part number	Codice Part num.	I	Codice Part number				
0,12 ÷ 0,18	63	0,16 ÷ 0,25	<b>0,5M</b>	<b>901</b>	-	90	75	60	6,5	62	60	10	-	90	69	34	<b>ND 01</b>	54	ND 48A	R-42	16	ND 48P05M			
			<b>0,5GT</b>	<b>901</b>	-	90	75	60	6,5	62	60	10	-	90	69	34	<b>ND 02</b>	54	ND 48A	R-42	16	ND 48P05GT			
			<b>U1P</b>	<b>902</b>	-	90	75	60	6,5	62	60	10	-	90	69	34	<b>ND 03</b>	52	ND 48A	R-42	16	ND 48PU1P			
			<b>1C</b>	<b>903</b>	-	90	75	60	6,5	62	60	10	-	90	69	34	<b>ND 04</b>	52	ND 48A	R-42	16	ND 48P1C			
			<b>1M</b>	<b>903</b>	-	90	75	60	6,5	62	60	10	-	90	69	34	<b>ND 05</b>	52	ND 48A	R-42	16	ND 48P1M			
			<b>ZB</b>	<b>LB 9</b>	-	90	75	60	6,5	62	60	10	-	90	69	34	<b>ND 198</b>	52	ND 48A	R-42	16	ND 48PZB			
0,25 ÷ 0,37	71	0,35 ÷ 0,55	<b>0,5M</b>	<b>1051</b>	-	105	85	70	7	70	70	10	-	90	69	34	<b>ND 1</b>	64	ND 48B	R-42	16	ND 48P05M			
			<b>0,5GT</b>	<b>1051</b>	-	105	85	70	7	70	70	10	-	90	69	34	<b>ND 1A</b>	64	ND 48B	R-42	16	ND 48P05GT			
			<b>U1P</b>	<b>1052</b>	-	105	85	70	7	70	70	10	-	90	69	34	<b>ND 2</b>	62	ND 48B	R-42	16	ND 48PU1P			
			<b>1C</b>	<b>1053</b>	-	105	85	70	7	70	70	10	-	90	69	34	<b>ND 3</b>	62	ND 48B	R-42	16	ND 48P1C			
			<b>1M</b>	<b>1053</b>	-	105	85	70	7	70	70	10	-	90	69	34	<b>ND 3A</b>	62	ND 48B	R-42	16	ND 48P1M			
			<b>ZB</b>	<b>LB 10</b>	-	105	85	70	7	70	70	10	-	90	69	34	<b>ND 199</b>	62	ND 48B	R-42	16	ND 48PZB			
0,55 ÷ 0,75	80	0,75 ÷ 1	<b>0,5M</b>	<b>1201</b>	-	120	100	80	7	80	85	12	-	120	90	45	<b>ND 4B</b>	80	ND 48CG45	R-42	16	ND 48P05M			
			<b>0,5GT</b>	<b>1201</b>	-	120	100	80	7	80	85	12	-	120	90	45	<b>ND 4C</b>	80	ND 48CG45	R-42	16	ND 48P05GT			
			<b>U1P</b>	<b>1202</b>	-	120	100	80	7	80	85	12	-	120	90	45	<b>ND 5A</b>	98	ND 48CG45	R-42	16	ND 48PU1P			
			<b>1C</b>	<b>1203</b>	-	120	100	80	7	80	85	12	-	120	90	45	<b>ND 6B</b>	78	ND 48CG45	R-62	18	ND 48P1C			
			<b>1M</b>	<b>1203</b>	-	120	100	80	7	80	85	12	-	120	90	45	<b>ND 6C</b>	78	ND 48CG45	R-62	18	ND 48P1M			
			<b>ZB</b>	<b>LB 11</b>	-	120	100	80	7	80	85	12	-	120	90	45	<b>ND 300</b>	78	ND 48CG45	R-62	18	ND 48PZB			
			<b>2</b>	<b>1204</b>	-	120	100	80	7	80	85	12	-	120	90	45	<b>ND 7B</b>	77,5	ND 65AG38	R-62	18	ND 65P2			
			<b>ZF</b>	<b>LB 12</b>	-	120	100	80	7	80	85	12	-	120	90	45	<b>ND 207</b>	77,5	ND 65AG38	R-62	18	ND 65PZF			
1,1 ÷ 1,5	90	1,5 ÷ 2	<b>U1P</b>	<b>1410</b>	<b>149</b>	140	115	95	9,5	100	95	12	M8	120	90	45	<b>ND 8</b>	87	ND 65B	R-62	18	ND 65PU1P			
			<b>1C</b>	<b>1411</b>	<b>150</b>	140	115	95	9,5	100	95	12	M8	120	90	45	<b>ND 9</b>	87	ND 65B	R-62	18	ND 65P1C			
			<b>1M</b>	<b>1411</b>	<b>150</b>	140	115	95	9,5	100	95	12	M8	120	90	45	<b>ND 9A</b>	87	ND 65B	R-62	18	ND 65P1M			
			<b>ZB</b>	<b>LB 40</b>	<b>LBS 40</b>	140	115	95	9,5	100	95	12	M8	120	90	45	<b>ND 201</b>	87	ND 65B	R-62	18	ND 65PZB			
			<b>2</b>	<b>1409</b>	<b>148</b>	140	115	95	9,5	100	95	12	M8	120	90	45	<b>ND 10</b>	87	ND 65B	R-62	18	ND 65P2			
			<b>ZF</b>	<b>LB 14</b>	<b>LBS 14</b>	140	115	95	9,5	100	95	12	M8	120	90	45	<b>ND 203</b>	87	ND 65B	R-62	18	ND 65PZF			
2,2 ÷ 4	100 ÷ 112	3 ÷ 5,5	<b>U1P</b>	<b>1610</b>	<b>169</b>	160	130	110	9,5	114	105	14	M8	120	90	45	<b>ND 11</b>	97	ND 65C	R-62	18	ND 65PU1P			
			<b>1C</b>	<b>1611</b>	<b>170</b>	160	130	110	9,5	114	105	14	M8	120	90	45	<b>ND 12</b>	97	ND 65C	R-62	18	ND 65P1C			
			<b>1M</b>	<b>1611</b>	<b>170</b>	160	130	110	9,5	114	105	14	M8	120	90	45	<b>ND 12A</b>	97	ND 65C	R-62	18	ND 65P1M			
			<b>ZB</b>	<b>LB 17</b>	<b>LBS 17</b>	160	130	110	9,5	114	105	14	M8	120	90	45	<b>ND 204</b>	97	ND 65C	R-62	18	ND 65PZB			
			<b>2</b>	<b>1609</b>	<b>168</b>	160	130	110	9,5	114	105	14	M8	120	90	45	<b>ND 13</b>	97	ND 65C	R-62	18	ND 65P2			
			<b>ZF</b>	<b>LB 16</b>	<b>LBS 16</b>	160	130	110	9,5	114	105	14	M8	120	90	45	<b>ND 206</b>	97	ND 65C	R-62	18	ND 65PZF			
5,5 ÷ 7,5	132	7,5 ÷ 10	<b>2</b>	<b>2015</b>	-	200	165	130	11,5	137	139	16	-	150	132	72	<b>ND 16B</b>	127	ND 86BG80	R-82	20	ND 86P2			
			<b>ZF</b>	<b>LB 41</b>	-	200	165	130	11,5	137	139	16	-	150	132	72	<b>ND 311</b>	127	ND 86BG80	R-82	20	ND 86PZF			
			<b>T250</b>	<b>2016</b>	-	200	165	130	11,5	137	139	16	-	150	132	72	<b>ND 17A</b>	127	ND 86BG80	R-82	20	ND 86P3U			
			<b>3U</b>	<b>2017</b>	-	200	165	130	11,5	137	139	16	-	150	132	72	<b>ND 17A</b>	127	ND 86BG80	R-82	20	ND 86P3U			
			<b>M3</b>	<b>2018</b>	-	200	165	130	11,5	137	139	16	-	150	132	72	<b>ND 17A</b>	127	ND 86BG80	R-82	20	ND 86P3U			
			<b>T3</b>	<b>2019</b>	-	200	165	130	11,5	137	139	16	-	150	132	72	<b>ND 17A</b>	127	ND 86BG80	R-82	20	ND 86P3U			
			<b>ZG</b>	<b>LB 42</b>	-	200	165	130	11,5	137	139	16	-	150	132	72	<b>ND 312</b>	127	ND 86BG80	R-82	20	ND 86PZG			

FLANGIA / FLANGE

tipo / series **B14**

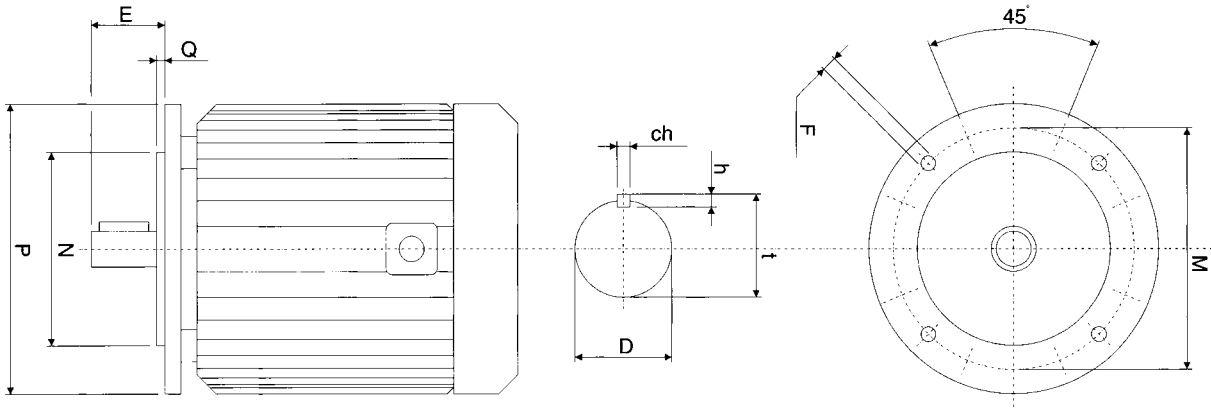

Taglia Size	Potenza / Motor power								Dimensioni / Dimensions									
	2 poli / 2 poles		4 poli / 4 poles		6 poli / 6 poles		8 poli / 8 poles		Dimensioni flangia / Flange dimensions					Dimensioni albero / Shaft dimensionst				
	2900 giri/min - revs/min		1450 giri/min - revs/min		960 giri/min - revs/min		720 giri/min - revs/min		P	M	N	Q	F	D	E	ch	h	t
<b>63</b>	0,18	0,24	0,12	0,16					90	75	60	2,5	M5	11	23	4	4	12,5
	0,25	0,35	0,185	0,25														
<b>71</b>	0,37	0,55	0,25	0,35					105	85	70	2,5	M6	14	30	5	5	16
	0,55	0,75	0,37	0,55														
<b>80</b>	0,75	1	0,55	0,75	0,37	0,5			120	100	80	3	M6	19	40	6	6	21,5
	1,1	1,5	0,75	1	0,55	0,75												
<b>90S</b>	1,5	2	1,1	1,5	0,75	1			140	115	95	3	M8	24	50	8	7	27
<b>90L</b>	2,2	3	1,5	2	1,1	1,5			140	115	95	3	M8	24	50	8	7	27
<b>100L</b>	3	4	2,2	3	1,5	2	0,75	1	160	130	110	3,5	M8	28	60	8	7	31
			3	4			1,1	1,5										
<b>112M</b>	4	5,5	4	5,5	2,2	3	1,5	2	160	130	110	3,5	M8	28	60	8	7	31
<b>132S</b>	7,5	10	5,5	7,5	3	4	2,2	3	200	165	130	3,5	M10	38	80	10	8	41
<b>132M</b>	9	12,5	7,5	10	5,5	7,5	3	4	200	165	130	3,5	M10	38	80	10	8	41



OMT Group S.p.A.  
Via Lombardia, 14  
24040 Calvenzano (BG) - Italy  
Tel.: +39 0363 86.03.11  
Fax: +39 0363 33.56.20

 [www.omtgroup.it](http://www.omtgroup.it)

 [omtgroup@omtgroup.it](mailto:omtgroup@omtgroup.it)

    OMT Group

