



OIL SOLUTIONS

PO Box 38
Strathfieldsaye, VIC, 3551
1800 OIL SOL
1800 645 765
sales@oilsolutions.com.au
www.oilsolutions.com.au
"For All Your Hydraulic Needs"



POMPE E MOTORI IN ALLUMINIO SERIE Z2
ALUMINIUM PUMPS AND MOTORS Z2 SERIES



Caratteristiche principali

- ◆ Coperchi in ghisa per elevate prestazioni.
- ◆ Possibilità di funzionare ad alte pressioni: fino a 300 bar di pressione massima in funzionamento continuo.
- ◆ Compensazione assiale per il recupero dei giochi
- ◆ Alto rendimento volumetrico: 95-97% medio.
- ◆ Ampia disponibilità di cilindrata: 4-6-8-11-14-17-20-25-31 cm³/giro.
- ◆ Corpo in alluminio estruso
- ◆ Progetto accurato del profilo del dente per avere una bassa rumorosità.
- ◆ Vasta gamma di flange, alberi e connessioni compatibili con i principali standard del mercato.
- ◆ Disponibilità di guarnizioni per alte temperature
- ◆ Pompe e motori unidirezionali
- ◆ Pompe e motori bidirezionali
- ◆ Possibilità di montaggio di pompe multiple sia nelle serie in alluminio che con altre serie in ghisa prodotte dalla Ronzio Oleodinamica
- ◆ Facilità di trasformazione: da pompa singola in pompa multipla e di cambio rotazione.

Main Features

- ◆ *Cast iron covers for high performances*
- ◆ *High pressure option: up to 300 bar max. continuous pressure (4350 psi)*
- ◆ *Axial compensation achieved using pressure balanced bushing blocks.*
- ◆ *High volumetric efficiency: average 95-97%*
- ◆ *Wide range of capacities : 4-6-8-11-14-17-20-25-31-cm³/rev.*
- ◆ *Extruded aluminium body*
- ◆ *Gear tooth profile accurately projected providing low noise operation.*
- ◆ *A wide variety of shafts, flanges and ports are available to meet specific application requirements.*
- ◆ *High-temperature seals available.*
- ◆ *Single rotational pumps and motors.*
- ◆ *Bi-rotational pumps and motors.*
- ◆ *Multiple pumps availability: tandem pumps are possible both in aluminium series and with other cast iron series by Ronzio Oleodinamica*
- ◆ *Easy-to-make tandem pumps and easy change of rotation.*

CONDIZIONI PER L'UTILIZZO DELLE POMPE E MOTORI "Z2"

CONDITIONS OF USE FOR PUMPS AND MOTORS "Z2"

Nell'utilizzo della pompa evitare carichi radiali e assiali sull'albero.

Il giunto di trascinamento deve compensare eventuali errori di allineamento , deve essere di tipo elastico oppure di tipo Oldham.

Per un corretto funzionamento e una lunga durata della pompa, osservare i valori riportati nella tabella seguente.

Avoid radial and axial loads on the pump shaft during the use.

The pump must be in line with the P.T.O. To compensate misalignment errors, use flexible or "Oldham" coupling.

We recommend to read the specifications in this catalogue very carefully. This will help you in getting the best, in terms of working conditions and life, from Ronzio gear pumps.

CONDIZIONI DI L'UTILIZZO

USE CONDITIONS

Fluidi idraulici <i>Hydraulic fluids</i>	Oli idraulici a base minerale (DIN 51524) Per utilizzo di fluidi non infiammabili come acqua e glicole , emulsione di olio in acqua, o esteri fosforici, contattare il nostro ufficio tecnico o commerciale <i>Mineral oil (DIN 51524)</i> <i>For use with fire resistant fluids like water glycol, water- oil emulsion and phosphate-esters, contact our technical or commercial office.</i>		
Pressione in aspirazione <i>Inlet pressure</i>	0.7 - 3 bar (Assoluti / Absolute) 10 - 44 psi (Assoluti / Absolute)		
Velocità olio nella linea di aspirazione <i>Oil speed on suction line</i>	0.5 ÷ 1.5 m/s		
Velocità olio nella linea di mandata <i>Oil speed on pressure line</i>	6 ÷ 10 m/s		
Temperatura olio <i>Oil temperature</i>	-10°C ÷ 80°C		
Viscosità olio <i>Oil viscosity</i>	20 ÷ 120 mm ² / s (Cst)		
Massima viscosità olio all'avvio <i>Max starting viscosity</i>	700 mm ² / s (Cst)		
Filtraggio olio <i>Oil filtration</i>	Pressione <i>Pressure</i>	< 200 bar	> 200 bar
	Classe di contaminazione NAS 1638 <i>Contamination class NAS 1638</i>	10	9
	Classe di contaminazione ISO 4406 <i>Contamination class ISO 4406</i>	19/16	18/15
	Rapporto β _x ≥ 75 Ratio β _x ≥ 75	25µm	10µm

FORMULE PER DIMENSIONAMENTO

DETERMINATION OF NOMINAL SIZE

PER POMPE
FOR PUMP

$$Q = \frac{V * \eta_v * n}{1000}$$

$$M = \frac{p * V}{62.8 * \eta_m}$$

$$P = \frac{p * Q}{600 * \eta_t}$$

PER MOTORI
FOR MOTOR

$$Q = \frac{V * n}{1000 * \eta_v}$$

$$M = \frac{p * V * \eta_m}{62.8}$$

$$P = \frac{p * Q * \eta_t}{600}$$

V [cm³]
Q [l/min]
p [bar]
M [Nm]
n [min⁻¹]
P [Kw]

η_v = EFF vol. ≥ 95
η_m = EFF mecc. ~ 0.85

η_t = η_v * η_m. ~ 0.8

CARATTERISTICHE PRINCIPALI

MAIN CHARACTERISTICS

Tipo - Type		04	06	08	11	14	17	20	25	31
Cilindrata Capacity	Cm ³ / giro Cm ³ / rev	4.4	6.28	8.16	11.3	14.45	16.95	20.1	25.75	31.4
P1 Pressione max continua Max working pressure	Bar	300	300	300	300	300	270	230	180	160
P2 Pressione intermittente intermittent pressure	Bar	340	310	310	310	300	270	240	200	170
P3 Pressione max di picco Max peak pressure	Bar	360	360	360	360	360	330	290	230	200
Velocità max per pressione P1 Max speed for P1 pressure	Giri / min Rpm	4500	4500	3700	3300	2700	2500	2500	2500	2200
Velocità max a vuoto Max speed without load	Giri / min Rpm	5500	5500	4700	4000	3300	3000	3000	3000	2700
Velocità min. per pressione P1 Min speed for P1 pressure	Giri / min Rpm	1000	700	550	450	400	350	300	250	200

VERIFICARE, ATTRAVERSO LE FORMULE A PAG. 4, LA COMPATIBILITA' TRA LE PRESTAZIONI DI PRESSIONE E PORTATA RICHIESTE E LA CAPACITA' DELL' ALBERO DI TRASCINAMENTO DI SOPPORTARE LA COPPIA RICHIESTA

VERIFY THE COMPATIBILITY AMONG PERFORMANCE OF PRESSURE, FLOW REQUIRED AND TORQUE OF THE SHAFT THROUGH THE FORMULAS ON PAG. 4

Per pompe o motori bidirezionali, diminuire la pressione del 15%
With bidirectional pumps or motors, pressure is reduced by 15%

COMPONENTI
PARTS

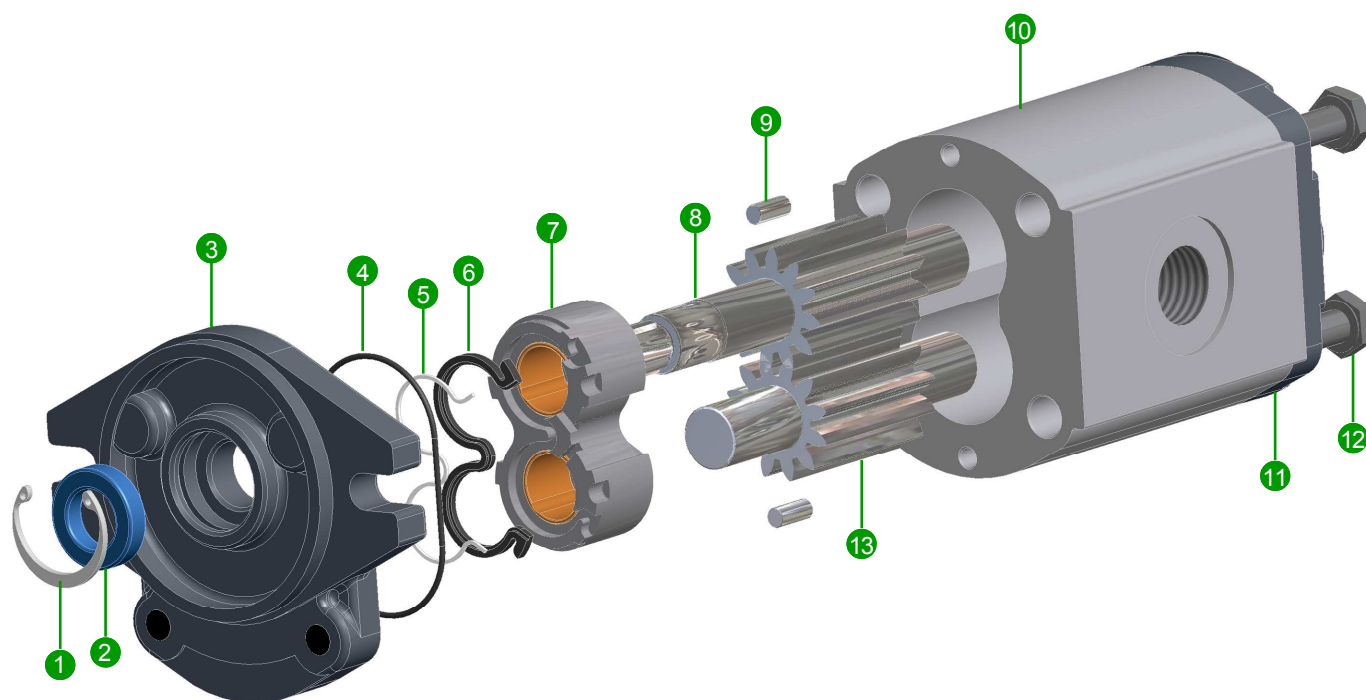

Rif.	Descrizione	Description	Qt.
1	Anello elastico	Snap ring	1
2	Anello di tenuta	Rotary shaft seal	1
3	Flangia	Front flange	1
4	Guarnizione sotto-coperchio	Under cover seal	2
5	Antiestrusore	Seal against extruding	2
6	Guarnizione di compensazione	Compensation seal	2
7	Rasamento	Bushing block	2
8	Ingranaggio conduttore	Drive gear	1
9	Spina cilindrica	Pin	4
10	Corpo	Housing	1
11	Coperchio	Rear cover	1
12	Vite	Bolt	4
13	Ingranaggio condotto	Idle gear	1

SENSO DI ROTAZIONE
ROTATION

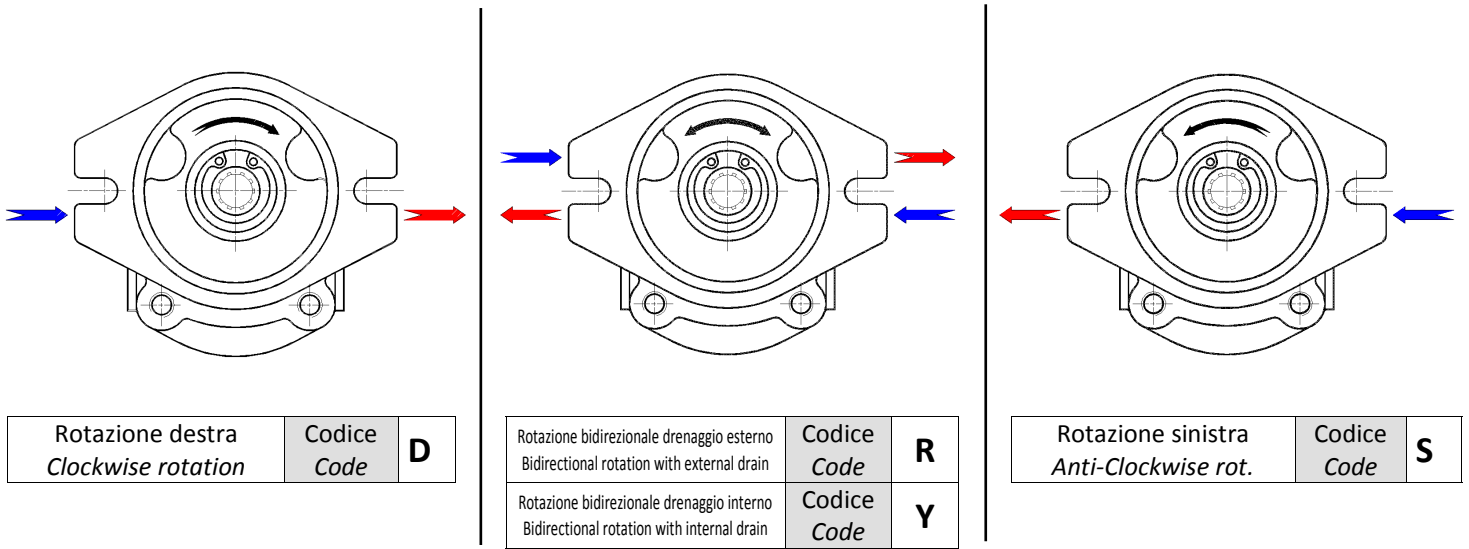

GUARNIZIONI PER ALBERI
SHAFT SEAL

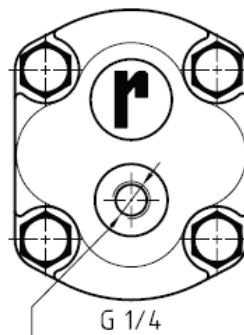
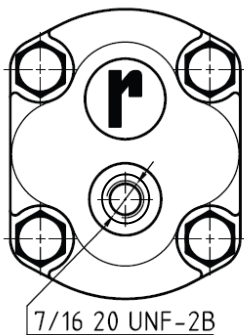
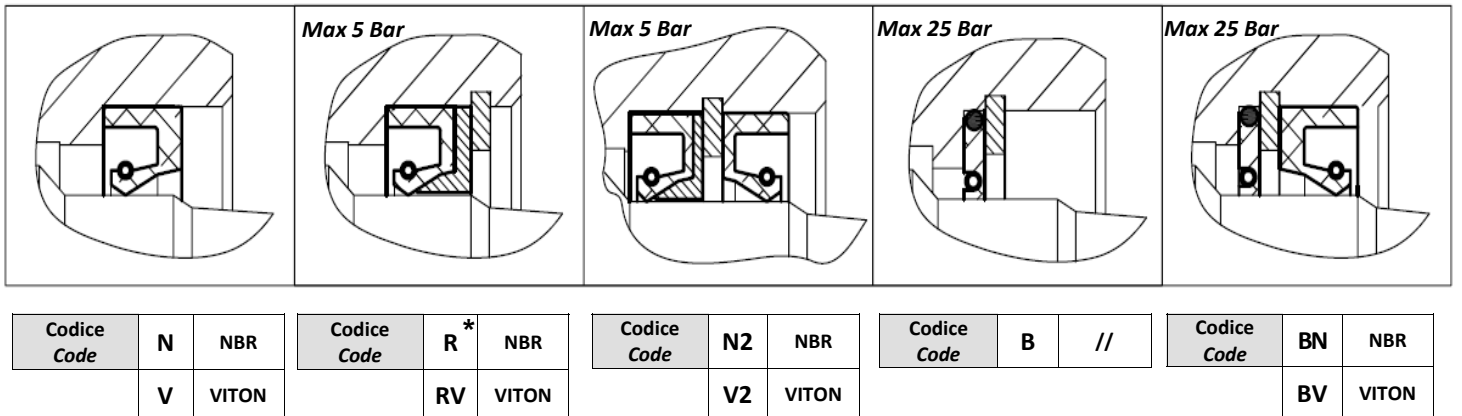

Drenaggio per pompe con flange
Drain for pumps with flanges

C4 - H6 - C7

Drenaggio per pompe con flange
Drain for pumps with flanges

A0 - B1 - D3 - D2 - M3 - M2 - E2 - F5 - L3

il codice "R" comprende rotazione bidirezionale, paraolio rinforzato 5 bar e drenaggio posteriore
Code "R" means bidirectional rotation, reinforced shaft seal 5 bar and rear drain

CAMBIO DEL SENSO DI ROTAZIONE DELLE POMPE Z2 CHANGING ROTATION OF THE PUMP Z2

Rotazione sinistra
Anticlockwise rotation

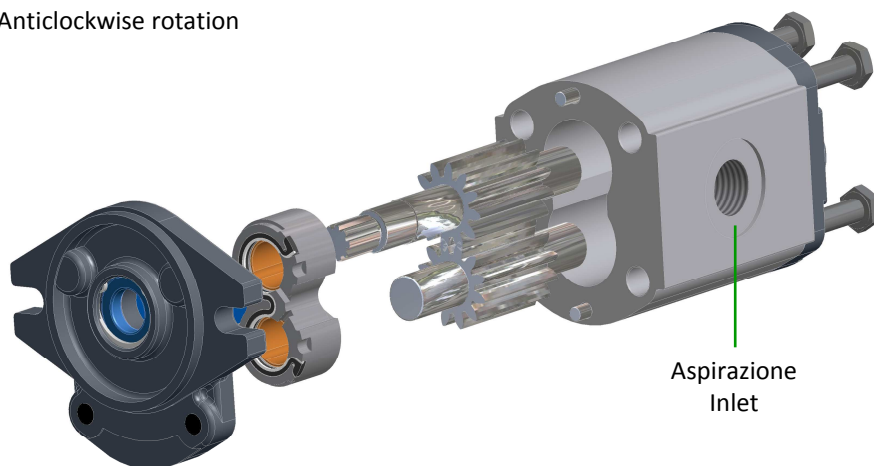

Rotazione destra
Clockwise rotation

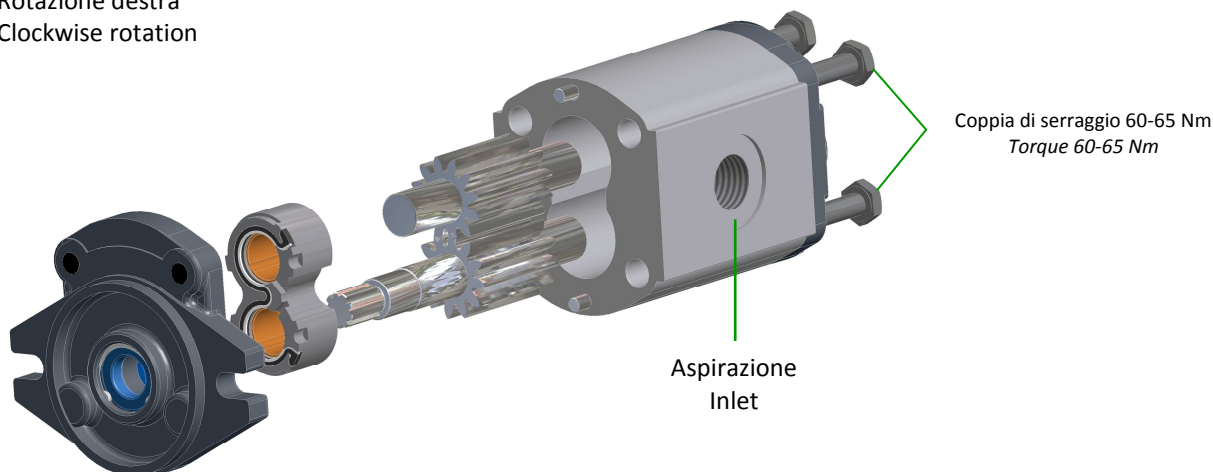

Il senso di rotazione, è indicato con una freccia sul corpo della pompa.
An arrow on the housing of the pump indicates the rotation.

- Svitare le viti di fissaggio.
- Rimuovere la flangia tenendo premuto l'ingranaggio conduttore.
- Rimuovere contemporaneamente l'ingranaggio conduttore e il rasamento superiore mantenendo premuto l'ingranaggio condotto.
- Estrarre l'ingranaggio condotto tenendo fermo il rasamento inferiore, nel caso aiutarsi con una barretta NON metallica.
- Rimontare i due ingranaggi con posizioni invertite (vedi schema sopra).
- Rimontare il rasamento superiore facendo attenzione a NON invertirne la posizione.
- Rimontare la flangia utilizzando per le viti una coppia di serraggio di 60-65 Nm.

-
- *Unscrew the clamping bolts.*
 - *Remove the flange holding down the drive gear.*
 - *Remove the drive gear and the bushing block holding down the idle gear.*
 - *Remove the idle gear keeping down the rear bushing block with a no-metallic bar.*
 - *Reverse the position of the two gears (see picture above)*
 - *Replace the bushing block without rotating or changing position.*
 - *Reverse the flange and retighten the bolts to a torque rating between 44-48 ft/lbs*

FLANGE
FLANGES

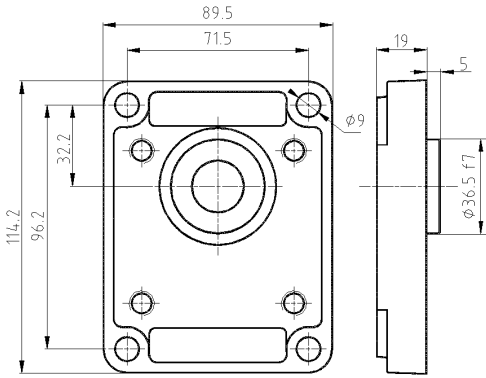

CODICE CODE	A	0
------------------------------	----------	----------

NOTA : Materiale Ghisa
NOTE : Material Cast iron

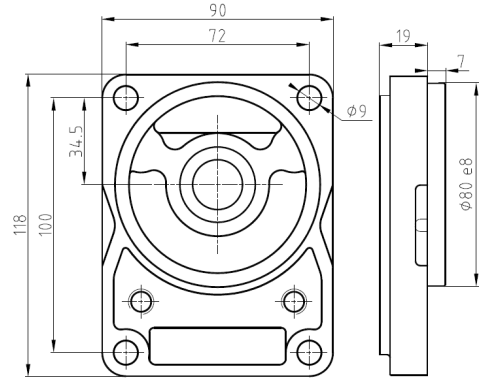

CODICE CODE	B	1
------------------------------	----------	----------

NOTA : Materiale Ghisa
NOTE : Material Cast iron

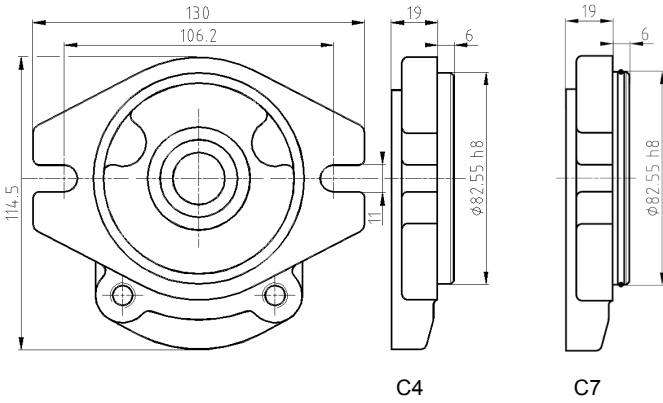

C4 C7

CODICE CODE	C	4
	C	7

NOTA : Materiale Ghisa
NOTE : Material Cast iron

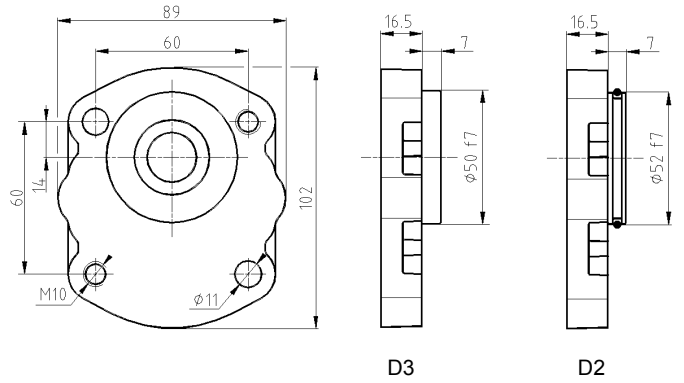

D3 D2

CODICE CODE	D	3
	D	2

NOTA : Materiale Ghisa
NOTE : Material Cast iron

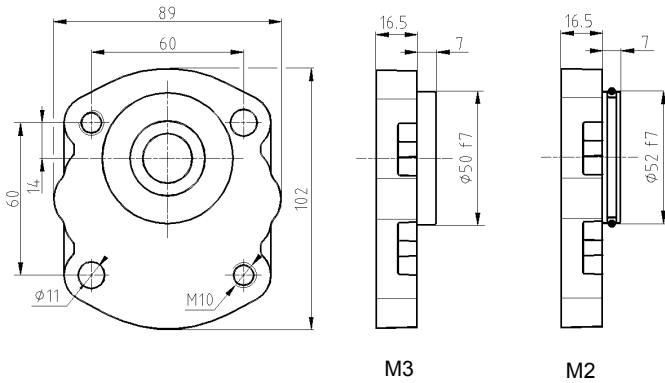

M3 M2

CODICE CODE	M	3
	M	2

NOTA : Materiale Ghisa
NOTE : Material Cast iron

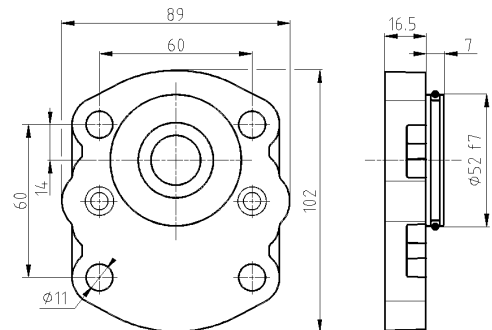

CODICE CODE	E	2
------------------------------	----------	----------

NOTA : Materiale Ghisa
NOTE : Material Cast iron

FLANGE
FLANGES

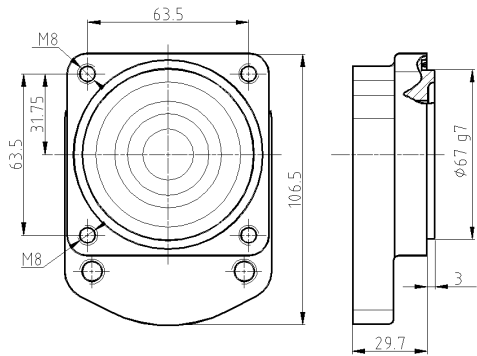

CODICE CODE	F	5
------------------------------	----------	----------

NOTA : Materiale Ghisa
NOTE : Material Cast iron

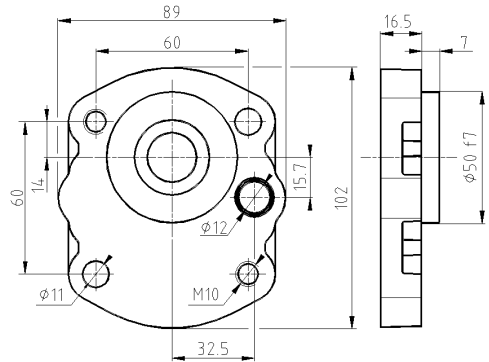

CODICE CODE	G	3
------------------------------	----------	----------

NOTA : Materiale Ghisa
NOTE : Material Cast iron

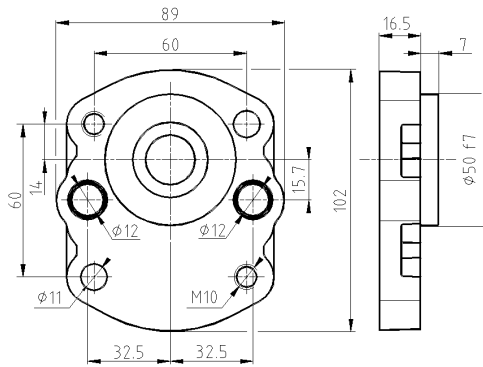

CODICE CODE	L	3
------------------------------	----------	----------

NOTA : Materiale Ghisa
NOTE : Material Cast iron

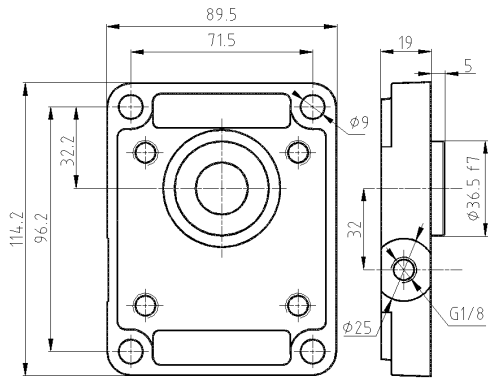

CODICE CODE	N	4
------------------------------	----------	----------

NOTA : Materiale Ghisa
NOTE : Material Cast iron

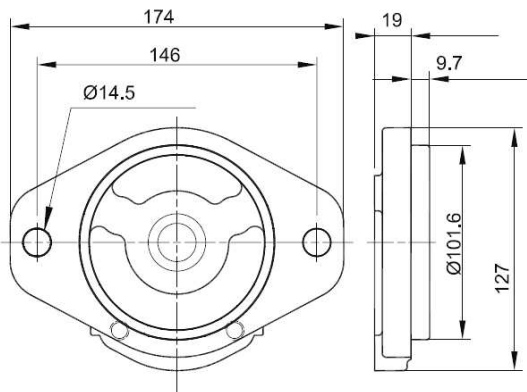

CODICE CODE	H	6
------------------------------	----------	----------

NOTA : Materiale Ghisa
NOTE : Material Cast iron

ALBERI
SHAFTS

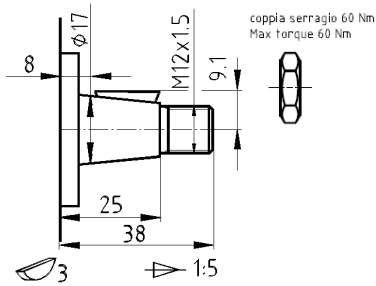

CODICE / CODE	A	
PER FLANGIA / FOR FLANGE	B	1

Coppia max 140 Nm
Max torque 140 Nm

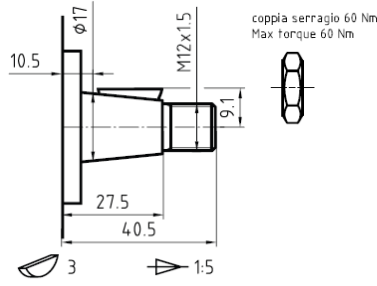

CODICE / CODE	A	
PER FLANGIA / FOR FLANGE	D	3
	L	3
	M	3

Coppia max 140 Nm
Max torque 140 Nm

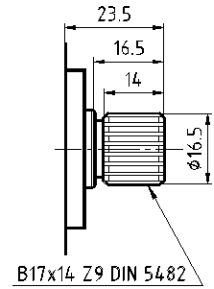

CODICE / CODE	B	
PER FLANGIA / FOR FLANGE	B	1

Coppia max 110 Nm
Max torque 110 Nm

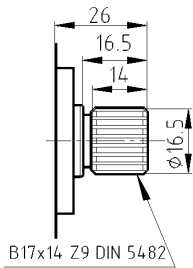

CODICE / CODE	B	
PER FLANGIA / FOR FLANGE	D	3
	L	3
	M	3

Coppia max 110 Nm
Max torque 110 Nm

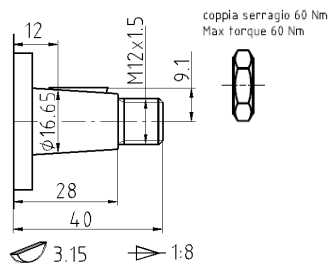

CODICE / CODE	C	
PER FLANGIA / FOR FLANGE	A	0

Coppia max 150 Nm
Max torque 150 Nm

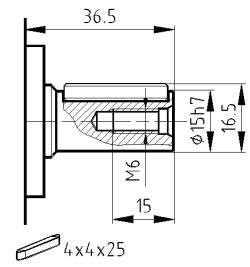

CODICE / CODE	E	
PER FLANGIA / FOR FLANGE	A	0

Coppia max 70 Nm
Max torque 70 Nm

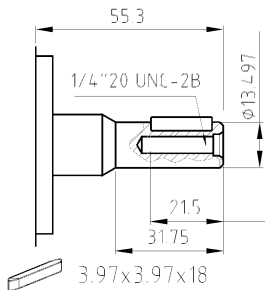

CODICE / CODE	H	
PER FLANGIA / FOR FLANGE	C	4

Coppia max 60 Nm
Max torque 60 Nm

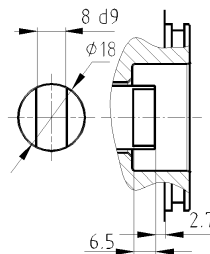

CODICE / CODE	F	
PER FLANGIA / FOR FLANGE	E	2

Coppia max 75 Nm
Max torque 75 Nm

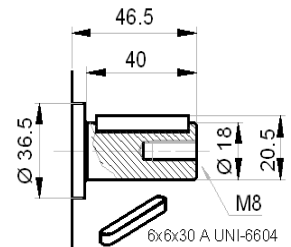

SOLO CON SUPPORTI INTEGRATI TIPO 1
WITH OUTBOARD BEARING TYPE 1

CODICE / CODE	G	
PER FLANGIA / FOR FLANGE	A	0

Coppia max 100 Nm
Max torque 100 Nm

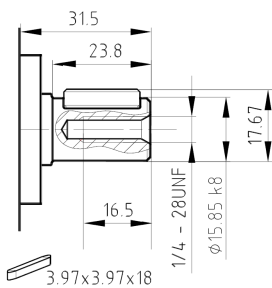

CODICE / CODE	L	
PER FLANGIA / FOR FLANGE	C	4

Coppia max 75 Nm
Max torque 75 Nm

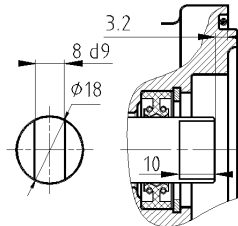

CODICE / CODE	M	
PER FLANGIA / FOR FLANGE	F	5

Coppia max 75 Nm
Max torque 75 Nm

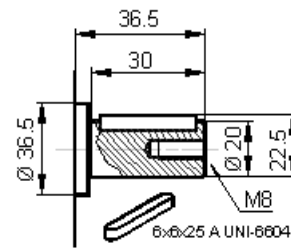

SOLO CON SUPPORTI INTEGRATI TIPO 1
WITH OUTBOARD BEARING TYPE 1

CODICE / CODE	I	
PER FLANGIA / FOR FLANGE	A	0

Coppia max 100 Nm
Max torque 100 Nm

ALBERI
SHAFTS

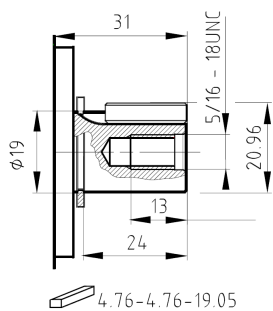

4.76-4.76-19.05

CODICE / CODE	N	
PER FLANGIA / FOR FLANGE	C	4
	C	7
	H	6

Coppia max 110 Nm
Max torque 110 Nm

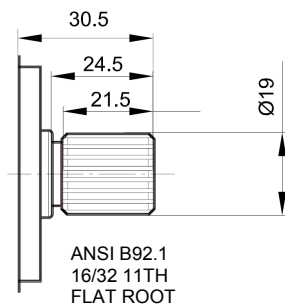

CODICE / CODE	P	
PER FLANGIA / FOR FLANGE	C	2
	C	4

Coppia max 170 Nm
Max torque 170 Nm

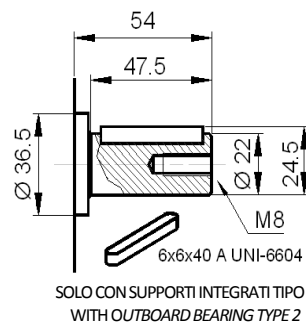

CODICE / CODE	Q	
PER FLANGIA / FOR FLANGE	A	0

Coppia max 110 Nm
Max torque 110 Nm

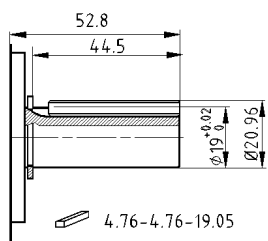

CODICE / CODE	R	
PER FLANGIA / FOR FLANGE	C	4
	C	7
	H	6

Coppia max 140 Nm
Max torque 140 Nm

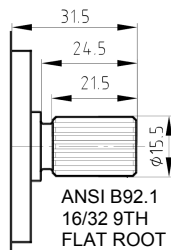

CODICE / CODE	S	
PER FLANGIA / FOR FLANGE	C	4
	C	7
	H	6

Coppia max 100 Nm
Max torque 100 Nm

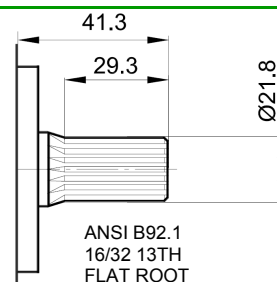

CODICE / CODE	T	
PER FLANGIA / FOR FLANGE	C	4
	C	7
	H	6

Coppia max 280 Nm
Max torque 280 Nm

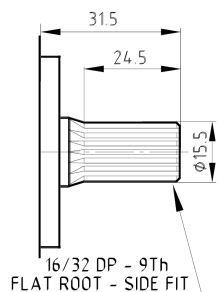

CODICE / CODE	U	
PER FLANGIA / FOR FLANGE	C	4
	C	7
	H	6

Coppia max 130 Nm
Max torque 130 Nm

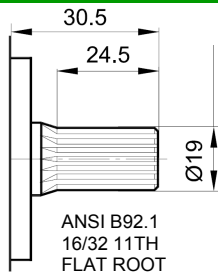

CODICE / CODE	K	
PER FLANGIA / FOR FLANGE	C	4
	C	7
	H	6

Coppia max 200 Nm
Max torque 200 Nm

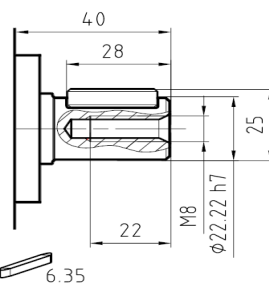

CODICE / CODE	V	
PER FLANGIA / FOR FLANGE	C	4
	C	7
	H	6

Coppia max 190 Nm
Max torque 190 Nm

BOCCHIE DI ASPIRAZIONE E MANDATA LATERALI
SIDE INLET AND OUTLET PORTS

ASPIRAZIONE INLET	MANDATA OUTLET
------------------------------------	---------------------------------

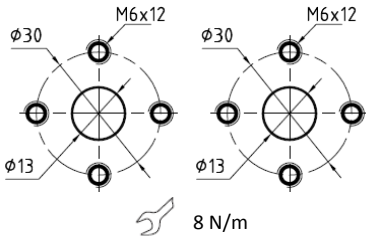

CODICE CODE	32
------------------------------	-----------

ASPIRAZIONE INLET	MANDATA OUTLET
------------------------------------	---------------------------------

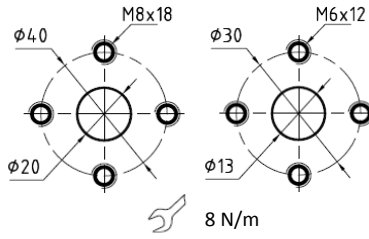

CODICE CODE	33
------------------------------	-----------

ASPIRAZIONE INLET	MANDATA OUTLET
------------------------------------	---------------------------------

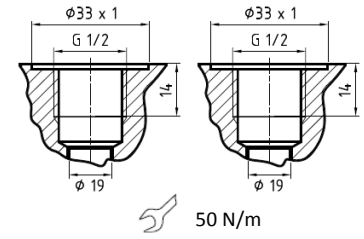

CODICE CODE	34
------------------------------	-----------

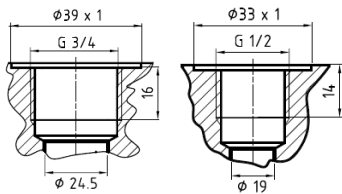

CODICE CODE	35
------------------------------	-----------

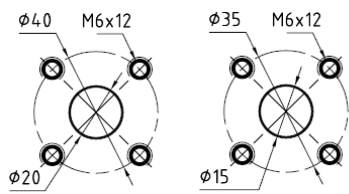

CODICE CODE	36
------------------------------	-----------

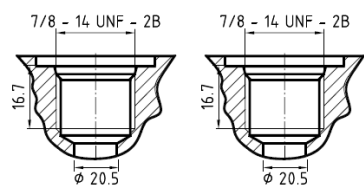

CODICE CODE	37
------------------------------	-----------

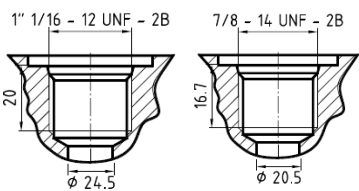

CODICE CODE	38
------------------------------	-----------

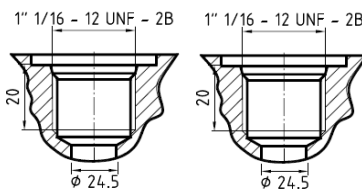

CODICE CODE	39
------------------------------	-----------

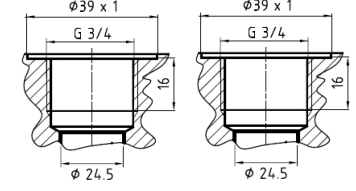

CODICE CODE	41
------------------------------	-----------

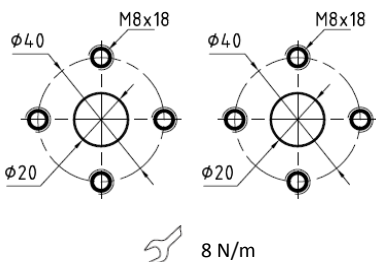

CODICE CODE	43
------------------------------	-----------

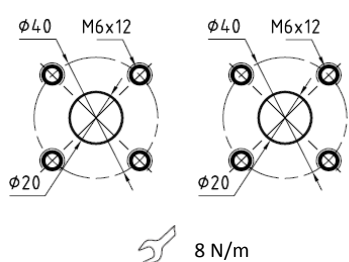

CODICE CODE	44
------------------------------	-----------

BOCCHIE DI ASPIRAZIONE E MANDATA ANTERIORI / POSTERIORI
FRONT AND REAR INLET AND OUTLET PORTS

ASPIRAZIONE INLET	MANDATA OUTLET
MANDATA OUTLET	ASPIRAZIONE INLET

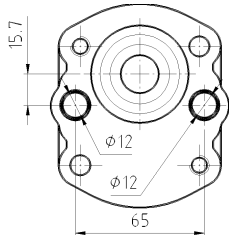

CODICE CODE	49
----------------	-----------

ASPIRAZIONE INLET	MANDATA OUTLET
----------------------	-------------------

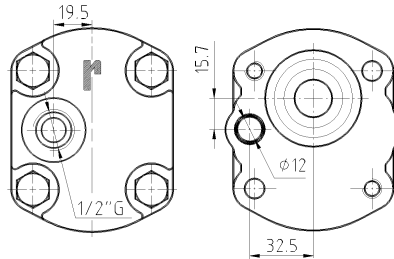

CODICE CODE	50
----------------	-----------

ASPIRAZIONE INLET	MANDATA OUTLET
----------------------	-------------------

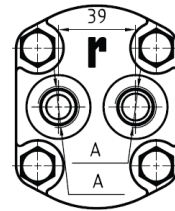

A	CODICE CODE
1/2" G	51
3/4" G	52
1 1/16 -12 UN	53

DIMENSIONI D'INGOMBRO
OVERALL DIMENSIONS

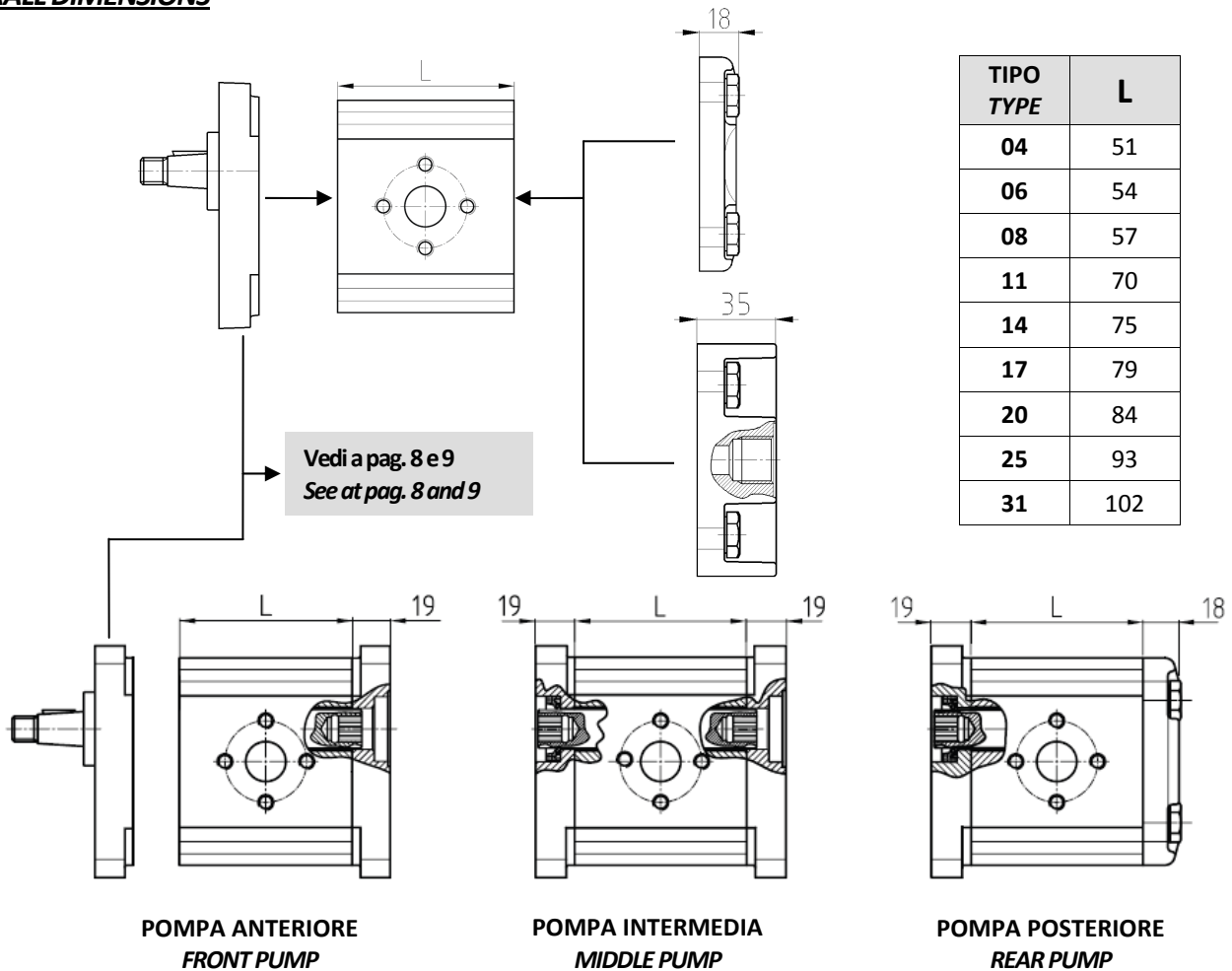

SUPPORTI CON CUSCINETTI A DOPPIA CORONA DI SFERE VERSIONE 1
OUTBOARD BEARING TYPE 1

DISPONIBILE PER FLANGE
 AVAILABLE FOR FLANGE

A0 -B1 -C4

DISPONIBILE PER ALBERI
 AVAILABLE FOR SHAFT

A -G -I -R -T



DIAGRAMMA CARICHI RADIALI ED ASSIALI AMMISSIBILI
 GRAPHIC OF RADIAL AND AXIAL LOAD



Coppia massima di trascinamento 100 Nm
Max torque 100 Nm

DATI DI BASE PER STESURA GRAFICO

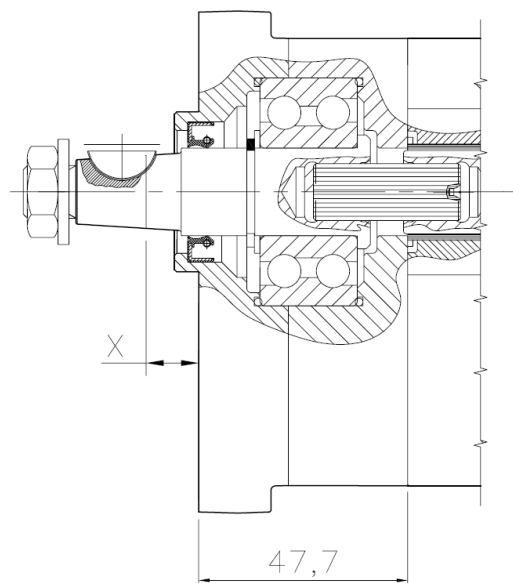
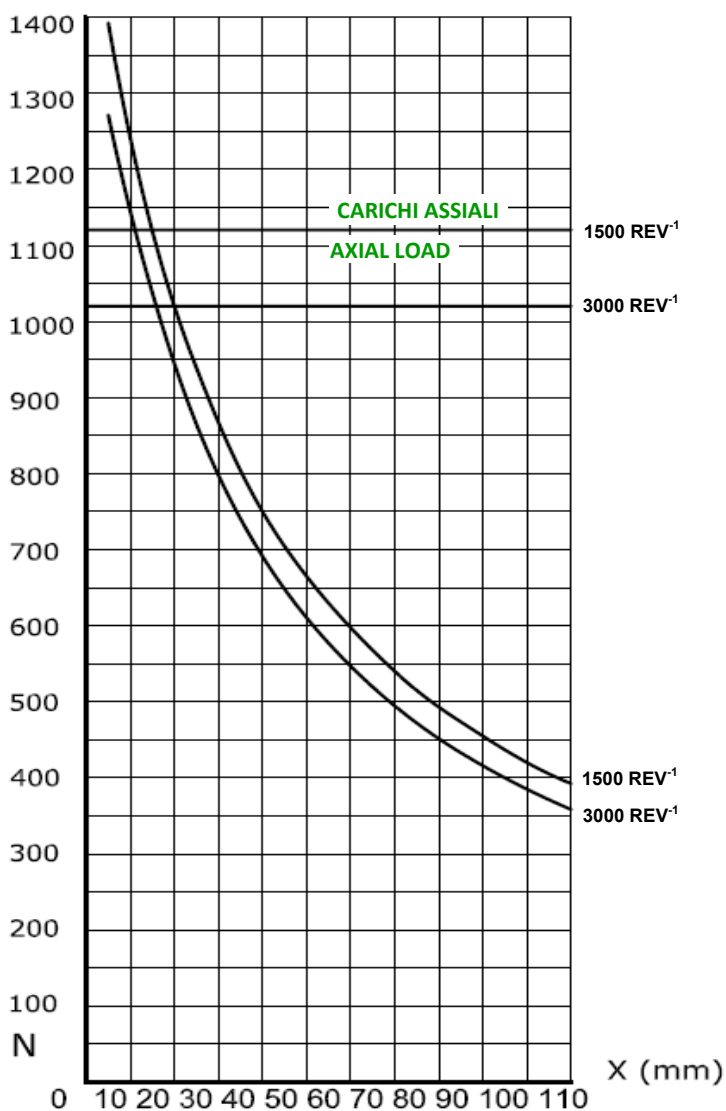
- Durata a fatica corretta 1000 h
- Olio VG-46
- Temperatura 60°C
- Affidabilità 90%
- Grado di contaminazione medio 10μ

IL VALORE DEI CARICHI E' INFLUENZATO DALLE CONDIZIONI DI FUNZIONAMENTO

LOAD GRAPH

- Rating fatigue life 1000 h
- Oil type VG-46
- Temperature 60°C
- Trust 90%
- Contamination 10 μ

LOAD VALUE IS AFFECTED BY WORKING CONDITIONS

SUPPORTI CON CUSCINETTI A DOPPIA CORONA DI SFERE VERSIONE 2
OUTBOARD BEARING TYPE 2

DISPONIBILE ANCHE COME "KIT" PER POMPE CON ALBERO TIPO "B"

AVAILABLE ALSO AS A "KIT" FOR PUMPS WITH SHAFT TYPE "B"

CARICO ASSIALE +2600N -2600N
AXIAL LOAD +2600N -2600N

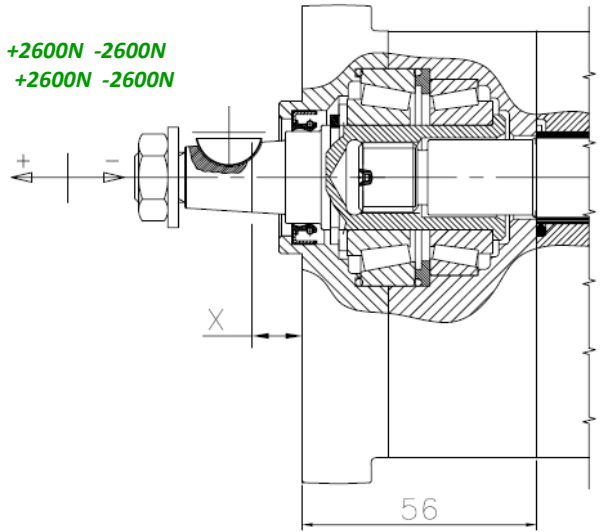

Coppia massima di trascinamento 110 Nm
Max torque 110 Nm

DIAGRAMMA CARICHI RADIALI AMMISSIBILI
GRAPHIC OF RADIAL LOAD

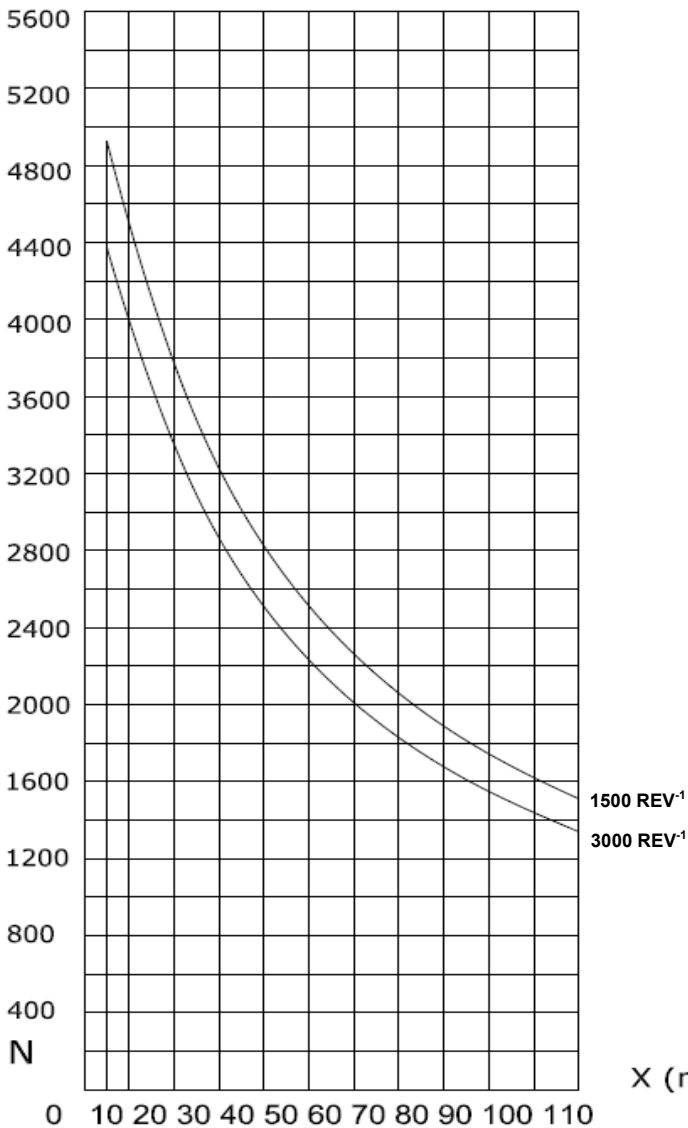

DATI DI BASE PER STESURA GRAFICO

- Durata a fatica corretta 1000 h
- Olio VG-46
- Temperatura 60°C
- Affidabilità 90%
- Grado di contaminazione medio 10μ

IL VALORE DEI CARICHI E' INFLUENZATO DALLE CONDIZIONI DI FUNZIONAMENTO

LOAD GRAPH

- Rating fatigue life 1000 h
- Oil type VG-46
- Temperature 60°C
- Trust 90%
- Contamination 10 μ

LOAD VALUE IS AFFECTED BY WORKING CONDITIONS

SUPPORTI CON CUSCINETTI A DOPPIA CORONA DI SFERE VERSIONE 3
OUTBOARD BEARING TYPE 3

CARICO ASSIALE +2600N -2600N
AXIAL LOAD +2600N -2600N

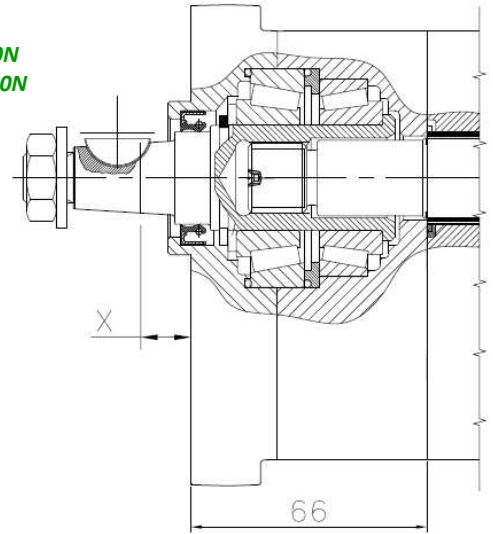

DISPONIBILE PER FLANGE
 AVAILABLE FOR FLANGE

A0 -B1 -C4 -N5

DISPONIBILE PER ALBERI
 AVAILABLE FOR SHAFT

A -G -Q -T

DIAGRAMMA CARICHI RADIALI AMMISSIBILI
GRAPHIC OF RADIAL LOAD

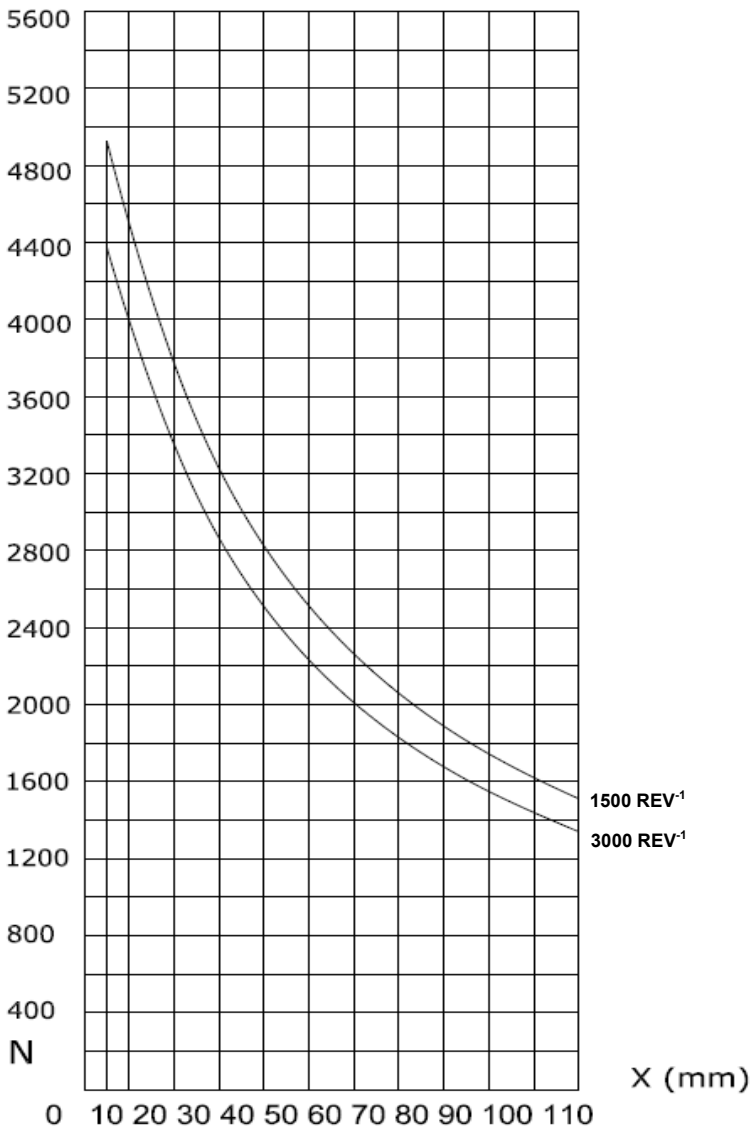

Coppia massima di trascinamento 175 Nm
Max torque 175 Nm

DATI DI BASE PER STESURA GRAFICO

- Durata a fatica corretta 1000 h
- Olio VG-46
- Temperatura 60°C
- Affidabilità 90%
- Grado di contaminazione medio 10μ

IL VALORE DEI CARICHI E' INFLUENZATO DALLE CONDIZIONI DI FUNZIONAMENTO

LOAD GRAPH

- Rating fatigue life 1000 h
- Oil type VG-46
- Temperature 60°C
- Trust 90%
- Contamination 10 μ

LOAD VALUE IS AFFECTED BY WORKING CONDITIONS

VALVOLA DI MASSIMA PRESSIONE RELIEF VALVE

VALVOLA A TARATURA REGOLABILE "VR" VALVE WITH ADJUSTABLE CALIBRATION "VR"

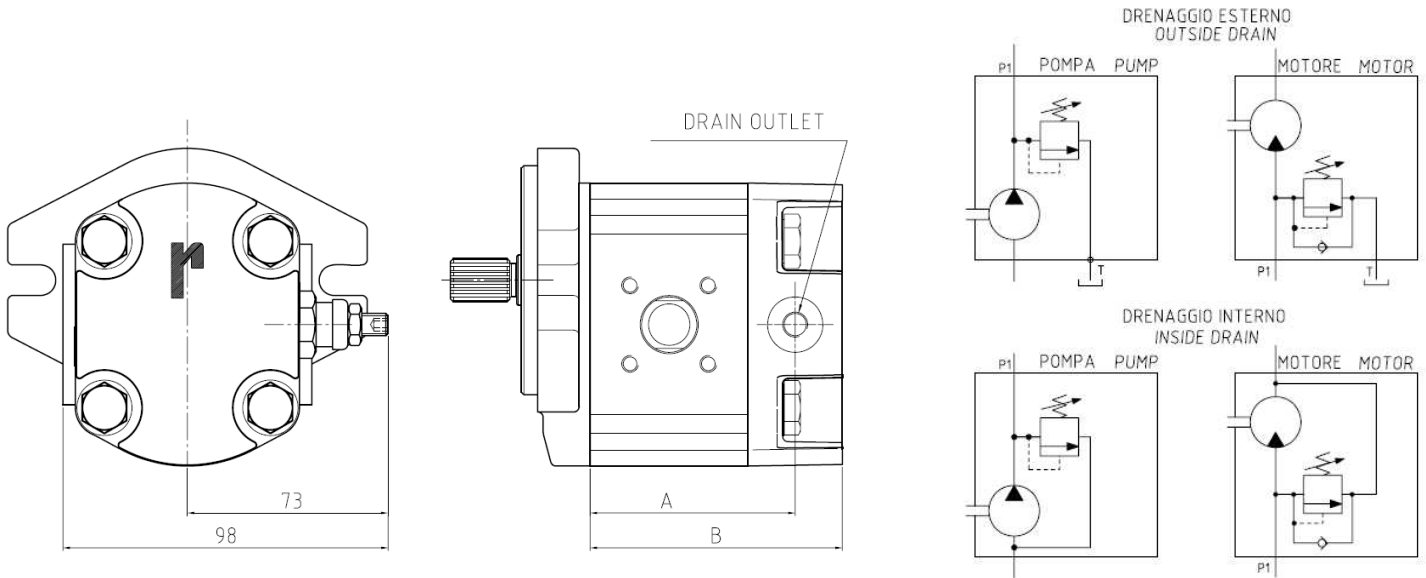

TYPE	04	06	08	11	14	17	20	25	31
A	86	89	92	105	110	114	119	128	137
B	66.5	69.5	72.5	85.5	90.5	94.5	99.5	108.5	117.5

VALVOLA A TARATURA FISSA "VF" VALVE WITH FIXED CALIBRATION "VF"

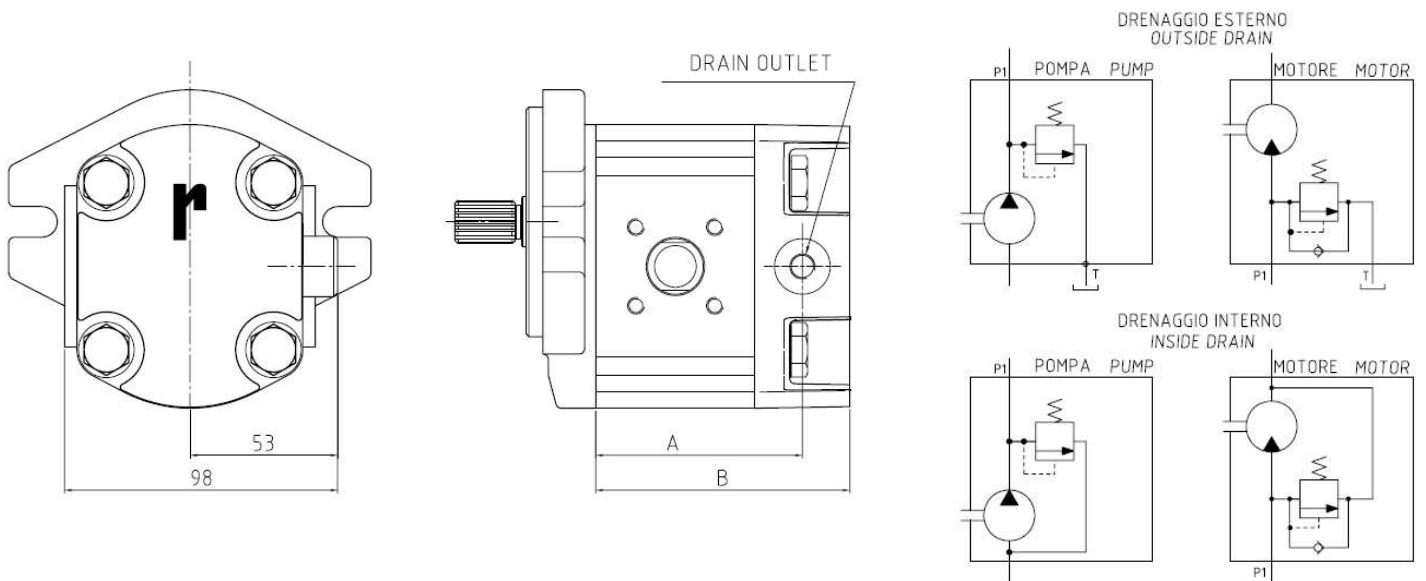

ISTRUZIONI PER L'ORDINAZIONE DI UNITA' SINGOLE Z2

HOW TO ORDER Z2 SINGLE UNITS

	1	2	3	4	5	6	7	8	9	10	11	12		
0	2	Z	A	G	06	E	0	34	S	-	0	B	VR	210

1	TIPO UNITA' / UNIT TYPE	CODICE / CODE
	PUMP	Z
	MOTOR	ZM

2-5	FLANGIA / FLANGE (PAG. 9-10)	CODICE / CODE
	EUROPA / EUROPEAN	A - 0
	TEDESCA / GERMAN	B - 1
	AMERICANA / AMERICAN	C - 4 / C - 7
	TEDESCA / GERMAN	D - 3 / D - 2
	TEDESCA / GERMAN	M - 3 / M - 2
	TEDESCA / GERMAN	E - 2
	AMERICANA / AMERICAN	F - 5
	TEDESCA / GERMAN	G - 3
	TEDESCA / GERMAN	L - 3
	EUROPEA CON DRENAGGIO / EUROPEAN WITH DRAIN	N - 4
	AMERICANA / AMERICAN	H - 6

3	CILINDRATA / CAPACITY cm ³	CODICE / CODE
	4.4	04
	6.3	06
	8.15	08
	11.3	11
	14.5	14
	16.9	17
	20.1	20
	25.7	25
	31.4	31

4	ALBERO / SHAFT (PAG. 11-12)	CODICE / CODE
	CONICO 1:5 / TAPERED 1:5	A
	17 x 14 DIN 5482	B
	CONICO 1:8 / TAPERED 1:8	C
	CILINDRICO Ø 15 / STRAIGHT Ø 15	E
	CILINDRICO Ø 13 / STRAIGHT Ø 13	H
	PENNA / TONGUE Ø18 x 8	F
	CILINDRICO Ø18 / STRAIGHT Ø18	G
	CILINDRICO Ø 15.85 / STRAIGHT Ø 15.85	L
	PENNA / TONGUE Ø18 x 8	M
	CILINDRICO Ø 20 / STRAIGHT Ø 20	I
	CILINDRICO Ø 19 / STRAIGHT Ø 19	N
	ANSI 921 11TH 16/32 FLAT ROOT	P
	CILINDRICO Ø 22 / STRAIGHT Ø 22	Q
	CILINDRICO Ø 19x45 / STRAIGHT Ø 19x45	R
	ANSI 921 9 TH 16/32 FLAT ROOT	S

	ANSI 921 13 TH 16/32 FLAT ROOT	T
	ANSI 921 9 TH 16/32 FLAT ROOT	U
	ANSI 921 11 TH 16/32 FLAT ROOT	K
	CILINDRICO Ø 22.22 / STRAIGHT Ø 22.22	V

6	BOCCHIE / PORTS (PAG.13)	CODICE / CODE
	EUROPEE / EUROPEAN	32 - 33 - 43
	TEDESCHE / GERMAN	36 - 44
	BSPP	34 - 35 - 41
	O-RING BOSS	37 - 38 - 39
	PORTE ANTERIORI-POSTERIORI / FRONT-REAR PORTS	49 - 50 - 51

7	ROTAZIONE / ROTATION	CODICE / CODE
	DESTRO / RIGHT	D
	SINISTRO / LEFT	S
	BIDIRECTIONAL WITH INTERNAL DRAIN	Y
	BIDIRECTIONAL WITH EXTERNAL DRAIN	R

8	TIPO UNITA' / UNIT TYPE	CODICE / CODE
	PREDISPOSTA TANDEM / FOR TANDEM	T
	NIENTE / NONE	-

9	SUPPORTI / SUPPORT (PAG.15-16)	CODICE / CODE
	SENZA / WITHOUT	0
	CUSCINETTO A DOPPIA CORONA DI SFERE	1
	DOPPIO CUSCINETTO A RULLI CONICI	2
	DOPPIO CUSCINETTO A RULLI CONICI	3

10	PARAOILIO / SHAFT SEAL (PAG.7)	CODICE / CODE
	STANDARD / STANDARD	N
	STANDARD VITON / STANDARD VITON	V
	5 BAR NBR / 5 BAR NBR	R
	5 BAR VITON / 5 BAR VITON	RV
	DOPPIO MIM NBR / DOUBLE SEAL NBR	N2
	DOPPIO MIM VITON / DOUBLE SEAL VITON	V2
	25 BAR VARISEAL NBR / 25 BAR VARISEAL NBR	B
	25 BAR NBR / 25 BAR NBR	BN
	25 BAR VITON / 25 BAR VITON	BV

11	VALVOLA DI MASSIMA / RELIEF VALVE	CODICE / CODE
	SENZA / WITHOUT	-
	TARATURA REGOLABILE / ADJUST. CALIBRATION	VR
	TARATURA FISSA / FIXED CALIBRATION	VF

12	VALORI TARATURA VALVOLA	CODICE / CODE
	50 - 75 - 100 - 125 - 150 - 200 - 250 - 300 - 330	

KIT DI MONTAGGIO POMPE MULTIPLE Z2 CON STADI A FLUSSI SEPARATI
ASSEMBLING KITS FOR MULTIPLE PUMPS Z2 WITH SEPARATED FLOW

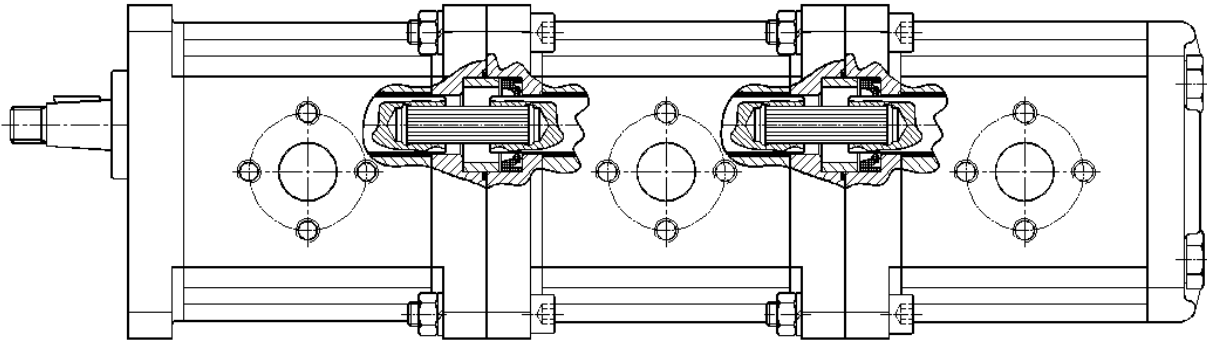

$\text{Cm}^3 / \text{giro}$ Cm^3 / rev	+	$\text{Cm}^3 / \text{giro}$ Cm^3 / rev	Codice Kit Code Kit
31-25-20-17-14-11		31-25-20-17-14-11	K2000000
8-6-4		8-6-4	K2000002

La pressione delle pompe intermedie e posteriori è limitata dalla tenuta dell'albero Z=25. La coppia max è **100 Nm**

Max. shaft loading must conform to the limitations of shaft Z=25. Max torque is **100 Nm**

Ref	PARTI PARTS
1	M8 x 40 UNI 5931
2	OR 2125
3	Bussola di centraggio Pilot ring
4	Rosetta Washer
5	Dado M8 Stud nut M8
6	Albero Z=25 Splined shaft Z=25

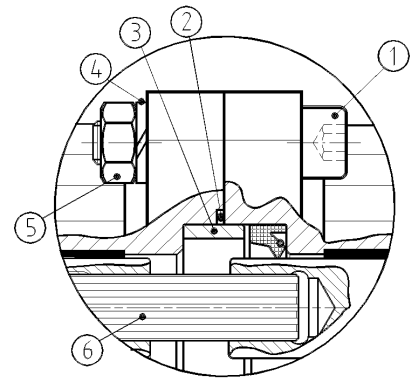

KIT DI MONTAGGIO POMPE MULTIPLE Z2-Z1
ASSEMBLING KITS FOR MULTIPLE PUMPS Z2-Z1

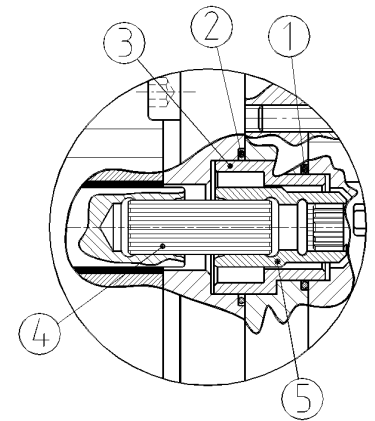
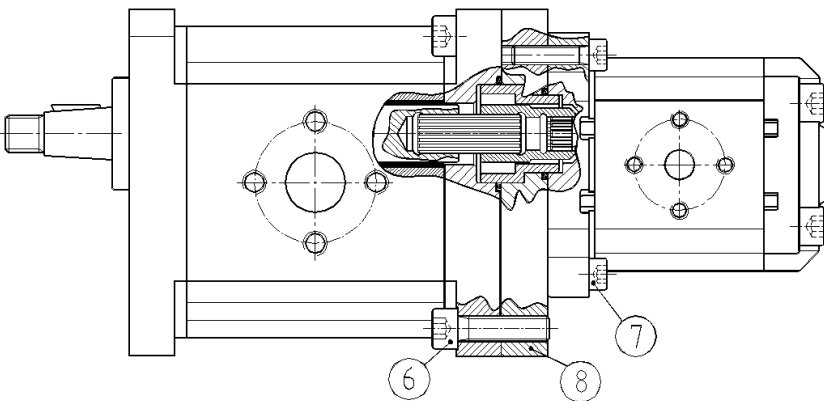

Pompa Z2+Z1 tutti i tipi Pump Z2+Z1 all of type	Codice Kit Code Kit
Tipo Type 31-25-20-17-14-11	K2000003
Tipo Type 8-6-4	K2000004

Ref	PARTI / PARTS
1	OR 2100
2	OR 2125
3	Bussola di centraggio / Pilot ring
4	Albero Z=25 / Splined shaft Z=25
5	Mozzo Z25-12x9 / Coupling Z25-12x9
6	M8 x 30 UNI 5931
7	M6 x 25 UNI 5931
8	Piastra collegamento / Connection plate

ISTRUZIONI PER L'ORDINAZIONE DI UNITA' MULTIPLE Z2

HOW TO ORDER Z2 MULTIPLE UNITS

			1		2	3	4	5		6	7	8	
0	2	Z	A	G	06	E	0	34	A	S	B	0	POMPA ANTERIORE FRONT PUMP
	*				2*			5*		6	7		
0	2	Z	A	G	06	0	0	34	I	S	B		POMPA INTERMEDIA Z2 o Z1 MIDDLE PUMP Z2 or Z1
	*				2*			5*		6	7		
0	2	Z	A	G	06	0	0	34	P	S	B		POMPA POSTERIORE Z2 o Z1 REAR PUMP Z2 or Z1

* per tandem con pompe Z1 consultare il relativo catalogo
* for tandem with Z1 pumps please check relative catalogue

1 - 4	FLANGIA / FLANGE (PAG. 9-10)	CODICE / CODE
	EUROPA / EUROPEAN	A - 0
	TEDESCA / GERMAN	B - 1
	AMERICANA / AMERICAN	C - 4
	TEDESCA / GERMAN	D - 3
	TEDESCA / GERMAN	M - 3
	TEDESCA / GERMAN	E - 2
	AMERICANA / AMERICAN	F - 5
	TEDESCA / GERMAN	G - 3
	TEDESCA / GERMAN	L - 3
	EUROPEA CON DRENAGGIO / EUROPEAN WITH DRAIN	N - 4

2	CILINDRATA / CAPACITY cm ³	CODICE / CODE
	4.4	04
	6.3	06
	8.15	08
	11.3	11
	14.5	14
	16.9	17
	20.1	20
	25.7	25
	31.4	31

5	BOCCHIE / PORTS (PAG.13)	CODICE / CODE
	EUROPEE / EUROPEAN	32 - 33 - 43
	TEDESCHE / GERMAN	36 - 44
	BSPP	34 - 35 - 41
	O-RING BOSS	37 - 38 - 39

3	ALBERO / SHAFT (PAG. 11-12)	CODICE / CODE
	CONICO 1:5 / TAPERED 1:5	A
	17 x 14 DIN 5482	B
	CONICO 1:8 / TAPERED 1:8	C
	CILINDRICO Ø 15 / STRAIGHT Ø 15	E
	CILINDRICO Ø 13 / STRAIGHT Ø 13	H

PENNA / TONGUE Ø18 x 8	F
CILINDRICO Ø18 / STRAIGHT Ø18	G
CILINDRICO Ø 15.85 / STRAIGHT Ø 15.85	L
PENNA / TONGUE Ø18 x 8	M
CILINDRICO Ø 20 / STRAIGHT Ø 20	I
CILINDRICO Ø 19 / STRAIGHT Ø 19	N
ANSI 921 11TH 16/32 FLAT ROOT	P
CILINDRICO Ø 22 / STRAIGHT Ø 22	Q
CILINDRICO Ø 19x45 / STRAIGHT Ø 19x45	R
ANSI 921 9 TH 16/32 FLAT ROOT	S
ANSI 921 13 TH 16/32 FLAT ROOT	T
ANSI 921 9 TH 16/32 FLAT ROOT	U
ANSI 921 11 TH 16/32 FLAT ROOT	K
CILINDRICO Ø 22.22 / STRAIGHT Ø 22.22	V

6	ROTAZIONE / ROTATION	CODICE / CODE
	DESTRO / RIGHT	D
	SINISTRO / LEFT	S

7	PARAOILIO / SHAFT SEAL (PAG.7)	CODICE / CODE
	STANDARD / STANDARD	N
	STANDARD VITON / STANDARD VITON	V
	5 BAR NBR / 5 BAR NBR	R
	5 BAR VITON / 5 BAR VITON	RV
	DOPPIO MIM NBR / DOUBLE SEAL NBR	N2
	DOPPIO MIM VITON / DOUBLE SEAL VITON	V2
	25 BAR VARISEAL NBR / 25 BAR VARISEAL NBR	B
	25 BAR NBR / 25 BAR NBR	BN
	25 BAR VITON / 25 BAR VITON	BV

8	SUPPORTI / SUPPORT (PAG.15-16)	CODICE / CODE
	SENZA / WITHOUT	0
	CUSCINETTO A DOPPIA CORONA DI SFERE	1
	DOPPIO CUSCINETTO A RULLI CONICI	2
	DOPPIO CUSCINETTO A RULLI CONICI	3

KIT DI MONTAGGIO POMPE MULTIPLE COMPATTE Z2 CON ENTRATA COMUNE O SEPARATA
ASSEMBLING KITS FOR MULTIPLE COMPACT PUMPS Z2 WITH COMMON OR SEPARATED INLET PORTS

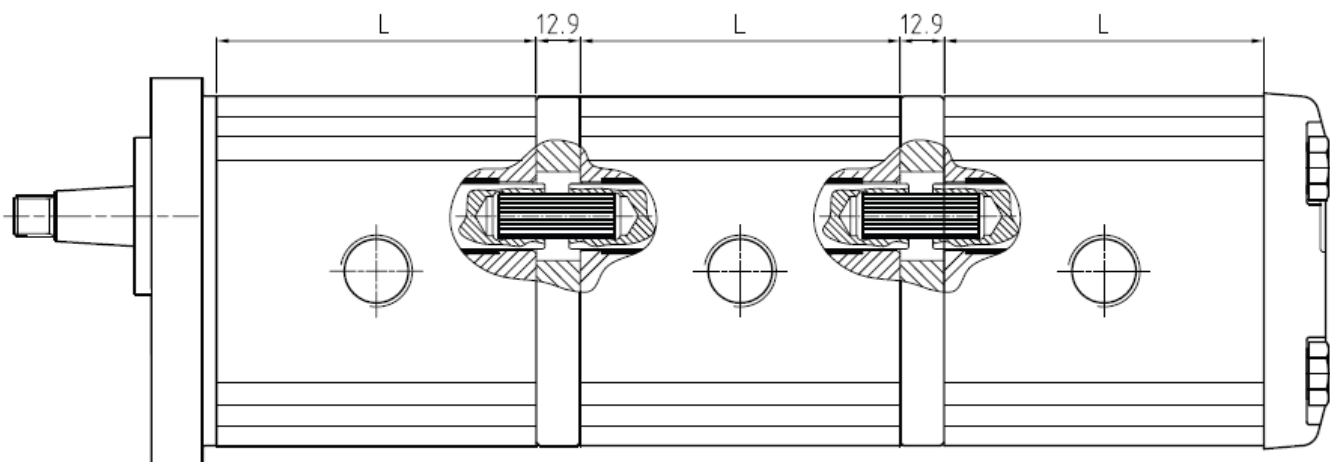

$\text{Cm}^3 / \text{giro}$ Cm^3 / rev	+	$\text{Cm}^3 / \text{giro}$ Cm^3 / rev	Codice Kit Code Kit
31-25-20-17-14-11		31-25-20-17-14-11	K2000006
31-25-20-17-14-11		8-6-4	K2000006
8-6-4		8-6-4	K2000008

La pressione delle pompe intermedie e posteriori è limitata dalla tenuta dell'albero Z=25. La coppia max è **100 Nm**

Max. shaft loading must conform to the limitations of shaft Z=25. Max torque is **100 Nm**

Ref	PARTI PARTS
1	Albero Z=25 Splined shaft Z=25
2	Flangia 95-194 Flange 95-194
3	OR2.6/61.6

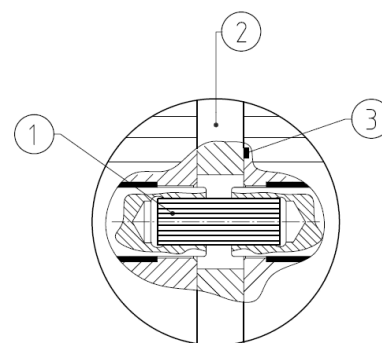

BOCCHIE ADDIZIONALI PER POMPE MULTIPLE Z2 CON ENTARATA COMUNE O SEPARATA ADDITIONAL PORTS FOR MULTIPLE COMPACT PUMPS Z2								
PORTE GAS GAS PORTS			PORTE UNF UNF PORTS			PORTE FLANGIATE FLANGED PORTS		
ENTRATA INLET	USCITA OUTLET	CODICE CODE	ENTRATA INLET	USCITA OUTLET	CODICE CODE	ENTRATA INLET	USCITA OUTLET	CODICE CODE
//	1/2 G	01	//	7/8	11	//	13-30/M6	21
//	3/4 G	02	//	1" 1/16	12	//	15-35/M6	22
1" G	1/2 G	03	1" 5/16	7/8	13	27-55/M8	15-35/M6	23
1" G	3/4 G	04	1" 5/16	1" 1/16	14			
1" 1/4 G	3/4 G	05	1" 5/8	1" 1/16	15			
1" 1/2 G	3/4 G	06						

ISTRUZIONI PER L'ORDINAZIONE POMPE MULTIPLE COMPATTE Z2

HOW TO ORDER MULTIPLE COMPACT PUMPS Z2

	1	2	3	4	5	6	7	8	9	10	11	12			
0	2	Z	A	G	06*	06*	06*	E	0	34*	34*	34*	S	R	0

ESEMPIO PER POMPA A TRE STADI
EXAMPLE FOR A PUMP WITH THREE STAGES

1 - 6	FLANGIA / FLANGE (PAG. 9-10)	CODICE / CODE
	EUROPA / EUROPEAN	A - 0
	TEDESCA / GERMAN	B - 1
	AMERICANA / AMERICAN	C - 4
	TEDESCA / GERMAN	D - 3
	TEDESCA / GERMAN	M - 3
	TEDESCA / GERMAN	E - 2
	AMERICANA / AMERICAN	F - 5
	TEDESCA / GERMAN	G - 3
	TEDESCA / GERMAN	L - 3
	EUROPEA CON DRENAGGIO / EUROPEAN WITH DRAIN	N - 4

2-3-4	CILINDRATA / CAPACITY cm ³	CODICE / CODE
	4.4	04
	6.3	06
	8.15	08
	11.3	11
	14.5	14
	16.9	17
	20.1	20
	25.7	25
	31.4	31

7-8-9	BOCCHIE / PORTS (PAG.13 -18-22)	CODICE / CODE
	EUROPEE / EUROPEAN	32 - 33 - 43 - 21
	TEDESCHE / GERMAN	36 - 44
	GAS	01 - 02 - 03 - 04 - 05 - 06 - 34 - 35 - 40
	SAE	11 - 12 - 13 - 14 - 15 - 37 - 38 - 39

5	ALBERO / SHAFT (PAG. 11-12)	CODICE / CODE
	CONICO 1:5 / TAPERED 1:5	A
	17 x 14 DIN 5482	B
	CONICO 1:8 / TAPERED 1:8	C
	CILINDRICO Ø 15 / STRAIGHT Ø 15	E
	CILINDRICO Ø 13 / STRAIGHT Ø 13	H
	PENNA / TONGUE Ø18 x 8	F
	CILINDRICO Ø18 / STRAIGHT Ø18	G

	CILINDRICO Ø 15.85 / STRAIGHT Ø 15.85	L
	PENNA / TONGUE Ø18 x 8	M
	CILINDRICO Ø 20 / STRAIGHT Ø 20	I
	CILINDRICO Ø 19 / STRAIGHT Ø 19	N
	ANSI 921 11TH 16/32 FLAT ROOT	P
	CILINDRICO Ø 22 / STRAIGHT Ø 22	Q
	CILINDRICO Ø 19x45 / STRAIGHT Ø 19x45	R
	ANSI 921 9 TH 16/32 FLAT ROOT	S
	ANSI 921 13 TH 16/32 FLAT ROOT	T
	ANSI 921 9 TH 16/32 FLAT ROOT	U
	ANSI 921 11 TH 16/32 FLAT ROOT	K
	CILINDRICO Ø 22.22 / STRAIGHT Ø 22.22	V

10	ROTAZIONE / ROTATION	CODICE / CODE
	DESTRO / RIGHT	D
	SINISTRO / LEFT	S

11	PARAOILIO / SHAFT SEAL (PAG.7)	CODICE / CODE
	STANDARD / STANDARD	N
	STANDARD VITON / STANDARD VITON	V
	5 BAR NBR / 5 BAR NBR	R
	5 BAR VITON / 5 BAR VITON	RV
	DOPPIO MIM NBR / DOUBLE SEAL NBR	N2
	DOPPIO MIM VITON / DOUBLE SEAL VITON	V2
	25 BAR VARISEAL NBR / 25 BAR VARISEAL NBR	B
	25 BAR NBR / 25 BAR NBR	BN
	25 BAR VITON / 25 BAR VITON	BV

12	SUPPORTI / SUPPORT (PAG.15-16)	CODICE / CODE
	SENZA / WITHOUT	0
	CUSCINETTO A DOPPIA CORONA DI SFERE	1
	DOPPIO CUSCINETTO A RULLI CONICI	2
	DOPPIO CUSCINETTO A RULLI CONICI	3

* INSERIRE NEL CODICE IL VALORE PER OGNI POMPA DESIDERATA
INSERT IN THE CODE THE VALUE FOR EACH PUMPS EXPECTED

POMPA MULTIPLA Z2 CON VALVOLA DISGIUNTRICE
MULTIPLE PUMP Z2 WITH SEQUENCE VALVE (HIGH-LOW PUMP)

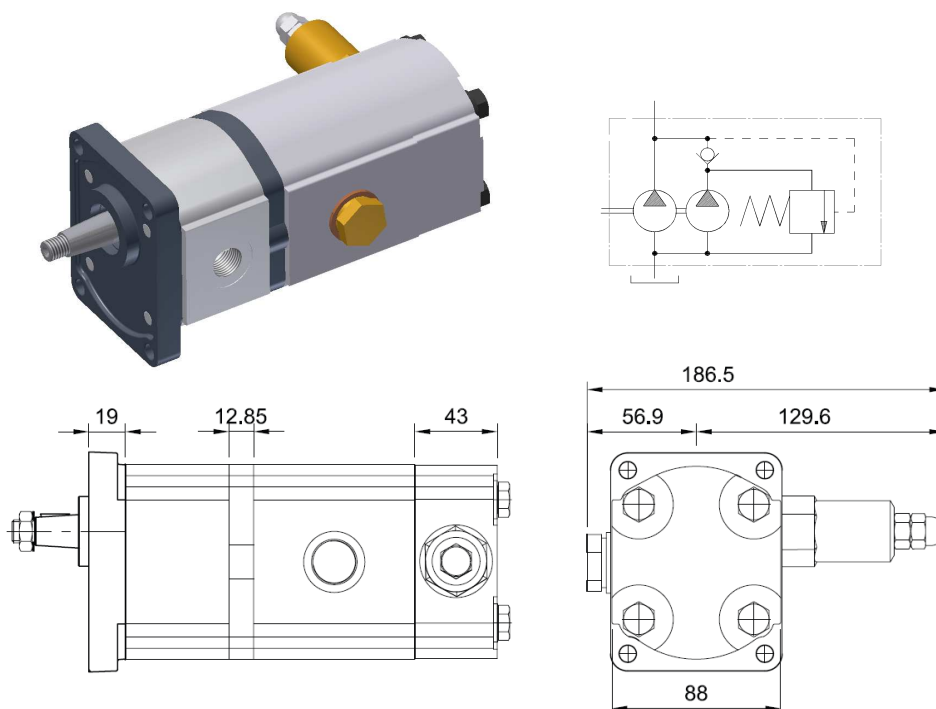

			1	2				3	4	5	6	7	8
0	2	Z	A	0	G	D		20	6	E	43	D	R

1 - 2	FLANGIA / FLANGE (PAG. 9-10)	CODICE / CODE
	EUROPA / EUROPEAN	A - 0
	TEDESCA / GERMAN	B - 1
	AMERICANA / AMERICAN	C - 4
	TEDESCA / GERMAN	D - 3
	TEDESCA / GERMAN	M - 3
	TEDESCA / GERMAN	E - 2
	AMERICANA / AMERICAN	F - 5
	TEDESCA / GERMAN	G - 3
	TEDESCA / GERMAN	L - 3

5	ALBERO / SHAFT (PAG. 11-12)	CODICE / CODE
	VEDI PAG (11-12) / SEE PAGE (11-12)	

6	BOCCHIE / PORTS (PAG.13)	CODICE / CODE
	GAS	34 - 35 - 40
	SAE	37 - 38 - 39

7	ROTAZIONE / ROTATION	CODICE / CODE
	DESTRO / RIGHT	D
	SINISTRO / LEFT	S

3 - 4	CILINDRATA / CAPACITY cm ³	CODICE / CODE
	3 - PRIMO STADIO / FIRST STAGE 4 - SECONDO STADIO / SECOND STAGE	
	4.4	04
	6.3	06
	8.15	08
	11.3	11
	14.5	14
	16.9	17
	20.1	20
	25.7	25
	31.4	31

8	PARAOILIO / SHAFT SEAL (PAG.7)	CODICE / CODE
	STANDARD / STANDARD	N
	STANDARD VITON / STANDARD VITON	V
	5 BAR NBR / 5 BAR NBR	R
	5 BAR VITON / 5 BAR VITON	RV



RONZIO
OLEODINAMICA