

M45

MONOBLOCK VALVE



TECHNICAL CATALOGUE

A member of



1800-OILSOL
1800-645765

<https://oilsolutions.com.au/>

sales@oilsolutions.com.au

1st edition M45.01

*This catalogue shows the product in the most standard configurations.
Please contact our Sales Dpt. for more detailed information or special requests.*

WARNING!

*All specifications of this catalogue refer to the standard product at this date.
Walvoil, oriented to a continuous improvement, reserves the right to
discontinue, modify or revise the specifications, without notice.*

**WALVOIL IS NOT RESPONSIBLE FOR ANY DAMAGE CAUSED BY AN
INCORRECT USE OF THE PRODUCT.**



Applications

A big number of options and solutions make M45 a very flexible product; it can be easily adapted to many different applications always fitting the specific needs (mobile cranes, agricultural machines, mini skid loaders, mini dumpers, fork lift truck, etc...).

The valve is available with manual, cable, direct electric, hydraulic remote, pneumatic, electrohydraulic and electropneumatic controls. Floating is possible on standard body. Regenerative functions are possible with dedicated spools and bodies. Numerous configurations and solutions are possible.

Following options are available:

- special versions with left inlet
- direct electric control push-push type
- special circuits for stabilizers applications
- fork lift truck set up with potentiometer and microswitches





QUICK REFERENCE GUIDE

GENERAL SPECIFICATION	M45	M50	TR55
Working sections number	1 - 6	1 - 7	1 - 7
CIRCUIT			
Parallel	•	•	•
Tandem		•	
Parallel circuit stroke (mm)	5	5,5	5
Float spool extra stroke (mm)	4	4,5	4,5
Spools pitch (mm)	35	35	36
RATED FLOW			
Max recommended flow rate (l/min)	45	50	50
Max recommended flow rate (GPM)	12	15	15
RATED PRESSURE			
Max working pressure (bar)	350	350	350
Max working pressure (PSI)	5000	5000	5000

OPTION CHART	M45	M50	TR55
Direct acting pressure relief valve	•	•	•
Clamping valve			(•)
Externally piloted valve	(•)	(•)	
Solenoid dump valve (12 Vdc)	(•)	(•)	
Solenoid dump valve (24 Vdc)	(•)	(•)	
SPOOL ACTUATION			
Manual control	•	•	•
Without lever	•	•	•
90° joystick control	•	•	•
Hydraulic control		•	•
Direct electric control (12-24 Vdc)		•	
SPOOL RETURN ACTION			
Return spring	•	•	•
Detent in A - in B - in A/B	•	•	•
Detent in 4 th position	•	•	•
Arrangement for dual control	•	•	•
Hydraulic load limit	•	•	•
Pneumatic control ON - OFF	•	•	•
Proportional pneumatic control	•	•	•
Electrical load limit	•	•	•
Electrohydraulic control ON-OFF (12-24 Vdc)	•	•	•
Electrohydraulic control PROP. (12-24 Vdc)	•	•	•
Electropneumatic control (12-24 Vdc)	•	•	•
AUXILIARY VALVES			
Valves on port		•	•

(•) = the application requires special machining in the body



GENERAL INDEX

4	<p>General specifications Standard working conditions Fluid options</p>
5	<p>Order example Standard thread Painting Hydraulic circuit</p>
7	<p>Dimensions</p>
8	<p>Typical curves Pressure drop (P - T) Pressure drop (P - A/B) Pressure drop (A/B - T) Direct relief valve curve</p>
9	<p>Inlet arrangement Inlet side classification Valve identification Valve arrangement</p>
10	<p>Work section arrangement Spool identification Spool actuation classification Spool return action classification - Spring load values</p>
21	<p>Outlet arrangement Order example - version 1 outlet Order example - HPCO version outlet Outlet with single tank classification Outlet with two tanks classification Carry-over connection (HPCO)</p>
25	<p>M45 Spare parts list</p>
27	<p>Installation</p>
29	<p>General conditions and patents</p>

The specifications detailed in this catalogue show standard products. Special applications are available to order subject to contacting our Engineering Department for an estimate. The data and specifications indicated are to be considered a guide only and Hydrocontrol S.p.A. reserves the right to introduce improvements and modifications without prior notice. Hydrocontrol is not responsible for any damage caused by an incorrect use of the product.



GENERAL SPECIFICATIONS

Standard working conditions

Description	Value
Ambient operating temperature range	-40°C / +60°C
Kinematic viscosity range	10 ÷ 300 cSt
Max contamination level	9 (NAS 1638) - 20/18/15 (ISO 4406:1999)
Recommended filtration level	$\beta_{10} > 75$ (ISO 16889:2008)
Internal filter (on electroproportional valves pilot line)	30 μm

All information and diagrams in this catalogue refer to a mineral base oil VG46 at 50°C temperature (32 cSt kinematic viscosity)

Fluid options

Types of fluid (according to ISO 6743/4) Oil and Solutions	Temperature (°C)		Compatible gasket
	min	max	
Mineral Oil HL, HM (or HLP acc. to DIN 51524)	-25	+80	NBR
Oil in water emulsions HFA	+5	+55	NBR
Water in oil emulsions HFB	+5	+55	NBR
Polyglycol-based aqueous solution HFC	-10	+60	NBR

For special applications and different fluids, please call our Technical Department.



ORDER EXAMPLE

M45/1:	IR 301 150	W001A H001 F001A	MJ A G03
<p>TYPE: _____</p> <p>M45: product type /1: working section number</p> <p>1) INLET ARRANGEMENT: page 9 _____</p> <p>IR 301 inlet side and valve type 150 setting (bar)</p> <p>2) WORK SECTION ARRANGEMENT: page 10 _____</p> <p>2.1 W001A spool type 2.2 H001 spool actuation type 2.3 F001A spool return action type</p> <p>3) OUTLET ARRANGEMENT: page 21 _____</p> <p>MJ outlet type A G03 outlet position and available thread type</p>			

Ordering row 2 must be repeated for every work section

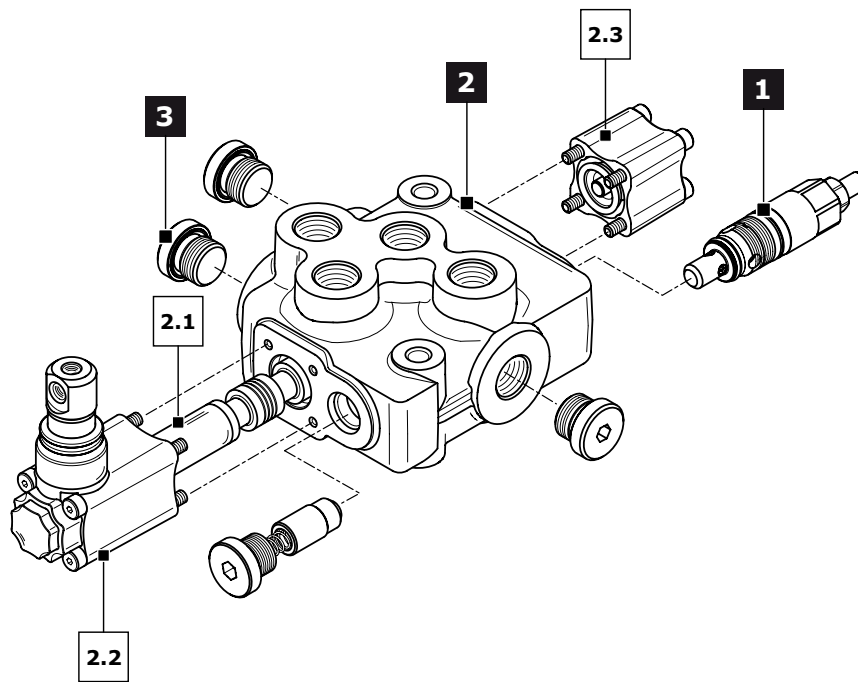

Standard thread

The connection ports size is indicated by an ordering code common for all Hydrocontrol products. Following table shows all available connections; for ordering code refer to table on page 28.

Ports	BSP (ISO - 228)	Code	UN-UNF (ISO - 725)	Code
Inlet Port (P)	G 3/8	G03	3/4" - 16 UNF	U03
Ports (A - B)	G 3/8	G03	3/4" - 16 UNF	U03
Outlet (T) - Carry over (HPCO)	G 3/8	G03	3/4" - 16 UNF	U03
Hydraulic Pilot	G 1/4	G02	9/16" - 18 UNF	U02
Pneumatic Pilot	G 1/8	-	NPTF 1/8-27	-



Painting

On request, all Hydrocontrol valves can be delivered painted (RAL 9005 black primer).

Order example of M45/1 painted:

M45/1
IR 301 150
W001A H001
MJ A G03
P006/1 N10

The painting is indicated with the following value:

P006 - /1 - N10

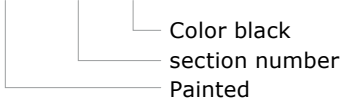

Hydraulic circuit

Parallel circuit

When the spool is operated it intercepts the switch gallery by diverting the flow of oil to service port A or B. If two or more spools are actuated at the same time, the oil will power the service port that has the lower load by selecting the path with the least resistance; by throttling the spools, the flow of oil can be divided between two or more service ports.

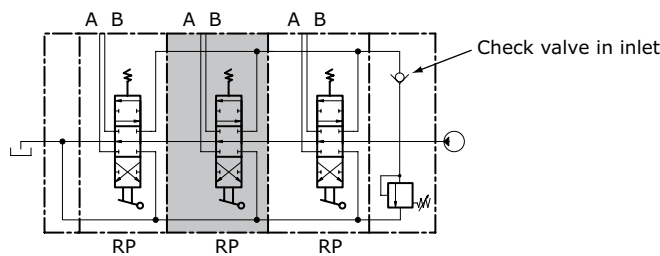



DIMENSIONS

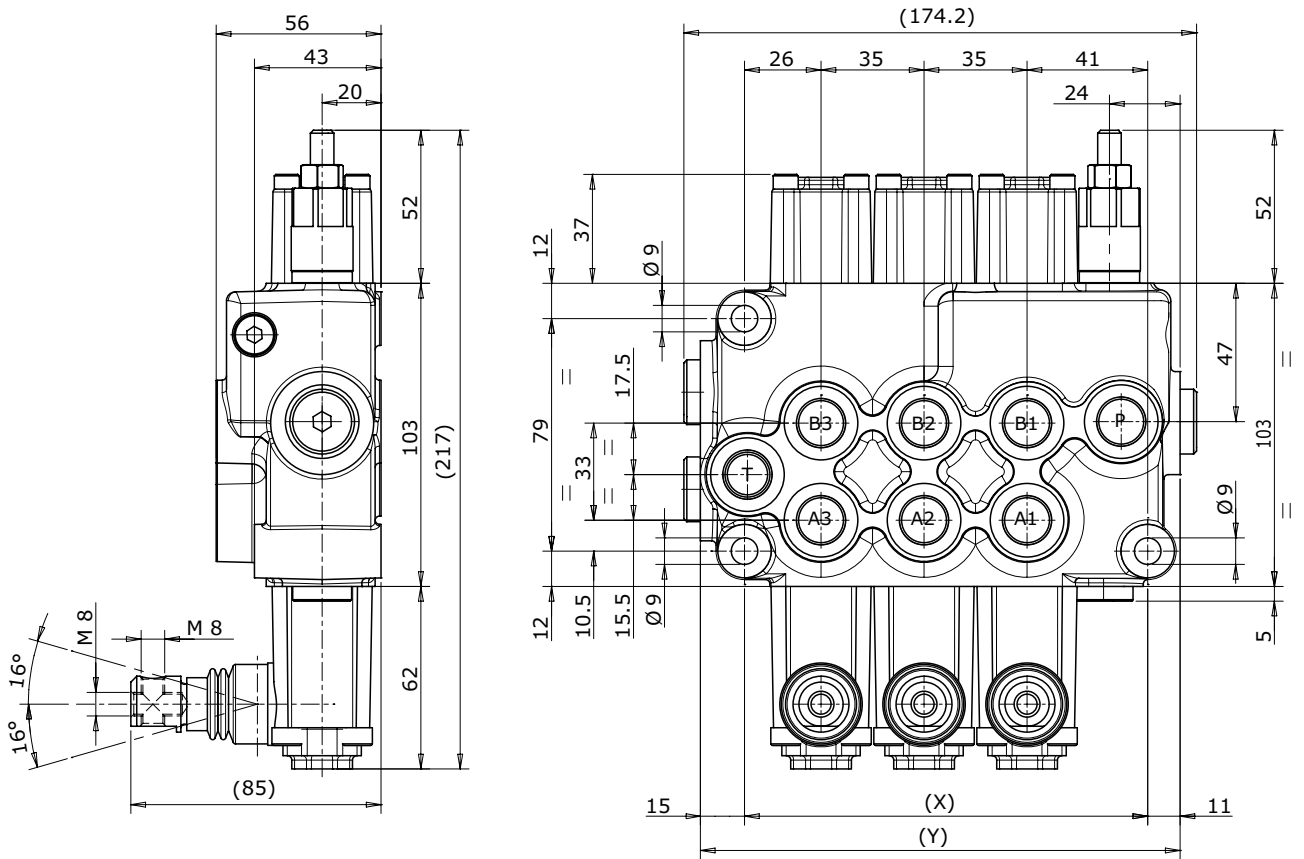

TYPE	M45/1	M45/2	M45/3	M45/4	M45/5	M45/6
X (mm)	67	102	137	172	207	242
Y (mm)	93	128	163	198	233	268
Weights (kg)	2,70	4,10	5,50	6,90	8,30	9,70



TYPICAL CURVES

Indicated values have been tested with standard sectional valve and W001A spool.

Pressure drop (P - T)

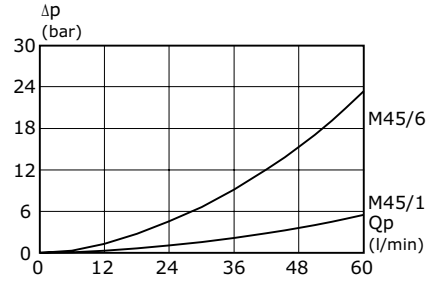
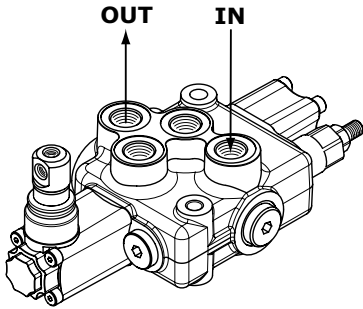

Pressure drop (P - A/B)

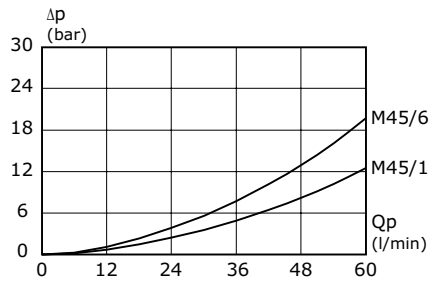
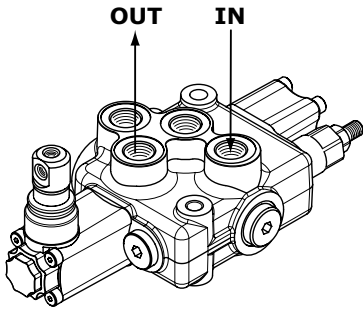

Pressure drop (A/B - T)

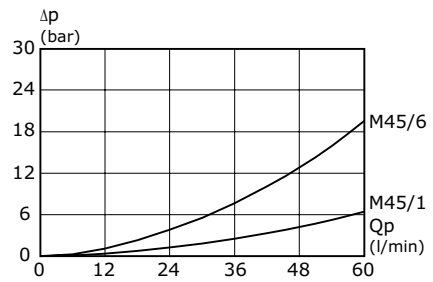
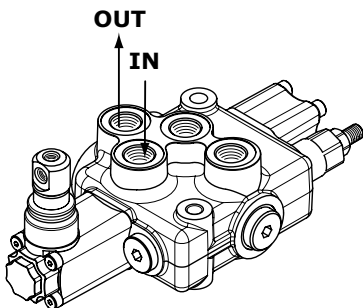

Direct relief valve curve

Setting ranges	
type	pressure (bar)
A	10 - 40
B	41 - 70
C	71 - 130
D	131 - 210
E	211 - 350

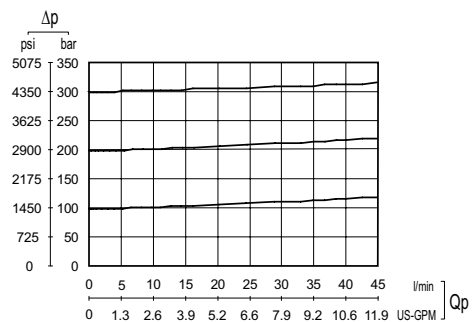



INLET ARRANGEMENT

Inlet side classification

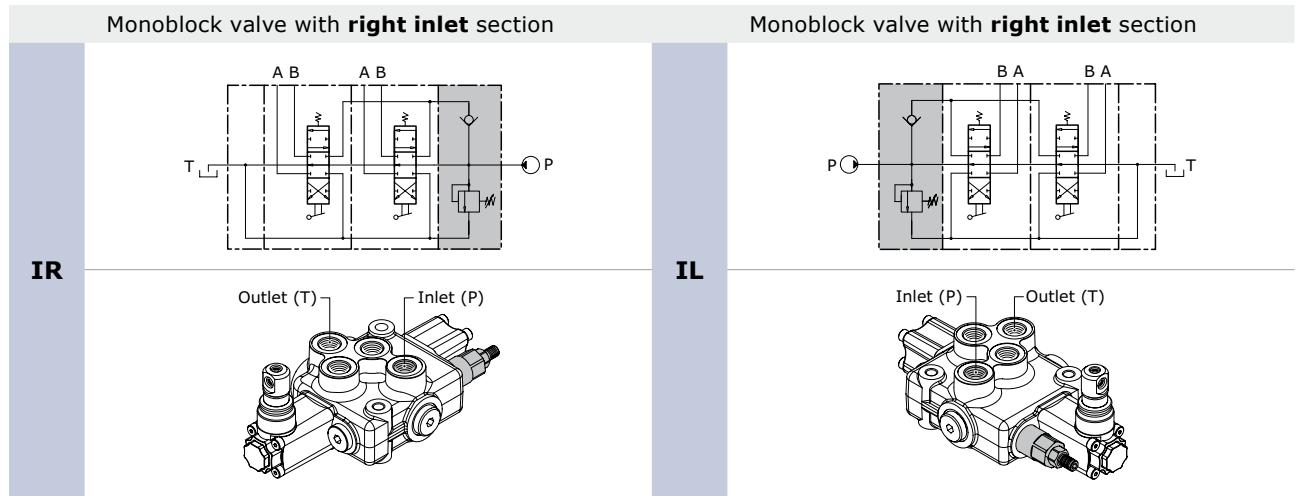

Valve identification

type	schema	layout	description	type	schema	layout	description
1			Direct acting pressure relief valve	3			Relief valve plugged

NOTE:

Monoblock valves can be equipped with externally piloted valve, solenoid dump valve (12-24 Vdc), clamping valve. These applications needs a special valve body. Ask our commercial dept. for further informations.

Valve arrangement

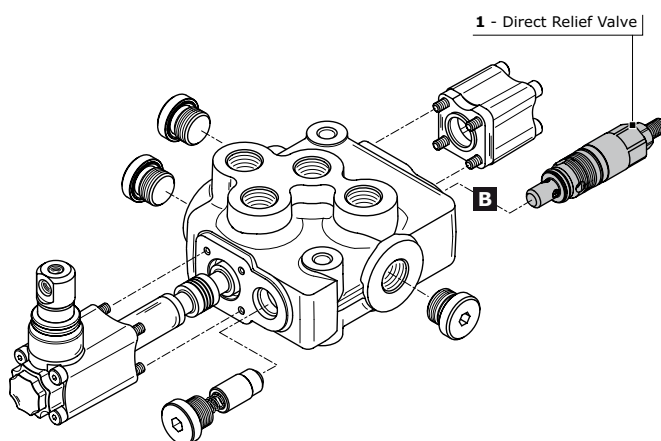

Combination valve example: 301 = 1B

- 301** Combination valve
- 1B** Pressure relief valve in port B

The code identifies:
with a number, the type of valve; with a letter its position on the inlet section.

(A) = spool action side (B) = spool return action side

NOTE:
when ordering a main relief valve it is necessary to specify setting (example 150 bar).

valves combination	M45 - IR	M45 - IL
1A	201	•
3A	203	•
1B	301	•
3B	303	•



WORK SECTION ARRANGEMENT

Spool identification

order example of spool: **W001 A J10**

W001 spool schema 3 positions double-acting
A spool type spool with 45 l/min inlet flow
J10 restricted service ports restriction on diameter (0,10 mm in A and B)

W001	3 positions double-acting	
W002	3 positions double-acting A and B to tank	
W003	3 positions double-acting A to tank B blocked	
W004	3 positions double-acting A blocked B to tank	
W005	3 positions single - acting on A	
W006	3 positions single - acting on B	
W012	4 positions double-acting with float in the 4 th position	

spools with restricted service ports				
code	circuit	restriction on diameter (mm)	section (mm ²)	hydraulic schema
J10	A-B IN T	0,10	2,66	
K10	A IN T	0,10	2,66	
Y10	B IN T	0,10	2,66	



Depending on the inlet flow, it is possible to choose appropriate spool sizes.
Spools type "E" are available with direct electric control H021, H022 and H024.

CODE	SPOOL TYPE AVAILABLE			
	spool 45 l/min inlet flow	spool 30 l/min inlet flow	spool 15 l/min inlet flow	Solenoid operated spool
	A	B	C	E
W001	W001A	W001B	W001C	W001E
W002	W002A	W002B	W002C	W002E
W003	W003A	W003A	W003C	
W004	W004A	W004A	W004C	
W005	W005A	W005B		
W006	W006A	W006B		
W012	W012A			

NOTE:

- W012, W013, spools need a special machining on the valve body.
- Float spool (W012) need special detent kit (F005).
- Different spools are available on request.

Plaease contact our Sales department for more information.



Spool actuation classification

code	description	dimensions	configuration
H001	Protected lever		
H002	Protected lever rotated 180°		
H004	Control without lever		
H019	Protected lever with stroke limiter		
H020	Protected lever rotated 180° with stroke limiter		
H348	Protected lever 180° with attachment rotated 180°		
H349	Protected lever rotated 90° inlet side		
H350	Protected lever rotated 90° outlet side		



Direct electrical control classification

code	description	dimensions
<p>H036 leave out the spool return action code</p>	<p>Direct electric control 12 Vdc (45W - 3,75 A)</p>	
<p>H037 leave out the spool return action code</p>	<p>Direct electric control 24 Vdc (45W - 1,88 A)</p>	

type	M45	
Rated voltage	12 VDC	24 VDC
Rated current	3,75 A	1,88 A
Rated power	45 W	
Permitted working voltage	±10% Nominal	
Max ambient temperature	+40°C	
Max oil temperature	+80°C	
Operation time	S1 (100%)	
Protection degree	IP65	
Insulation degree	H	
Standard connector	DIN 43650	
Spool stroke	2,5 + 2,5 mm	

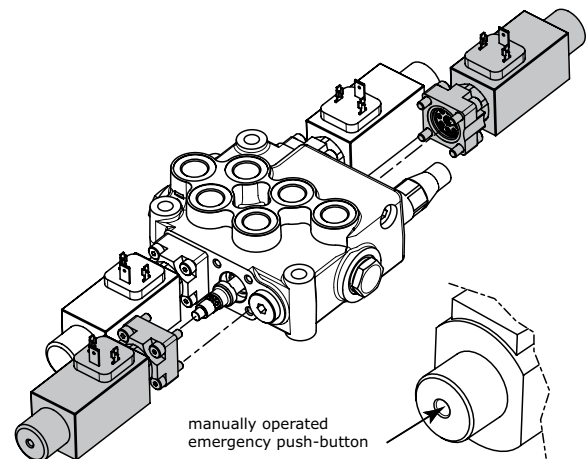

The H036 and H037 direct electric controls come as two kits each including a: spring, solenoid and adapter. The Direct electric controls use a type E special spool and a type special body. The ON-OFF Electric Control kit includes a manually operated emergency push-button.

Operating limit curve

Data detected after voltage decrease equal to 28% of the rated value (conditions occurring with coil under stabilization temperature conditions with rated voltage reduced by 10%).

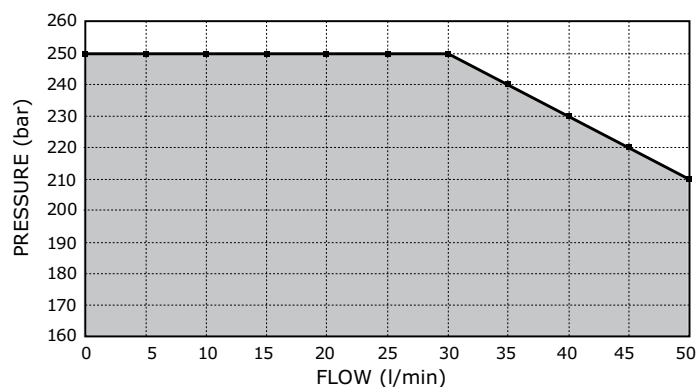



Joystick control classification

The configuration of joystick control interests always two working sections with relative four ports:

A1 – B1 – A2 - B2.

For convention:

- section 1 is the first invested from the flow of the oil: it depends from the right or left inlet of the control valve
- Port A = spool action side
- Port B = spool return action side

The position of the fulcrum is identified by a code and stands in four configurations as shown in the following table:

Fulcrum Inlet side	FULCRUM 1 st section	FULCRUM 2 nd section
RIGHT INLET	<p>H009</p> <p>Right side inlet fulcrum on 1st section (compulsory code for second section: H120)</p>	<p>H010</p> <p>Right side inlet fulcrum on 2nd section (compulsory code for first section: H120)</p>
	<p>H011</p> <p>Left side inlet fulcrum on 1st section (compulsory code for second section: H120)</p>	<p>H012</p> <p>Left side inlet fulcrum on 2nd section (compulsory code for first section: H120)</p>
LEFT INLET		

The second section concerned the configuration of the joystick control is always identified with code H120. Lever has to be ordered separately.



Spool return action classification - Springs load values

Spool return kits have three different spring types; following the codes depending on spring loads.

Spring type			
Type - Code	A (standard spring)	B (soft spring)	C (heavy spring)
Preloading	130 N	100 N	140 N
End of stroke	166 N	145 N	195 N
Spool return action identification example			
Type - Code	F001A	F001B	F001C

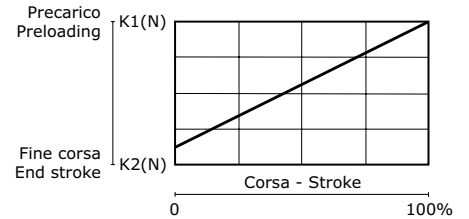

code	description	schema	dimensions	configuration
F001A F001B F001C	3 positions spring-centred spool			
F002A	3 positions spring-centred spool detent in A and B			
F003A	3 positions spring-centred spool detent in A			
F004A	3 positions spring-centred spool detent in B			
F005A	4 positions spring-centred spool detent in 4 th position (only for W012 spool)			
F009A	2 positions in A spring-centred spool			
F010A	2 positions in B spring-centred spool			
F011A	2 positions detent in A spring-centred spool			
F012A	2 positions detent in B spring-centred spool			



code	description	schema	dimensions	configuration
F013A	3 positions spring-centred spool prearrangement dual command			
F014A	3 positions spring-centred spool with stroke limiter			
F149	3 positions detent without return spring			

Pneumatic control classification

code	description	schema	dimensions	configuration
F020A	Pneumatic control ON - OFF		<p>Proportional control with port BSP: G 1/8</p>	
F021A	Pneumatic control ON - OFF rotated 180°			
F022A	Proportional Pneumatic control			
F023A	Proportional Pneumatic control rotated 180°			



Load limit classification

code	description	schema	dimensions	configuration
F024A F024C	Load limit in A and B			
F025A F025C	Load limit in A and B rotated 180°			
F026A F026C	Load limit in A			
F027A F027C	Load limit in A rotated 180°			
F028A F028C	Load limit in B			
F029A F029C	Load limit in B rotated 180°			

NOTE: on request is available the load limit with dual control; for more informations please contact our Commercial Dept.



Electrical load limit kit classification

ELECTRICAL LOAD LIMIT KIT SPECIFICATIONS			
Power supply	Contacts capacity	Protection degree	temperature range
12 vdc	3 A	IP 65	da -25°C a +90°C
24 vdc	1,5 A		

Operational diagram

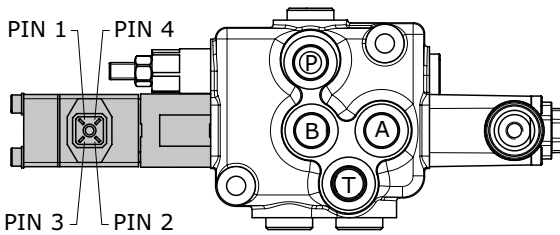

CONTROL in A e B = connect PIN 1 - 4 and 2 - 3
CONTROL in A = connect PIN2 - 3
CONTROL in B = connect PIN 1 - 4

Wiring diagram

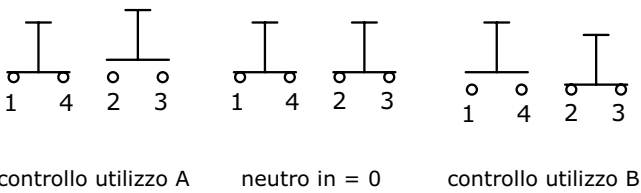

In case of inductive loads it is advisable to connect the terminals of the workport (solenoid) to a 200 VDC - 3A diode.

code	description	dimensions	configuration
F0360	Electrical load limit (normally closed contacts)		
F0370	Electrical load limit rotated 180° (normally closed contacts)		
F0450	Electrical load limit (normally open contacts)		
F0460	Electrical load limit rotated 180° (normally open contacts)		

NOTE: a HIRSCHMANN female connector, type G4 W1F, is available on request (code 413000045, to be ordered separately).



Electrohydraulic control specifications

Operating temperature range	-20°C / +80°C
Max inlet pressure	350 bar
Reduced pressure	16 bar
Back pressure on (T)	3 bar
Filtering degree	25 μ assoluti
Raccommended pilot pipe size	Ø 6 mm - G 1/4

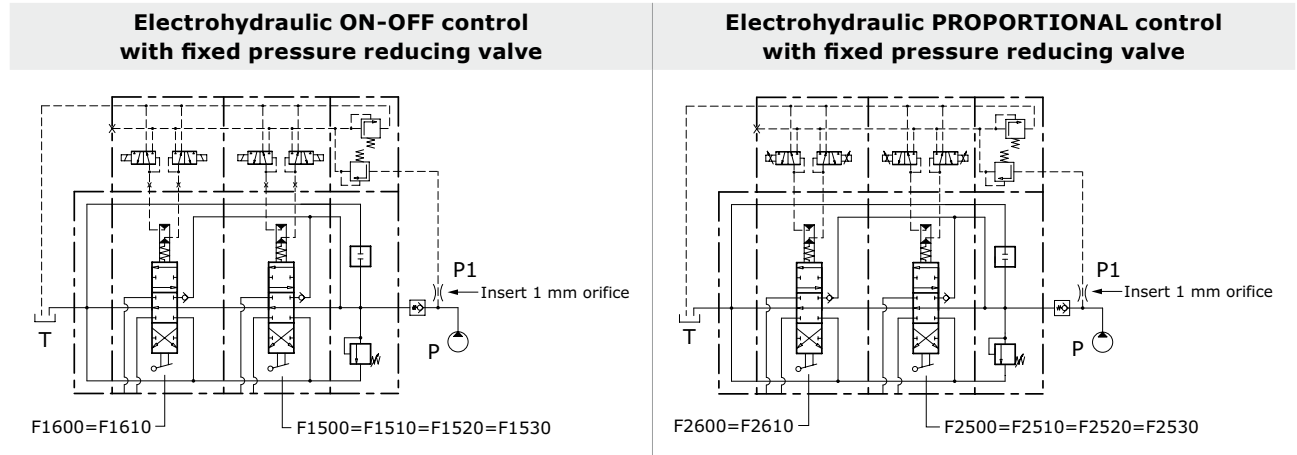

Proportional control kit, mechanically retrooperated, allows the maximum precision of positioning, limiting the hysteresis. The control is operated with PWM control of the current. PWM frequency suggest: 60-80 Hz

REGULATION CURRENTS			
Nominal voltage (V)	Resistance R ₂₀ (Ohm)	Current min (A)	Current max (A)
12 vdc	3,7	0,9	1,7
24 vdc	15,5	0,45	0,85

Electrohydraulic control classification

code	description	dimensions	configuration
F1600	3 positions electrohydraulic control ON - OFF 12 Vdc		
F1610	3 positions electrohydraulic control ON - OFF 24 Vdc		
F2600	3 positions electrohydraulic control PROPORTIONAL 12 Vdc		
F2610	3 positions electrohydraulic control PROPORTIONAL 24 Vdc		

Electrohydraulic ON-OFF control is stackable with electrohydraulic PROPORTIONAL control (F2600 = F2610). Control kit already includes orifice to make spool displacement more gradual.

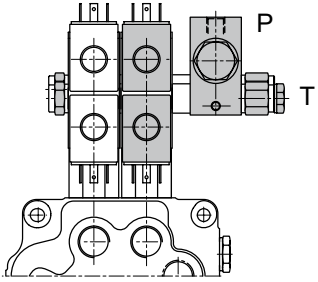
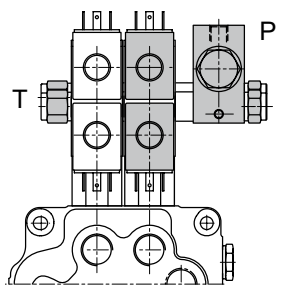

Electrohydraulic control with fixed pressure reducing valve classification

code	description	configuration
F1500	Electrohydraulic control ON - OFF (fixed pressure reducing valve) P - T inlet side (12 vdc)	 <p>Port BSP (P - T) = G 1/4 Port UNF (P - T) = 9/16"18 UNF</p>
F1510	Electrohydraulic control ON - OFF (fixed pressure reducing valve) P - T inlet side (24 vdc)	
F2500	Electrohydraulic control PROPORTIONAL (fixed pressure reducing valve) P - T inlet side (12 vdc)	
F2510	Electrohydraulic control PROPORTIONAL (fixed pressure reducing valve) P - T inlet side (24 vdc)	
F1520	Electrohydraulic control ON - OFF (fixed pressure reducing valve) P inlet - T outlet (12 vdc)	 <p>Port BSP (P - T) = G 1/4 Port UNF (P - T) = 9/16"18 UNF</p>
F1530	Electrohydraulic control ON - OFF (fixed pressure reducing valve) P inlet - T outlet (24 vdc)	
F2520	Electrohydraulic control PROPORTIONAL (fixed pressure reducing valve) P inlet - T outlet (12 vdc)	
F2530	Electrohydraulic control PROPORTIONAL (fixed pressure reducing valve) P inlet - T outlet (24 vdc)	

Control tie rod assembly

The length of the control tie rod, will change depending on the section numbers; in this way it will be easy to install in the right way the sections and avoid any misassembly. Each kit is composed by 2 tie rods, 2 plugs, 2 connection ports and spacers according to the section number.

NOTE: the control tie rod kit has always to be ordered separately.

Reducing valve, combined with electrohydraulic control kit has to be calculated as a normal working section.

ORDER EXAMPLE:

Complete valves with 3 sections F1600 requires a complete tie-rod kit /3.

Complete valves with 2 sections F1600 and 1 section with F1500 (reducing valve) requires a complete tie-rod kit /4.

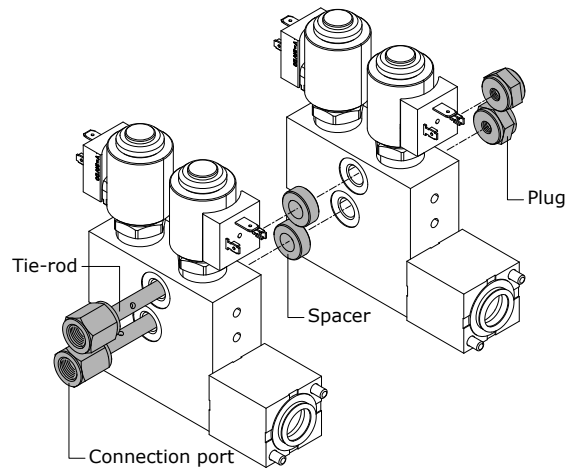

Order code fixed pressure reducing valve:

915000303 = reducing valve for BSP ports

915000312 = reducing valve for UNF ports

Order code for control tie rod (BSP):

320103001 = control tie rod /1

320102001 = control tie rod /2

320102002 = control tie rod /3

320102003 = control tie rod /4

320102004 = control tie rod /5

320102005 = control tie rod /6

320102006 = control tie rod /7



OUTLET ARRANGEMENT

This code indicates characteristics for outlet section: ports position and thread, simple T port or HPCO connection. It is possible to have simple T port or two ports configuration for HPCO connection: HPCO allows to extend by-pass channel and connect to a second valve. T ports dimensions and threads depends on the valve size.

Order example - version 1 Outlet

M45/1: IR 301 150 W001A H001 F001A **MJ A G03**

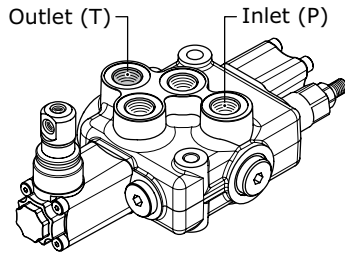

OUTLET ARRANGEMENT:

- 1. **MJ** outlet type
- 2. **A G03** outlet position and available thread type

Rif.	Code	Description	Page
1	MJ	Monoblock valve with single outlet (T) right-side inlet (P)	
	MK	Monoblock valve with single outlet (T) left-side inlet (P)	
2	A G03	P - T on the top / top ports A - B (thread G 3/8)	22
	A U03	P - T on the top / top ports A - B (thread 3/4"-16 UNF)	
	C G03	P - T on sides / top ports A - B (thread G 3/8)	
	C U03	P - T on sides / top ports A - B (thread 3/4"-16 UNF)	

Order example - HPCO version Outlet

M45/1: IR 301 150 W001A H001 F001A **MM U G03**

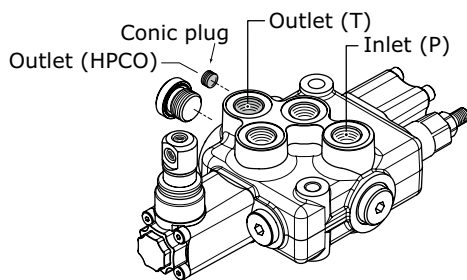

OUTLET ARRANGEMENT:

- 1. **MM** outlet type
- 2. **U G03** outlet position and available thread type

Rif.	Code	Description	Page
1	MM	Monoblock valve with two return (T - HPCO) right-side inlet (P)	
	MN	Monoblock valve with two return (T - HPCO) left-side inlet (P)	
2	T G03	P - T - HPCO on sides / top ports A - B (thread G 3/8)	23
	T U03	P - T - HPCO on sides / top ports A - B (thread 3/4"-16 UNF)	
	U G03	P - T on the top / HPCO on side / top ports A - B (thread G 3/8)	
	U U03	P - T on the top / HPCO on side / top ports A - B (thread 3/4"-16 UNF)	



Outlet with single tank classification

outlet identification

MJ

monoblock valve with single outlet (T)
right-side inlet (P)

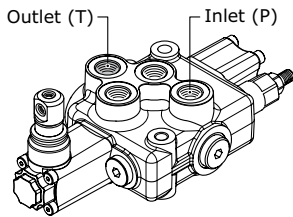
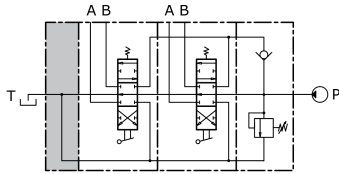

MK

monoblock valve with single outlet (T)
left-side inlet (P)

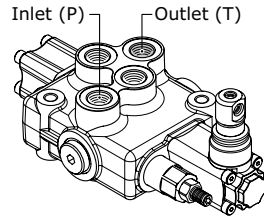
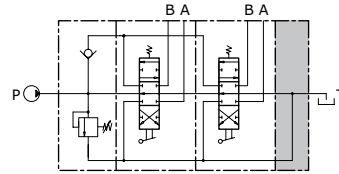

Outlet position

outlet combination and thread available

A G03

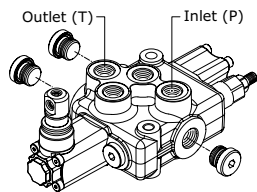

P - T on the top
top ports A - B
(thread G 3/8)

A U03

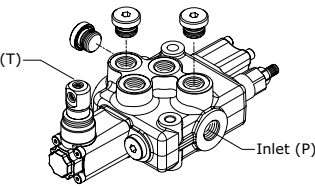

P - T on the top
top ports A - B
(thread 3/4" - 16 UNF)

C G03

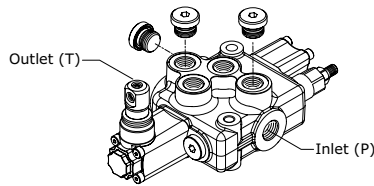

P - T on sides
top ports A - B
(thread G 3/8)

C U03

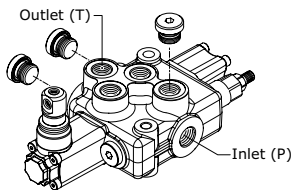

P - T on sides
top ports A - B
(thread 3/4" - 16 UNF)

K G03

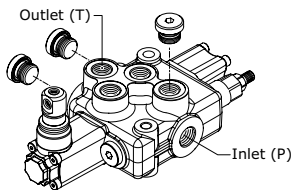

P on side - T on the top
top ports A - B
(thread G 3/8)

K U03

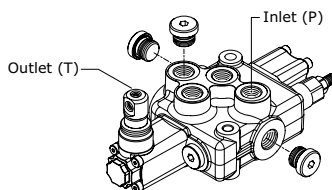

P on side - T on the top
top ports A - B
(thread 3/4" - 16 UNF)

L G03

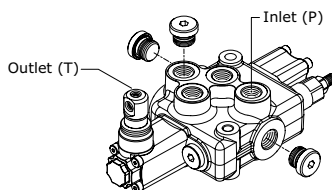

P on the top - T on side
top ports A - B
(thread G 3/8)

L U03



P on the top - T on side
top ports A - B
(thread 3/4" - 16 UNF)

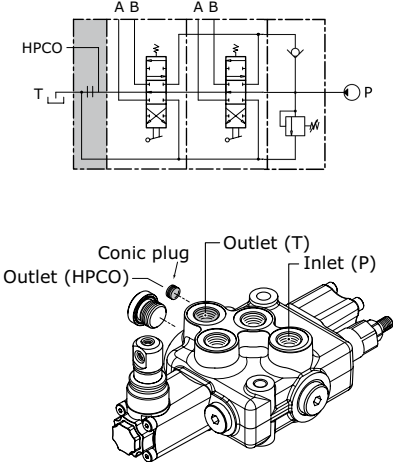
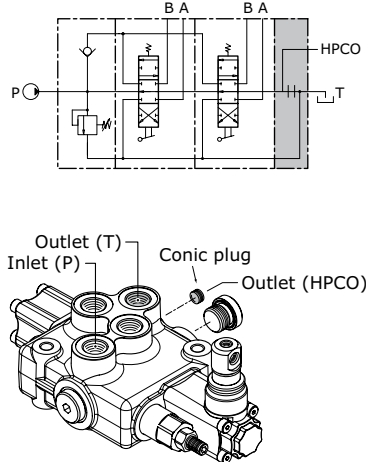

Outlet with two tanks classification

outlet identification	
MM	<p>monoblock valve with two return (T-HPCO) right-side inlet (P)</p> 
MN	<p>monoblock valve with two return (T-HPCO) left-side inlet (P)</p> 

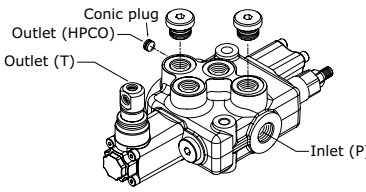
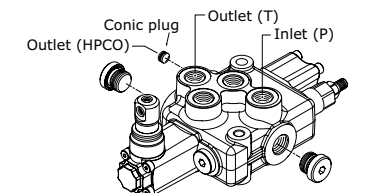
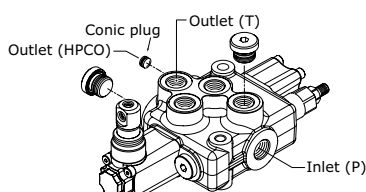
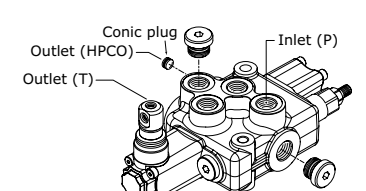
Outlet position

outlet combination and thread available	
T G03	 <p>P-T-HPCO on sides top ports A - B (thread G 3/8)</p>
T U03	 <p>P-T-HPCO on sides top ports A - B (thread 3/4" - 16 UNF)</p>
U G03	 <p>P-T on the top - HPCO on side top ports A - B (thread G 3/8)</p>
U U03	 <p>P-T on the top - HPCO on side top ports A - B (thread 3/4" - 16 UNF)</p>
V G03	 <p>P-HPCO on side - T on the top top ports A - B (thread G 3/8)</p>
V U03	<p>P-HPCO on side - T on the top top ports A - B (thread 3/4" - 16 UNF)</p>
X G03	<p>P on the top - T-HPCO on sides top ports A - B (thread G 3/8)</p>
X U03	<p>P on the top - T-HPCO on sides top ports A - B (thread 3/4" - 16 UNF)</p>



CARRY-OVER CONNECTION (HPCO)

This option, available on all M45, allows the sectional valve to feed a second valve, by extending the free flow channel. In this configuration, the valve need a separated port for connection to tank.

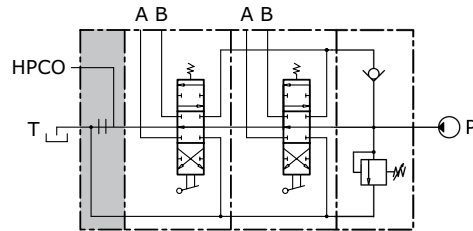

It is possible to transform monoblock valve from standard to HPCO version just by ordering the appropriate conic plug:

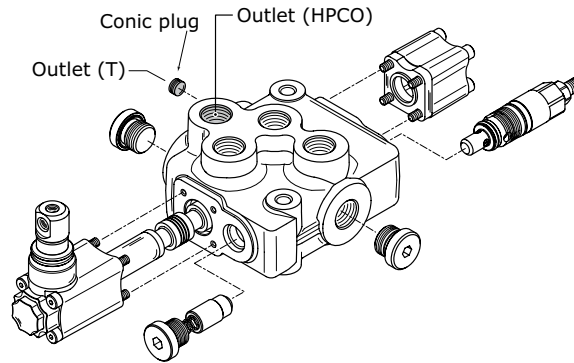

code (HPCO Plug identification)	description	q.ty
413010210	conic plug 1/4" x 6,5	1



M45 SPARE PARTS LIST

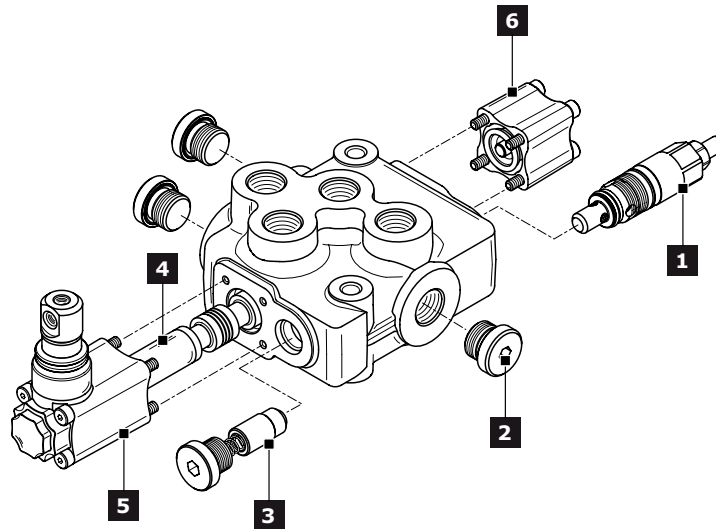

The following order codes of spools, actuation kits and return springs are available only M45 right inlet. The inlet version uses different codes.

Ref.	Description	Order code	Q.ty	Code	Note
1	Direct acting pressure relief valve (*)	71628	1	-	Setting: 100 bar
		71708			Setting: 200 bar
		74143			Setting: 300 bar
	Relief valve plugged	430172001	1		
2	Plug kit (G 3/8)	430000018	1	G03	
	Plug kit (3/4" - 16 UNF)	300001006		U03	
3	Check valve	320272001	1		
4	3 positions double-acting spool	421272002	1	W001A	flow: 45 l/min
		421272011		W001B	flow: 30 l/min
		421272003		W001C	flow: 15 l/min
	Assembly spool	430372001		W001E	for direct electrical control
	3 positions double-acting A and B to tank spool	421272004		W002A	flow: 45 l/min
		421272013		W002B	flow: 30 l/min
		421272032		W002C	flow: 15 l/min
		430372002		W002E	for direct electrical control
	3 positions single-acting on A	421272007		W005A	flow: 45 l/min
	3 positions single-acting on B	421272008		W006A	flow: 45 l/min
4 positions double-acting with float in the 4 th pos.	421272030	W012A	flow: 45 l/min		
5	Protected lever	320372001	1	H001 = H002	only for W012 spool
		320372005			
	Control without lever	320372002		H004	
		320372004			
	Protected lever with stroke limiter	320373003		H019 = H020	
	Joystick control	320672001		H009 = H012	
320672002		H010 = H011			
Direct electrical control (12 vdc)	320072020	2	H036	only for spool type "E"	
Direct electrical control (24 vdc)	320072021		H037		
6	3 position spring centred spool	320772001	1	F001A	
	Detent in A and B	320872007		F002A	
	Detent in A	320872008		F003A	
	Detent in B	320872009		F004A	
	Detent in 4 th position	320872015		F005A	only for W012 spool
	Prearrangement dual command	320772006		F013A	
	Pneumatic control ON-OFF	321172001		F020A = F021A	
	Proportional pneumatic control	321272001		F022A = F023A	BSP ports



Ref.	Description	Order code	Q.ty	Code	Note
6	Load limit in A and B	320072001		F024A = F025A	
	Load limit in A	320072003		F026A = F027A	
	Load limit in B	320072005		F028A = F029A	
	Electrical load limit (normally closed contacts)	320072007		F0360 = F0370	
	Electrical load limit (normally open contacts)	320072008		F0450 = F0460	
	Electrohydraulic ON - OFF (12 vdc)	321472003		F1600	
	Electrohydraulic ON - OFF (24 vdc)	321472004		F1610	
	Electrohydraulic Proportional (12 vdc)	322072001	1	F2600	
	Electrohydraulic Proportional (24 vdc)	322072002		F2610	
	Electrohydraulic ON - OFF (12 vdc) with reducing valve	321472007		F1500 = F1520	BSP ports
	Electrohydraulic ON - OFF (24 vdc) with reducing valve	321472008		F1510 = F1530	
	Electrohydraulic Proportional (12 vdc) with reducing valve	322072003		F2500 = F2520	UNF ports
	Electrohydraulic Proportional (24 vdc) with reducing valve	322072004		F2510 = F2530	
	Electrohydraulic Proportional (12 vdc) with reducing valve	322072005		F2500 = F2520	BSP ports
Electrohydraulic Proportional (24 vdc) with reducing valve	322072006		F2510 = F2530		



INSTALLATION

Guidelines

- Mount the control valve securely to a flat surface (recommended 3 point fixing); at the time do not use a hammer to positioning by hitting.
- When handling the monoblock valve, be careful not hold the pilot cover or return spring cap of the spool or accessory valves such as main relief valves.
- Clean piping materials sufficiently before use.
- Make sure to prevent the port openings from being entered with dust or foreign matters.
- Tighten the port connectors surely with the recommended fastening torques.
- Do not direct the jet of a pressure washing unit directly to the valve.

Fittings tightening torque (Nm)

thread type	port P	Port A - B	Port T/HPCO
BSP (ISO - 228)	G 3/8	G 3/8	G 3/8
with rubber sealing (DIN 3869)	40	40	40
with copper or steel and rubber washer	40	40	40
UN-UNF (ISO - 725)	3/4" - 16 UNF	3/4" - 16 UNF	3/4" - 16 UNF
with O.R.	40	40	40

General Clamping torque (Nm)

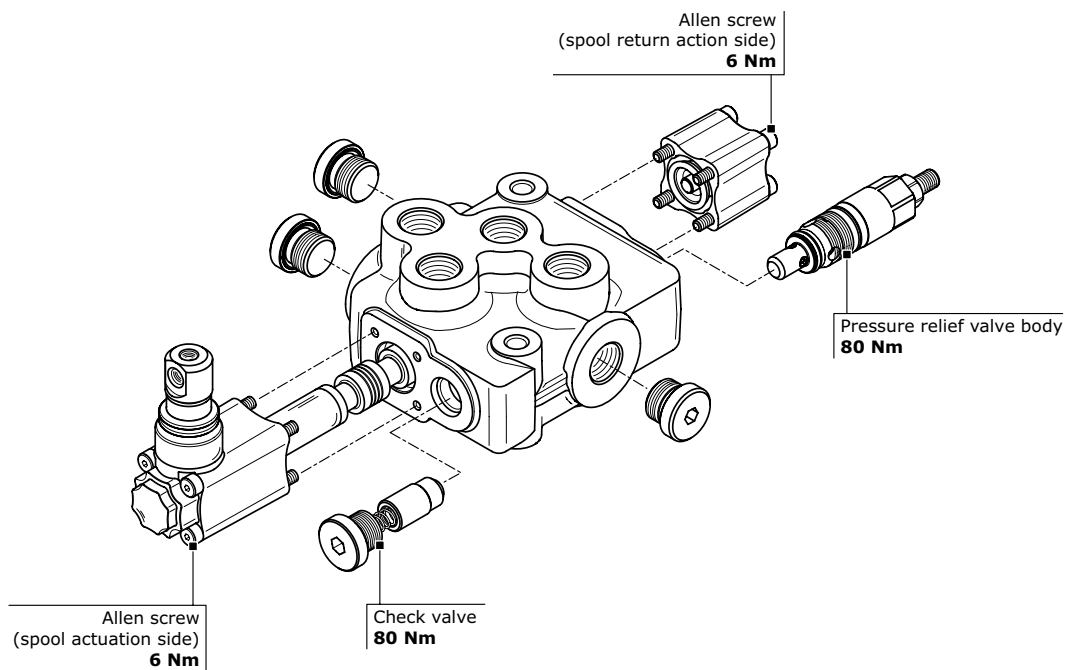



Dimensions - Thread codes

The connection ports size is indicated by an ordering code common for all Hydrocontrol products. Following table shows all available connections.

METRIC THREAD (ISO 9974-1)			
Type	M18x1,5	M22x1,5	M27x2
Code	M01	M02	M03

BSP THREAD (ISO 1179-1)								
Type	1/4"	3/8"	1/2"	3/4"	1"	1"1/4	1"1/2	2"
Code	G02	G03	G04	G05	G06	G07	G08	G09

UN / UNF THREAD (ISO 11926-1)						
Type	9/16" 18 UNF SAE6	3/4" 16 UNF SAE8	7/8" 14 UNF SAE10	1"1/16 12 UNF SAE12	1"5/16 12 UNF SAE16	1"5/8 12 UNF SAE20
Code	U02	U03	U04	U05	U06	U07

Dimensions - SAE Flange codes

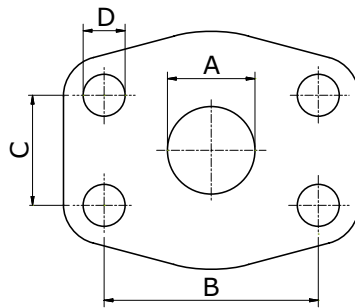

SAE / 3000 FLANGE (ISO 6162-1)												
Type	3/4" (MA)	3/4" (UNC)	1" (MA)	1" (UNC)	1"1/4 (MA)	1"1/4 (UNC)	1"1/2 (MA)	1"1/2 (UNC)	2" (MA)	2" (UNC)	3" (MA)	3" (UNC)
Code	S03	S04	S05	S06	S07	S08	S09	S10	S11	S12	S15	S16
A	19	19	25	25	32	32	38	38	51	51	76	76
B	47,6	47,6	52,4	52,4	58,7	58,7	69,9	69,9	77,8	77,8	106,4	106,4
C	22,3	22,3	26,2	26,2	30,2	30,2	35,7	35,7	42,9	42,9	61,9	61,9
D	M10	3/8-16	M10	3/8-16	M10	7/16-14	M12	1/2-13	M12	1/2-13	M16	5/8-11

SAE / 6000 FLANGE (ISO 6162-2)								
Type	3/4" (MA)	3/4" (UNC)	1" (MA)	1" (UNC)	1"1/4 (MA)	1"1/4 (UNC)	1"1/2 (MA)	1"1/2 (UNC)
Code	S33	S34	S35	S36	S37	S38	S39	S40
A	19	19	25	25	32	32	38	38
B	50,8	50,8	57,2	57,2	66,6	66,6	79,3	79,3
C	23,8	23,8	27,8	27,8	31,8	31,8	36,5	36,5
D	M10	3/8-16	M12	7/16-14	M14	1/2-13	M16	5/8-11



GENERAL CONDITIONS AND PATENTS

Product identification

All Hydrocontrol products have an identifying plate placed in specific position.

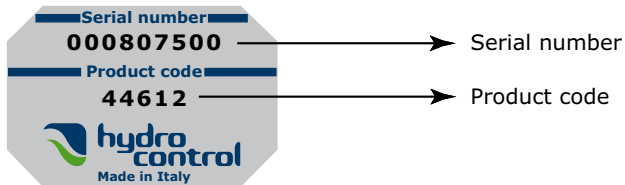

Serial number:

It univocally identifies the physical valve: this provides an easy way to find all sales and production details.

Product code:

It is a number univocally identifying the configuration and pressure settings of a valve.

Introduction

These general conditions apply to all general supplies from Hydrocontrol s.p.a., after receiving orders from the Customer. Should commercial terms such as EXW, DDP, etc be mentioned, of course the Incoterms of the International Chamber of Commerce must be referred to, according to the test existing when the general supply conditions are agreed on.

Management of orders

No Customer's order is binding to Hydrocontrol s.p.a. if Hydrocontrol s.p.a. has not confirmed the order in writing. Hydrocontrol s.p.a. commits to supplying the orders in compliance with the order confirmation that has been issued. Any disagreement with the content of the order confirmation must be communicated in writing to Hydrocontrol s.p.a. within and no later than 5 days from the delivery of the order confirmation. The Customer commits to paying for the goods supplied by Hydrocontrol s.p.a., according to the prices indicated on the order confirmation.

Payment conditions

The Parties agree on the payment terms at the beginning of the supply. The terms will be indicated on the order confirmation. Should the Customer be late with the payments, Hydrocontrol S.p.a. will be entitled to require the payment of interests on arrears based on the exiting Prime Rate increased by 2%. Should there be any payment delay, Hydrocontrol s.p.a. will be entitled not to process the Customer's purchase order, even if it has already been confirmed.

Delivery and shipment

The goods are always supplied Ex Works, even when Hydrocontrol s.p.a. agrees with the Customer that the shipment, or a part of it, will be arranged by Hydrocontrol s.p.a. It is agreed that the Customer will bear the risk of goods deterioration or damaging from the moment the goods are handed by Hydrocontrol s.p.a. to the first carrier.

Product characteristics

Hydrocontrol s.p.a. commits to supplying good quality products, compliant with the technical specifications declared on the technical tables and on the catalogue. Hydrocontrol s.p.a, even without notice, at its own discretion, reserves the right to modify the products as necessary, without these changes altering the main characteristics of the products.

Claims

Any claims about defects on delivered products (just as an example: claims about the packaging, the number, the quantity or the external product characteristics) will have to be notified to Hydrocontrol s.p.a. in writing, within and no later than 7 days from reception of the goods, otherwise the claims will be considered as null and void. Occult defects (the defects of the goods that cannot be spotted with a careful control of the goods received by the Customer), will have to be notified in writing to Hydrocontrol s.p.a. within 7 days from the discovery of the defect, and anyhow no later than 12 months from the delivery of the goods, otherwise the claim will be considered as null and void. Even in case of claim or objection, the Customer will never be entitled to suspend or delay the payments to Hydrocontrol s.p.a. for the products subject to claim or objection nor for any other supply.

**GENERAL CONDITIONS AND PATENTS****Warranty**

Should the products supplied by Hydrocontrol not be compliant or have the required quality and should this defect be due to Hydrocontrol, Hydrocontrol s.p.a. commits, at its choice, to replace or repair the faulty products, as long as the defect or lack of compliance is notified to Hydrocontrol s.p.a. in writing, as specified at point 6, within and no later than 18 months from product delivery. On the products that have been fixed or replaced in accordance with what specified above, the above-mentioned warranty applies. The 12 month duration starts from the date of repair or replacement. In case of defects, lack of quality or in case of lack of compliance for the supplied products, with the exception of fraud or serious offence, Hydrocontrol s.p.a. only commits to repairing or replacing the faulty products, according to what specified above. This warranty replaces any other Supplier's warranty or liability established by the law. This warranty excludes any other liability contractual or extra-contractual by Hydrocontrol s.p.a. on the products supplied by Hydrocontrol (as a mere example: damage refund, loss of profit, product recall campaign, etc). Hydrocontrol s.p.a. has signed a product civil liability police, with a suitable maximum coverage.

Ownership retention

The products supplied by Hydrocontrol s.p.a. will be owned by the latter until Hydrocontrol receives the complete payment for the supplied goods.

Obligation confidentiality

Hydrocontrol s.p.a. commits to not disclosing the technical and commercial information it receives from the Customer, unless this information has already been publicly disclosed.

Patents

The Customer is not allowed to use the provided Products, or a part of them, their descriptions or drawings protected or not protected by Patent or registered trademark in order to design or make similar products, unless Hydrocontrol s.p.a. previously issues its written authorization. Should Hydrocontrol s.p.a. give its written authorization, all patents, trademarks, registered designs, copyrights and intellectual property rights related or connected to the Products provided by Hydrocontrol s.p.a. will stay Hydrocontrol's property. The Customer commits to respecting the highest confidentiality.

Applicable law and court of jurisdiction

Hydrocontrol s.p.a.'s supplies are regulated by these General Supply Conditions and, for anything not defined here, by the Italian law. Any controversy related, generated or connected to the supply of Products by Hydrocontrol s.p.a., where Hydrocontrol s.p.a. is involved, will be exclusively dealt with by the Court of Bologna.

Walvoil nel mondo - Walvoil worldwide

Sede principale, Filiali e Uffici di rappresentanza
Headquarters, Subsidiaries and Representative Offices

Walvoil S.p.A. - Sede principale - Headquarters
Via Adige, 13/D . 42124 Reggio Emilia . Italy
TEL. +39 0522 932411 . info@walvoil.com . www.walvoil.com

Business Unit Hydrocontrol
Via Natale Salieri, 6 . 40024
Castel S. Pietro Terme . Bologna . Italy
TEL. +39 051 6959411

Galtech Site
Via Portella della Ginestra, 10 . 42025 Cavriago
Zona Industriale Corte Tegge . Reggio Emilia . Italy
TEL. +39 0522 932411

AUSTRALASIA . *AUSTRALASIA*
Walvoil Fluid Power Australasia Pty Ltd
13 Vanessa Way . Delahey VIC 3037 . Melbourne . Australia
TEL. +61 458 918 750 . australasia@walvoil.com

BRASILE . *BRAZIL*
Interpump Hydraulics Brasil Ltda - Walvoil Division
Gilberto de Zorzi, 525 . Forqueta Caxias do Sul (RS)
TEL. +55 54 3223 2373 . infobrasil@walvoil.com

CANADA . *CANADA*
Galtech Canada Inc.
3100, Jacob Jordan . Terrebonne . Qc J6X 4J6 . Canada
TEL. +1 450 477 1076 Ext:225 . info@galtechcanada.com

CINA . *CHINA*
Walvoil Fluid Power (Dongguan) Co. Ltd
1st Floor, the Third Factory Area, Sijia, Shijie Town, Dongguan City, Guangdong province, China.
TEL. +86 769 81816189-8020 . FAX. +86 769 81816589
info@walvoil.com.cn . www.walvoil.com.cn

COREA DEL SUD . *SOUTH KOREA*
Walvoil Fluid Power Korea Ltd.
80-15, Oseongsandan 1Ro,
Oseong-Myun, Pyungtaek, Kyungki .
Korea 451-872 . TEL. +82 31 682 6030
info@walvoil.co.kr . www.walvoil.co.kr

FRANCIA . *FRANCE*
Walvoil Fluid Power France
362 rue de Bretagne . Vritz . 44540 Vallons-de-l'Erdre
TEL. +33 2 41 94 41 06 . france@walvoil.com

INDIA . *INDIA*
Walvoil Fluid Power (India) PVT. LTD.
No. 19, 2nd Cross, 2nd Main, KIADB Industrial Area, Attibele,
Anekal Taluk, Bangalore - 562107 . TEL. +91 80 0614 24000 info@walvoil.co.in . www.walvoil.co.in

U.S.A. . *U.S.A.*
Walvoil Fluid Power Corp.
4111 North Garnett Tulsa, OK 74116, USA
TEL. +1 918 858 7100 . info@walvoilusa.com .
www.walvoilusa.com

Walvoil Fluid Power Corp. Hydrocontrol Business Unit
1109, Technology Drive . Red Wing . MN 55066 . U.S.A.
TEL. +1 651 212 6400 . info@walvoilusa.com .
www.walvoilusa.com

1st edition M45.01

www.hydrocontrol-inc.com



D1WHEA01E

