

# DVS10

SECTIONAL VALVE



TECHNICAL CATALOGUE

A member of



1800-OILSOL  
1800-645765

<https://oilsolutions.com.au/>

[sales@oilsolutions.com.au](mailto:sales@oilsolutions.com.au)

**2<sup>nd</sup> edition DVS10.01**

---

*This catalogue shows the product in the most standard configurations.  
Please contact our Sales Dpt. for more detailed information or special requests.*

**WARNING!**

*All specifications of this catalogue refer to the standard product at this date.  
Walvoil, oriented to a continuous improvement, reserves the right to  
discontinue, modify or revise the specifications, without notice.*

**WALVOIL IS NOT RESPONSIBLE FOR ANY DAMAGE CAUSED BY AN  
INCORRECT USE OF THE PRODUCT.**



## Applications

DVS10 is a new family in the broad range of Hydrocontrol sectional valves.

Specifically designed for mini skid loaders and mini dumper applications, DVS10 can include different components normally assembled on the machine.

The Valve has very exact control characteristics, smooth and precise in operation, with compact light weight design. Numerous configurations and solutions are possible.

Working sections have auxiliary valves and a broad range of interchangeable spools.





**QUICK REFERENCE GUIDE**

<b>GENERAL SPECIFICATION</b>	<b>D9</b>	<b>D3M</b>	<b>DVS10</b>	<b>D4</b>	<b>D6</b>	<b>D16</b>	<b>D12</b>	<b>DVS20</b>	<b>D20</b>	<b>D25</b>	<b>D40</b>
Working sections number	1-12	1-12	1-12	1-12	1-12	1-12	1-12	1-12	1-12	1-12	1-10
<b>CIRCUIT</b>											
Parallel	•	•	•	•	•	•	•	•	•	•	•
Series	•	•	•	•	•	•	•		•	•	
Tandem	•	•	•	•	•	•		•	•		
Parallel circuit stroke (mm)	6	5	6	6	7	7	9,5	9,5	9,5	12	15
Series circuit stroke (mm)	6	5	6	6	5	7	6,5		6,5	8,5	
Float spool extra stroke (mm)	5	5	5	5,5	6	7	7	7	7	9,5	10
Spools pitch (mm)	31	38	35	40	46	46	56	56	64	75	91
<b>RATED FLOW</b>											
Max recommended flow rate (l/min)	35	55	45	80	100	150	180	250	250	380	700
Max recommended flow rate (GPM)	10	15	12	22	27	40	48	67	67	100	185
<b>RATED PRESSURE</b>											
Max working pressure (bar)	350	350	350	350	350	350	350	250	350	350	350
Max working pressure (PSI)	5000	5000	5000	5000	5000	5000	5000	4000	5000	5000	5000

<b>OPTION CHART</b>	<b>D9</b>	<b>D3M</b>	<b>DVS10</b>	<b>D4</b>	<b>D6</b>	<b>D16</b>	<b>D12</b>	<b>DVS20</b>	<b>D20</b>	<b>D25</b>	<b>D40</b>
Direct acting pressure relief valve	•	•	•	•							
Pilot operated pressure relief valve		•		•	•	•	•	•	•	•	•
2 stage pilot operated relief valve		•		•	•	•	•		•	•	•
Externally piloted valve	•	•	•	•	•	•	•		•	•	•
Solenoid dump valve (12 Vdc)	•	•	•	•	•	•	•				
Solenoid dump valve (24 Vdc)	•	•	•	•	•	•	•				
Main anticavitation check valve		•		•	•	•	•	•	•	•	•
Clamping valve		•	•	•							
<b>SPOOL ACTUATION</b>											
Manual control	•	•	•	•	•	•	•	•	•	•	•
Without lever	•	•	•	•	•	•	•	•	•	•	•
90° joystick control		•	•	•	•	•					
Hydraulic control	•	•	•	•	•	•	•	•	•	•	•
Direct electric control (12-24 Vdc)		•		•							
<b>SPOOL RETURN ACTION</b>											
Spring return	•	•	•	•	•	•	•	•	•	•	•
Detent in A - in B - in A/B	•	•	•	•	•	•	•	•	•	•	•
Detent in 4 <sup>th</sup> position	•	•	•	•	•	•	•	•	•	•	•
Arrangement for dual control	•	•		•	•	•	•		•		
Hydraulic load limit	•	•		•	•	•					
Pneumatic control ON - OFF		•	•	•	•	•	•	•	•		
Proportional pneumatic control		•	•	•	•	•	•	•	•		
Electrical load limit	•	•		•	•	•					
Electrohydraulic control ON-OFF (12-24 Vdc)		•	•	•	•	•	•	•	•		
Electrohydraulic control PROP. (12-24 Vdc)		•	•	•	•	•	•	•	•		
Electropneumatic control (12-24 Vdc)		•	•	•	•	•	•		•		
<b>AUXILIARY VALVES</b>											
Antishock valve	•	•	•	•	•	•	•	•	•	•	•
Anticavitation valve	•	•	•	•	•	•	•	•	•	•	•
Combined valve	•	•	•		•	•	•		•	•	•
Pilot combined valve						•		•	•	•	•



**GENERAL INDEX**

<b>4</b>	<b>General specifications</b> Standard working conditions Fluid options
<b>5</b>	<b>Order example</b> Standard thread Tie-rod kit classification Painting
<b>7</b>	<b>Dimensions</b>
<b>8</b>	<b>Typical curves</b> Pressure drop (P - T) Pressure drop (P - A/B) Pressure drop (A/B - T) Direct relief valve curve Antishock valve curve Combined valve curve
<b>10</b>	<b>Inlet Section</b> Order example Inlet side classification Valve identification Valve arrangement Inlet position and available thread type
<b>13</b>	<b>Working section</b> Order example Spool identification Spool actuation classification Spool return action classification - Spring load values Work section identification Auxiliary valves identification
<b>24</b>	<b>Outlet section (version 1 outlet)</b> Order example <b>Outlet section (HPCO version outlet)</b> Order example - HPCO version outlet Carry-over connection (HPCO)
<b>28</b>	<b>DVS10 Spare parts list</b> Gasket kits
<b>31</b>	<b>Installation</b>
<b>33</b>	<b>General conditions and patents</b>



## GENERAL SPECIFICATIONS

## Standard working conditions

Description	Value
Ambient operating temperature range	-40°C / +60°C
Kinematic viscosity range	10 ÷ 300 cSt
Max contamination level	9 (NAS 1638) - 20/18/15 (ISO 4406:1999)
Recommended filtration level	$\beta_{10} > 75$ (ISO 16889:2008)
Internal filter (on electroproportional valves pilot line)	30 $\mu\text{m}$

All information and diagrams in this catalogue refer to a mineral base oil VG46 at 50°C temperature (32 cSt kinematic viscosity)

## Fluid options

Types of fluid (according to ISO 6743/4) Oil and Solutions	Temperature (°C)		Compatible gasket
	min	max	
Mineral Oil HL, HM (or HLP acc. to DIN 51524)	-25	+80	NBR
Oil in water emulsions HFA	+5	+55	NBR
Water in oil emulsions HFB	+5	+55	NBR
Polyglycol-based aqueous solution HFC	-10	+60	NBR

For special applications and different fluids, please call our Technical Department.



**ORDER EXAMPLE**

DVS10/1: IR 001 150 A U03 W001A H001 F001A RP U03 01 PA 100 05 PB TJ A U04

**TYPE:**  
 DVS10: product type  
 /1: working section number

- 1) INLET ARRANGEMENT: pag. 10**  
**IR 001** inlet side and valve type  
**150** setting (bar)  
**A U03** inlet position and available thread type

- 2) WORK SECTION ARRANGEMENT: pag. 13**  
**W001A** spool type  
**H001** spool actuation type  
**F001A** spool return action type  
**RP U03** type and thread section  
**01 PA 100** auxiliary valve (port A)  
**05 PB** auxiliary valve (port B)

- 3) OUTLET ARRANGEMENT: pag. 24**  
**TJ** outlet type  
**A U04** outlet position and available thread type

Ordering row 2 must be repeated for every work section

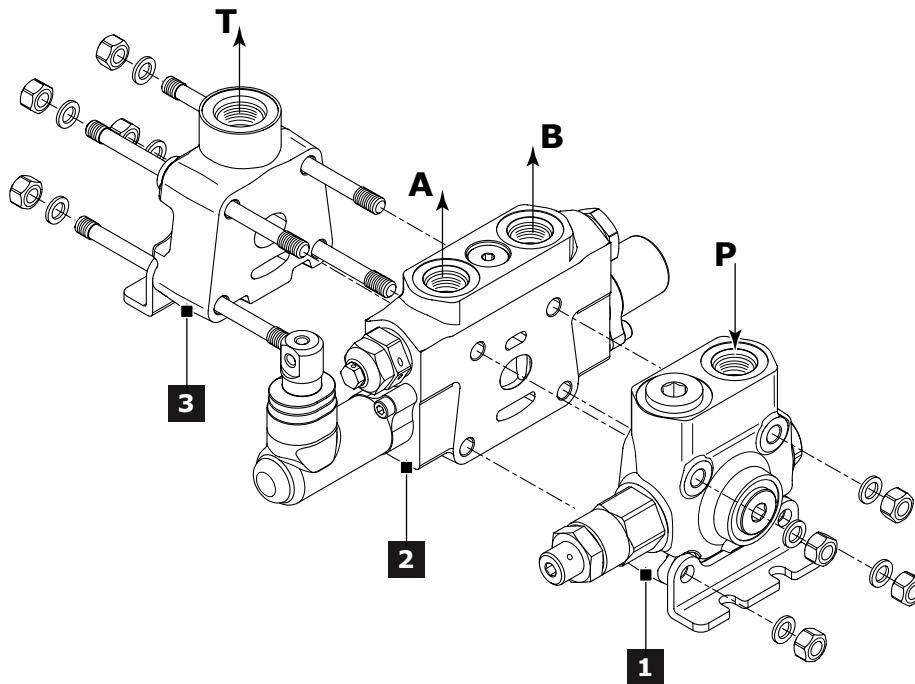

**Standard thread**

The connection ports size is indicated by an ordering code common for all Hydrocontrol products. Following table shows all available connections; for ordering code refer to table on page 32.

Ports	BSP (ISO - 228)	Code	UN-UNF (ISO - 725)	Code
<b>Inlet Port (P)</b>	G 3/8 - G 1/2	<b>G03 - G04</b>	3/4" - 16 UNF / 7/8" - 14 UNF	<b>U03 - U04</b>
<b>Ports (A - B)</b>	G 3/8	<b>G03</b>	3/4" - 16 UNF	<b>U03</b>
<b>Outlet (T) - Carry over (HPCO)</b>	G 1/2	<b>G04</b>	7/8" - 14 UNF	<b>U04</b>
<b>Hydraulic Pilot</b>	G 1/4	<b>G02</b>	9/16" - 18 UNF	
<b>Pneumatic Pilot</b>	G 1/8	-	NPTF 1/8-27	



**Tie-rod kit classification (appendix "A")**

Tie rod kit allows the correct assembly of sectional valves. Tie rod's length depends on the number of sections; each valve is assembled with tie rod kits including a tie rod, two nuts and two washers. DVSD10 requires 4 tie-rod kits.

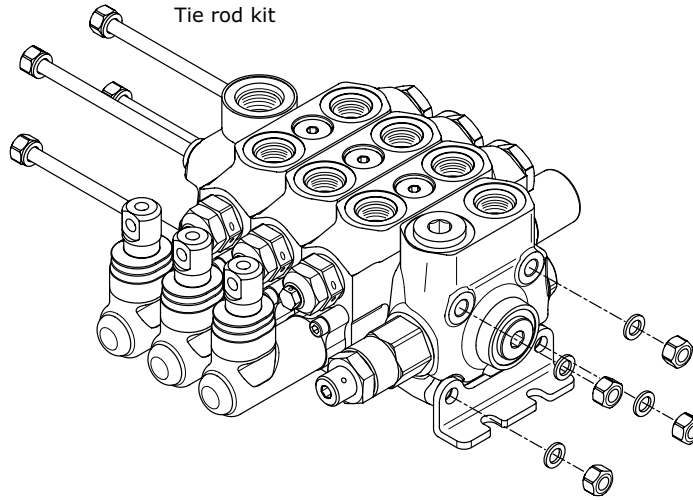

Tie rod kit	Order Code	Lenght (mm)	Clamping Torque (Nm)	Quantity
DVS10/1	300166001	135		
DVS10/2	300166002	170		
DVS10/3	300166003	205		
DVS10/4	300166004	240		
DVS10/5	300166005	275		
DVS10/6	300166006	310	25	4
DVS10/7	300166007	345		
DVS10/8	300166008	380		
DVS10/9	300166009	415		
DVS10/10	300166010	450		
DVS10/11	300166011	485		
DVS10/12	300166012	520		

**Painting**

On request, all Hydrocontrol valves can be delivered painted (RAL 9005 black primer).

**Order example of DVS10/1 painted:**

DVS10/1  
IR 001 150 A U03  
W001A H001 F001A RP U03 01 PA 100 05 PB  
TJ A U04  
**P006/1 N10**

The painting is indicated with the following value:

**P006 - /1 - N10**





**DIMENSIONS**

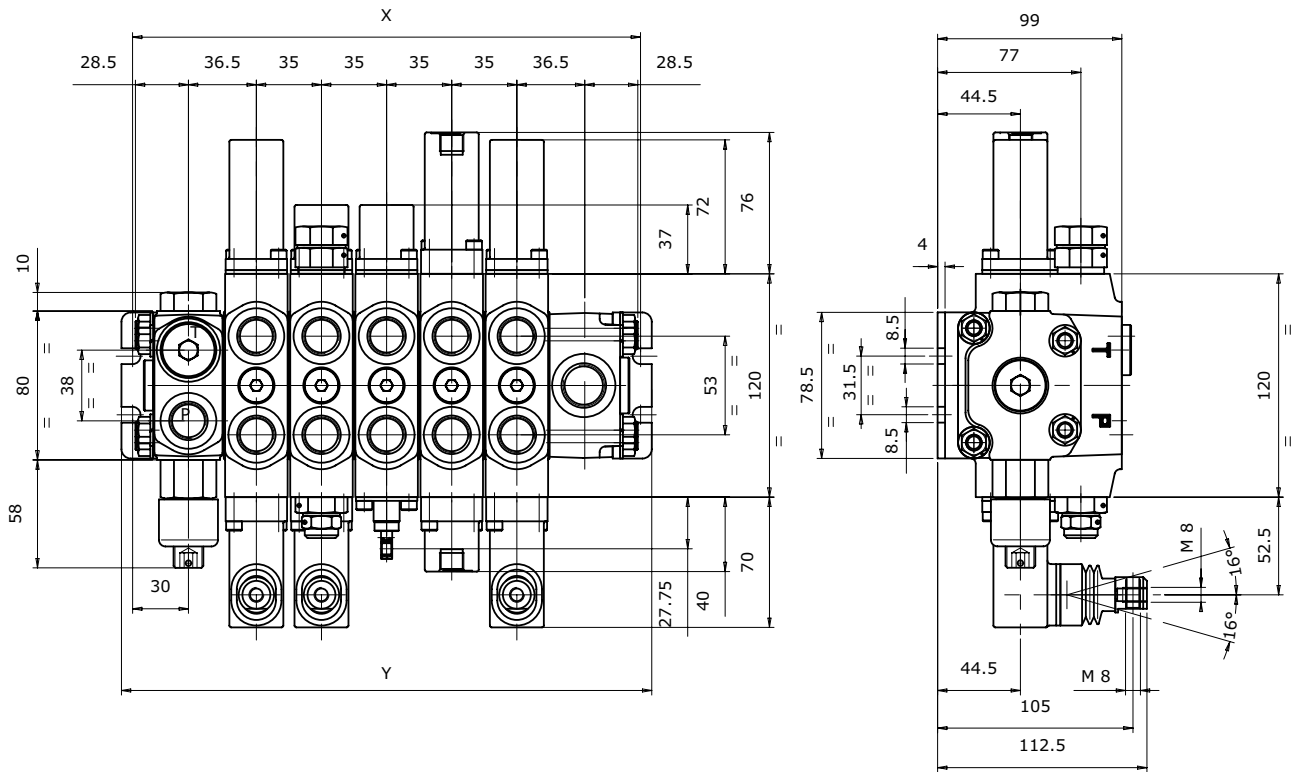

type	/1	/2	/3	/4	/5	/6	/7	/8	/9	/10	/11	/12
<b>X (mm)</b>	133	168	203	238	273	308	343	378	413	448	483	518
<b>Y (mm)</b>	145	180	215	250	285	320	355	390	425	460	495	530
<b>Weights (kg)</b>	6	8.5	11	13.5	16	18.5	21	23.5	26	28.5	31	33.5



**TYPICAL CURVES**

Indicated values have been tested with standard sectional valve and W001A spool.

**Pressure drop (P - T)**

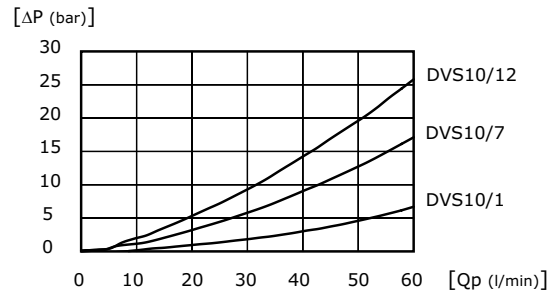
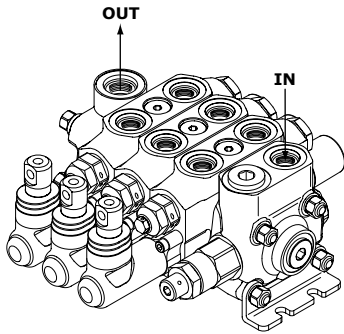

**Pressure drop (P - A/B)**

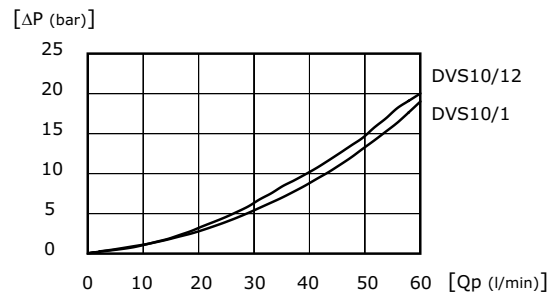
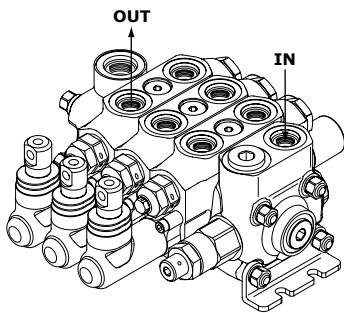

**Pressure drop (A/B - T)**

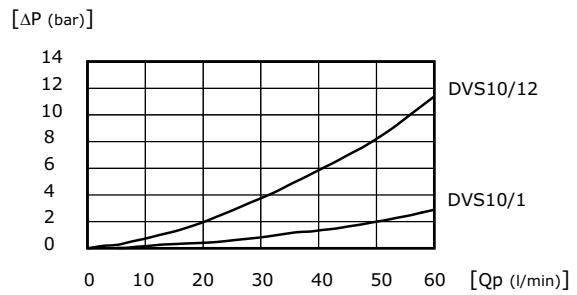
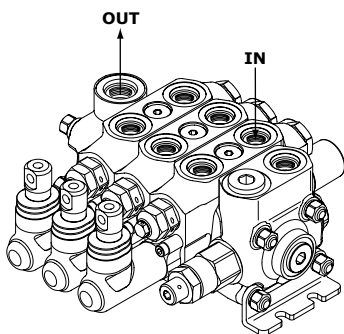



**TYPICAL CURVES**

Indicated values have been tested with standard sectional valve and W001A spool.

**Direct relief valve curve**

Setting ranges	
type	pressure (bar)
A	30 - 110
B	111 - 220
C	221 - 350

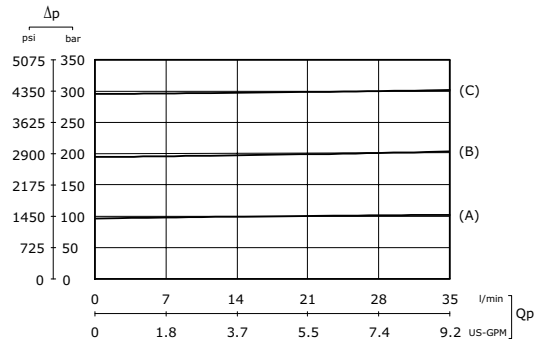

**Antishock valve curve**

type	Setting ranges	
	at full flow	at min. flow
A	20 - 100	10-A / 80-A
B	101 - 220	81-A / 180-A
C	221 - 350	181-A / 350-A

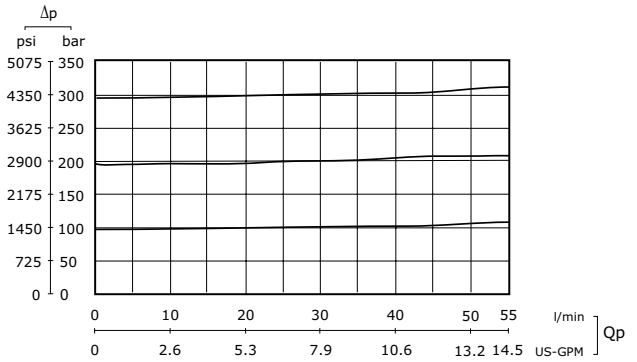

**Combined valve curve**

type	Setting ranges	
	at full flow	at min. flow
A	20 - 60	10-A / 40-A
B	61 - 100	41-A / 80-A
C	101 - 220	81-A / 180-A
D	221 - 350	181-A / 350-A

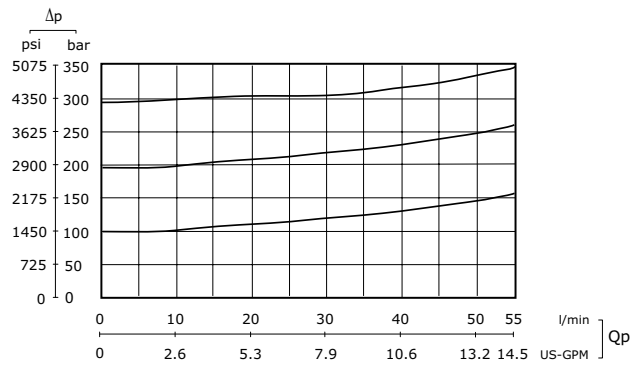



**INLET SECTION**

Order example

<b>IR</b>	<b>001</b>	<b>150</b>	<b>A U03</b>
-----------	------------	------------	--------------

- 1. IR** inlet side classification \_\_\_\_\_
- 001** valve arrangement \_\_\_\_\_
- 150** setting (bar) \_\_\_\_\_
- 2. A U03** inlet position and available thread type \_\_\_\_\_

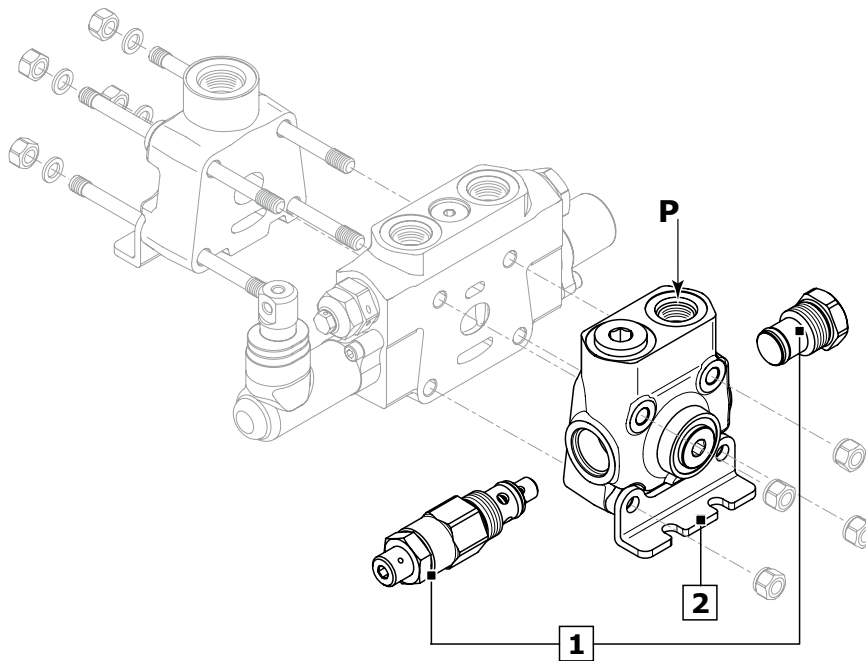

Rif.	Code	Description	Page
-	<b>IR</b>	Sectional valve with right inlet section	<b>11</b>
-	<b>IL</b>	Sectional valve with left inlet section	<b>11</b>
<b>1</b>	<b>001</b> <b>019</b>	Direct acting pressure relief valve without valves	<b>11</b>
<b>2</b>	<b>A G03</b> <b>C G03</b> <b>E G03</b> <b>A U03</b> <b>C U03</b> <b>E U03</b>	Upper inlet (thread G 3/8) Central side inlet (thread G 3/8) Upper inlet (inlet-outlet) (thread G 3/8) Upper inlet (thread 3/4" - 16 UNF) Central side inlet (thread 3/4" - 16 UNF) Upper inlet (inlet-outlet) (thread 3/4" - 16 UNF)	<b>12</b>

**NOTE:** when ordering a relief valve it is necessary to specify factory setting (example 150).



**Inlet side classifications**

	Sectional valve with <b>right inlet</b> section	Sectional valve with <b>right inlet</b> section
<b>IR</b>	 	 

**Valve identification**

type	schema	layout	description	type	schema	layout	description
<b>1</b>			Direct acting pressure relief valve	<b>3</b>			Relief valve plugged

**Valve arrangement**

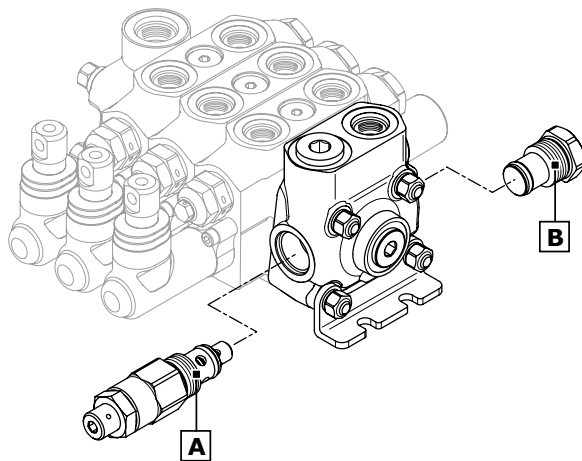

**Combination valve example: 001 = 1A - 3B**

- 001** Combination valve
- 1A** Pressure relief valve in port A
- 3B** Relief valve plugged in port B

**The code identifies:**  
with a number, the type of valve; with a letter its position on the inlet section.

- (A) = spool action side
- (B) = spool return action side

**NOTE:** when ordering a main relief valve it is necessary to specify setting

		port B	
		<b>1</b>	<b>3</b>
port A		<b>1</b>	<b>001</b>
		<b>3</b>	<b>017</b>

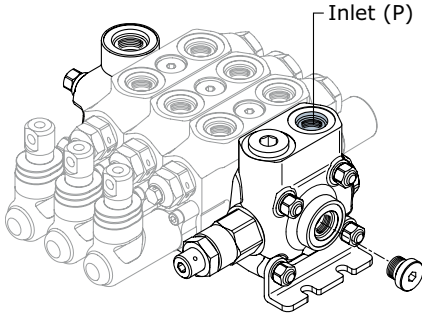
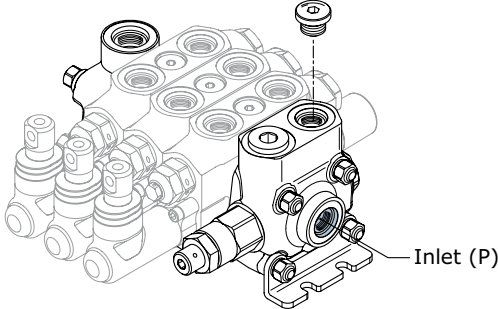
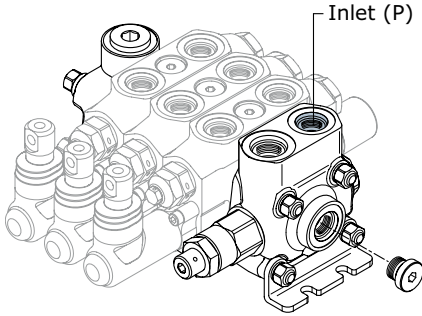

**Inlet position and available thread type**

<b>Inlet combination and thread available</b>		
<b>A G04</b>		Upper inlet (P)
<b>A U03</b>		
<b>A U04</b>		
<b>C G04</b>		Central side inlet (P)
<b>C U03</b>		
<b>C U04</b>		
<b>E G04</b>		Upper inlet (inlet - outlet)
<b>E U03</b>		
<b>E U04</b>		

**NOTE: code "E" on inlet section obliges to choice "E", "W" or "Y" on outlet section.**



**WORKING SECTION**

Order example:

	W001A	H001	F001A	RP U03	01 PA 100	05 PB
1. <b>W001A</b>	spool type					
2. <b>H001</b>	spool actuation type					
3. <b>F001A</b>	spool return action type					
4. <b>RP U03</b>	section and thread type					
5. <b>01 PA 100</b>	auxiliary valve (port A - handle side)					
6. <b>05 PB</b>	auxiliary valve (port B - cap side)					

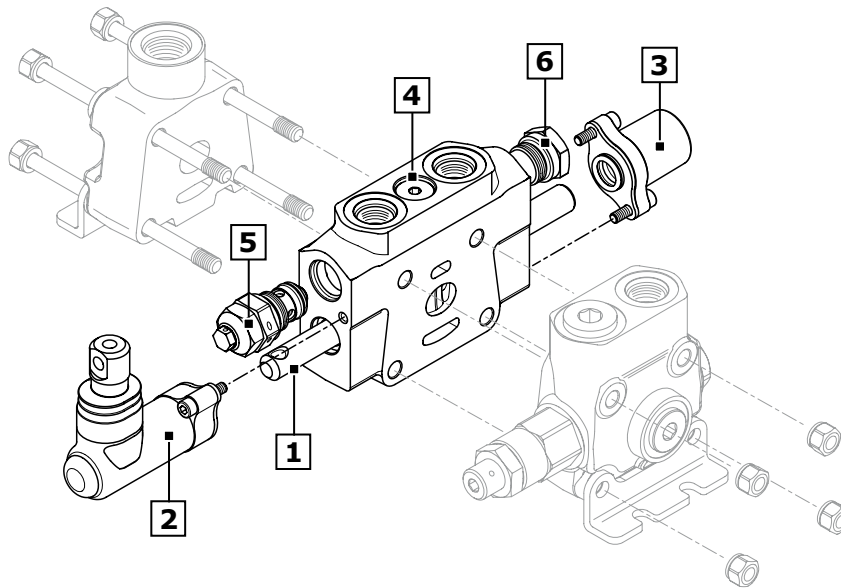

Rif.	Code	Description	Page
1	<b>W001</b>	3 positions double-acting	14
	<b>W002</b>	3 positions double-acting A-B to tank	
2	<b>H001</b>	Protected lever	16
	<b>H005</b>	hydraulic actuation	
3	<b>F001A</b>	3 positions spring-centred spool (spring A)	17
	<b>F002A</b>	3 positions spring-centred spool detent in A and B (spring A)	
4	<b>RP G03</b>	Parallel circuit (G 3/8)	22
	<b>RP U03</b>	Parallel circuit (3/4"-16 UNF)	
	<b>RT G03</b>	Parallel-Tandem circuit (G 3/8)	
	<b>RT U03</b>	Parallel-Tandem circuit (3/4"-16 UNF)	
5	<b>01 PA 100</b>	Antishock valve (port A)	23
	<b>05 PA</b>	Prearrangement for auxiliary valve (port A)	
6	<b>01 PB 100</b>	Antishock valve (port B)	23
	<b>05 PB</b>	Prearrangement for auxiliary valve (port B)	

**NOTE:** (\*) Leave out the spool return action code when choosing H005.  
 Sections designed to house auxiliary valve option require double choice on work ports A and B.  
 Always indicate setting value when using antishock and combined valve: **01 PA (100) - 03 PA (120)**



Spool identification

order example of spool: **W001 A J10**

**W001** spool schema 3 positions double-acting

**A** spool type standard spool

**J10** restricted service ports restriction on diameter (0,10 mm in A and B)

**W001** 3 positions double-acting

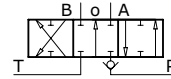

**W002** 3 positions double-acting A and B to tank

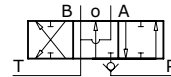

**W003** 3 positions double-acting A to tank B blocked

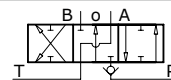

**W004** 3 positions double-acting A blocked B to tank

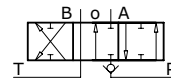

**W005** 3 positions single - acting on A

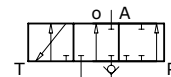

**W006** 3 positions single - acting on B

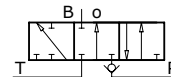

**W012** 4 positions double-acting with float in the 4<sup>th</sup> position

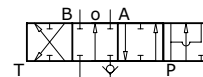

**W015** 3 positions double-acting series

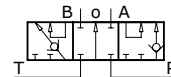

**W020** 4 positions double-acting with float in the 4<sup>th</sup> position

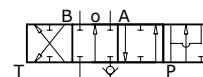

**NOTE:**

There are two types of spools available with floating position:

- **FLOAT IN SPOOL (code W012)**
- **FLOAT OUT SPOOL (code W020)**

Is always necessary to specify the type of spools installed in the float function.

Further information are available in the "spool return action" section.

For spool W012 is necessary to apply detent kit number F005, or F017; for spool W020 is necessary to apply detent kit number F015, or F016. W012, W020 spools need a special machining on the valve body.

W015 spool need RS type body.



spools with restricted service ports				
code	circuit	restriction on diameter (mm)	section (mm <sup>2</sup> )	hydraulic schema
<b>J10</b>	A-B IN T	0,10	2,66	
<b>K10</b>	A IN T	0,10	2,66	
<b>Y10</b>	B IN T	0,10	2,66	

spool type available (inlet flow)			
CODE	Q = 45 l/min	Q = 30 l/min	Q = 15 l/min
	A	B	E
<b>W001</b>	W001A	W001B	W001C
<b>W002</b>	W002A	W002B	W002C
<b>W003</b>	W003A	W003B	W003C
<b>W004</b>	W004A	W004B	W004C
<b>W005</b>	W005A	W005B	
<b>W006</b>	W006A	W006B	
<b>W012</b>	W012A	W012B	
<b>W015</b>	W015A		
<b>W020</b>	W020A	W020B	

Different spools are available on request.  
 Please contact our Sales department for more information.



Spool actuation classification for manual control

code	description	dimensions	configuration
H001	Protected lever		
H002	Protected lever rotated 180°		
H004	Control without lever (tang)		
H030	Control without lever (clevis)		

Spool actuation classification for Hydraulic control

code	description	dimensions	configuration
H005	Hydraulic actuation with side ports  BSP ports = G 1/4 UNF ports = 9/16-18 UNF		

Hydraulic pilot control curve

The diagram shows the spool stroke as a function of the pressure operating.

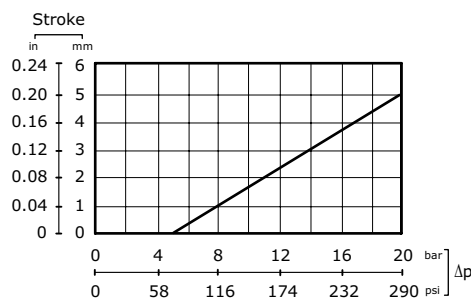



**Spool return action classification - Springs load values**

Spool return kits have three different spring types; following the codes depending on spring loads.

Spring type			
Code	A (standard spring)	B (soft spring)	C (heavy spring)
<b>Preloading</b>	98 N	71 N	120 N
<b>End of stroke</b>	125 N	102 N	150 N
Spool return action identification example			
<b>Code</b>	<b>F001A</b>	<b>F001B</b>	<b>F001C</b>

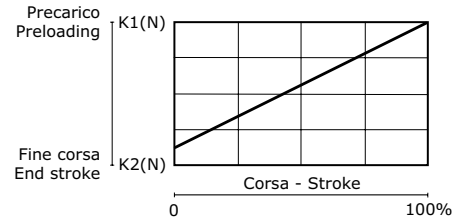

**Spool return action classification**

code	description	schema	dimensions	configuration
<b>F001A</b> <b>F001B</b> <b>F001C</b>	3 positions spring-centred spool			
<b>F002A</b>	3 positions spring-centred spool detent in A and B			
<b>F003A</b>	3 positions spring-centred spool detent in A			
<b>F004A</b>	3 positions spring-centred spool detent in B			



Detent kit classification

code	description	schema	dimensions	configuration
<b>F005A</b> <b>F005B</b> <b>F005C</b>	4 positions spring-centred spool detent in 4 <sup>th</sup> pos. (FLOAT IN) (only for W012 spool)			
<b>F017A</b> <b>F017B</b> <b>F017C</b>	4 positions spring-centred spool with feel in 4 <sup>th</sup> pos. (FLOAT IN) (only for W012 spool)			
<b>F015A</b> <b>F015B</b> <b>F015C</b>	4 positions spring-centred spool detent in 4 <sup>th</sup> pos. (FLOAT OUT) (only for W020 spool)			
<b>F016A</b> <b>F016B</b> <b>F016C</b>	4 positions spring-centred spool with feel in 4 <sup>th</sup> pos. (FLOAT OUT) (only for W020 spool)			



**Electrohydraulic control specifications**

Operating temperature range	-20°C / +80°C
Max inlet pressure	350 bar
Reduced pressure	16 bar
Back pressure on (T)	3 bar
Filtering degree	25 μ assoluti
Raccommended pilot pipe size	Ø 6 mm - G 1/4

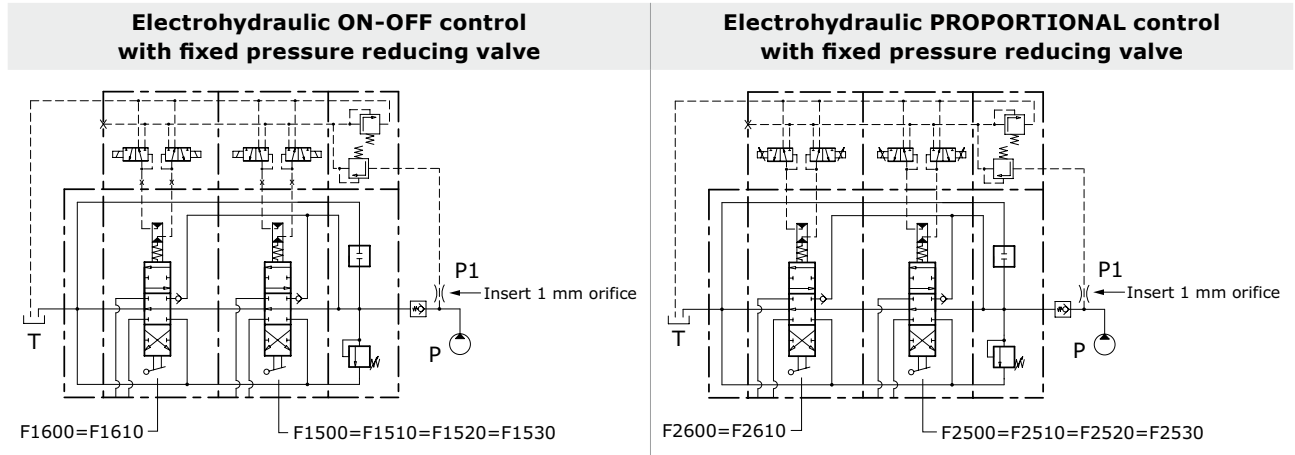

Proportional control kit, mechanically retrooperated, allows the maximum precision of positioning, limiting the hysteresis. The control is operated with PWM control of the current. PWM frequency suggest: 60-80 Hz

Nominal voltage (V)	regulation currents		
	Resistance R <sub>20</sub> (Ohm)	Current min (A)	Current max (A)
12 vdc	3,7	0,9	1,7
24 vdc	15,5	0,45	0,85

**Electrohydraulic control classification**

code	description	dimensions	configuration
<b>F1600</b>	3 positions electrohydraulic control ON - OFF 12 Vdc		
<b>F1610</b>	3 positions electrohydraulic control ON - OFF 24 Vdc		
<b>F2600</b>	3 positions electrohydraulic control PROPORTIONAL 12 Vdc		
<b>F2610</b>	3 positions electrohydraulic control PROPORTIONAL 24 Vdc		

Electrohydraulic ON-OFF control is stackable with electrohydraulic PROPORTIONAL control (F2600 = F2610). Control kit already includes orifice to make spool displacement more gradual.

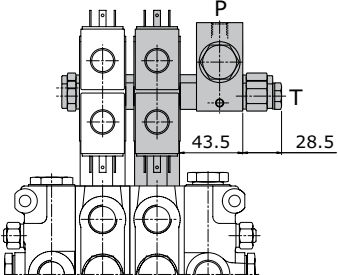
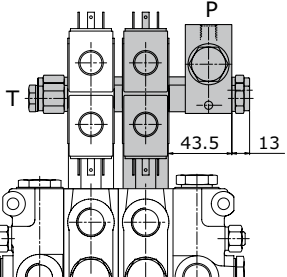

**Electrohydraulic control with fixed pressure reducing valve classification**

code	description	configuration
<b>F1500</b>	Electrohydraulic control ON - OFF (fixed pressure reducing valve) P - T inlet side (12 vdc)	 <p>Port BSP (P - T) = G 1/4 Port UNF (P - T) = 9/16"18 UNF</p>
<b>F1510</b>	Electrohydraulic control ON - OFF (fixed pressure reducing valve) P - T inlet side (24 vdc)	
<b>F2500</b>	Electrohydraulic control PROPORTIONAL (fixed pressure reducing valve) P - T inlet side (12 vdc)	
<b>F2510</b>	Electrohydraulic control PROPORTIONAL (fixed pressure reducing valve) P - T inlet side (24 vdc)	
<b>F1520</b>	Electrohydraulic control ON - OFF (fixed pressure reducing valve) P inlet - T outlet (12 vdc)	 <p>Port BSP (P - T) = G 1/4 Port UNF (P - T) = 9/16"18 UNF</p>
<b>F1530</b>	Electrohydraulic control ON - OFF (fixed pressure reducing valve) P inlet - T outlet (24 vdc)	
<b>F2520</b>	Electrohydraulic control PROPORTIONAL (fixed pressure reducing valve) P inlet - T outlet (12 vdc)	
<b>F2530</b>	Electrohydraulic control PROPORTIONAL (fixed pressure reducing valve) P inlet - T outlet (24 vdc)	

**Control tie rod assembly**

The length of the control tie rod, will change depending on the section numbers; in this way it will be easy to install in the right way the sections and avoid any misassembly. Each kit is composed by 2 tie rods, 2 plugs, 2 connection ports and spacers according to the section number.

**NOTE:** the control tie rod kit has always to be ordered separately.  
Reducing valve, combined with electrohydraulic control kit has to be calculated as a normal working section.

**ORDER EXAMPLE:**

Complete valves with 3 sections F1600 requires a complete tie-rod kit /3.  
Complete valves with 2 sections F1600 and 1 section with F1500 (reducing valve) requires a complete tie-rod kit /4.

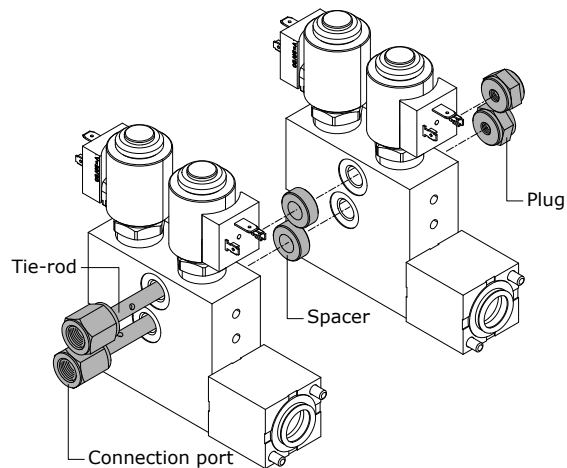

**Order code fixed pressure reducing valve:**

- 915000303** = reducing valve for BSP ports
- 915000312** = reducing valve for UNF ports

**Order code for control tie rod (BSP):**

- 320103001** = control tie rod /1
- 320103002** = control tie rod /2
- 320103003** = control tie rod /3
- 320103004** = control tie rod /4
- 320103005** = control tie rod /5
- 320103006** = control tie rod /6
- 320103007** = control tie rod /7
- 320103008** = control tie rod /8
- 320103009** = control tie rod /9

**Order code for control tie rod (UNF):**

- 320103026** = control tie rod /1
- 320103027** = control tie rod /2
- 320103028** = control tie rod /3
- 320103029** = control tie rod /4
- 320103030** = control tie rod /5
- 320103031** = control tie rod /6
- 320103032** = control tie rod /7
- 320103033** = control tie rod /8
- 320103034** = control tie rod /9



Compatibility table

SPOOL ACTION TYPE	SPOOL TYPE																				
	W001A	W001B	W001C	W002A	W002B	W002C	W003A	W003B	W003C	W004A	W004B	W004C	W005A	W005B	W006A	W006B	W012A	W012B	W015A	W020A	W020B
H001	•	•	•	•	•	•	•	•	•	•	•	•	•	•	•	•	•	•	•	•	•
H002	•	•	•	•	•	•	•	•	•	•	•	•	•	•	•	•	•	•	•	•	•
H004	•	•	•	•	•	•	•	•	•	•	•	•	•	•	•	•	•	•	•	•	•
H005	•	•	•	•	•	•	•	•	•	•	•	•	•	•	•	•	•	•	•	•	•
H030	•	•	•	•	•	•	•	•	•	•	•	•	•	•	•	•	•	•	•	•	•
SPOOL RETURN ACTION TYPE	SPOOL TYPE																				
	W001A	W001B	W001C	W002A	W002B	W002C	W003A	W003B	W003C	W004A	W004B	W004C	W005A	W005B	W006A	W006B	W012A	W012B	W015A	W020A	W020B
F001	•	•	•	•	•	•	•	•	•	•	•	•	•	•	•	•			•		
F002	•	•	•	•	•	•	•	•	•	•	•	•	•	•	•	•			•		
F003	•	•	•	•	•	•	•	•	•	•	•	•	•	•	•	•			•		
F004	•	•	•	•	•	•	•	•	•	•	•	•	•	•	•	•			•		
F005																	•	•			
F015																				•	•
F016																				•	•
F017																	•	•			



Work section identification

working section type

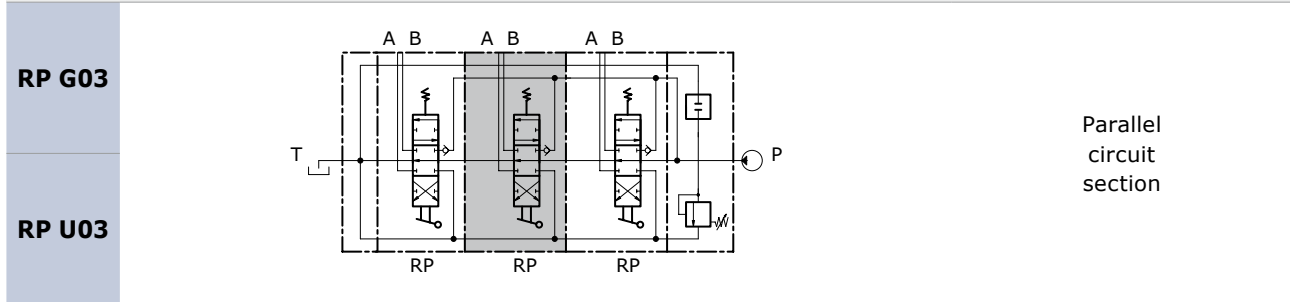

When the spool is operated it intercepts the by-pass gallery by diverting the flow of oil to service port A or B. If two or more spools are actuated at the same time, the oil will power the service port that has the lower load; by throttling the spools, the flow of oil can be divided between two or more service ports.

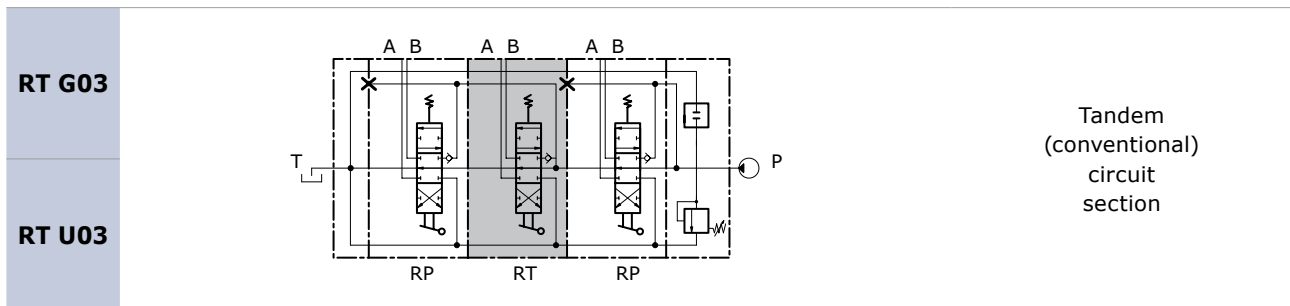

When the spool is operated it intercepts the switch gallery by diverting the flow of oil to service port A or B. The Tandem circuit is powered by the switch gallery thus permitting the use of just one work section at a time. The section downstream from the tandem section that has been actuated does not operate, the upstream section has priority.

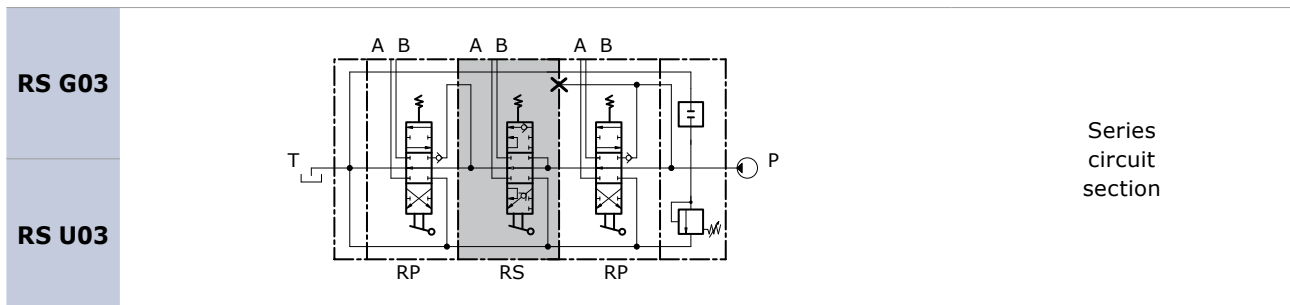

When the spool is operated it intercepts the switch gallery by diverting the flow of oil to service port A or B. The oil that flows back from the actuator is carried to the switch gallery thus making it available to the service ports downstream from the series section. The pressure drop downstream is added to the pressure drop of the section itself.



**Auxiliary valve identification**

code	description	schema	configuration	setting range (bar)			
				type	at full flow	type	at min. flow
01PA	Antishock valve (port A)			A	20 / 100	A	10-A / 80-A
				B	101 / 220	B	81-A / 180-A
				C	221 / 350	C	181-A / 350-A
02PA	Anticavitation valve (port A)						
03PA	Combined valve (port A)			A	20 / 60	A	10-A / 40-A
				B	61 / 100	B	41-A / 80-A
				C	101 / 220	C	81-A / 180-A
				D	221 / 350	D	181-A / 350-A
05PA	Prearrangement for auxiliary valve (port A)						

code	description	schema	configuration	setting range (bar)			
				type	at full flow	type	at min. flow
01PB	Antishock valve (port A)			A	20 / 100	A	10-A / 80-A
				B	101 / 220	B	81-A / 180-A
				C	221 / 350	C	181-A / 350-A
02PB	Anticavitation valve (port A)						
03PB	Combined valve (port A)			A	20 / 60	A	10-A / 40-A
				B	61 / 100	B	41-A / 80-A
				C	101 / 220	C	81-A / 180-A
				D	221 / 350	D	181-A / 350-A
05PB	Prearrangement for auxiliary valve (port A)						

**Auxiliary valve - Setting range**

Sections designed to house auxiliary valve option require double choice on work ports A and B.

Always indicate setting value when using antishock valve and combined valve:

**01PA (120) = setting at full flow**

**01PA (120-A) = setting at min. flow**



**OUTLET SECTION (VERSION 1 OUTLET)**

**Order example**

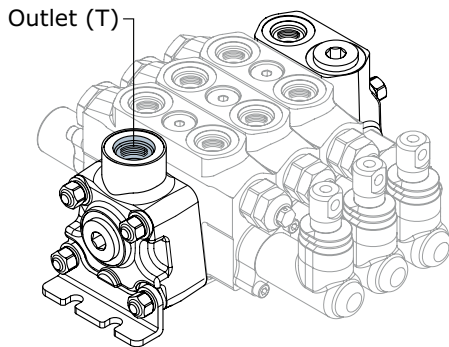

**TJ** | **A U04**

1. **TJ** outlet section type
2. **A U04** outlet position and available thread type

Rif.	Code	Description	Page
1	<b>TJ</b>	Outlet section with single return (T) right-side inlet (P)	
	<b>TK</b>	Outlet section with single return (T) left-side inlet (P)	
2	<b>A G04</b>	Upper outlet (thread G 1/2)	25
	<b>C G04</b>	Central outlet (thread G 1/2)	
	<b>A U04</b>	Upper outlet (thread 7/8" - 14 UNF)	
	<b>C U04</b>	Central outlet (thread 7/8" - 14 UNF)	

**OUTLET SECTION (HPCO VERSION OUTLET)**

**Order example - HPCO version Outlet**

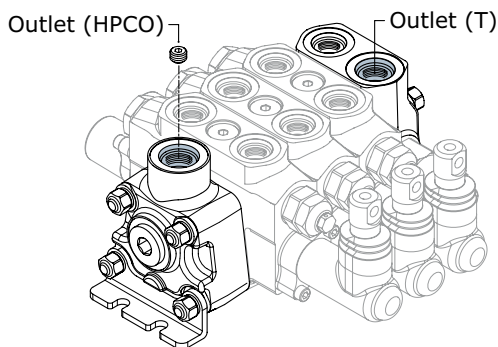

**TM** | **W U04**

1. **TM** outlet section type
2. **W U04** outlet position and available thread type

Rif.	Code	Description	Page
1	<b>TM</b>	Outlet section with two return (T-HPCO) right-side inlet (P)	
	<b>TN</b>	Outlet section with two return (T-HPCO) left-side inlet (P)	
2	<b>W G04</b>	HPCO Upper inlet - outlet T (tank) upper outlet section (thread G 1/2)	26
	<b>W U04</b>	HPCO Upper inlet - outlet T (tank) upper outlet section (thread 7/8" - 14 UNF)	



Outlet with single tank classification

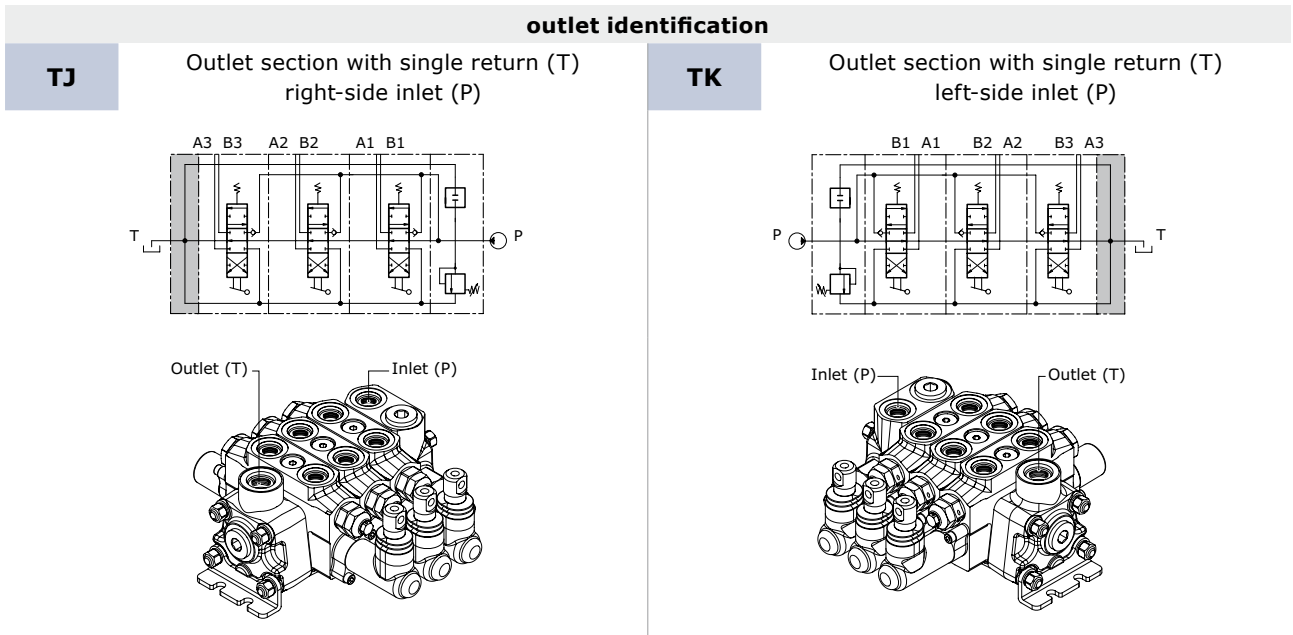

outlet combination and thread available	
<b>A G04</b>	<p style="text-align: right;">Upper outlet (thread G 1/2)</p>
<b>A U04</b>	<p style="text-align: right;">Upper outlet (thread 3/4" - 16 UNF)</p>
<b>C G04</b>	<p style="text-align: right;">Central side outlet (thread G 1/2)</p>
<b>C U04</b>	<p style="text-align: right;">Central side outlet (thread 7/8" - 14 UNF)</p>
<b>E G04</b>	<p style="text-align: right;">Upper outlet (inlet - outlet) (thread G 1/2)</p>
<b>E U04</b>	<p style="text-align: right;">Upper outlet (inlet - outlet) (thread 7/8" - 14 UNF)</p>

**NOTE: code "E" on outlet section obliges to choice E on inlet section.**



Outlet with two tanks classification

outlet identification

TM

Outlet section with two return (T-HPCO) right-side inlet (P)

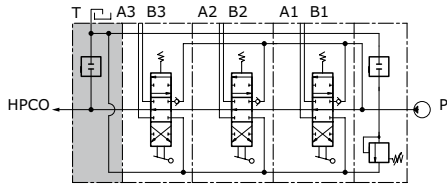

Outlet (HPCO) Inlet (P) Outlet (T)

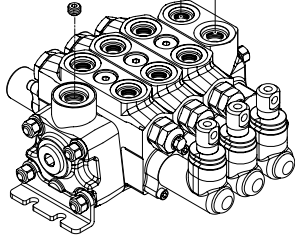

TN

Outlet section with two return (T-HPCO) left-side inlet (P)

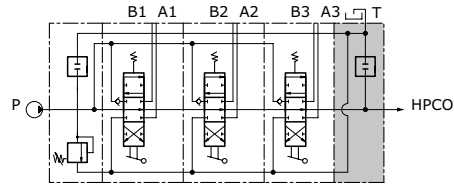

Inlet (P) Outlet (T) Outlet (HPCO)

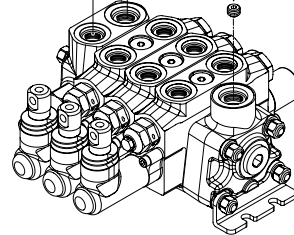

outlet combination and thread available

W G04

Outlet (HPCO) Inlet (P) Outlet (T)

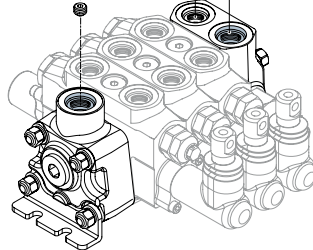

HPCO Upper inlet - outlet T (tank) upper outlet section (thread G 1/2)

W U04

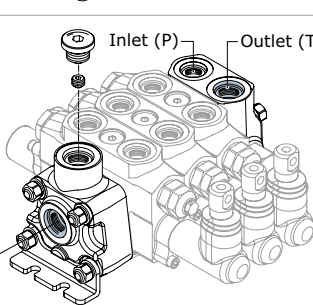

HPCO Upper inlet - outlet T (tank) upper outlet section (thread 7/8" - 14 UNF)

Y G04

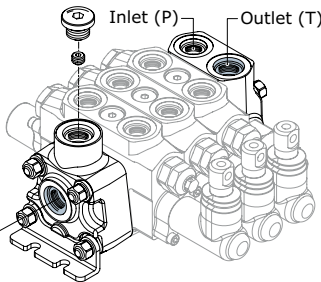

HPCO Upper inlet - outlet T (tank) central outlet section (thread G 1/2)

Y U04

Outlet (HPCO)

HPCO Upper inlet - outlet T (tank) central outlet section (thread 7/8" - 14 UNF)

NOTE: code "W" or "Y" on outlet section obliges to choice E on inlet section.



**Carry-over connection (HPCO)**

This option, available on all DVS10, allows the sectional valve to feed a second valve, by extending the free flow channel. In this configuration, the valve need a separated port for connection to tank.

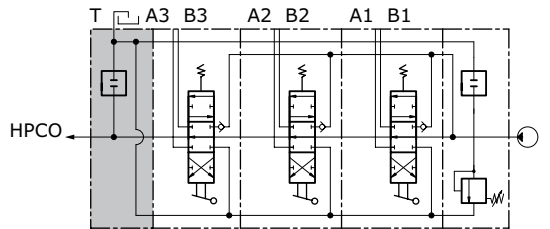

It is possible to transform sectional valve from standard to HPCO version just by ordering the appropriate conic plug:

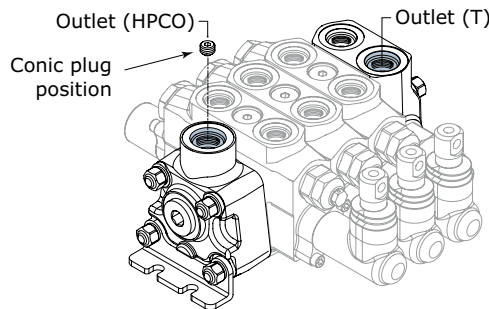

code (HPCO Plug identification)	description	q.ty
413010203	conic plug G 1/4 x 13	1

**NOTE: HPCO option needs "E-G04", "E-U03" or "E-U04" inlet arrangement only.**



DVS10 SPARE PARTS LIST

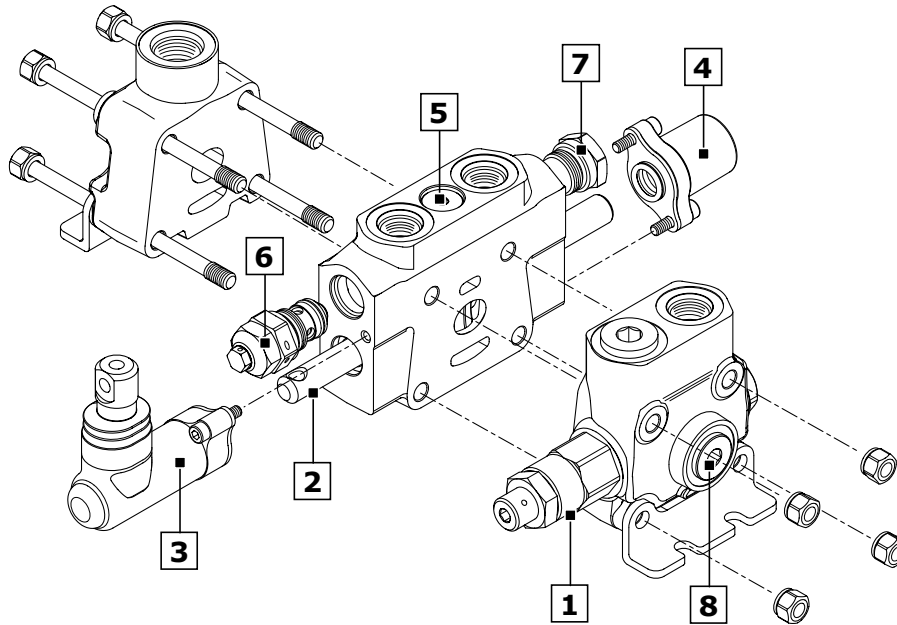

Ref.	Description	Order code	Q.ty	Code	Note
<b>1</b>	Direct acting pressure relief valve (*)	<b>84642</b>	1	-	Setting: 100 bar
		<b>29005</b>			Setting: 200 bar
		<b>38339</b>			Setting: 300 bar
	Relief valve plugged	<b>430146001</b>	1		
<b>2</b>	3 positions double-acting spool	<b>421266029</b>	1	<b>W001A</b>	
		<b>421266028</b>		<b>W001B</b>	
		<b>421266027</b>		<b>W001C</b>	
	3 positions double-acting A and B to tank spool	<b>421266032</b>	1	<b>W002A</b>	
		<b>421266031</b>		<b>W002B</b>	
		<b>421266030</b>		<b>W002C</b>	
	3 positions single-acting on A	<b>421266041</b>	1	<b>W005A</b>	
	3 positions single-acting on B	<b>421266044</b>	1	<b>W006A</b>	
4 positions double-acting with float in the 4 <sup>th</sup> pos.	<b>421266053</b>	1	<b>W012A</b>		
		<b>421266056</b>		<b>W020A</b>	
<b>3</b>	Protected lever	<b>320366001</b>	1	<b>H001 = H002</b>	
	Control without lever	<b>320366003</b>	1	<b>H004 = H030</b>	
	Hydraulic actuation with side ports	<b>320566001</b>	1	<b>H005</b>	
	3 position spring centred spool	<b>320766002</b>	1	<b>F001A</b>	
		<b>320700003</b>	1	<b>F001B</b>	
		<b>320766001</b>	1	<b>F001C</b>	
	Detent in A and B	<b>320866012</b>	1	<b>F002A</b>	
	Detent in A	<b>320866018</b>	1	<b>F003A</b>	
	Detent in B	<b>320866020</b>	1	<b>F004A</b>	
	Pneumatic control ON-OFF	<b>321166001</b>	1	<b>F020A=F021A</b>	BSP ports
		<b>321166002</b>		<b>F135A=F136A</b>	NPT ports
<b>4</b>	Electrohydraulic ON-OFF (12 vdc)	<b>321466005</b>	1	<b>F1600</b>	
	Electrohydraulic ON-OFF (24 vdc)	<b>321466006</b>	1	<b>F1610</b>	
	Electrohydraulic Proportional (12 vdc)	<b>322066001</b>	1	<b>F2600</b>	
	Electrohydraulic Proportional (24 vdc)	<b>322066002</b>	1	<b>F2610</b>	



Ref.	Description	Order code	Q.ty	Code	Note
<b>4</b>	Electrohydraulic ON-OFF (12 vdc) with reducing valve	<b>321466007</b>	1	<b>F1500=F1520</b>	
	Electrohydraulic ON-OFF (24 vdc) with reducing valve	<b>321466008</b>	1	<b>F1510=F1530</b>	
	Electrohydraulic Proportional (12 vdc) with reducing valve	<b>322066003</b>	1	<b>F2500=F2520</b>	BSP ports
	Electrohydraulic Proportional (24 vdc) with reducing valve	<b>322066004</b>	1	<b>F2510=F2530</b>	
	Electrohydraulic ON-OFF (12 vdc) with reducing valve	<b>321466011</b>	1	<b>F1500=F1520</b>	
	Electrohydraulic ON-OFF (24 vdc) with reducing valve	<b>321466012</b>	1	<b>F1510=F1530</b>	
	Electrohydraulic Proportional (12 vdc) with reducing valve	<b>322066006</b>	1	<b>F2500=F2520</b>	UNF ports
	Electrohydraulic Proportional (24 vdc) with reducing valve	<b>322066007</b>	1	<b>F2510=F2530</b>	
<b>5</b>	Check valve on the work section	<b>320266001</b>	1	-	
<b>6</b>		<b>4044</b>			Setting: 100 bar
	Antishock valve on port A	<b>6891</b>		<b>01 PA</b>	Setting: 200 bar
		<b>9778</b>			Setting: 300 bar
	Anticavitation valve on port A	<b>915083001</b>	1	<b>02 PA</b>	
		<b>23504</b>			Setting: 100 bar
	Combined valve on port A	<b>14779</b>		<b>03 PA</b>	Setting: 200 bar
	<b>38346</b>			Setting: 300 bar	
	Prearrangement for auxiliary valve on port A	<b>430430001</b>		<b>05 PB</b>	
<b>7</b>		<b>4044</b>			Setting: 100 bar
	Antishock valve on port B	<b>6891</b>		<b>01 PB</b>	Setting: 200 bar
		<b>9778</b>			Setting: 300 bar
	Anticavitation valve on port B	<b>915083001</b>	1	<b>02 PB</b>	
		<b>23504</b>			Setting: 100 bar
	Combined valve on port A	<b>14779</b>		<b>03 PB</b>	Setting: 200 bar
	<b>38346</b>			Setting: 300 bar	
	Prearrangement for auxiliary valve on port B	<b>430430001</b>		<b>05 PB</b>	
<b>8</b>	Plug kit (G 3/8)	<b>430000018</b>		<b>G03</b>	
	Plug kit (3/4" - 16 UNF)	<b>300066001</b>	1	<b>U03</b>	
	Plug kit (G 1/2)	<b>430000019</b>		<b>G04</b>	
	Plug kit (7/8" - 14 UNF)	<b>300066002</b>		<b>U04</b>	

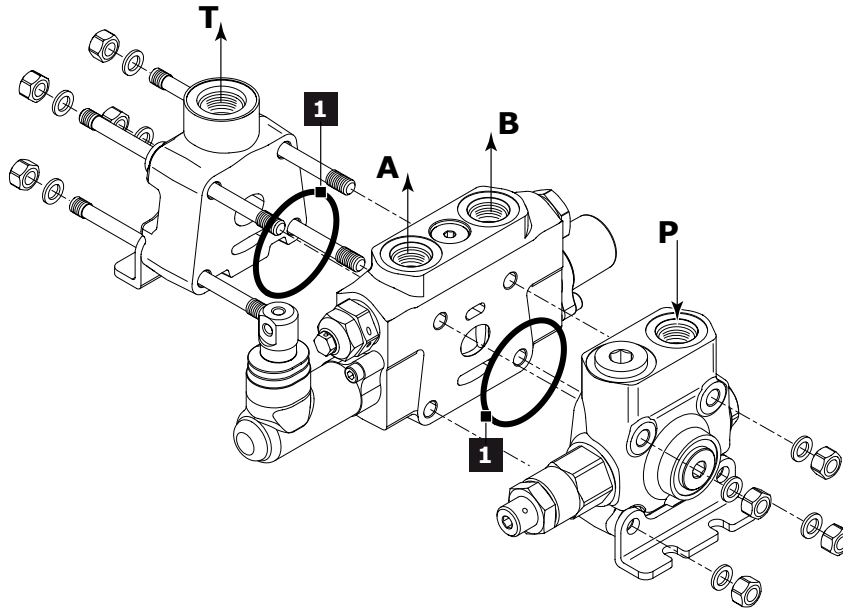

Inlet and work section			
Rif.	Order code	Description	Q.ty
1	412010634	O.R. 70SH 50,47 x 2,62 (2-136)	1



**INSTALLATION**

**Guidelines**

- Mount the control valve securely to a flat surface (recommended 3 point fixing); at the time do not use a hammer to positioning by hitting.
- When handling the control valve, be careful not hold the pilot cover or return spring cap of the spool or accessory valves such as main relief valves and anti-shock relief valves.
- Clean piping materials sufficiently before use.
- Make sure to prevent the port openings from being entered with dust or foreign matters.
- Tighten the port connectors surely with the recommended fastening torques.
- Do not direct the jet of a pressure washing unit directly to the valve.

**Fittings tightening torque (Nm)**

thread type	port P	Port A - B	Port T
<b>BSP (ISO - 228)</b>	<b>G 3/8</b>	<b>G 3/8</b>	<b>G 3/8</b>
with rubber sealing (DIN 3869)	40	40	40
with copper or steel and rubber washer	40	40	40
<b>UN-UNF (ISO - 725)</b>	<b>3/4" - 16 UNF</b>	<b>3/4" - 16 UNF</b>	<b>3/4" - 16 UNF</b>
with O.R.	40	40	40

**General clamping torque**

The following table provides the main tightening torques of the sectional valve DVS10:

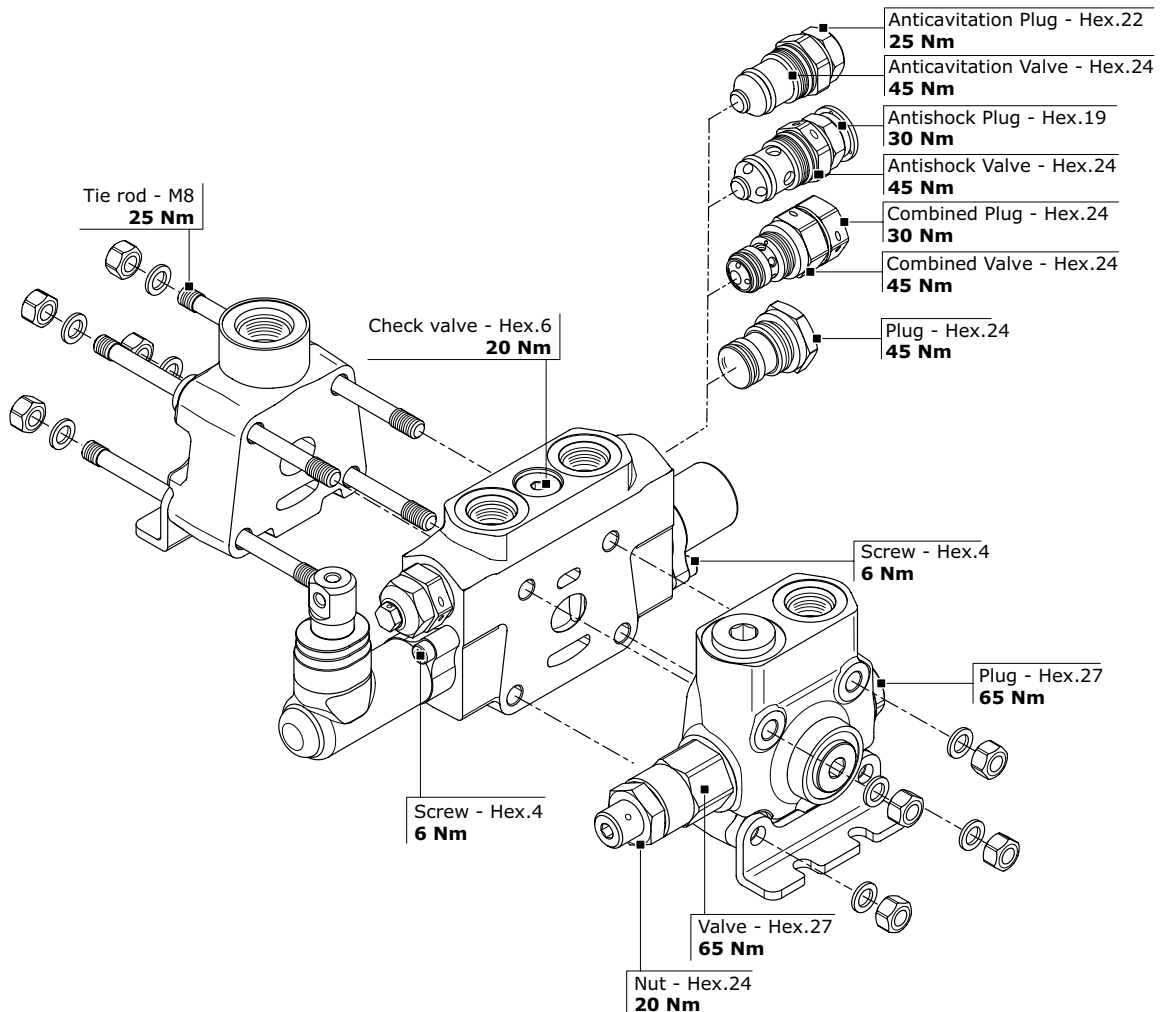



**Dimensions - Thread codes**

The connection ports size is indicated by an ordering code common for all Hydrocontrol products. Following table shows all available connections.

**METRIC THREAD (ISO 9974-1)**

Type	M18x1,5	M22x1,5	M27x2
Code	<b>M01</b>	<b>M02</b>	<b>M03</b>

**BSP THREAD (ISO 1179-1)**

Type	1/4"	3/8"	1/2"	3/4"	1"	1"1/4	1"1/2	2"
Code	<b>G02</b>	<b>G03</b>	<b>G04</b>	<b>G05</b>	<b>G06</b>	<b>G07</b>	<b>G08</b>	<b>G09</b>

**UN / UNF THREAD (ISO 11926-1)**

Type	9/16" 18 UNF SAE6	3/4" 16 UNF SAE8	7/8" 14 UNF SAE10	1"1/16 12 UNF SAE12	1"5/16 12 UNF SAE16	1"5/8 12 UNF SAE20
Code	<b>U02</b>	<b>U03</b>	<b>U04</b>	<b>U05</b>	<b>U06</b>	<b>U07</b>

**Dimensions - SAE Flange codes**

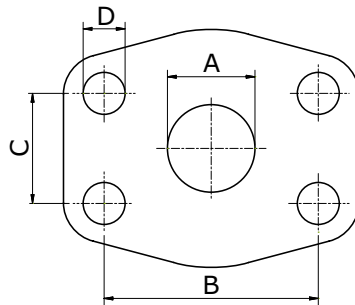

**SAE / 3000 FLANGE (ISO 6162-1)**

Type	3/4" (MA)	3/4" (UNC)	1" (MA)	1" (UNC)	1"1/4 (MA)	1"1/4 (UNC)	1"1/2 (MA)	1"1/2 (UNC)	2" (MA)	2" (UNC)	3" (MA)	3" (UNC)
Code	<b>S03</b>	<b>S04</b>	<b>S05</b>	<b>S06</b>	<b>S07</b>	<b>S08</b>	<b>S09</b>	<b>S10</b>	<b>S11</b>	<b>S12</b>	<b>S15</b>	<b>S16</b>
A	19	19	25	25	32	32	38	38	51	51	76	76
B	47,6	47,6	52,4	52,4	58,7	58,7	69,9	69,9	77,8	77,8	106,4	106,4
C	22,3	22,3	26,2	26,2	30,2	30,2	35,7	35,7	42,9	42,9	61,9	61,9
D	M10	3/8-16	M10	3/8-16	M10	7/16-14	M12	1/2-13	M12	1/2-13	M16	5/8-11

**SAE / 6000 FLANGE (ISO 6162-2)**

Type	3/4" (MA)	3/4" (UNC)	1" (MA)	1" (UNC)	1"1/4 (MA)	1"1/4 (UNC)	1"1/2 (MA)	1"1/2 (UNC)
Code	<b>S33</b>	<b>S34</b>	<b>S35</b>	<b>S36</b>	<b>S37</b>	<b>S38</b>	<b>S39</b>	<b>S40</b>
A	19	19	25	25	32	32	38	38
B	50,8	50,8	57,2	57,2	66,6	66,6	79,3	79,3
C	23,8	23,8	27,8	27,8	31,8	31,8	36,5	36,5
D	M10	3/8-16	M12	7/16-14	M14	1/2-13	M16	5/8-11



## GENERAL CONDITIONS AND PATENTS

### Product identification

All Hydrocontrol products have an identifying plate placed in specific position.

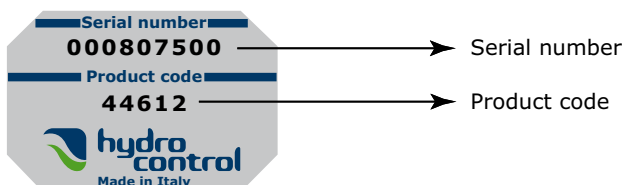

#### Serial number:

It univocally identifies the physical valve: this provides an easy way to find all sales and production details.

#### Product code:

It is a number univocally identifying the configuration and pressure settings of a valve.

### Introduction

These general conditions apply to all general supplies from Hydrocontrol s.p.a., after receiving orders from the Customer. Should commercial terms such as EXW, DDP, etc be mentioned, of course the Incoterms of the International Chamber of Commerce must be referred to, according to the test existing when the general supply conditions are agreed on.

### Management of orders

No Customer's order is binding to Hydrocontrol s.p.a. if Hydrocontrol s.p.a. has not confirmed the order in writing. Hydrocontrol s.p.a. commits to supplying the orders in compliance with the order confirmation that has been issued. Any disagreement with the content of the order confirmation must be communicated in writing to Hydrocontrol s.p.a. within and no later than 5 days from the delivery of the order confirmation. The Customer commits to paying for the goods supplied by Hydrocontrol s.p.a., according to the prices indicated on the order confirmation.

### Payment conditions

The Parties agree on the payment terms at the beginning of the supply. The terms will be indicated on the order confirmation. Should the Customer be late with the payments, Hydrocontrol S.p.a. will be entitled to require the payment of interests on arrears based on the exiting Prime Rate increased by 2%. Should there be any payment delay, Hydrocontrol s.p.a. will be entitled not to process the Customer's purchase order, even if it has already been confirmed.

### Delivery and shipment

The goods are always supplied Ex Works, even when Hydrocontrol s.p.a. agrees with the Customer that the shipment, or a part of it, will be arranged by Hydrocontrol s.p.a. It is agreed that the Customer will bear the risk of goods deterioration or damaging from the moment the goods are handed by Hydrocontrol s.p.a. to the first carrier.

### Product characteristics

Hydrocontrol s.p.a. commits to supplying good quality products, compliant with the technical specifications declared on the technical tables and on the catalogue. Hydrocontrol s.p.a, even without notice, at its own discretion, reserves the right to modify the products as necessary, without these changes altering the main characteristics of the products.

### Claims

Any claims about defects on delivered products (just as an example: claims about the packaging, the number, the quantity or the external product characteristics) will have to be notified to Hydrocontrol s.p.a. in writing, within and no later than 7 days from reception of the goods, otherwise the claims will be considered as null and void. Occult defects (the defects of the goods that cannot be spotted with a careful control of the goods received by the Customer), will have to be notified in writing to Hydrocontrol s.p.a. within 7 days from the discovery of the defect, and anyhow no later than 12 months from the delivery of the goods, otherwise the claim will be considered as null and void. Even in case of claim or objection, the Customer will never be entitled to suspend or delay the payments to Hydrocontrol s.p.a. for the products subject to claim or objection nor for any other supply.

**GENERAL CONDITIONS AND PATENTS****Warranty**

Should the products supplied by Hydrocontrol not be compliant or have the required quality and should this defect be due to Hydrocontrol, Hydrocontrol s.p.a. commits, at its choice, to replace or repair the faulty products, as long as the defect or lack of compliance is notified to Hydrocontrol s.p.a. in writing, as specified at point 6, within and no later than 18 months from product delivery. On the products that have been fixed or replaced in accordance with what specified above, the above-mentioned warranty applies. The 12 month duration starts from the date of repair or replacement. In case of defects, lack of quality or in case of lack of compliance for the supplied products, with the exception of fraud or serious offence, Hydrocontrol s.p.a. only commits to repairing or replacing the faulty products, according to what specified above. This warranty replaces any other Supplier's warranty or liability established by the law. This warranty excludes any other liability contractual or extra-contractual by Hydrocontrol s.p.a. on the products supplied by Hydrocontrol (as a mere example: damage refund, loss of profit, product recall campaign, etc). Hydrocontrol s.p.a. has signed a product civil liability police, with a suitable maximum coverage.

**Ownership retention**

The products supplied by Hydrocontrol s.p.a. will be owned by the latter until Hydrocontrol receives the complete payment for the supplied goods.

**Obligation confidentiality**

Hydrocontrol s.p.a. commits to not disclosing the technical and commercial information it receives from the Customer, unless this information has already been publicly disclosed.

**Patents**

The Customer is not allowed to use the provided Products, or a part of them, their descriptions or drawings protected or not protected by Patent or registered trademark in order to design or make similar products, unless Hydrocontrol s.p.a. previously issues its written authorization. Should Hydrocontrol s.p.a. give its written authorization, all patents, trademarks, registered designs, copyrights and intellectual property rights related or connected to the Products provided by Hydrocontrol s.p.a. will stay Hydrocontrol's property. The Customer commits to respecting the highest confidentiality.

**Applicable law and court of jurisdiction**

Hydrocontrol s.p.a.'s supplies are regulated by these General Supply Conditions and, for anything not defined here, by the Italian law. Any controversy related, generated or connected to the supply of Products by Hydrocontrol s.p.a., where Hydrocontrol s.p.a. is involved, will be exclusively dealt with by the Court of Bologna.

**Walvoil nel mondo - Walvoil worldwide**

**Sede principale, Filiali e Uffici di rappresentanza**  
*Headquarters, Subsidiaries and Representative Offices*

**Walvoil S.p.A. - Sede principale - Headquarters**

Via Adige, 13/D . 42124 Reggio Emilia . Italy  
TEL. +39 0522 932411 . info@walvoil.com -  
www.walvoil.com

**Business Unit Hydrocontrol**

Via Natale Salieri, 6 . 40024  
Castel S. Pietro Terme . Bologna . Italy  
TEL. +39 051 6959411

**Galtech Site**

Via Portella della Ginestra, 10 . 42025 Cavriago  
Zona Industriale Corte Tegge . Reggio Emilia . Italy  
TEL. +39 0522 932411

AUSTRALASIA . *AUSTRALASIA*

**Walvoil Fluid Power Australasia Pty Ltd**

13 Vanessa Way . Delahey VIC 3037 . Melbourne . Australia  
TEL. +61 458 918 750 . australasia@walvoil.com

BRASILE . *BRAZIL*

**Interpump Hydraulics Brasil Ltda - Walvoil Division**

Gilberto de Zorzi, 525 . Forqueta Caxias do Sul (RS)  
TEL. +55 54 3223 2373 . infobrasil@walvoil.com

CANADA . *CANADA*

**Galtech Canada Inc.**

3100, Jacob Jordan . Terrebonne . Qc J6X 4J6 . Canada  
TEL. +1 450 477 1076 Ext:225 . info@galtechcanada.com

CINA . *CHINA*

**Walvoil Fluid Power (Dongguan) Co. Ltd**

1st Floor, the Third Factory Area, Sijia, Shijie Town, Dongguan City, Guangdong province, China.  
TEL. +86 769 81816189-8020 . FAX. +86 769 81816589  
info@walvoil.com.cn

COREA DEL SUD . *SOUTH KOREA*

**Walvoil Fluid Power Korea Ltd.**

80-15, Oseongsandan 1Ro,  
Oseong-Myun, Pyungtaek, Kyungki .  
Korea 451-872 . TEL. +82 31 682 6030  
info@walvoil.co.kr

FRANCIA . *FRANCE*

**Walvoil Fluid Power France**

362 rue de Bretagne . Vritz . 44540 Vallons-de-l'Erdre  
TEL. +33 2 41 94 41 06 . france@walvoil.com

INDIA . *INDIA*

**Walvoil Fluid Power (India) PVT. LTD.**

No. 19, 2nd Cross, 2nd Main, KIADB Industrial Area, Attibele,  
Anekal Taluk, Bangalore - 562107  
TEL. +91 80 0614 24000 . info@walvoil.co.in

U.S.A. . *U.S.A.*

**Walvoil Fluid Power Corp.**

4111 North Garnett Tulsa, OK 74116, USA  
TEL. +1 918 858 7100 . info@walvoilfluidpower.com

**Walvoil Fluid Power Corp. Hydrocontrol Business Unit**

1109, Technology Drive . Red Wing . MN 55066 . U.S.A.  
TEL. +1 651 212 6400 . usa@hydrocontrol-inc.com

2<sup>nd</sup> edition DVS10.01

[www.walvoil.com](http://www.walvoil.com)



D1WHEB10E

