



DVS 14

Sectional directional control valve

TECHNICAL CATALOGUE



A member of



1800-OILSOL
1800-645765

<https://oilsolutions.com.au/>

sales@oilsolutions.com.au

Features

Simple, compact and heavy duty designed sectional valve from 1 to 10 sections for hydraulic systems with fixed or variable displacement pumps.

- Available in left or right inlet configurations.
- Working sections with and without port valves arrangement.
- Flow Unloader configuration available.
- Proportional electrohydraulic controls.
- Optional spool position sensors.

Additional information

This catalogue shows the product in the most standard configurations.
Please, contact Sales Dpt. for more detailed information or special request.

WARNING!

All specifications of this catalogue refer to the standard product at this date.
Walvoil, oriented to a continuous improvement, reserves the right to discontinue, modify or revise the specifications without notice.

WALVOIL IS NOT RESPONSIBLE FOR ANY DAMAGE CAUSED BY AN
INCORRECT USE OF THE PRODUCT.

5th edition November 2021

Content

- Valve general information	
Working conditions	page 4
Standard threads	page 4
Dimensional data	page 5
Performances	page 7
Hydraulic circuit	page 7
Complete section ordering codes	page 8
- Inlet section	
Part ordering codes	page 10
Dimensional data and hydraulic circuit	page 11
Port configurations	page 12
Inlet valves	page 12
- Working section	
Part ordering codes	page 14
Dimensional data and hydraulic circuit	page 17
Spools	page 18
Spool position sensor	page 20
Mechanical controls	page 21
Proportional electrohydraulic controls	page 24
Proportional hydraulic controls	page 28
Port valves	page 29
- Outlet section	
Dimensional data and hydraulic circuit	page 30
- Flow Unloader valve configuration	
Dimensional data and hydraulic circuit	page 34
Part ordering codes	page 36
Inlet section	
Dimensional data and hydraulic circuit	page 38
Inlet valves	page 39
Compensator kit	page 40
Spools	page 40
Outlet section	page 41
- Installation and Maintenance	
Main rules	page 42
Carry-over transformation rules	page 43
Two valves connection	page 44
- Accessories	
Coils and connectors	page 45

Working conditions

This catalogue shows technical specifications and diagrams measured with mineral oil of 46 mm²/s - 46 cSt viscosity at 40°C - 104°F temperature.

Nominal flow rating	standard	80 l/min	22 US gpm
	Flow Unloader valve configuration	120 l/min	32 US gpm
Max. pressure (1)		350 bar	5100 psi
Back pressure (max.) on outlet T port	with mechanical controls	20 bar	290 psi
	with hydraulic controls	20 bar	290 psi
	with electrohydraulic controls	5 bar	73 psi
Standard internal leakage A(B)->T	$\Delta p = 100 \text{ bar} - 1450 \text{ psi}$	8 cm ³ /min max.	0.5 in ³ /min max.
Fluid		Mineral oil	
Fluid temperature range	with NBR (BUNA-N) seals	from -20°C to 80°C	from -4°F to 176°F
Viscosity	operating range	from 15 to 75 mm ² /s	from 15 to 75 cst
	min.	12 mm ² s	12 cst
	max.	400 mm ² s	400 cst
Contamination level		-/19/16 - ISO 4406	-/19/16 - ISO 4406
Environmental temperature for working conditions	with mechanical, hydraulic, electric and electrohydraulic devices	from -40°C to 60°C	from -40°F to 140°F
Tie rods tightening torque (ch 13)		40 Nm	29,5 Nm

NOTE - (1) Intermittent pressure at max. 250,000 cycles with specific internal testing.

- For different working conditions please, contact our Sales Department.

Standard thread

REFERENCE STANDARD				
		BSP	UN-UNF	NPTF
THREAD ACCORDING TO		ISO 228/1	ISO 263	ANSI B1.20.3
		BS 2779	ANSI B1.1 unified	
CAVITY	ISO	1179-1	11926-1	
DIMENSION	SAE		J1926-1	J476a
ACCORDING TO	DIN	3852-2 shape X or Y		

PORTS THREADING		
	BSP	UN-UNF
P inlet	G 3/4	1 1/6-12 (SAE 12)
A and B ports	G 1/2	7/8-14 (SAE 10)
T outlet, HPCO carry-over	G 3/4	1 1/6-12 (SAE 12) - 7/8-14 (SAE 10)*
Y pilot	G 1/4	9/16-18 (SAE 6)
X drain	G 1/4	9/16-18 (SAE 6)
Hydraulic controls	G 1/4	9/16-18 (SAE 6)

NOTE (*) - on outlet section (mechanical and hydraulic controls)

Mechanical control configuration

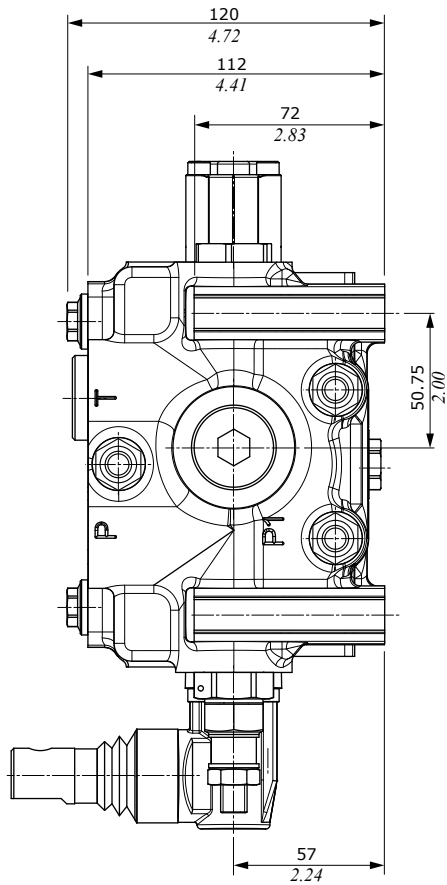

Right Inlet configuration example

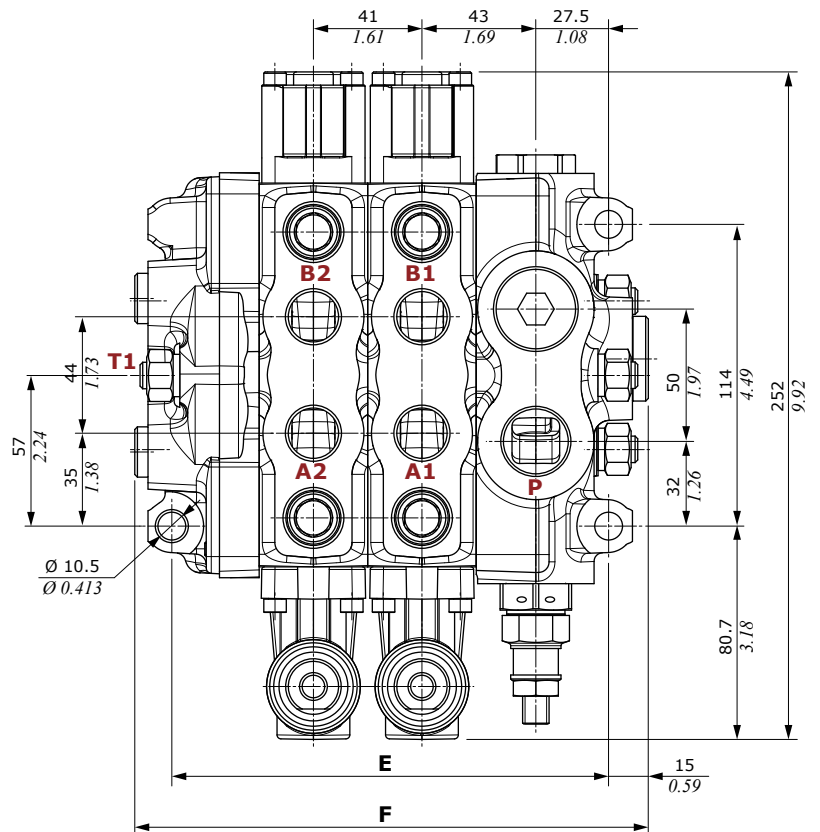

Left Inlet configuration example

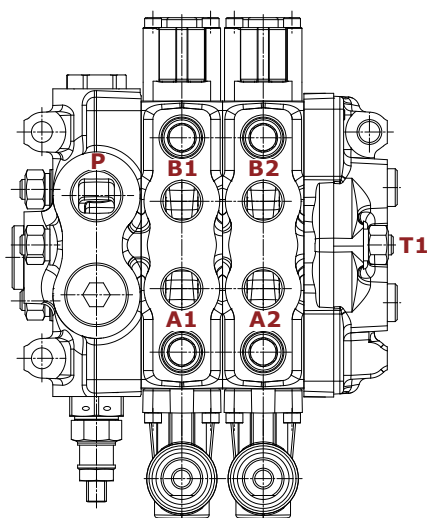

TYPE	E		F	
	mm	in	mm	in
DVS14/1	124	4.88	153	6.02
DVS14/2	165	6.50	194	7.64
DVS14/3	206	8.11	235	10.43
DVS14/4	247	9.72	276	10.87
DVS14/5	288	11.34	317	12.48
DVS14/6	329	12.95	358	14.09
DVS14/7	370	14.57	399	15.71
DVS14/8	411	16.18	440	17.32
DVS14/9	452	17.80	481	18.94
DVS14/10	493	19.41	522	20.55

NOTE: Drawings and dimensions are referred to a **BSP** threading configuration.

Dimensional data

Electrohydraulic control configuration

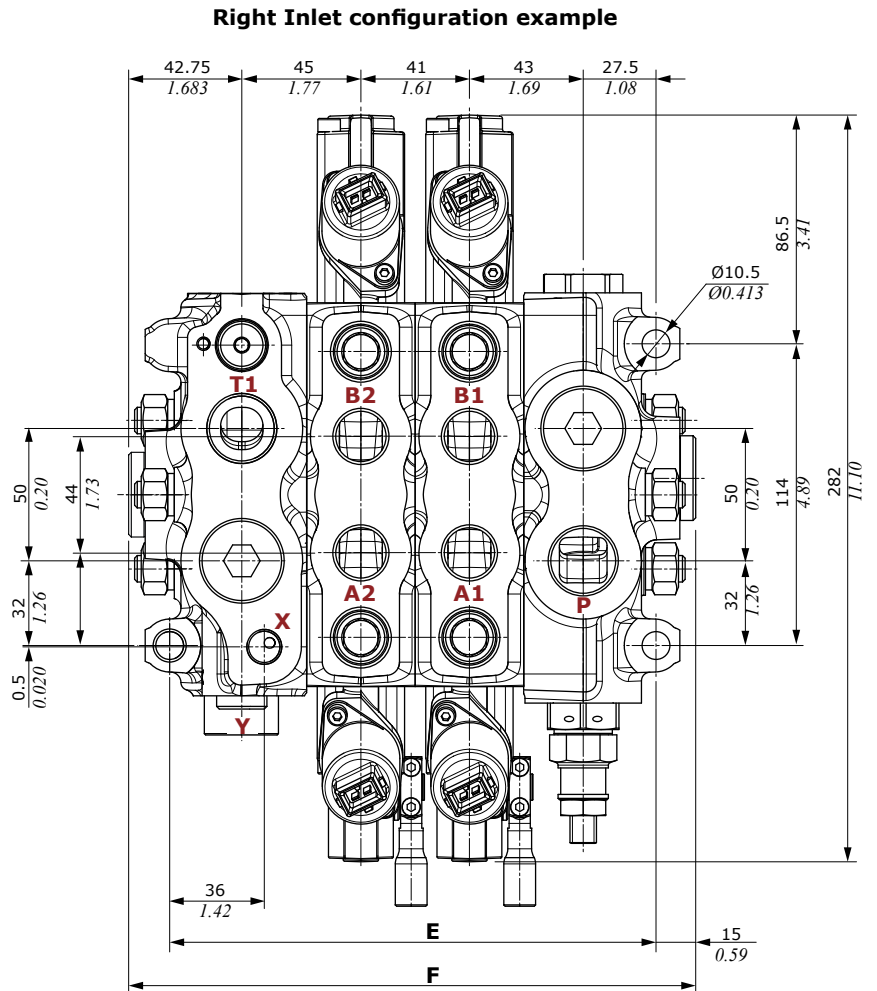
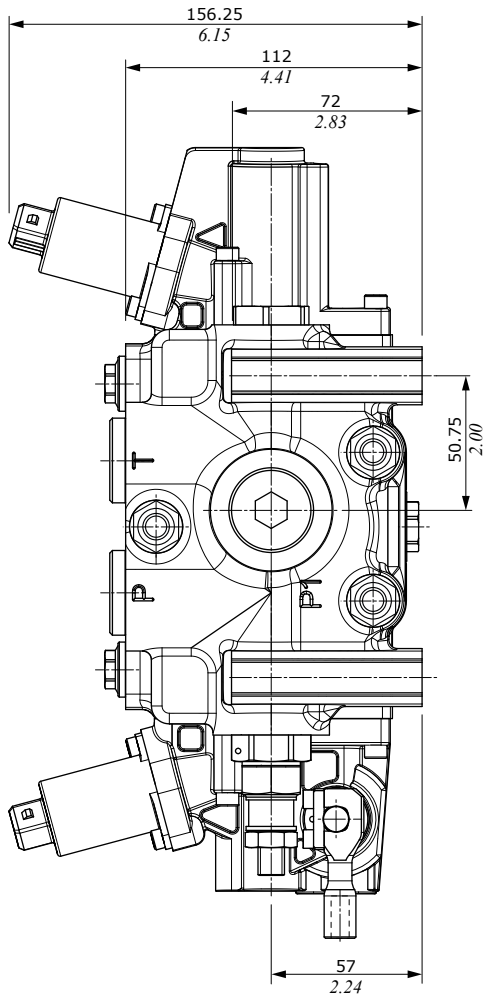

Left Inlet configuration example

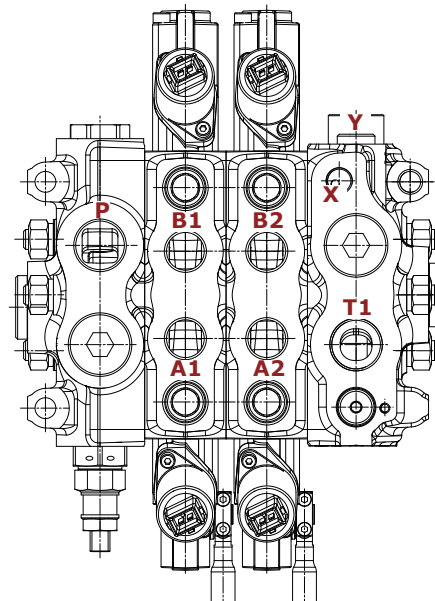

TYPE	E		F	
	mm	in	mm	in
DVS14/1	144	5.67	173.25	6.82
DVS14/2	185	7.28	214.25	8.44
DVS14/3	226	8.90	255.25	10.05
DVS14/4	267	10.51	296.25	11.66
DVS14/5	308	12.13	337.25	13.28
DVS14/6	349	13.74	378.25	14.89
DVS14/7	390	15.35	419.25	16.51
DVS14/8	431	16.97	460.25	18.12
DVS14/9	472	18.58	501.25	19.73
DVS14/10	513	20.20	542.25	21.35

NOTE: Drawings and dimensions are referred to a **BSP** threading configuration.

Performances

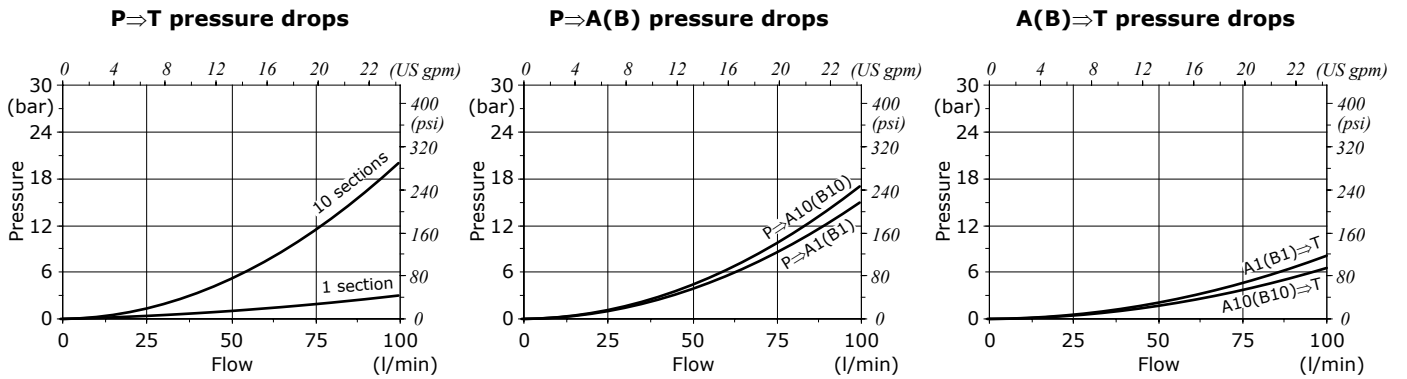

Hydraulic circuit

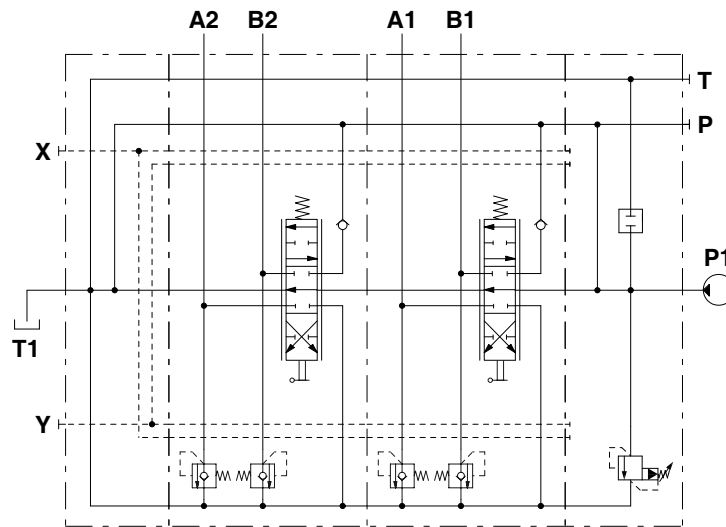

Right Inlet valve with mechanical controls configuration:
 DVS14/2/MR-V1A(175)V3B-A-G05/W001A-H001-F001A-RP1-G04.03TF-PA(100)\03TF-PB(100)/
 W001A-H001-F001A-RP1-G04.03TF-PA(100)\03TF-PB(100)/KZM1-G05

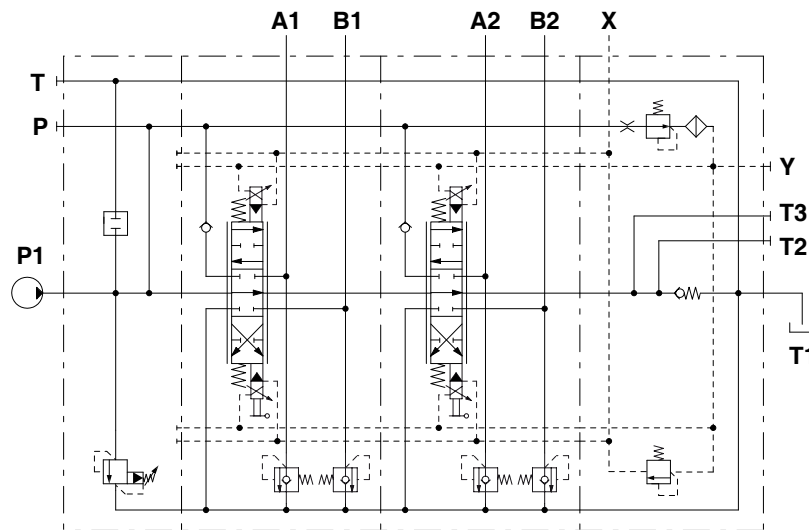

Left Inlet valve with electrohydraulic controls configuration:
 DVS14/2/ML-V1A(200)V7B-C12-A-G05/W001A-HP04-FP04-B12AJ-RP1-G04.03TF-PA(100)\03TF-PB(100)/
 W001A-HP04-FP04-B12AJ-RP1-G04.03TF-PA(100)\03TF-PB(100)/KZP1-G05

Complete section ordering codes

Mechanical/hydraulic controls valve configuration example

Right Inlet: R
Left Inlet: L

DVS14/2/MR-V2A(200)V3B-A-G05/W001A-H001-F001A-RP1-G04.05TF-PA\05TF-PB/....

Nr. of working sections

1

2

W001A-HP05A-RP2-G04/KZM1-G05-<P006/2>

2

3

Valve is painted as standard, with one coat of Primer RAL9005 black antitrust paint

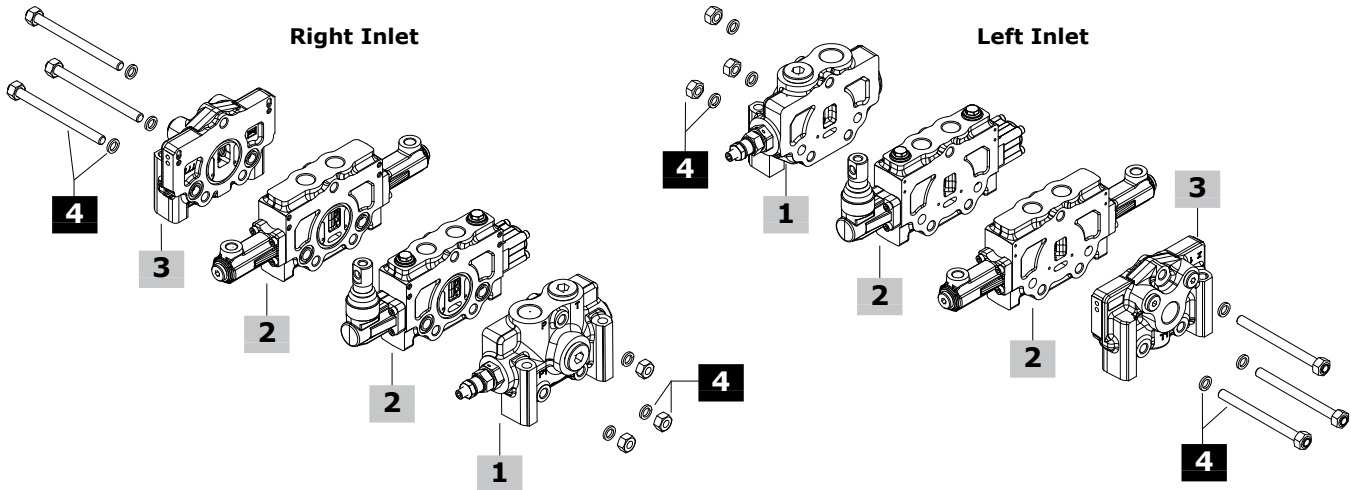

Mechanical/electrohydraulic controls valve configuration example with Left Inlet

DVS14/2/ML-V2A(200)V3B-A-G05/ **1**

2 **W001A-H001-F001A-RP1-G04.05TF-PA\05TF-PB/**

2 **W001A-HP04-FP04-B12AJ-RP1-G04.05TF-PA\05TF-PB/**

3 **KZP1-G05-<P006/2>**

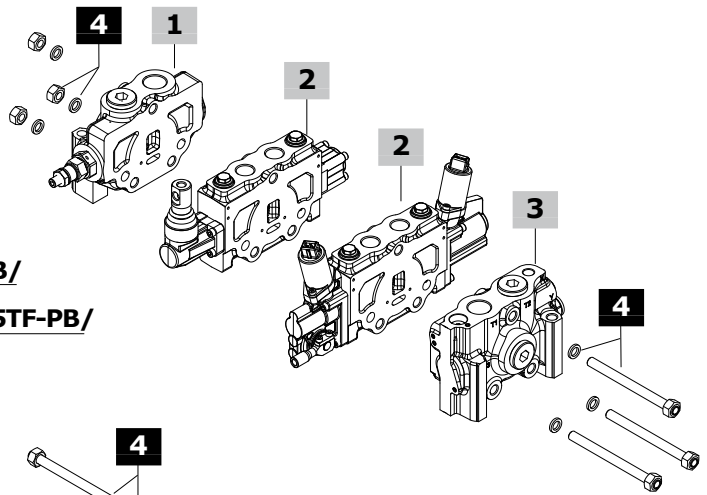

Electrohydraulic controls valve configuration example with Right Inlet

DVS14/2/MR-V2A(200)V3B-A-G05/ **1**

2 **W001A-HP04-FP04-B12AJ-RP1-G04.05TF-PA\05TF-PB/**

2 **W001A-HP04-FP04-B12AJ-RP1-G04.05TF-PA\05TF-PB/**

3 **KZP1-G05-<P006/2>**

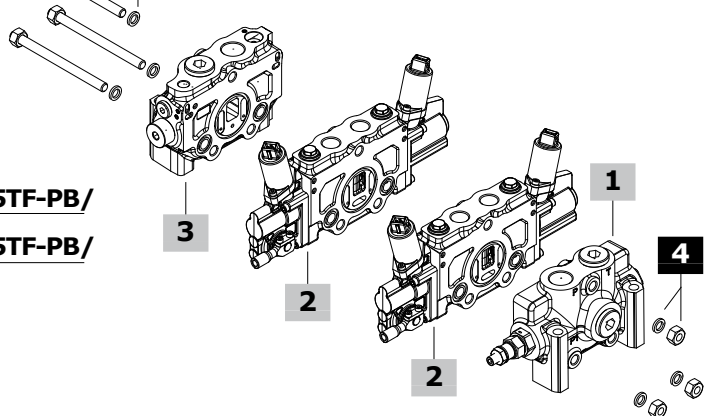

1 Inlet section * page 10

Right Inlet configuration

TYPE: **MR-V2A(200)-V3B-A-G05** CODE: SHE140006
 DESCRIPTION: Upper inlet open, side inlet and upper outlet plugged, with pilot operated main relief valve

TYPE: **MR-V3A-V3B-A-G05** CODE: SHE140007
 DESCRIPTION: Upper inlet open, side inlet and upper outlet plugged, without main relief valve

Left Inlet configuration

TYPE: **ML-V2A(200)-V3B-A-G05** CODE: SHE140001
 DESCRIPTION: Upper inlet open, side inlet and upper outlet plugged, with pilot operated main relief valve

TYPE: **ML-V3A-V3B-A-G05** CODE: SHE140002
 DESCRIPTION: Upper inlet open, side inlet and upper outlet plugged, without main relief valve

2 Working section * page 14

Right Inlet configuration

TYPE: **SD\W001A-H001-F001A-RP1-G04.05TF-PA/05TF-PB**
 CODE: SHL140015

DESCRIPTION: Parallel circuit with port valves arrangement (seat plugged), 3 positions double acting spool, lever control and spring return to neutral position

TYPE: **SD\W001A-HP05A-RP2-G04**
 CODE: SHL140019

DESCRIPTION: Parallel circuit without port valves arrangement, 3 positions double acting spool, proportional hydraulic control with spring return in neutral position

TYPE: **SD\W001A-HP04-FP04-B12AJ-RP1-G04.05TF-PA/05TF-PB**
 CODE: SHL140017

DESCRIPTION: Parallel circuit with port valves arrangement (seat plugged), 3 positions double acting spool, 12VDC proportional electrohydraulic control (AMP JPT connector) with lever and spring return to neutral position

TYPE: **SD\W001A-HP04-FP04-B12AJ-RP2-G04**
 CODE: SHL140018

DESCRIPTION: As previous one without port valves arrangement

Left Inlet configuration

TYPE: **SS\W001A-H001-F001A-RP1-G04.05TF-PA/05TF-PB**
 CODE: SHL140009

DESCRIPTION: Parallel circuit with port valves arrangement (seat plugged), 3 positions double acting spool, lever control and spring return to neutral position

TYPE: **SS\W001A-HP05A-RP2-G04**
 CODE: SHL140005

DESCRIPTION: Parallel circuit without port valves arrangement, 3 positions double acting spool, proportional hydraulic control with spring return in neutral position

TYPE: **SS\W001A-HP04-FP04-B12AJ-RP1-G04.05TF-PA/05TF-PB**
 CODE: SHL140001

DESCRIPTION: Parallel circuit with port valves arrangement (seat plugged), 3 positions double acting spool, 12VDC proportional electrohydraulic control (AMP JPT connector) with lever and spring return to neutral position

TYPE: **SS\W001A-HP04-FP04-B12AJ-RP2-G04**
 CODE: SHL140003

DESCRIPTION: As previous one without port valves arrangement

3 Outlet section * page 31

TYPE CODE DESCRIPTION

For all control types, without pressure reducing valve

KZM1-G05 SHU140009 T1 port open, Y pilot and drain X plugged

KZM2-G05 SHU140010 All ports plugged

KZM3-G05 SHU140017 All ports open

KZM4-G05 SHU140018 T1 port plugged, Y pilot and drain X open

KZMH1-G05 SHU140019 With carry-over (HPCO) on T1 port, Y pilot and drain X plugged

KZMH2-G05 SHU140020 With carry-over (HPCO) on T1 port, Y pilot and drain X open

For electrohydraulic control, with pressure reducing valve

KZP1-G05 SHU140001 With backpressure valve, upper T1 port and X drain open, T2-T3 outlets and Y pilot plugged

KZP3-G05 SHU140002 With backpressure valve, X drain open, ports and Y pilot plugged

KZP6-G05 SHU140021 Without backpressure valve, upper T1-T2 ports and Y pilot plugged, side T3 port and X drain open

KZPH1-G05 SHU140022 Without backpressure valve, carry-over (HPCO) on upper T2 port, upper T1 port and drain X open, side T3 port and Y pilot plugged

KZPH2-G05 SHU140023 Without backpressure valve, carry-over (HPCO) on side T3 port, upper T1 port and drain X open, upper T2 port and Y pilot plugged

4 Tie rods kit

CODE DESCRIPTION

For valve with KZM type outlet section

5TIRDVS1401 For 1 section valve

5TIRDVS1402 For 2 sections valve

5TIRDVS1403 For 3 sections valve

5TIRDVS1404 For 4 sections valve

5TIRDVS1405 For 5 sections valve

5TIRDVS1406 For 6 sections valve

5TIRDVS1407 For 7 sections valve

5TIRDVS1408 For 8 sections valve

5TIRDVS1409 For 9 sections valve

5TIRDVS1410 For 10 sections valve

For valve with KZP type outlet section

5TIRDVS1401EI For 1 section valve

5TIRDVS1402EI For 2 sections valve

5TIRDVS1403EI For 3 sections valve

5TIRDVS1404EI For 4 sections valve

5TIRDVS1405EI For 5 sections valve

5TIRDVS1406EI For 6 sections valve

5TIRDVS1407EI For 7 sections valve

5TIRDVS1408EI For 8 sections valve

5TIRDVS1409EI For 9 sections valve

5TIRDVS1410EI For 10 sections valve

NOTE (*): Codes are referred to a **BSP** thread

Part ordering codes

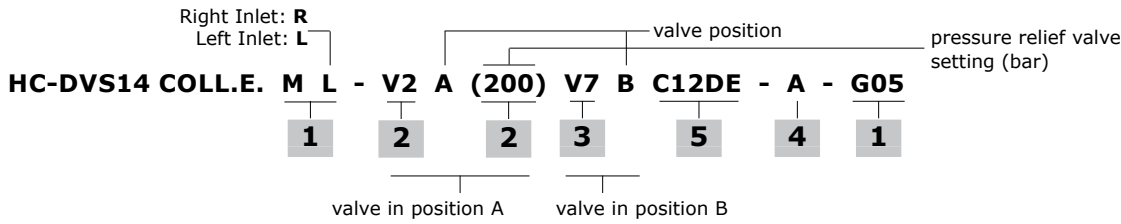

Right Inlet configuration example

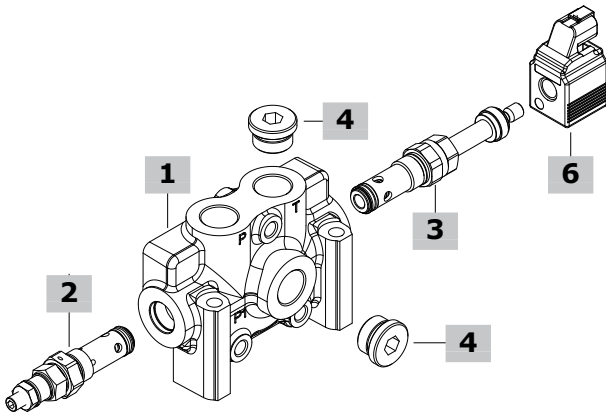

Left Inlet configuration example

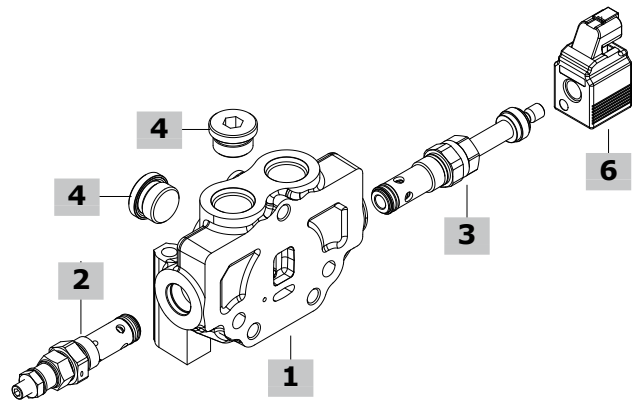

1 Section body * page 11

TYPE	CODE	DESCRIPTION
ML-G05	4205C3002	Inlet section body, G3/4 thread

2 Main relief valve page 12

TYPE	CODE	DESCRIPTION
V2(200)	91501C302	Pilot operated, setting range from 50 to 350 bar (725 to 5100 psi)
V3	4301C3001	Valve blanking plug

3 Secondary inlet valves page 13

TYPE	CODE	DESCRIPTION
V4	91505C301	Anticavitation valve
V6	91504C301*	Hydraulic operated unloading valve
V7	91504C302	Solenoid operated unloading valve (without coil), "push&twist" emergency actuation
V8	91504C303	As previous one without emergency actuation
V3	4301C3001	Valve blanking plug
V13	4301C3002*	Valve blanking plug with G1/4 port for pressure gauge arrangement

4 Port configuration * page 12

TYPE	CODE	DESCRIPTION
A	430000020	G3/4 plug: nr.2 - Upper P inlet port open, side P1 inlet port and upper T outlet port plugged
B	430000020	G3/4 plug: nr.1
	300007006	G3/4 plug with G1/4 press. gauge arrangement: n.1 Upper P inlet port open, side P1 inlet port with press. gauge arrangement, upper T outlet port plugged
C	430000020	G3/4 plug: nr.1 - Side P1 inlet port open, upper P inlet port and T outlet port plugged
D	430000020	G3/4 plug: nr.1
	300007006	G3/4 plug with G1/4 press. gauge arrangement: n.1 Side P1 inlet port open, upper P inlet port with press. gauge arrangement, upper T outlet port plugged
E	430000020	G3/4 plug: nr.1 - Side P1 inlet port plugged, upper P inlet port and T outlet port open
F	300007006	G3/4 plug with G1/4 press. gauge arrangement: n.1 Side P1 inlet port with press. gauge arrangement, upper P inlet port and T outlet port open
G	430000020	G3/4 plug: nr.1 - Side P1 inlet port and upper T outlet port open, upper P inlet port plugged
H	300007006	G3/4 plug with G1/4 press. gauge arrangement: n.1 Side P1 inlet port and upper T outlet port open, upper P inlet port with press. gauge arrangement

5 Coils page 44

TYPE	CODE	DESCRIPTION
C12DI	4SLE001200A	BER type, 12 VDC, ISO4400 connector
C12AJ	4SLE001203A	BER type, 12 VDC, AMP JPT connector
C12DE	4SLE001202A	BER type, 12 VDC, Deutsch connector

For complete available coil code list see page 45.

NOTE (*): Codes are referred to a **BSP** thread

Dimensional data and hydraulic circuit

MR type inlet section example
 dimensions are the same for MR and ML type

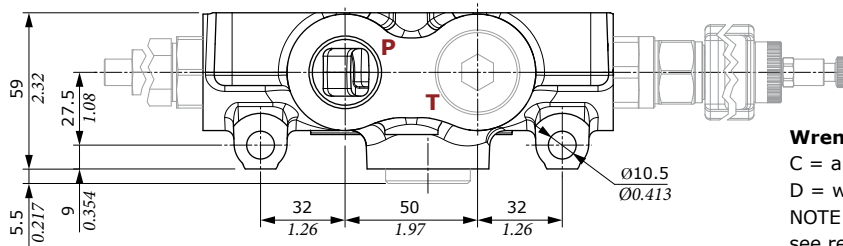
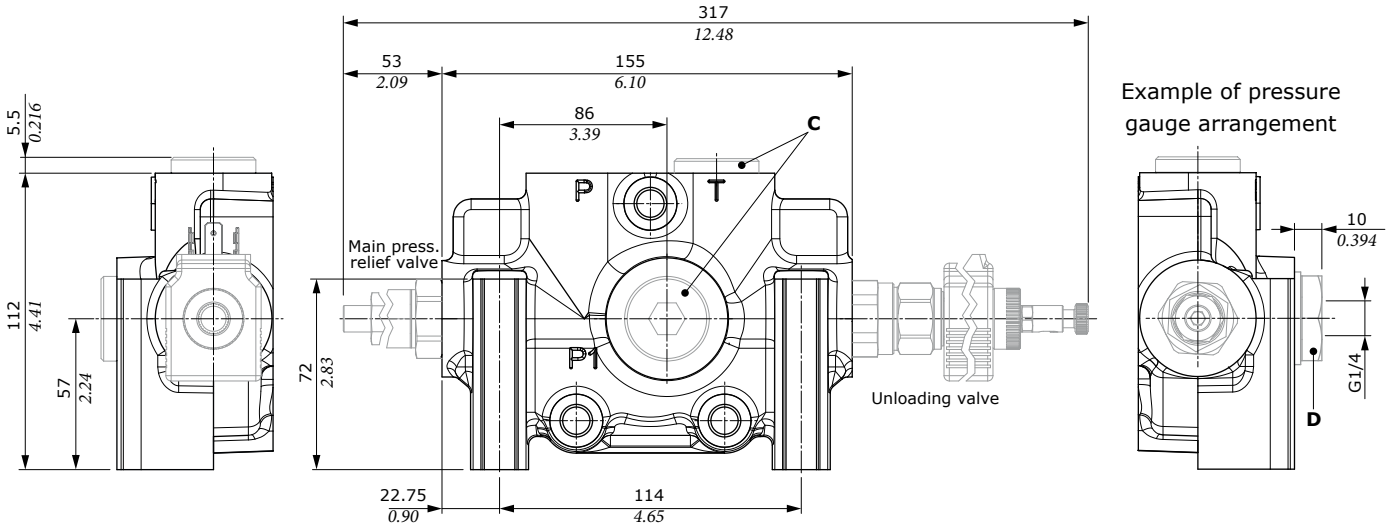

Wrenches and tightening torques
 C = allen wrench 12 - 90 Nm (66 lbf_t)
 D = wrench 32 - 90 Nm (66 lbf_t)
 NOTE: for valves wrench and torque, see related pages

MRA section type, upper inlet

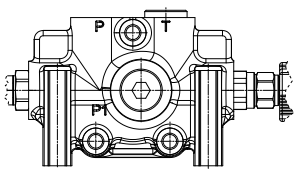

MRC section type, side inlet

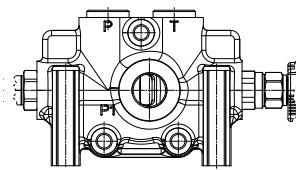

MLA section type, upper inlet

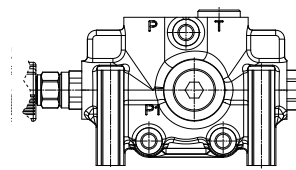

MLC section type, side inlet

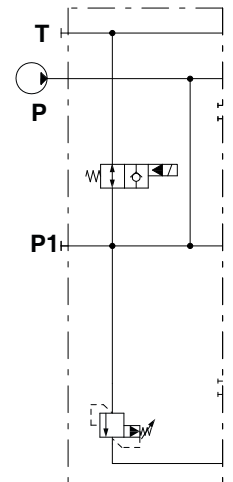
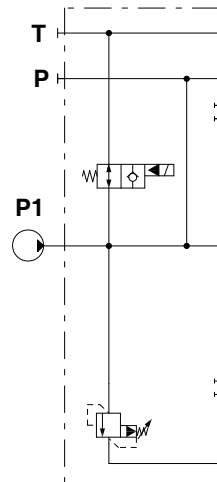
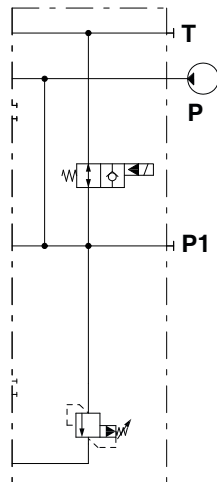
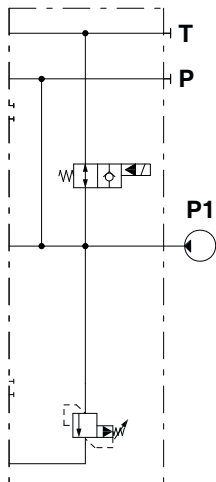
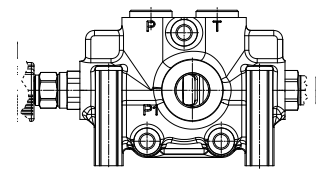

Port configuration

Type	P inlet port	P1 inlet port	T outlet port	
A	open	closed	closed	
B	open	pressure gauge arrangement	closed	
C	closed	open	closed	
D	pressure gauge arrangement	open	closed	
E	open	closed	open	
F	open	pressure gauge arrangement	open	
G	closed	open	open	
H	pressure gauge arrangement	open	open	

Inlet valves

Main relief valve

Drawings show valve on **MR** type inlet section.

V2 type
Pilot operated

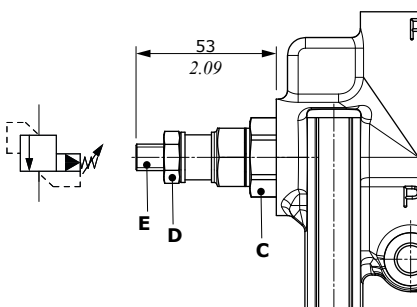

V3 type
Valve blanking plug

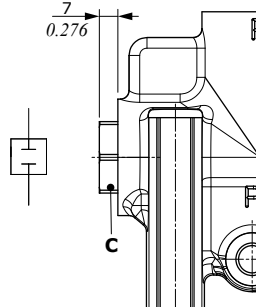

Setting example

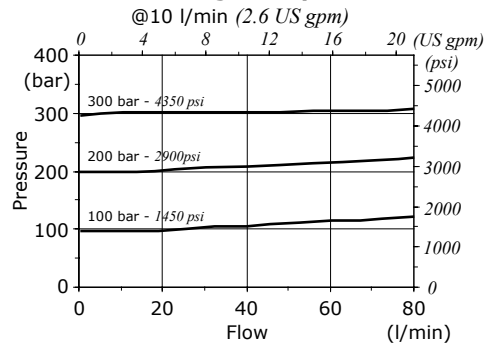

Wrenches and tightening torques

- C = wrench 27 - 80 Nm (59 lbft)
- D = wrench 16 - 25 Nm (18.4 lbft)
- E = allen wrench 5

Secondary inlet valves

Drawings show valves on **MR** type inlet section.

Solenoid operated unloading valve

V8 type: push&twist emergency actuation

V7 type: without emergency actuation

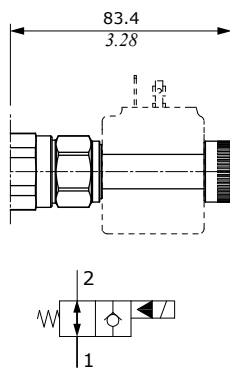
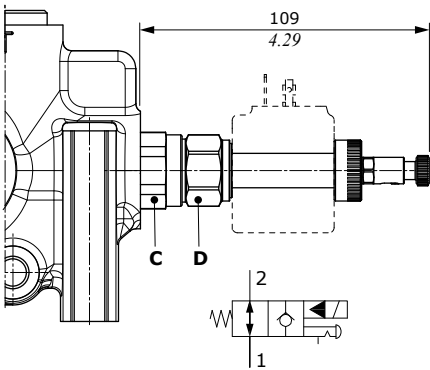

Valve features

- Nominal flow : 2 l/min (0.53 US gpm)
- Max. pressure. : 350 bar (5100 psi)
- Max. internal leakage.. : 0.25 cm³/min @ 210 bar
(0.015 in³/min @ 3050 psi)

For **BER** type coils, see page 44

Wrenches and tightening torques

C = wrench 27 - 80 Nm (59 lbft)

D = wrench 24 - 30 Nm (22 lbft)

**V13 type
Plug with pressure
gauge arrangement**

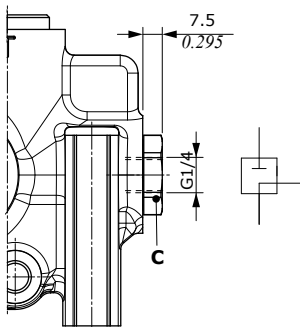

**V3 type
Valve blanking plug**

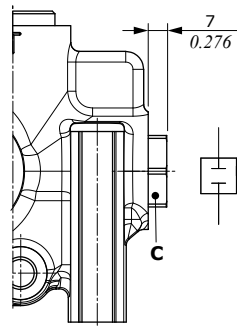

**V4 type
Anticavitation valve**

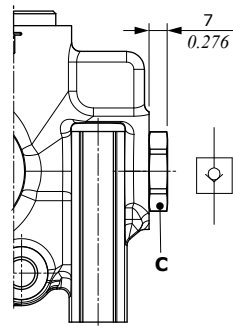

**V6 type
Hydraulic operated
unloading valve**

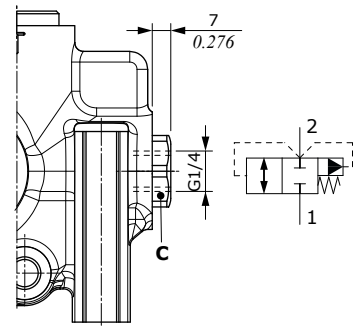

**V6-V7-V8 valves pressure drops
2 → 1**

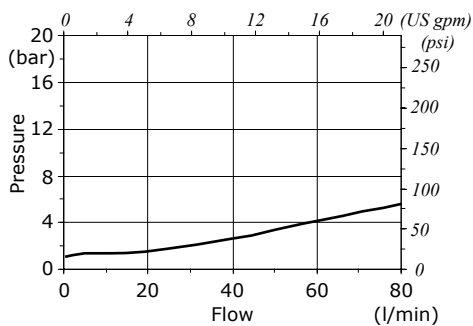

V4 valve pressure drops

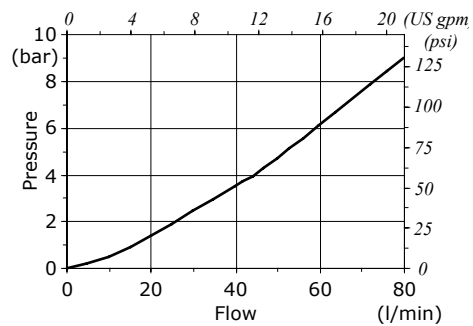

Part ordering codes

Mechanical control valve configuration example for Left Inlet

Right Inlet: **D**
Left Inlet: **S**

HC-DVS14 - SS/W001A-H001-F001

2A 3A 4A

valve setting (bar)

port valve position

-RP1-G04.03TF-PA(100)\03TF-PB(80)

1A

6

6

6

6

valve on A port

valve on B port

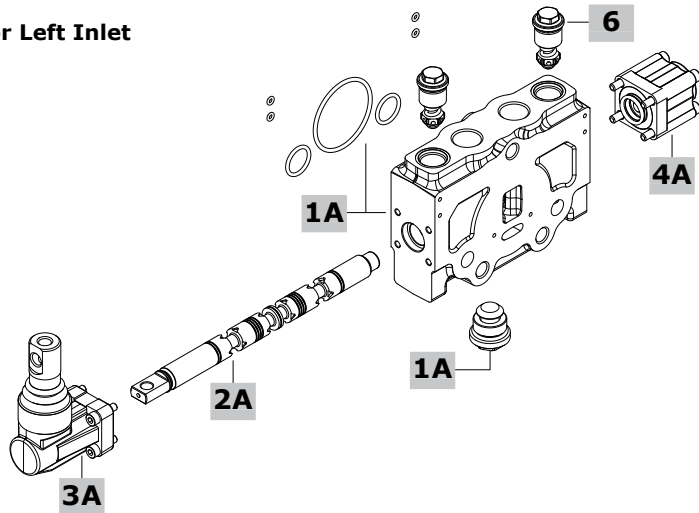

Hydraulic control valve configuration example for Right Inlet

HC-DVS14-SD/W001A-HP05A-RP1-G04.05TF-PA\05TF-PB

2B 5 1A 6 6

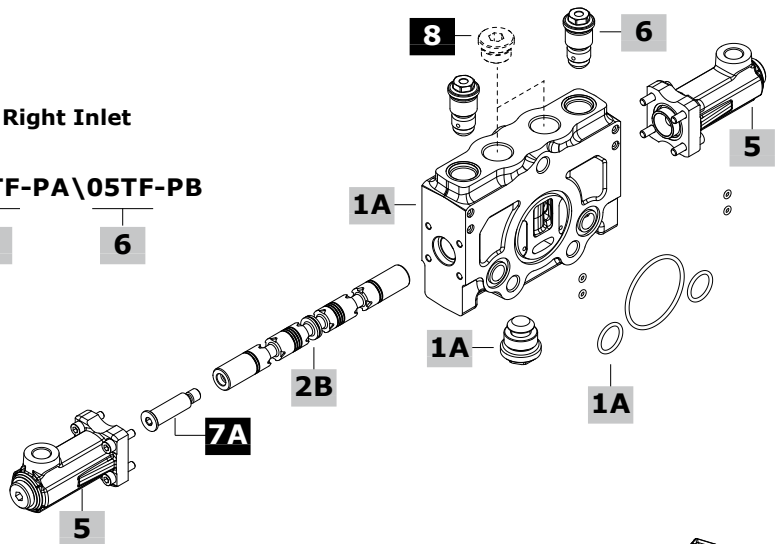

Electrohydraulic control valve configuration example for Right Inlet

HC-DVS14-SD/W001A-HP04-FP04-B12AJ

2B 3B 4B 3B-4B

-RP1-G04.02TF-PA\02TF-PB

1B

6

6

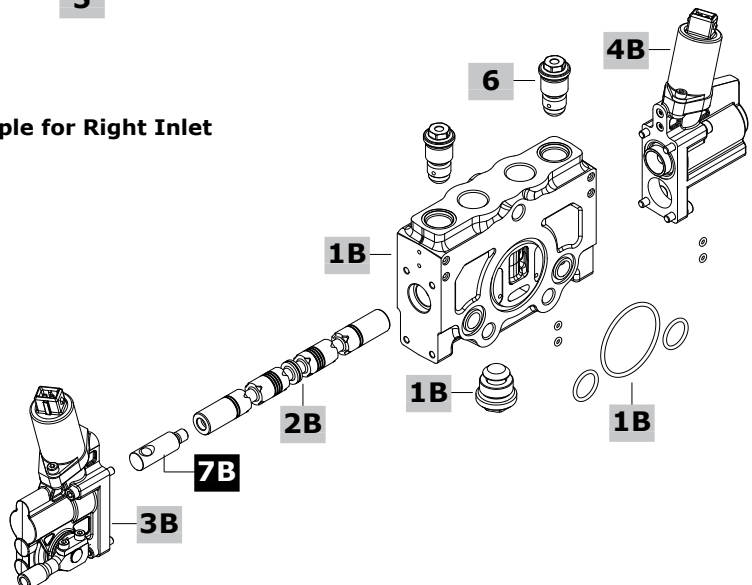

MECHANICAL CONTROL SECTION

1A Section body kit * page 17

TYPE: **RP1-G04** CODE: 5EL4208C3003
 DESCRIPTION: Parallel circuit, with port valves arrangement
 TYPE: **RP2-G04** CODE: 5EL4208C3014
 DESCRIPTION: Parallel circuit, without port valves arrangement

3A A side controls page 21

TYPE	CODE	DESCRIPTION
H001	3203C3001	Lever box control
	3203C3011	Lever box control for floating circuit. Spool type W012A and F005A control are required
H002	3203C3001	Lever box control, assembled rotated 180°
	3203C3011	Lever box control for floating circuit, assembled rotated 180°. Spool type W012A and F005A control are required
H004	3203C3013	Without lever box, with dust proof rubber bellow
	3203C3014	As previous one, for floating circuit. Spool type W012A and F005A control are required

Joystick control

H009-H120	3206C3003	For Right Inlet, pivot on 1 st section. Obligatory description for 2 nd section: H120.
H120-H012	3206C3003	For left Inlet, pivot on 2 nd section. Obligatory description for 1 st section: H120.
H120-H010	3206C3004	For Right Inlet, pivot on 2 nd section. Obligatory description for 1 st section: H120.
H011-H120	3206C3004	For left Inlet, pivot on 1 st section. Obligatory description for 2 nd section: H120.

2A Spools page 18

TYPE	CODE	DESCRIPTION
Double acting spools		
W001A	4212C3022	3 positions, A and B closed in neutral position, for 70 l/min (18.5 US gpm)
W001B	4212C3023	As previous one, for 40 l/min (10.6 US gpm)
W012A	4212C3062	4 positions, for floating circuit. Special RPF1 body kit is required; contact Sales Department. Dedicated A and B side controls are required

4A B side controls page 23

TYPE	CODE	DESCRIPTION
With spring return to neutral position		
F001A	3207C3006	3 positions
F001B	3207C3007	As F001A type, with light spring
F001C	3207C3008	As F001A type, with heavy spring
F001ASL	3200C3005	3 pos., with analog spool position sensor(#)
F001ASD	3200C3004	3 pos., with digital spool position sensor(#)
F002A	3208C3005	3 positions, detent in A and B
F003A	3208C3006	3 positions, detent in A
F004A	3208C3007	3 positions, detent in B
F013A	3207C3009	3 positions, double control arrangement
F005A	3208C3004	4 positions, detent in 4 th position Spool type W012A and dedicated A side controls are required.

Note (#): For sensors features please see page 20.

HYDRAULIC CONTROL SECTION

1A Section body kit * page 17

See body kit for mechanical controls

2B Spools page 18

See spool for electrohydraulic controls

7A Spool end kit page 19

CODE	DESCRIPTION
420311025	Spool end for hydraulic controls

5 A+B controls* page 28

TYPE	CODE	DESCRIPTION
With spring return to neutral position		
HP05A	3205C3015	With upper ports
HP05C	3205C3017	With side ports
HP05L	3205C3019	With upper ports and spool stroke limiter

PORT VALVES AND ACCESSORIES

6 Port valves page 30

TYPE	CODE	DESCRIZIONE
05TF	4300C3002	Valve blanking plug
02TF	915089001	Anticavitation valve

Fixed setting antishock and anticavitation valves:
 setting is referred to 10 l/min (2.6 US gpm) flow

TYPE: 03TF(100)	CODE: 915870	100
	└─ setting (bar)	└─ setting (bar)

SETTING RANGE:
 From 40 to 350 bar (580 to 5100 psi), 10 bar (145 psi) step

8 Plug for single acting

CODE	DESCRIPTION
430000019	G1/2 plug

NOTE (*): Codes are referred to **BSP** thread

Part ordering codes

ELECTROHYDRAULIC CONTROL SECTION

1B Section body kit * page 20

TYPE: **RP1-G04** CODE: 5EL4208C3002
 DESCRIPTION: Parallel circuit with port valves arrangement
 TYPE: **RP2-G04** CODE: 5EL4208C3011
 DESCRIPTION: Parallel circuit without port valves arrangement

2B Spools page 21

TYPE	CODE	DESCRIPTION
Double acting spools		
W001A	4212C3001	3 positions, A and B closed in neutral position, for 70 l/min (18.5 US gpm)
W001B	4212C3002	As previous one, for 40 l/min (10.6 US gpm)
W002A	4212C3003	3 positions, A and B to tank in neutral position, for 70 l/min (18.5 US gpm)
W002B	4212C3004	As previous one, for 40 l/min (10.6 US gpm)
W003A	4212C3005	3 positions, A to tank and B closed in neutral position, for 70 l/min (18.5 US gpm)
W003B	4212C3006	As previous one, for 40 l/min (10.6 US gpm)
W004A	4212C3005	3 positions, A closed and B to tank in neutral position, for 70 l/min (18.5 US gpm)
W004B	4212C3006	As previous one, for 40 l/min (10.6 US gpm)
W012A	4212C3013	4 positions, for floating circuit.

Special RPF1 body kit is required; contact Sales Department

Single acting spools: G1/2 plug is required

W005A	4212C3007	3 positions, single acting in A, for 70 l/min (18.5 US gpm)
W005B	4212C3008	As previous one, for 40 l/min (10.6 US gpm)
W006A	4212C3007	3 positions, single acting in B, for 70 l/min (18.5 US gpm)
W006B	4212C3008	As previous one, for 40 l/min (10.6 US gpm)

Double acting spools partially to tank

W001AK10	4212C3059	Double acting, 3 positions, A to tank in neutral position, for 70 l/min (18.5 US gpm)
W001AY10	4212C3059	Double acting, 3 positions, B to tank in neutral position, for 70 l/min (18.5 US gpm)
W001AJ10	4212C3058	Double acting, 3 pos., A and B to tank in neutral position, for 70 l/min (18.5 US gpm)
W001BJ10	4212C3009	Double acting, 3 positions, A and B to tank in neutral position, for 40 l/min (10.6 US gpm)
W001BK10	4212C3021	Double acting, 3 positions, A to tank in neutral position, for 40 l/min (10.6 US gpm)
W001BY10	4212C3021	Double acting, 3 positions, B to tank in neutral position, for 40 l/min (10.6 US gpm)

7B Spool end kit page 19

CODE	DESCRIPTION
422501293	Spool end for electrohydraulic controls, standard type
422501294	As previous one, milled type

3B A side controls page 26

TYPE	CODE	DESCRIPTION
HP07-B12AJ	322593026	Without lever, 12VDC, AMP connector
HP07-B24AJ	322593027	As previous one, 24VDC
HP07-B12DE	322593028	Without lever, 12VDC, Deutsch connector
HP07-B24DE	322593029	As previous one, 24VDC
HP07L-B12AJ	322593046	Without lever, 12VDC, with spool stroke limiter, AMP connector
HP07L-B24AJ	322593047	As previous one, 24VDC
HP07L-B12DE	322593048	Without lever, 12VDC, with spool stroke limiter, Deutsch connector
HP07L-B24DE	322593049	As previous one, 24VDC
HP04-B12AJ	322593018	With lever, 12VDC, AMP connector
HP04-B24AJ	322593019	As previous one, 24VDC
HP04-B12DE	322593020	With lever, 12VDC, Deutsch connector
HP04-B24DE	322593021	As previous one, 24VDC
HP04L-B12AJ	322593022	With lever, 12VDC, with spool stroke limiter, AMP connector
HP04L-B24AJ	322593023	As previous one, 24VDC
HP04L-B12DE	322593024	With lever, 12VDC, with spool stroke limiter, Deutsch connector
HP04L-B24DE	322593025	As previous one, 24VDC

4B B side controls page 27

TYPE	CODE	DESCRIPTION
With spring return to neutral position		
FP04-B12AJ	3225C3106	12VDC, AMP connector
	3225C3301	As previous one, for floating circuit
		Spool type W012A is required
FP04-B24AJ	3225C3107	As previous one, 24VDC
	3225C3302	As previous one, for floating circuit
		Spool type W012A is required
FP04-B12DE	3225C3108	12VDC, Deutsch connector
	3225C3303	As previous one, for floating circuit
		Spool type W012A is required
FP04-B24DE	3225C3109	As previous one, 24VDC
	3225C3304	As previous one, for floating circuit
		Spool type W012A is required
FP04SL-B12AJ	3225C3119	12VDC, analog spool position sensor, AMP connector
FP04SL-B24AJ	3225C3120	As previous one, 24VDC
FP04SL-B12DE	3225C3121	12VDC, analog spool position sensor, Deutsch connector
FP04SL-B24DE	3225C3122	As previous one, 24VDC
FP04SD-B12AJ	3225C3123	12VDC, digital spool position sensor, AMP connector
FP04SD-B24AJ	3225C3124	As previous one, 24VDC
FP04SD-B12DE	3225C3125	12VDC, digital spool position sensor, Deutsch connector
FP04SD-B24DE	3225C3126	As previous one, 24VDC
FP04L-B12AJ	3225C3110	Spool stroke limiter, 12VDC, AMP connector
FP04L-B24AJ	3225C3111	As previous one, 24VDC
FP04L-B12DE	3225C3112	Spool stroke limiter, 12VDC, Deutsch conn.
FP04L-B24DE	3225C3113	As previous one, 24VDC

NOTE (*): Codes are referred to **BSP** thread

Dimensional data and hydraulic circuit

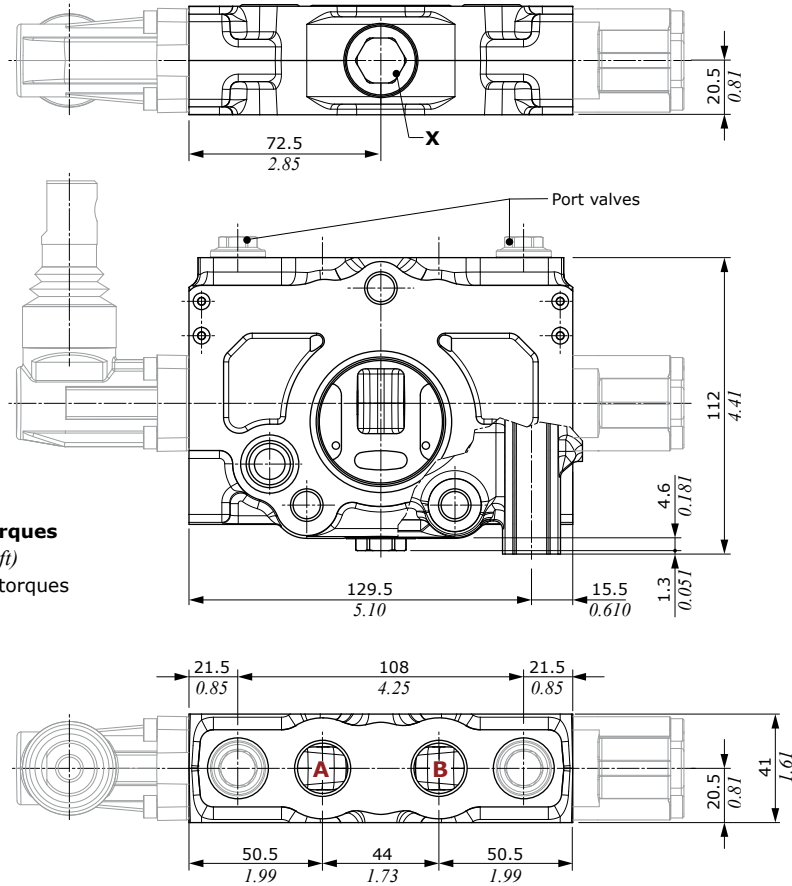

Wrenches and tightening torques
 X = wrench 17 - 130 Nm (96 lbft)
 NOTE: for valve wrenches and torques see related pages

SD\RP2 type without port valves arrangement **SD\RP1 type** with port valves arrangement **SS\RP2 type** without port valves arrangement **SS\RP1 type** with port valves arrangement

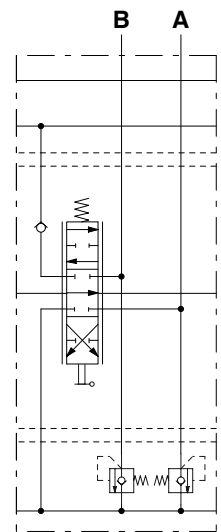
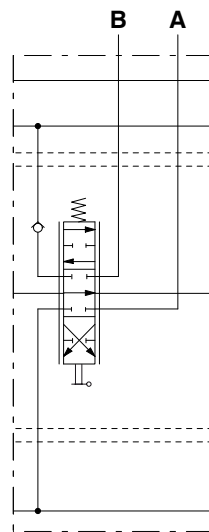
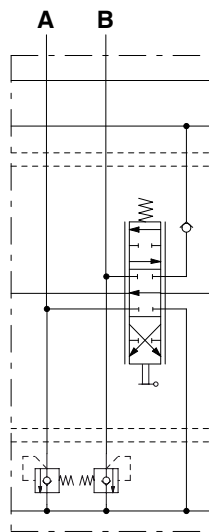
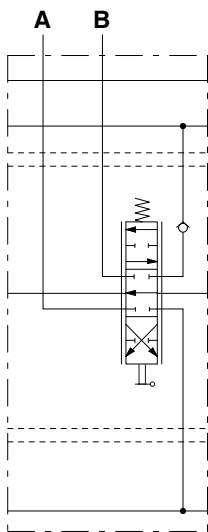

Spools

Standard spools

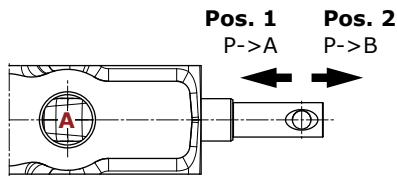

W001A/W001B types
Double acting, 3 positions,
A and B closed in neutral position

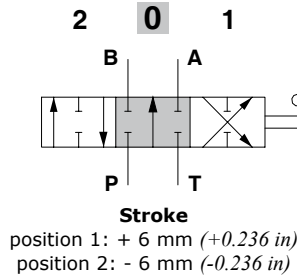

W001A/W001B types
metering curves

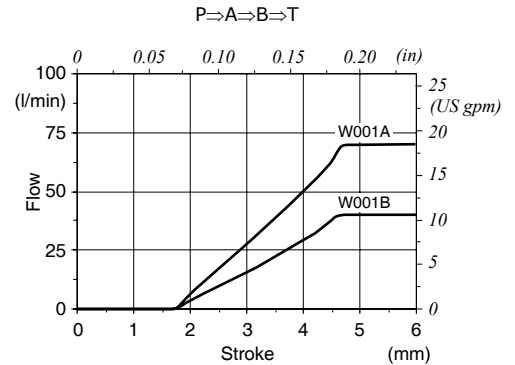

W002A/W002B types
Double acting, 3 positions,
A and B to tank in neutral position

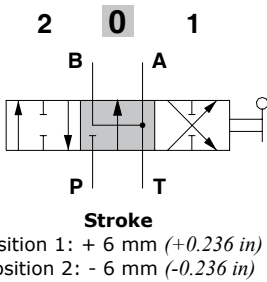

W003A/W003B types
Double acting, 3 positions, B closed
and A to tank in neutral position

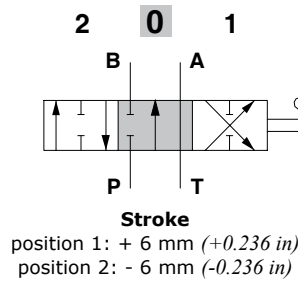

W004A/W004B types
Double acting, 3 positions, A closed
and B to tank in neutral position

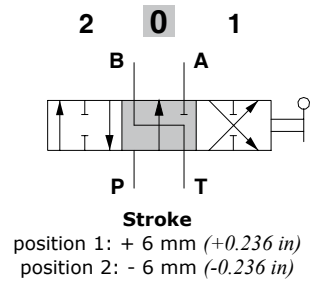

W005A/W005B types
Single acting in A, 3 positions

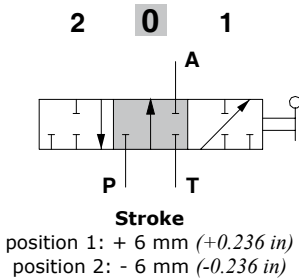

W006A/W006B types
Single acting in B, 3 positions

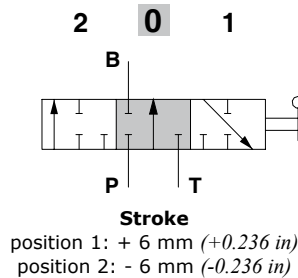

W012A type
Double acting, 4 positions,
float in 4th position

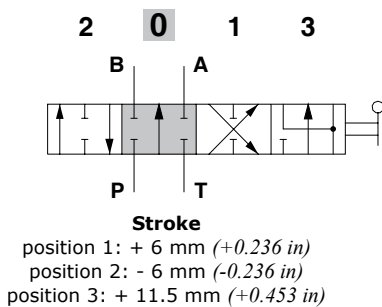

W012A type metering curve
P→A→B→T

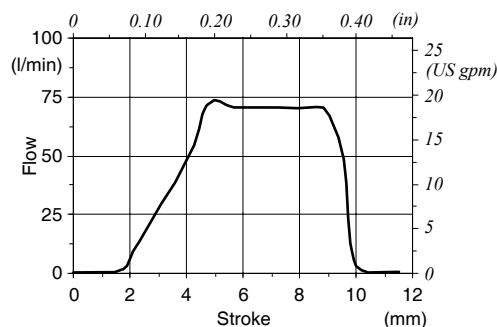

Partially to tank spools

W001AJ10/W001BJ10 types

Double acting, 3 positions, A and B partially to tank in neutral position

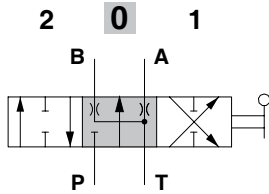

Stroke

position 1: + 6 mm (+0.236 in)
position 2: - 6 mm (-0.236 in)

W001BK10 type

Double acting, 3 positions, A partially to tank and B closed in neutral position

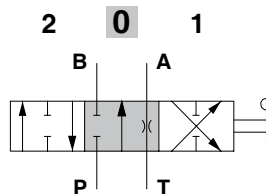

Stroke

position 1: + 6 mm (+0.236 in)
position 2: - 6 mm (-0.236 in)

W001BY10 type

Double acting, 3 positions, B partially to tank and A closed in neutral position

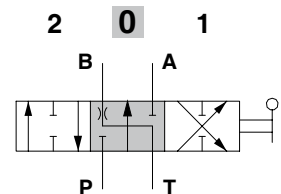

Stroke

position 1: + 6 mm (+0.236 in)
position 2: - 6 mm (-0.236 in)

Spools end kit

Spool end for hydraulic controls

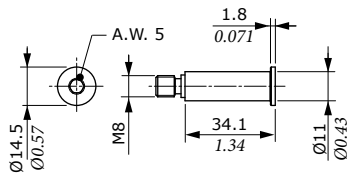
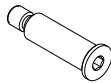

Spool end for electrohydraulic controls

Standard type

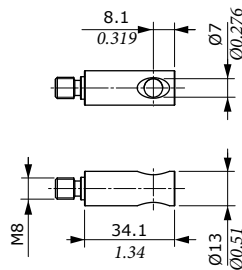
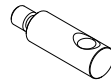

Milled type

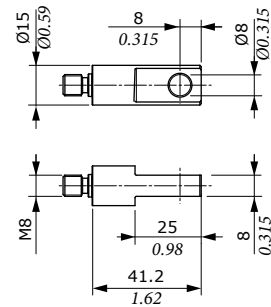
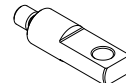

Spool position sensors

SPSL sensor

The SPSL position sensor converts the spool movements into a voltage linear signal.

Working conditions		
Voltage supply		5 VDC
Current absorption		< 10 mA (no load)
Mechanical life		3x10 ⁶
Connector type		DT04-4P Deutsch
Weather protection		IP67 / IP69K
Working temperature		from -40°C to 105°C (from -40°F to 221°F)
Working pressure		350 bar (5100 psi)
Max. electrical stroke		±10 mm (±0.39 in)
Max. mechanical stroke		±10 mm (±0.39 in)
Output signal	range	from 0.5 to 4.5 V
	linearity	± 5%
	spool in neutral	2.5 ± 0.2 V
	max. current	1 mA
EMC compatibility		ISO 13766 / ISO 14982
Mechanical vibrations, shock, bumps		IEC 68-2-6,-27,-29

SPSL sensor output signal

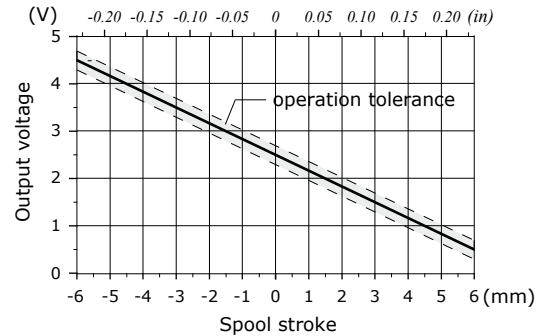

Deutsch DT04-4P connector

Pin	Function
1	+ 5V
2	not connected
3	GND
4	signal OUT

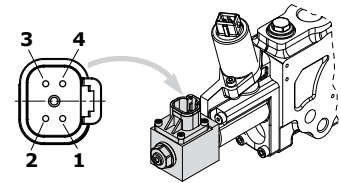

Deutsch DT06-4S mating connector, code 5CON140072

SPSD sensor

The SPSP position sensor converts the spool movements into an electric digital signal.

Working conditions		
Voltage supply		from 9 to 32 VDC
Current absorption		< 10 mA (no load)
Mechanical life		3x10 ⁶
Connector type		DT04-4P Deutsch
Weather protection		IP67 / IP69K
Working temperature		from -40°C to 105°C (from -40°F to 221°F)
Working pressure		350 bar (5100 psi)
Max. electrical stroke		±10 mm (±0.39 in)
Max. mechanical stroke		±10 mm (±0.39 in)
Output signal	type	PNP
	max. current	6 mA
EMC compatibility		ISO 13766 / ISO 14982
Mechanical vibrations, shock, bumps		IEC 68-2-6,-27,-29

SPSD sensor output signal

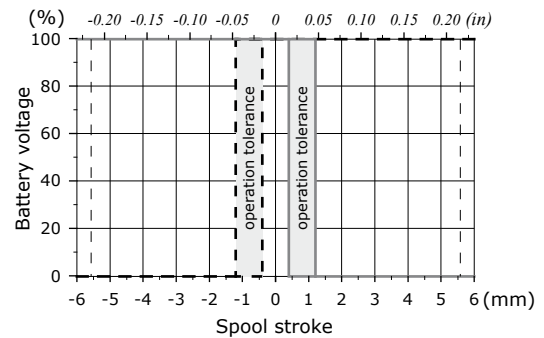

Deutsch DT04-4P connector

Pin	Function
1	Out A
2	GND
3	VB +
4	Out B

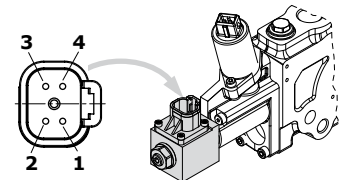

Deutsch DT06-4S mating connector, code 5CON140072

A side controls

H001 type
Lever box

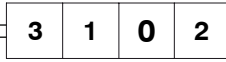
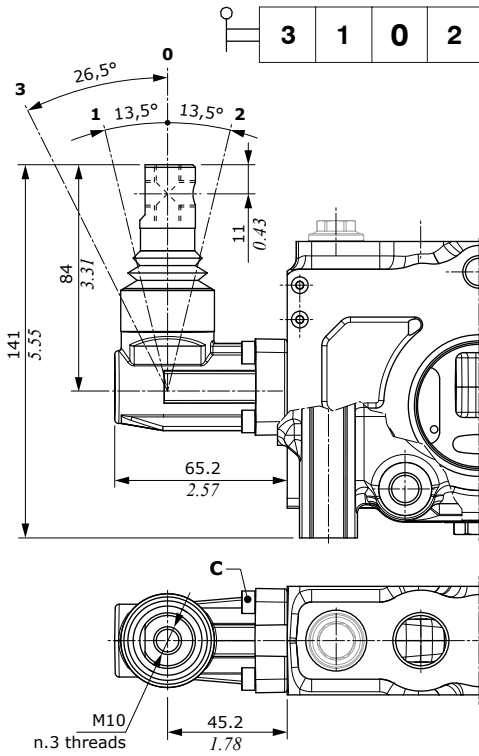

H002 type

Lever box assembled rotated 180°. Dimensions are the same of H001 type

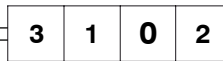
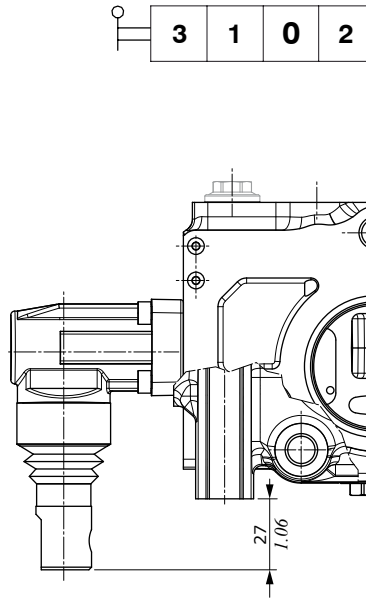

H004 type

With dust proof rubber bellow

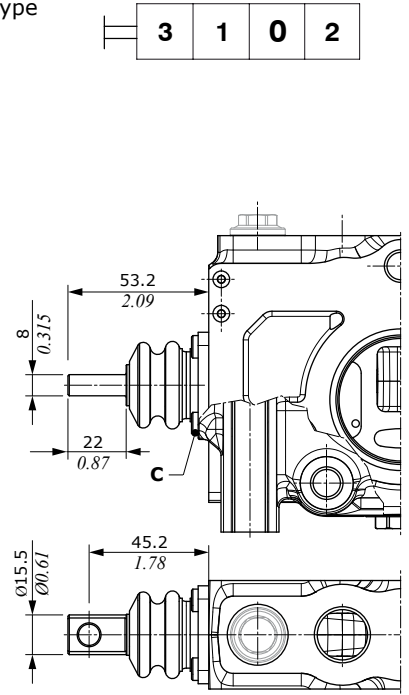

Joystick controls

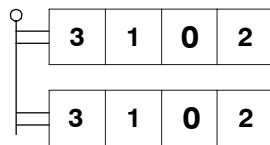

Wrenches and tightening torques

- C = allen wrench 4 - 5/7 Nm (3.7/5.2 lbf_t)
- D = wrench 10
- E = wrench 6
- F = wrench 13 - 7 Nm (5.2 lbf_t)
- G = allen wrench 6 - 7 Nm (5.2 lbf_t)

Configuration examples

Optional rubber bellows
code: 423403065

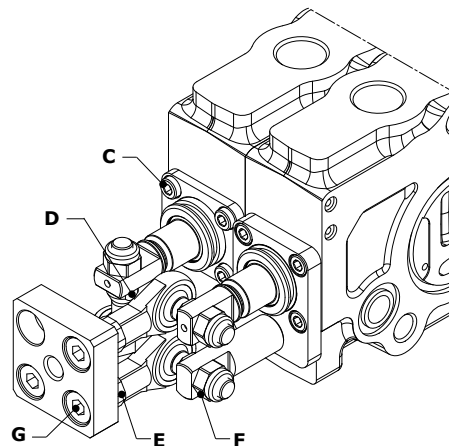
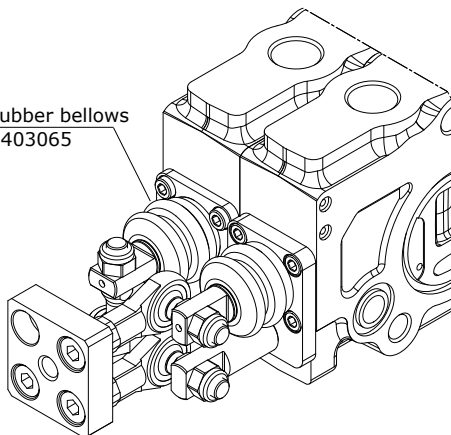

Mechanical controls

A side controls

Joystick controls

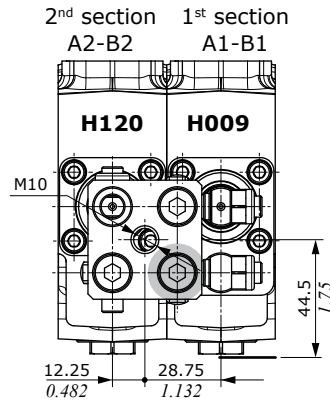
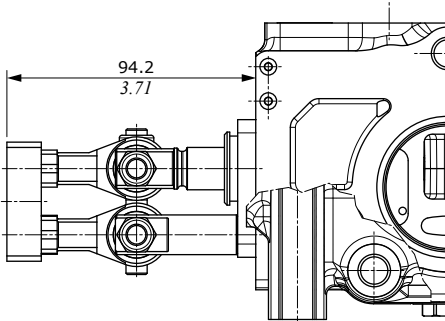

**Right Inlet configuration
H009-H120 type**
pivot "●" on 1st section

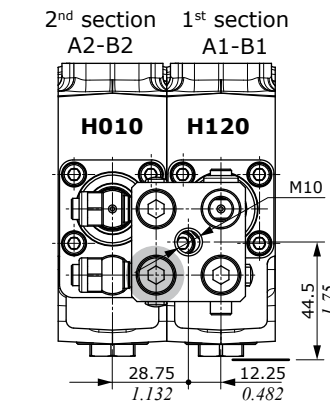
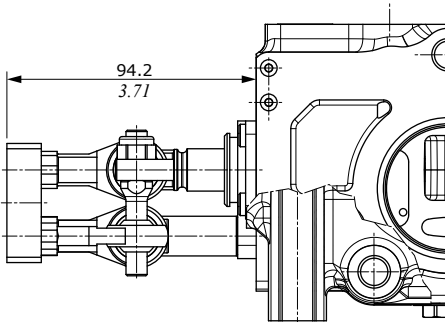
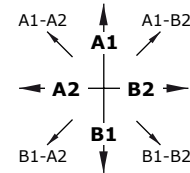

**Right Inlet configuration
H120-H010 type**
pivot "●" on 2nd section

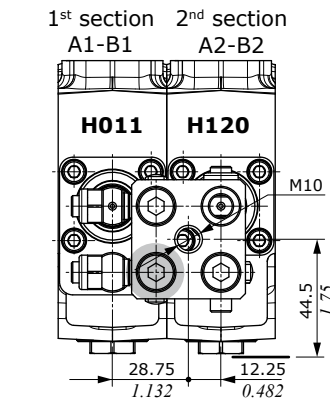
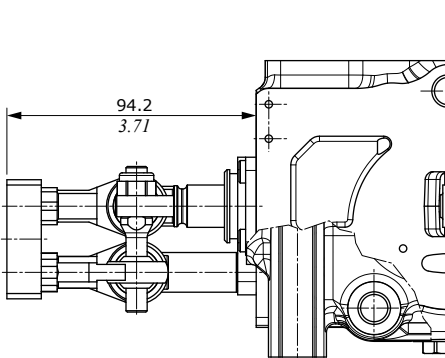
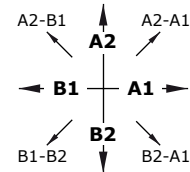

**Left Inlet configuration
H011-H120 type**
pivot "●" on 1st section

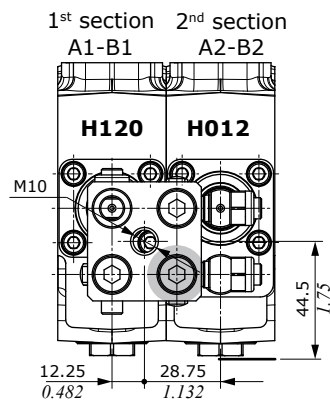
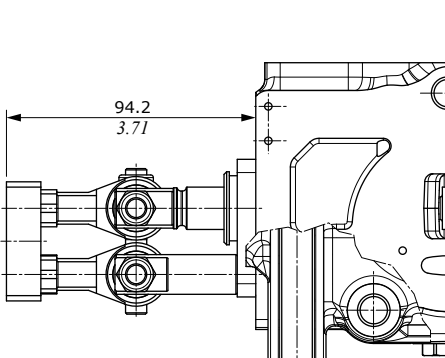
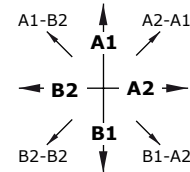

**Left Inlet configuration
H120-H012 type**
pivot "●" on 2nd section

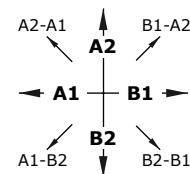

B side controls

With spring return in neutral position

F001A-F001B-F001C types

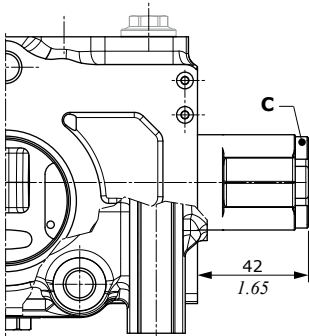
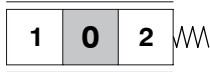

F001ASL - F001ASD types

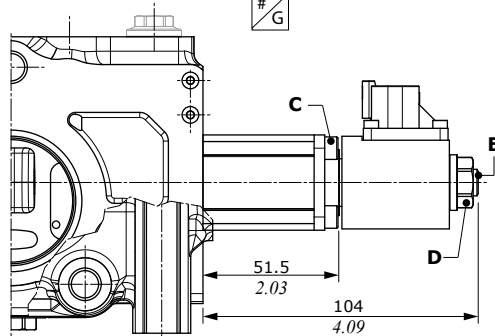
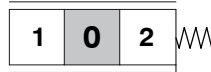

F013A type
M8 male external pin

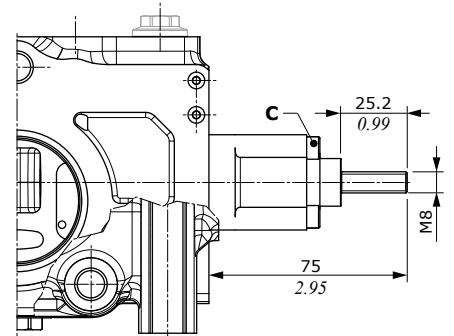
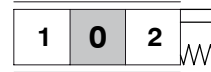

Wrenches and tightening torques
 C = allen wrench 4 - 5/7 Nm (3.7/5.2 lbft)
 D = wrench 17 - 9,8 Nm (7.2 lbft)
 E = allen wrench 4 - 9,8 Nm (7.2 lbft)

Force vs. Stroke diagram

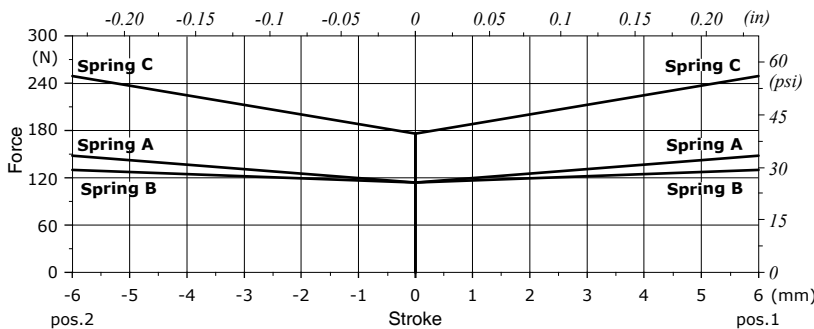

Legenda
 Spring A = from 114 N to 148 N (25.6 lb to 33.3 lb)
 Spring B = from 114 N to 130 N (25.6 lb to 29.2 lb)
 Spring C = from 176 N to 249 N (39.6 lb to 56 lb)

With detent and spring return in neutral position

F002A type
detent in A and B

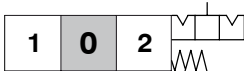

F003A type
detent in A

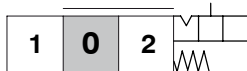

F004A type
detent in B

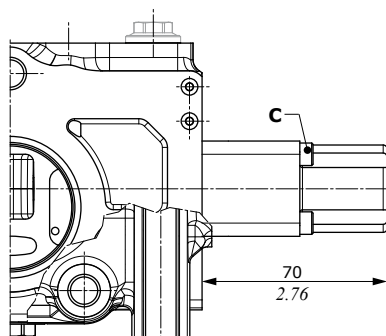

F005A type
4 position, detent in position 3,
W012A spool is required

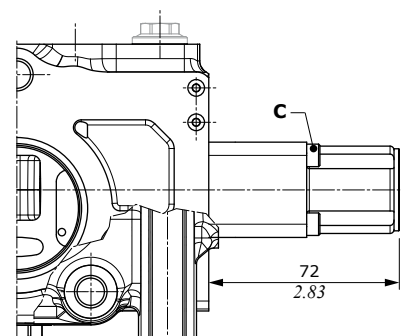

Proportional electrohydraulic controls

Performance data

Following specifications are measured with:

- mineral oil of 46 mm²/s (46 cSt) viscosity at 40°C (104°F) temperature.
- standard spools, connecting P⇒A⇒B⇒T ports without flow multiplication
- 12 VDC and 24 VDC nominal voltage with ± 10% tolerance.

The following electrohydraulic controls need a CED400W electronic unit; for information, please contact our Sales Department.

A and B sides spool controls

Electric specifications

Coil impedance	12 VDC	4.7 Ω
	24 VDC	20.8 Ω
Max. operating current	12 VDC	1.5 A
	24 VDC	0.75 A
No load current consumption		0
Min. flow control signal	12 VDC	400 mA
	24 VDC	200 mA
Flow control signal	12 VDC	1200 mA
	24 VDC	600 mA
Dither frequency		70 - 90 Hz
Insertion		100%
Coil insulation		Class H (180°C - 356°F)
Connector type		AMP JPT Deutsch DT
Weather protection (connector)		IP65 (JPT type) IP69K (DT type)

Hydraulic specifications

Max. pressure	40 bar (580 psi)
Max. back pressure on solenoid valve drain	5 bar (72.5 psi)

Performance data

Solenoid pressure reducing valve performance

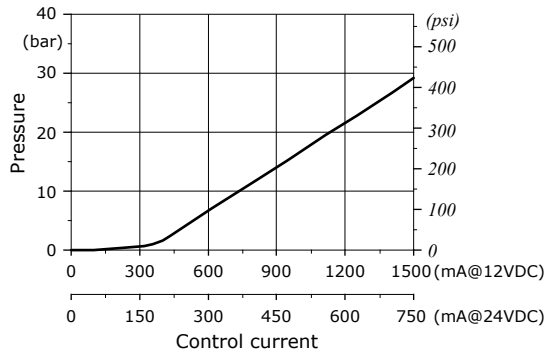

Stroke vs. Current diagram

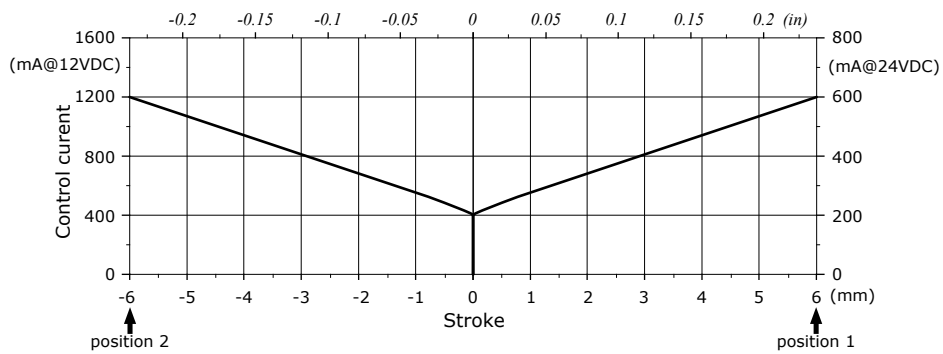

Stroke vs. Pressure diagram

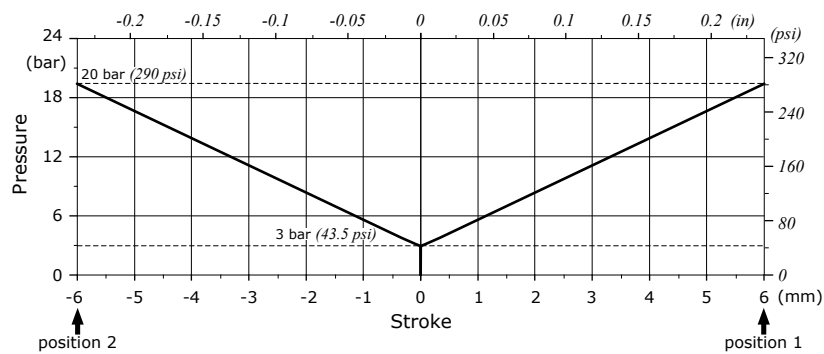

Proportional electrohydraulic controls

A side controls

HP07 type

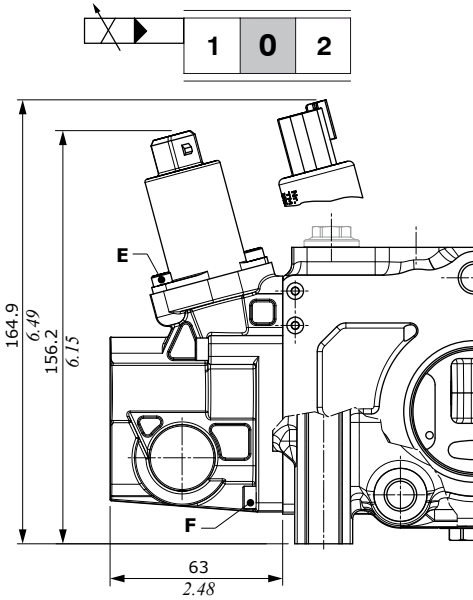

HP07L type
with spool stroke limiter on B port

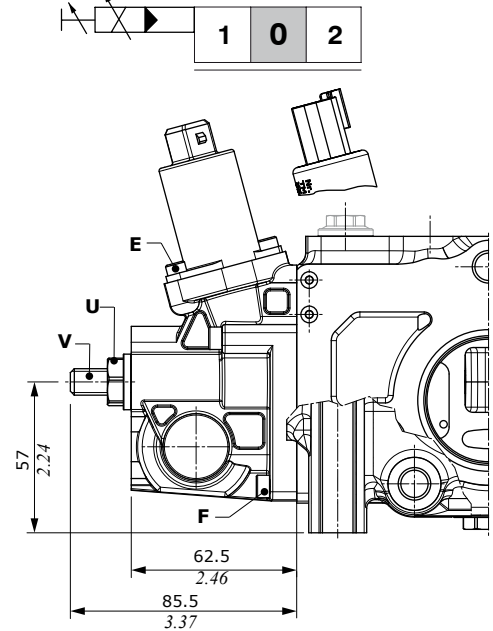

HP04 type
with lever

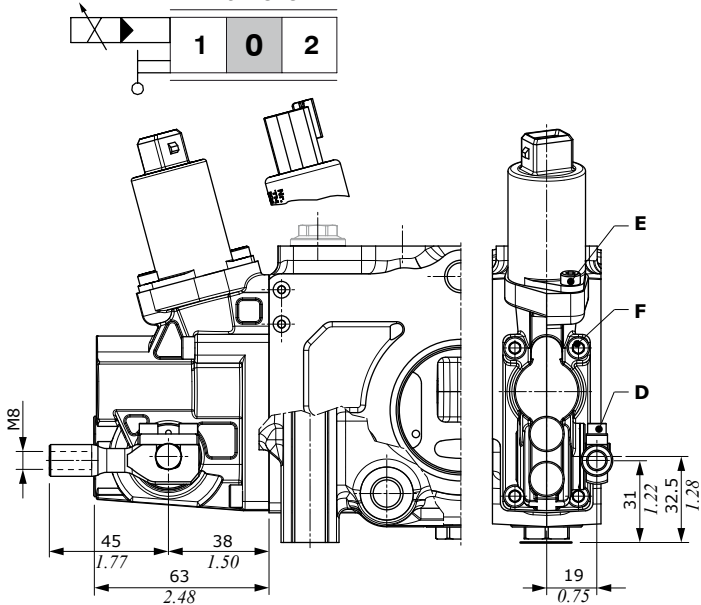

HP04L type
with spool stroke limiter on A and B ports

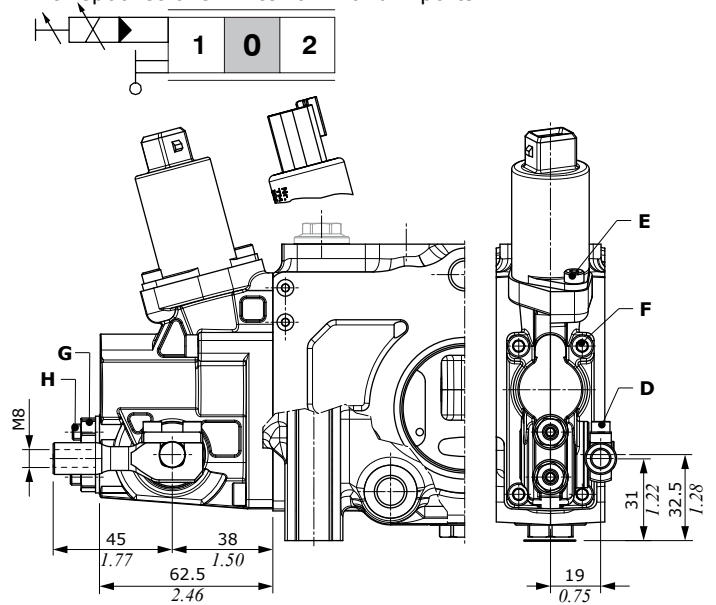

Wrenches and tightening torques

- D = allen wrench 3 - 2 Nm (1.5 lbf^t)
- E = allen wrench 3 - 2 Nm (1.5 lbf^t)
- F = allen wrench 4 - 5/7 Nm (3.7/5.2 lbf^t)
- G = wrench 10 - 15 Nm (11 lbf^t)
- H = allen wrench 3
- U = wrench 17 - 24 Nm (11 lbf^t)
- V = allen wrench 5

Proportional electrohydraulic controls

B side controls

FP04 type

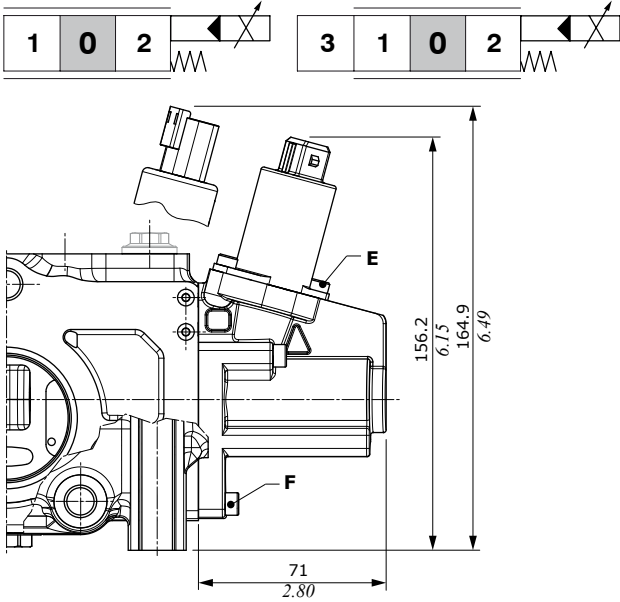

FP04L type
with spool stroke limiter on A port

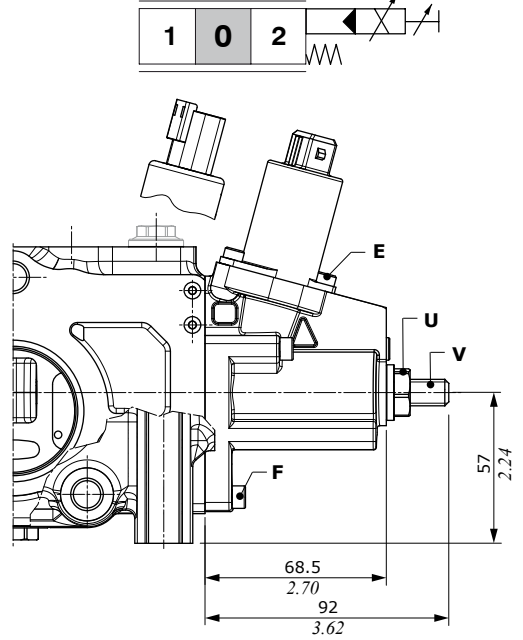

FP04SL - FP04SD type
with spool position sensor

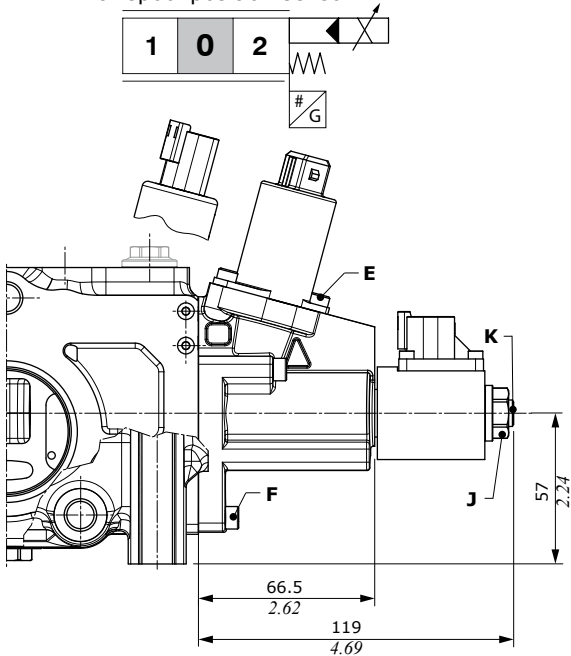

Wrenches and tightening torques

- E = allen wrench 3 - 2 Nm (1.5 lbf^t)
- F = allen wrench 4 - 5/7 Nm (3.7/5.2 lbf^t)
- J = wrench 17 - 9.8 Nm (7.2 lbf^t)
- K = allen wrench 4 - 9.8 Nm (7.2 lbf^t)
- U = wrench 17 - 24 Nm (11 lbf^t)
- V = allen wrench 5

Proportional hydraulic controls

A and B side s controls

Controls are available with upper or side ports and with spool stroke limiter.

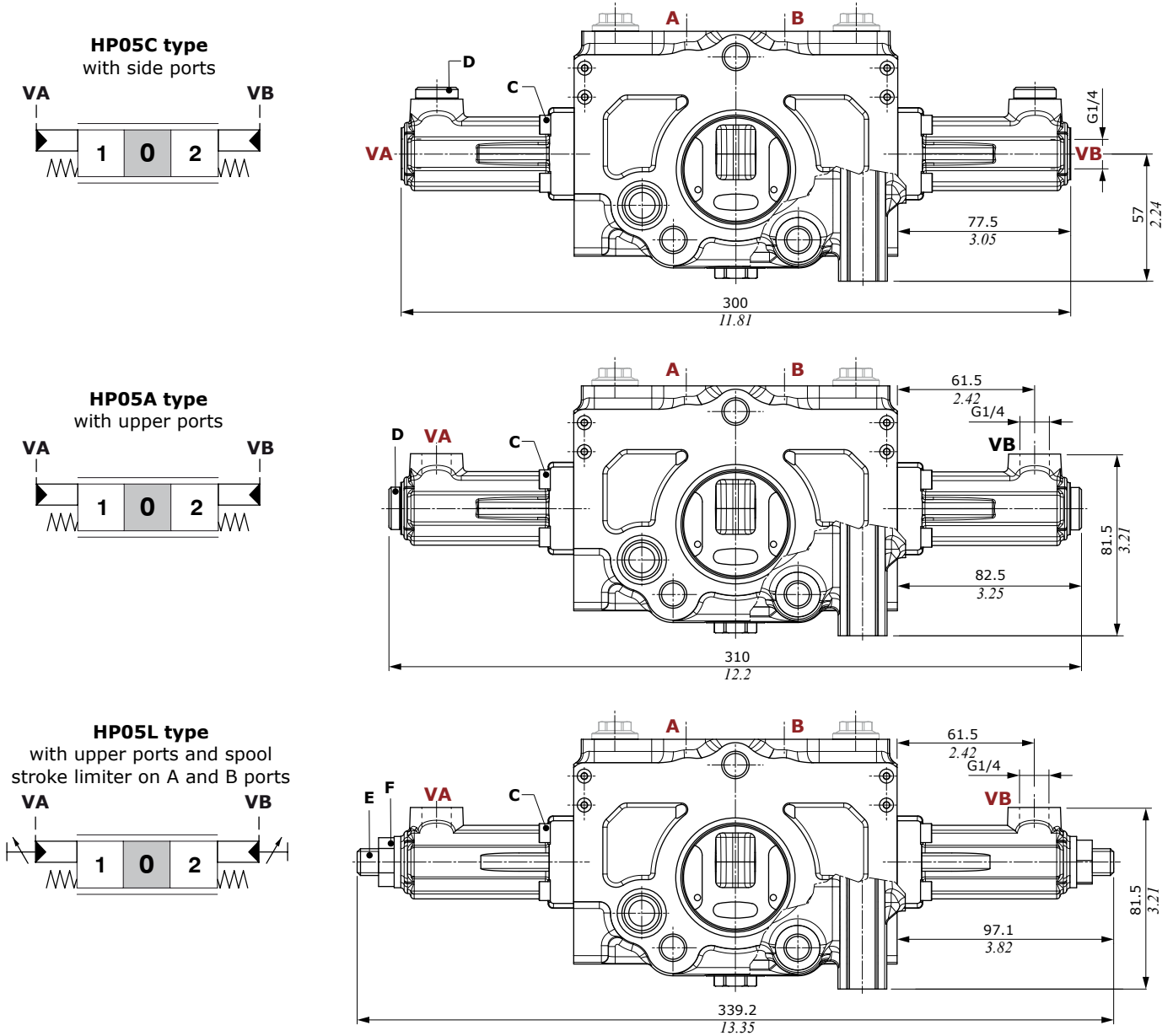

Stroke vs. Pressure diagram

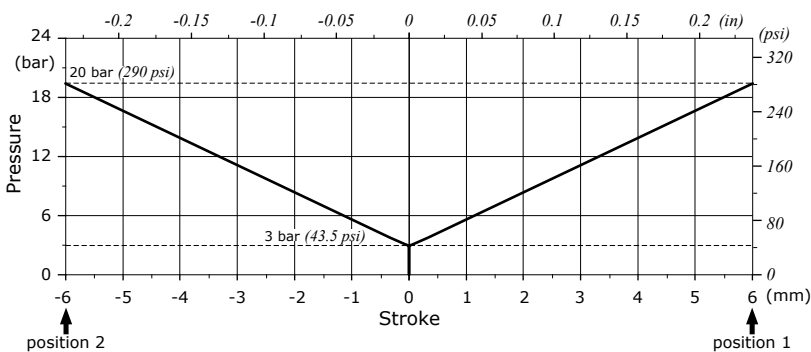

Wrenches and tightening torques

- C = allen wrench 4 - 5/7 Nm (3.7/5.2 lbft)
- D = allen wrench 6 - 30 Nm (22 lbft)
- E = allen wrench 6
- F = wrench 19 - 15 Nm (11 lbft)

Wrenches and tightening torques

C = wrench 13 - 40 Nm (29.5 lbf_t)

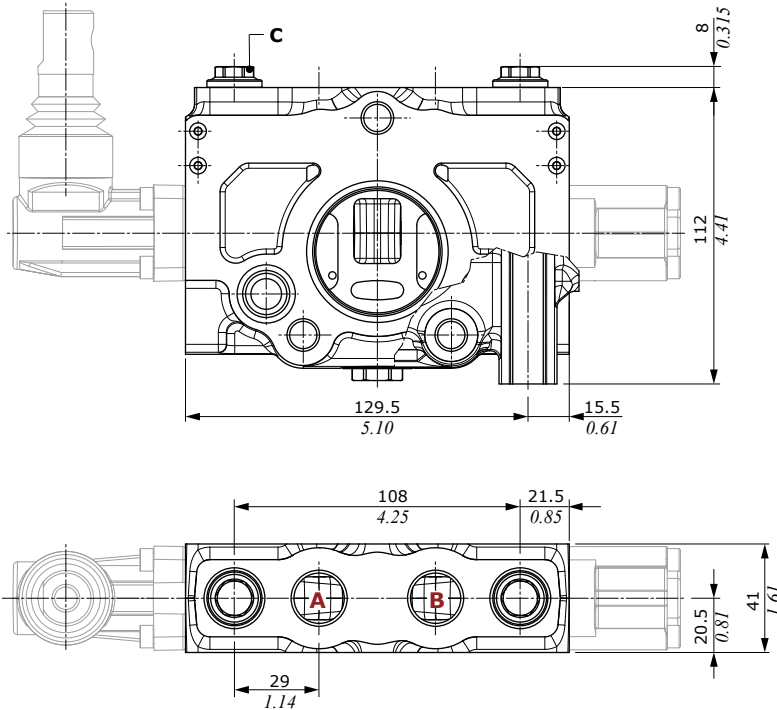

03TF type

combined antishock and anticavitation valve, with fixed setting



02TF type

anticavitation valve



05TF type

valve blanking plug



03TF type: combined valves

Setting example

@10 l/min (2.6 US gpm)

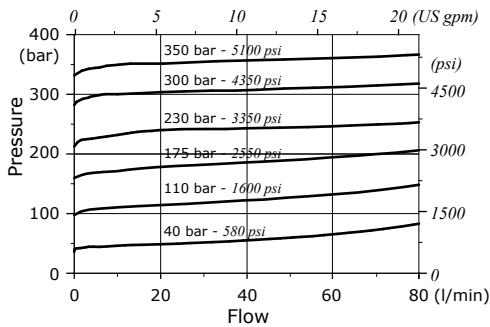

Pressure drops

(in anticavitation)

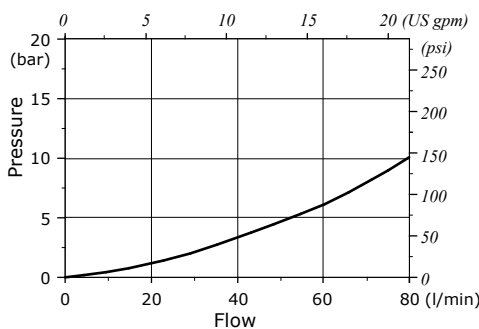

02TF type: anticavitation valve

Pressure drops

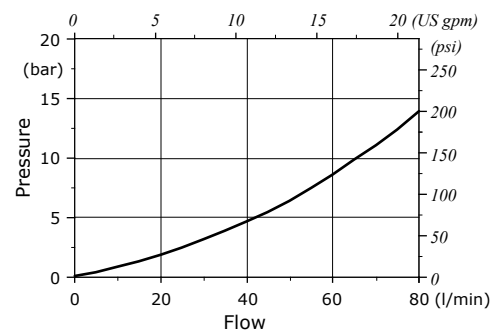

Dimensional data and hydraulic circuit

KZM configuration

For mechanical, hydraulic and electrohydraulic controls, without pressure reducing valve.

KZM2 type: outlet port plugged, Y pilot and X drain plugged

Wrenches and tightening torques

C = allen wrench 6 - 40 Nm (29.5 lbf^t)

D = allen wrench 6 - 30 Nm (22 lbf^t)

E = allen wrench 12 - 90 Nm (66 lbf^t)

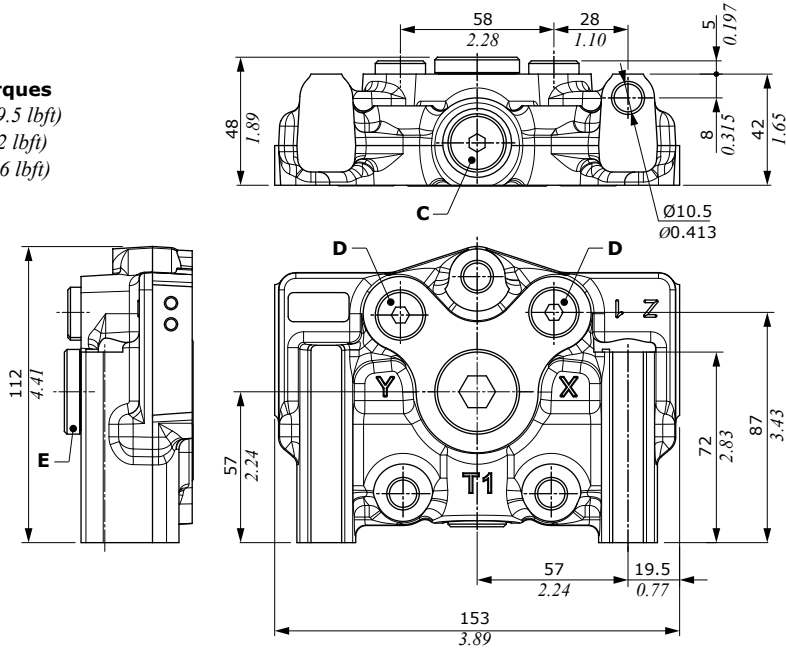

Right Inlet circuit

Left Inlet circuit

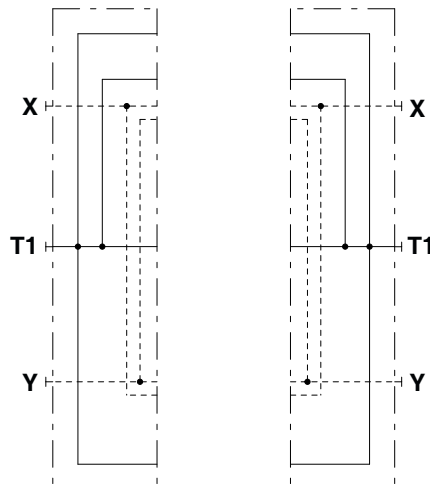

Dimensional data and hydraulic circuit

KZM configuration

KZMH1 type: with HPCO carry over on T1 port, Y pilot and X drain plugged

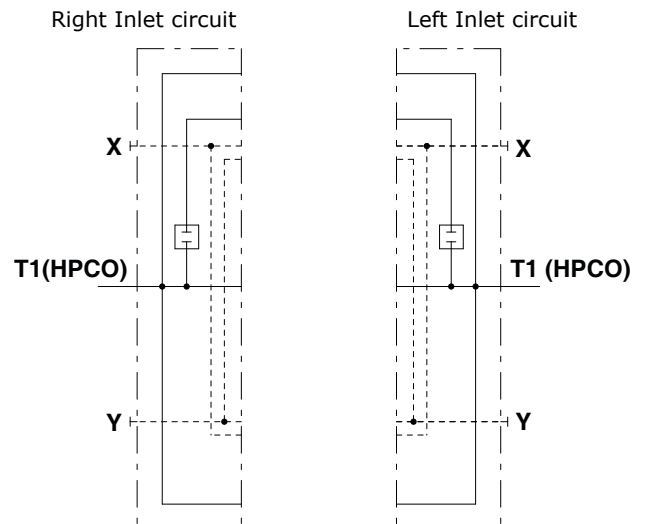
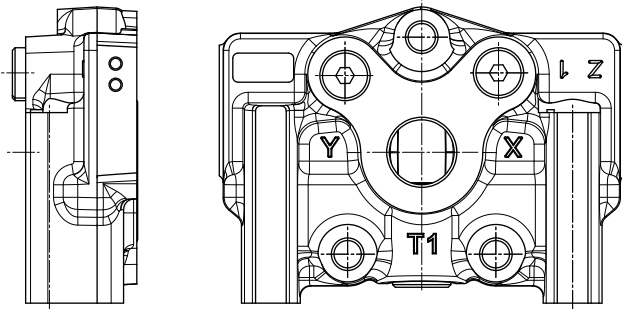

Port configuration

Type	T1 port	X drain	Y pilot	
KZM1	open	plugged	plugged	
KZM2	plugged	plugged	plugged	
KZM3	open	open	open	
KZM4	plugged	open	open	
KZMH1	HPCO open	plugged	plugged	
KZMH2	HPCO open	open	open	

Dimensional data and hydraulic circuit

KZP configuration

For mechanical, hydraulic and electrohydraulic controls, with pressure reducing valve and backpressure valve.

Type KZP3

ports plugged, pilot Y plugged, X drain open

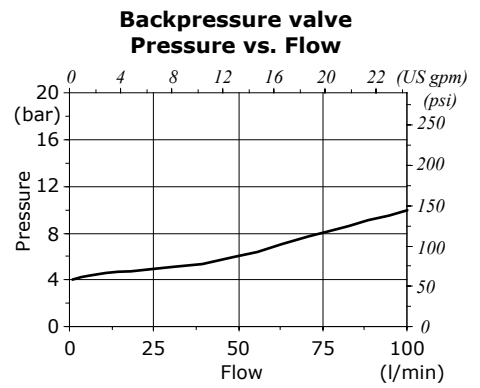
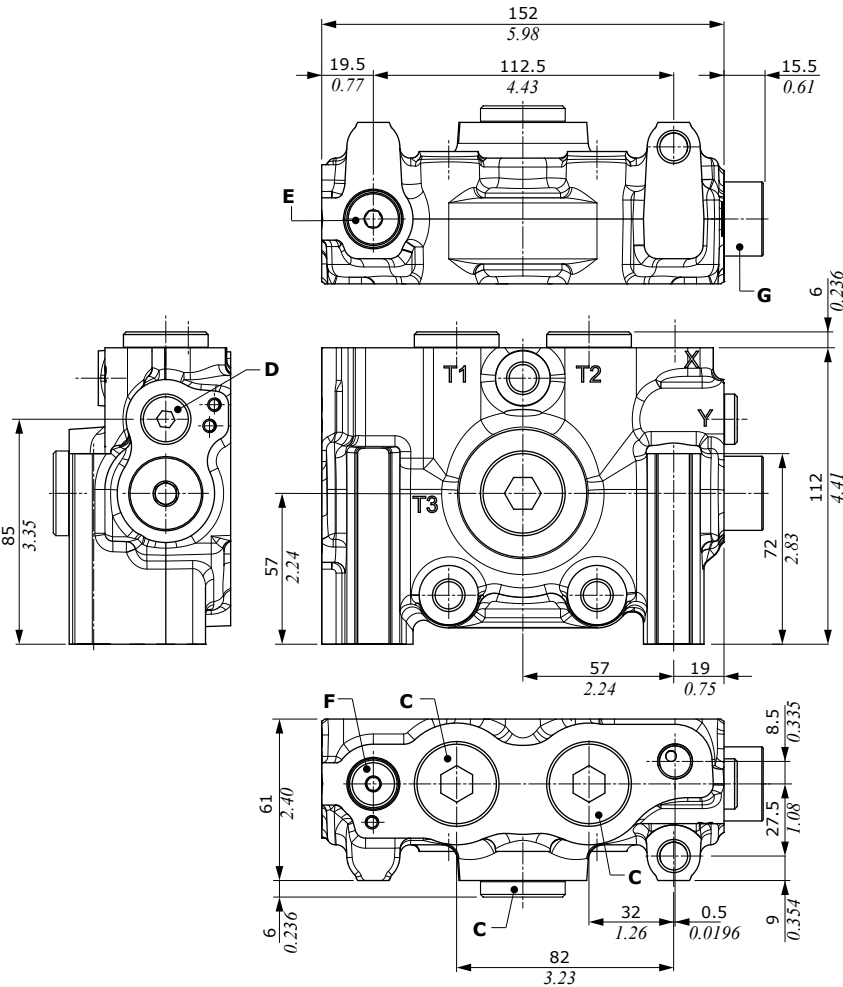

Wrenches and tightening torques

- C = allen wrench 12 - 90 Nm (66 lbft)
- D = allen wrench 6 - 30 Nm (22 lbft)
- E = allen wrench 6 - 30/35 Nm (22/25.8 lbft)
- F = allen wrench 5 - 20/25 Nm (14.8/34 lbft)
- G = allen wrench 8 - 50 Nm (37 lbft)

Right Inlet circuit

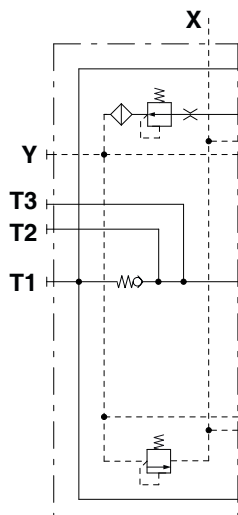

Left Inlet circuit

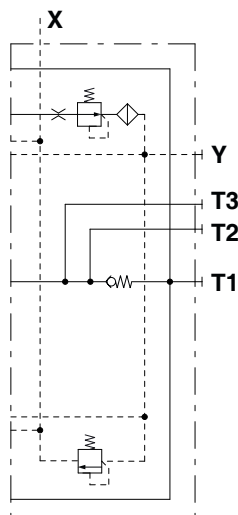

Dimensional data and hydraulic circuit

KZP configuration

KZPH1 type

HPCO on T2 port, T1 port and X drain open, T3 port and Y pilot closed, without backpressure valve

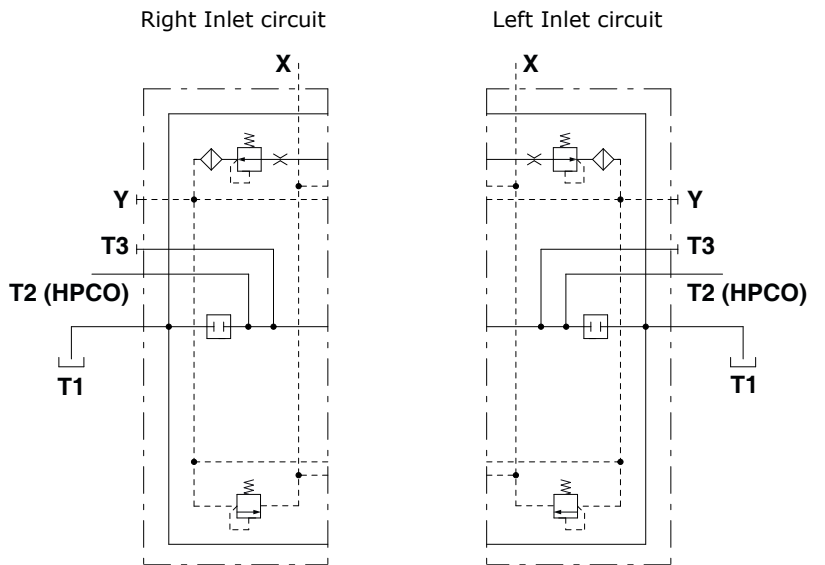
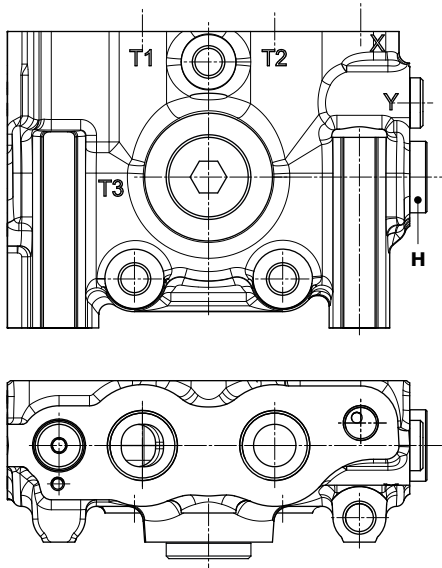

Wrenches and tightening torques

H = allen wrench 8 - 50 Nm (37 lbf)

Port configuration

Type	T1 port	T2 port	T3 port	X drain	Y pilot	Backpressure valve	
KZP1	open	plugged	plugged	open	plugged	yes	
KZP3	plugged	plugged	plugged	open	plugged	yes	
KZP6	plugged	plugged	open	open	plugged	no	
KZPH1	open	HPCO open	plugged	open	plugged	no	
KZPH2	open	plugged	HPCO open	open	plugged	no	

Dimensional data and hydraulic circuit

Configuration with electrohydraulic controls.

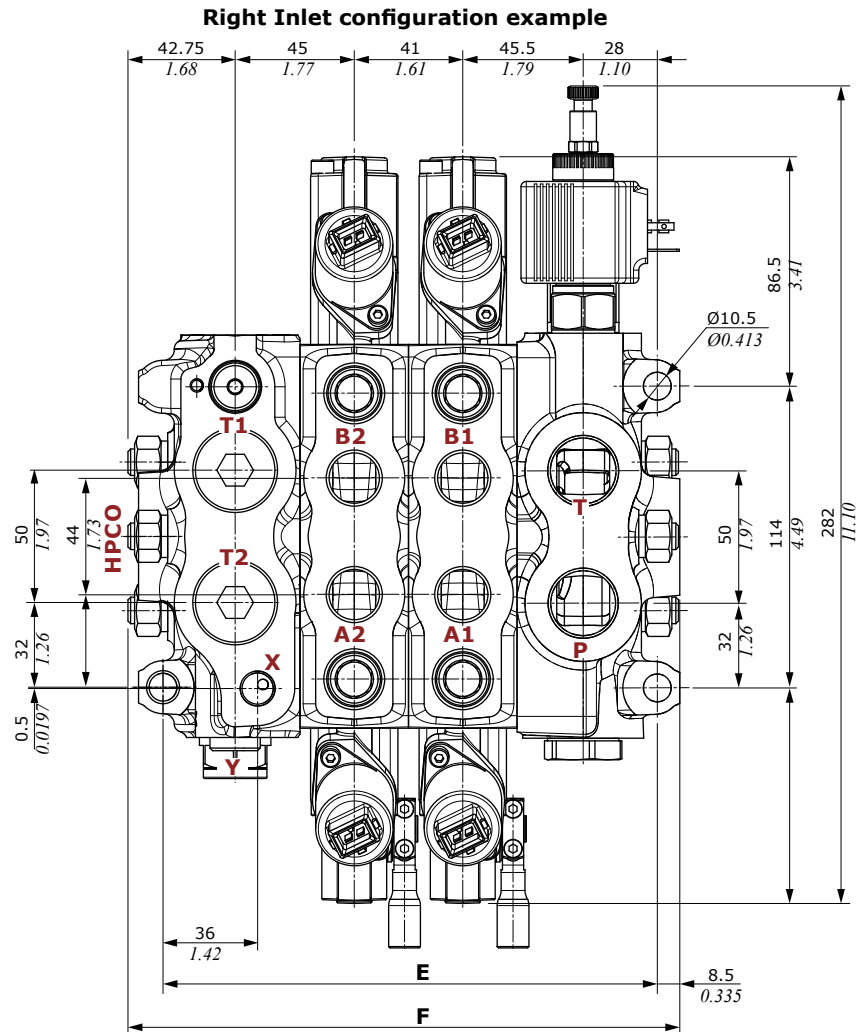
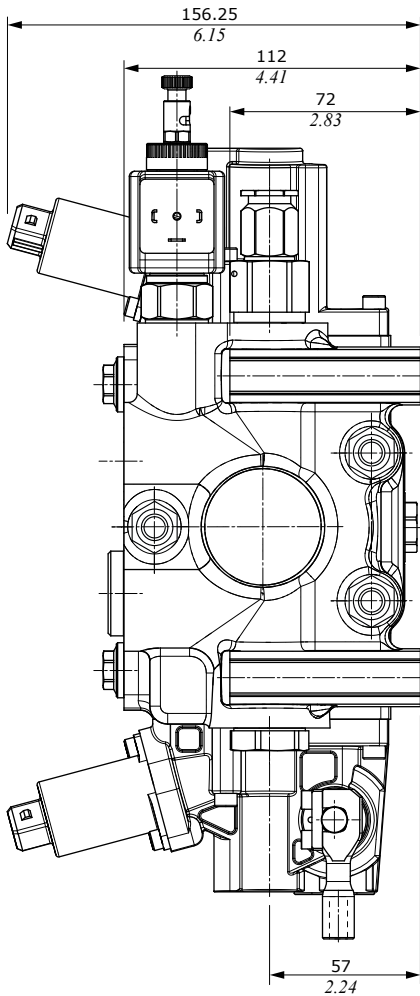

Left Inlet configuration example

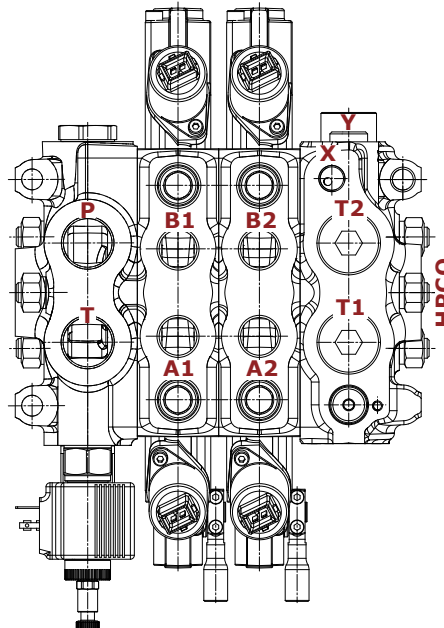

TYPE	E		F	
	mm	in	mm	in
DVS14/1	144	5.67	173.25	6.82
DVS14/2	185	7.28	214.25	8.44
DVS14/3	226	8.90	255.25	10.05
DVS14/4	267	10.51	296.25	11.66
DVS14/5	308	12.13	337.25	13.28
DVS14/6	349	13.74	378.25	14.89
DVS14/7	390	15.35	419.25	16.51
DVS14/8	431	16.97	460.25	18.12
DVS14/9	472	18.58	501.25	19.73
DVS14/10	513	20.20	542.25	21.35

NOTE: Drawings and dimensions are referred to a **BSP** threading configuration.

Dimensional data and hydraulic circuit

The DVS14 sectional valve is available in Flow Unloader configuration as well.

Feature of this configuration is to limit flow on "free flow line" (typically 20 l/min - 5.3 US gpm) making it possible to manage all flow (80 l/min - 21 US gpm) by working ports, when the spools are operated till to stroke end.

The Flow Unloader system is configured with special inlet section, fitted with compensator and dedicated spools.

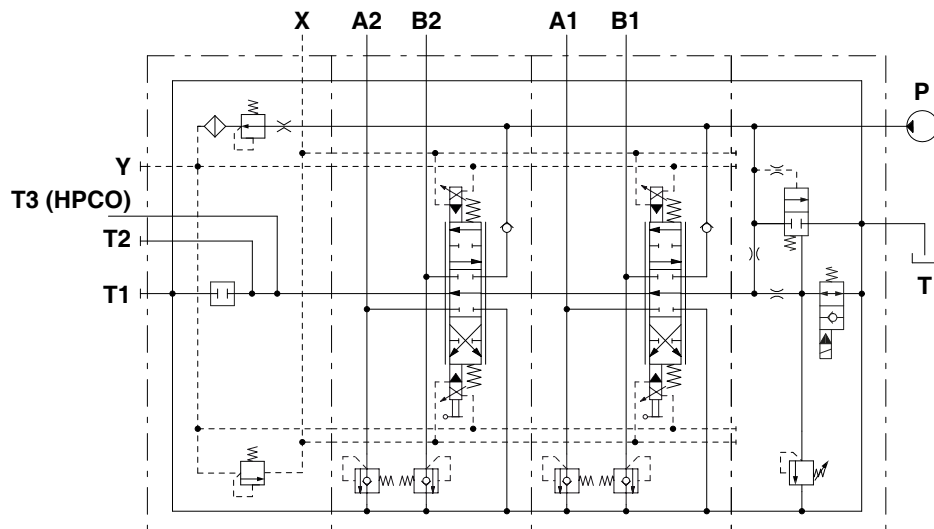

Right Inlet valvet with electrohydraulic controls configuration:

DVS14/2/MRQ-V1A(200)V7B-C12DI-E-MA-X-G05/W001Q-HP04-FP04-B12AJ-RP1-G04.03TF-PA(100)\03TF-PB(100)/W001Q-HP04-FP04-B12AJ-RP1-G04.03TF-PA(100)\03TF-PB(100)/KZPH4-G05

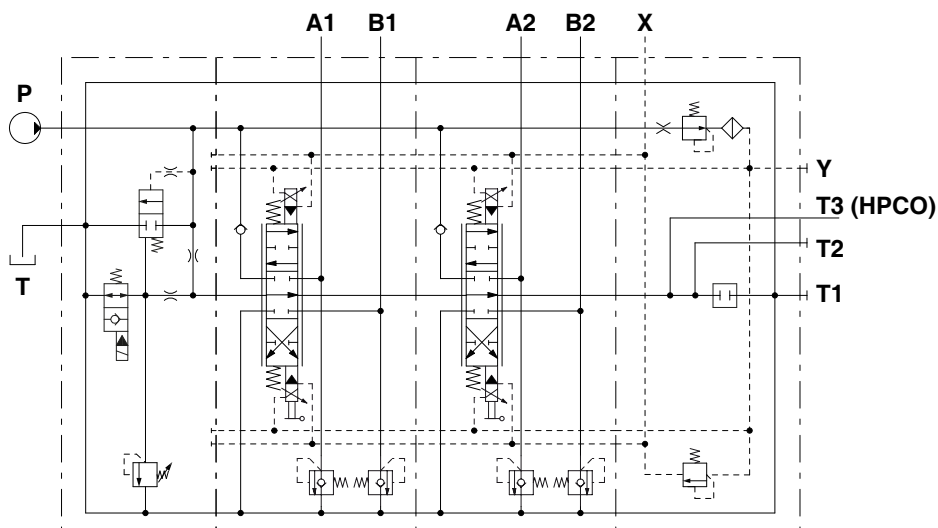

Left Inlet valvet with electrohydraulic controls configuration:

DVS14/2/MLQ-V1A(200)V7B-C12DI-E-MA-X-G05/W001Q-HP04-FP04-B12AJ-RP1-G04.03TF-PA(100)\03TF-PB(100)/W001Q-HP04-FP04-B12AJ-RP1-G04.03TF-PA(100)\03TF-PB(100)/KZPH4-G05

Part ordering codes

Right Inlet: **R**
Left inlet: **L**

valve position valve position T port open

DVS14/2/MLQ - V1 A (200) V7 B - C12DI - E - MA - X - G05 / W001Q-HP04-FP04-B12AJ-RP1-G04.02TF-

1 2 2 3 4 5 6 1 7

valve in position A valve in position B

A **B**

PA\02TF-PB/W001Q-HP04-FP04-B12AJ-RP1-G04.02TF-PA\02TF-PB/KZPH4-G05-<P006/2>

7 **C**

B

Valve is painted as std, with one coat of Primer RAL9005 black antitrust paint

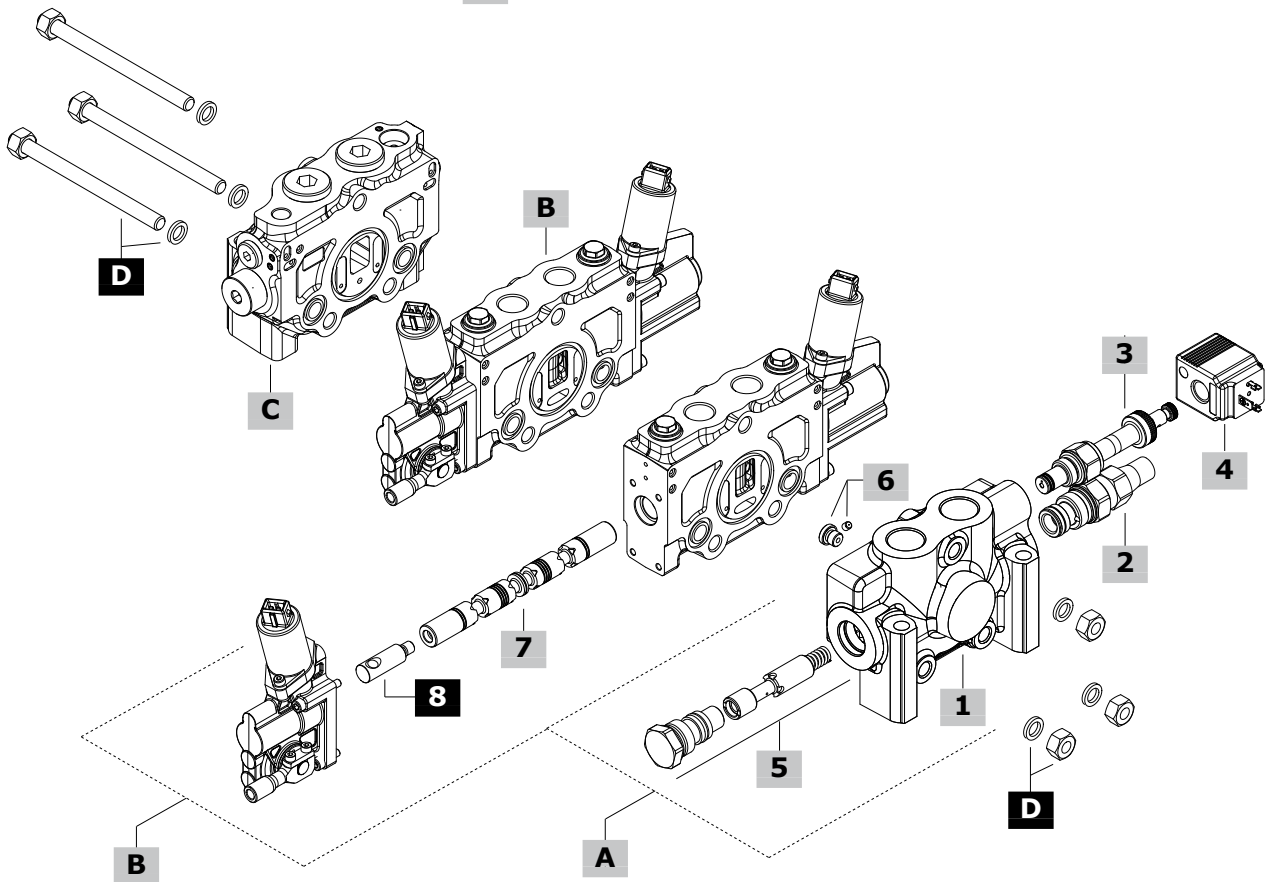

Part ordering codes

A Complete inlet section * page 38

TYPE: **MLQ-V1A(200)-V7B-C12DI-E-MA-X-G05**
 CODE: SHE140004
 DESCRIPTION: With compensator, upper outlet and inlet ports, direct operated main pressure relief valve, 12VDC solenoid operated unloading valve (DIN connector)

B Complete working section * page 14

Right Inlet configuration

TYPE: **SD\W001Q-HP04-FP04-B12AJ-RP1-G04.05TF-PA/05TF-PB**
 CODE: SHL140013

DESCRIPTION: Parallel circuit with port valves arrangement (seat plugged), 3 positions double acting spool with A and B closed in neutral position, 12VDC proportional electrohydraulic control (AMP JPT connector) with lever and spring return to neutral position

TYPE: **SD\W002Q-HP04-FP04-B12AJ-RP1-G04.05TF-PA/05TF-PB**
 CODE: SHL140014

DESCRIPTION: As previous one, 3 positions double acting spool with A and B to tank in neutral position

Left Inlet configuration

TYPE: **SS\W001Q-HP04-FP04-B12AJ-RP1-G04.05TF-PA/05TF-PB**
 CODE: SHL140011

DESCRIPTION: Parallel circuit with port valves arrangement (seat plugged), 3 positions double acting spool with A and B closed in neutral position, 12VDC proportional electrohydraulic control (AMP JPT connector) with lever and spring return to neutral position

TYPE: **SS\W002Q-HP04-FP04-B12AJ-RP1-G04.05TF-PA/05TF-PB**
 CODE: SHL140012

DESCRIPTION: As previous one, 3 positions double acting spool with A and B to tank in neutral position

1 Inlet section body * page 38

TYPE	CODE	DESCRIPTION
Q-G05	4205C3003	Section body for Flow Unloader configuration, with compensator arrangement, G3/4 ports

2 Main relief valve page 39

TYPE	CODE	DESCRIPTION
V1(100)	91502C302	Direct operated, setting range from 50 to 200 bar (725 to 2900 psi)
V1(250)	91502C301	Direct operated, setting range from 200 to 420 bar (2900 to 6100 psi)
V3	430155001	Valve blanking plug

3 Unloading valve page 39

TYPE	CODE	DESCRIPTION
V8	0EB08002001	Solenoid operated unloading valve (without coil), without emergency actuation
V7	0EB08002000	As previous one with "push&twist" emergency actuation
V3	430059003-H	Valve blanking plug

4 Coils page 44

TYPE	CODE	DESCRIPTION
C12DI	4SLE001200A	BER type, 12 VDC, ISO4400 connector
C12AJ	4SLE001203A	BER type, 12 VDC, AMP JPT connector
C12DE	4SLE001202A	BER type, 12 VDC, Deutsch connector

For complete available coil code list see page 45

C Complete outlet section * page 41

TYPE	CODE	DESCRIPTION
For electrohydraulic controls, with pressure reducing valve		
KZP2-G05	SHU140013	Without backpressure valve, upper T1 port and X drain open, T2-T3 outlets and Y pilot plugged
KZP4-G05	SHU140014	Without backpressure valve, X drain open, other ports plugged
KZP6-G05	SHU140021	Without backpressure valve, upper T1-T2 ports and Y pilot plugged, side T3 port and X drain open
KZPH3-G05	SHU140003	Without backpressure valve, carry-over (HPCO) on upper T2 port, upper T1 and side T3 ports plugged, X drain open, Y pilot plugged
KZPH4-G05	SHU140004	Without backpressure valve, carry-over (HPCO) on side T3 port, upper T1 and T2 ports plugged, drain X open, Y pilot plugged

D Tie rods kit

CODE	DESCRIPTION
5TIRDVS1401EI	For 1 section valve
5TIRDVS1402EI	For 2 sections valve
5TIRDVS1403EI	For 3 sections valve
5TIRDVS1404EI	For 4 sections valve
5TIRDVS1405EI	For 5 sections valve
5TIRDVS1406EI	For 6 sections valve
5TIRDVS1407EI	For 7 sections valve
5TIRDVS1408EI	For 8 sections valve
5TIRDVS1409EI	For 9 sections valve
5TIRDVS1410EI	For 10 sections valve

5 Compensator page 40

TYPE	CODE	DESCRIPTION
MA	4300C3017	Compensator kit for Flow Unloader section, spring A type

6 Tappi con fori calibrati

TYPE	CODE	DESCRIPTION
	423411308	M5 screw with $\varnothing 0.6$ mm ($\varnothing 0.0236$ in) tapered hole: nr.1 always present
G1/8 plug with tapered hole for compensator flow control.		
X	423400145	$\varnothing 3.5$ mm ($\varnothing 0.138$ in) for 20 l/min (5.3 US gpm) flow
Y	423400142	$\varnothing 4.0$ mm ($\varnothing 0.157$ in) for 28 l/min (7.4 US gpm) flow
Z	423400116	$\varnothing 4.5$ mm ($\varnothing 0.177$ in) for 36 l/min (9.5 US gpm) flow
K	423400191	$\varnothing 5.0$ mm ($\varnothing 0.197$ in) for 44 l/min (11.6 US gpm) flow

7 Spools page 40

TYPE	CODE	DESCRIPTION
Double acting spools		
W001Q	4212C3056	3 positions, A and B closed in neutral position, for 70 l/min (18.5 US gpm)
W002Q	4212C3057	3 positions, A and B to tank in neutral position, for 70 l/min (18.5 US gpm)

8 Spool pin

CODE	DESCRIPTION
422501293	Spool pin for electrohydraulic controls

NOTE (*): Codes are referred to **BSP** thread

Inlet section

Dimensional data and hydraulic circuit

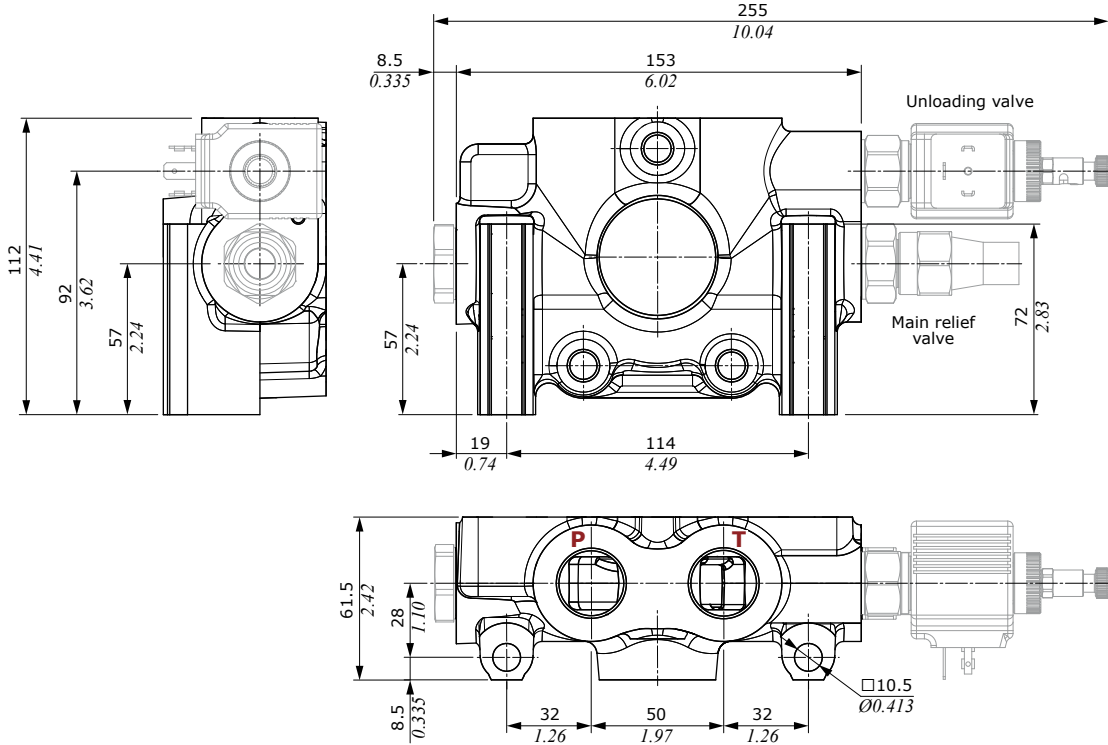

MRQ type
for Right Inlet

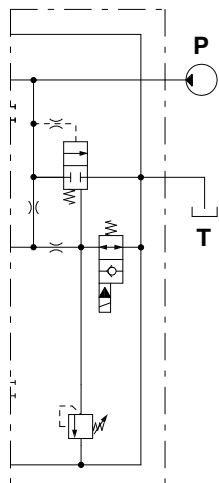

MLQ type
for Left Inlet

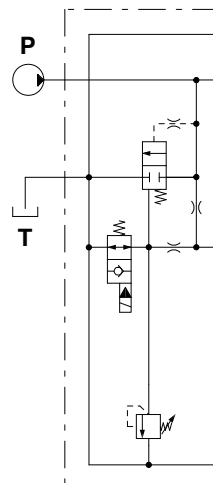

Inlet valves

Main relief valve

**V1 type
Direct operated**

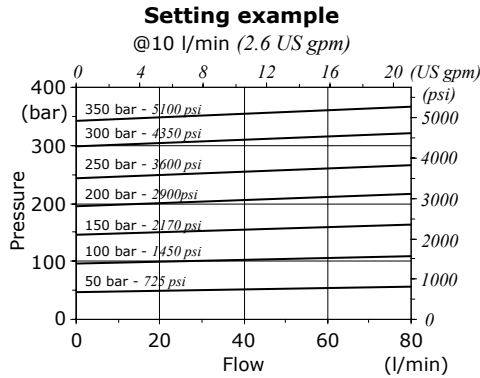
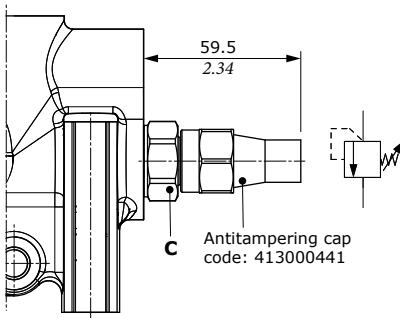

**V3 type
Valve blanking plug**

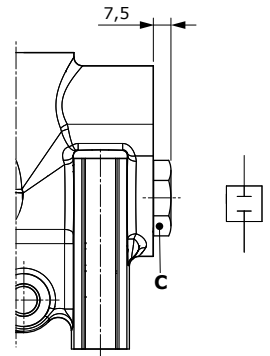

Wrenches and tightening torques

C = wrench 27 - 80 Nm (59 lbft)

Unloading valve

**Tipo V7
Solenoid operated**

With push&twist emergency actuation

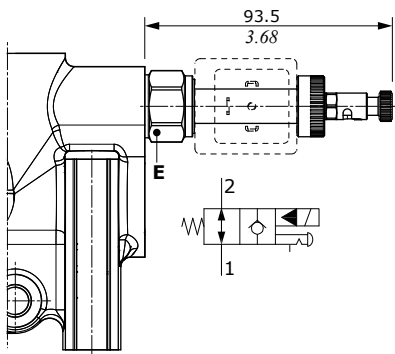

Pressure drops

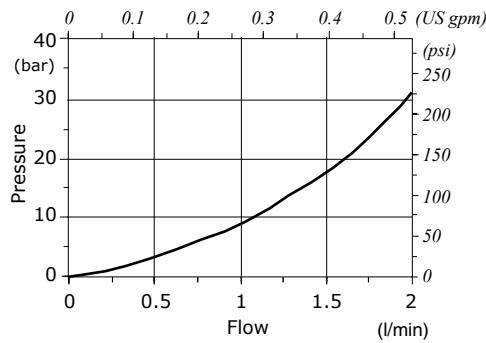

**V3 type
Valve blanking plug**

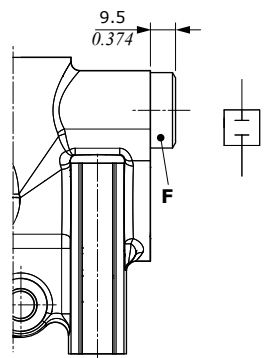

Without emergency actuation

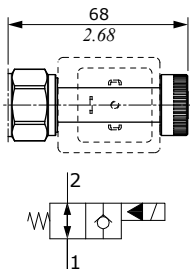

Wrenches and tightening torques

E = wrench 24 - 30 Nm (22 lbft)

F = allen wrench 8 - 30 Nm (22 lbft)

Valve features

Nominal flow : 2 l/min (0.53 US gpm)
 Max. pressure. : 350 bar (5100 psi)
 Max. internal leakage.. : 0.25 cm³/min @ 210 bar
 (0.015 in³/min @ 3050 psi)

For **BER** type coils see page 44

Inlet section

Compensator kit

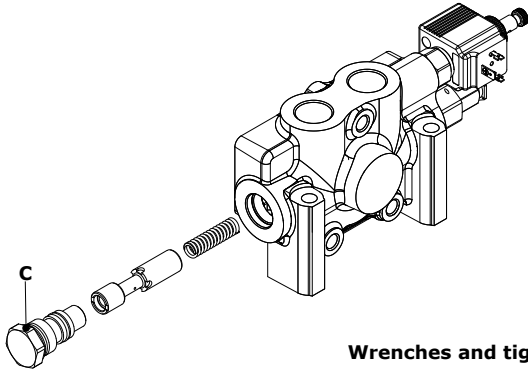

Wrenches and tightening torques
C = wrench 27 - 80 Nm (59 lbf)

P⇒T Pressure drop inlet compensator (margin pressure)

Flow = 80 l/min (21 US gpm)

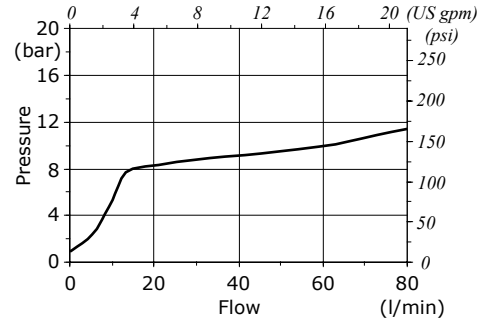

Spools

W001Q type

Double acting, 3 position,
A and B closed in neutral position

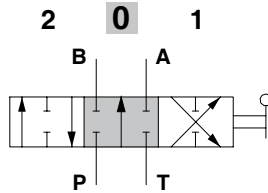
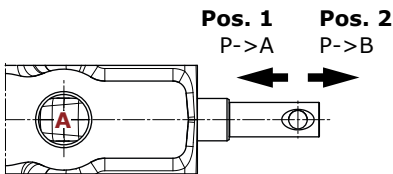

Stroke
position 1: + 6 mm (+0.236 in)
position 2: - 6 mm (-0.236 in)

W002Q type

Double acting, 3 position,
A and B to tank in neutral position

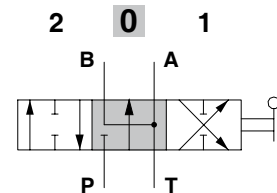

Stroke
position 1: + 6 mm (+0.236 in)
position 2: - 6 mm (-0.236 in)

For section dimensions see pages 32/33.

KZP2 type circuit example

Right Inlet circuit

Left Inlet circuit

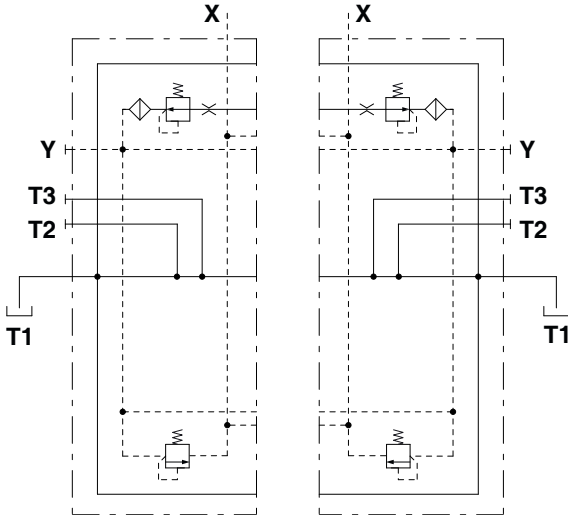

KZPH4 type circuit example

Right Inlet circuit

Left Inlet circuit

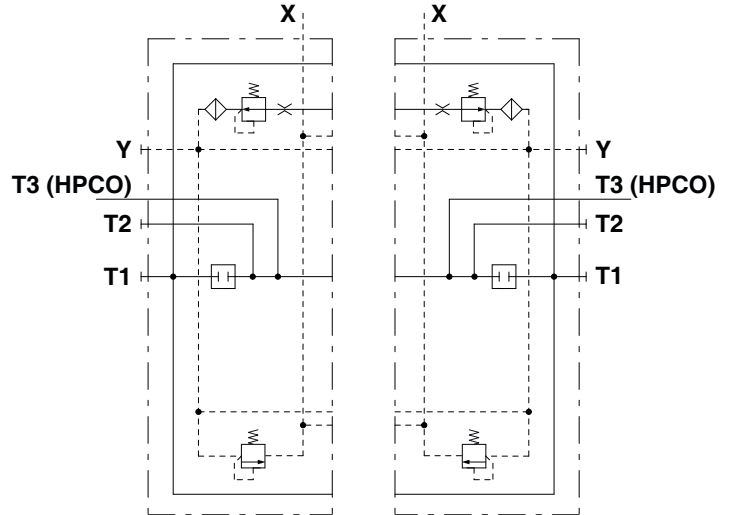

Port configuration

Type	T1 port	T2 port	T3 port	X drain	Y pilot	Backpressure valve	
KZP2	open	plugged	plugged	open	plugged	no	
KZP4	plugged	plugged	plugged	open	plugged	no	
KZP6	plugged	plugged	open	open	plugged	no	
KZPH3	plugged	HPCO open	plugged	open	plugged	no	
KZPH4	plugged	plugged	HPCO open	open	plugged	no	

Main rules

The DVS14 valve is assembled and tested as per the technical specifications of this catalogue.

Before the final installation on your equipment, please follow the below recommendations:

- the valve can be assembled in any position; in order to prevent body deformation and spool sticking, mount the product on a flat surface;
- In order to prevent the possibility of water entering the spool control kit, do not use high pressure washdown directly on the valve;
- prior to painting, ensure that plugs on normally open ports are tightly in place.

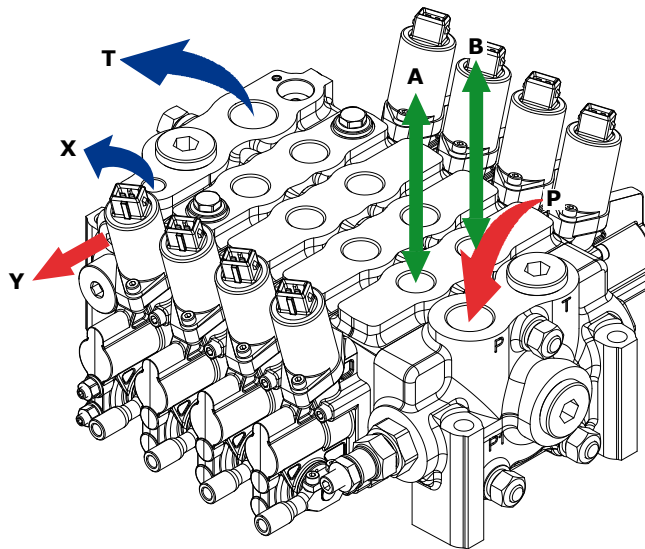

FITTING TIGHTENING TORQUE - Nm (lbft)

THREAD TYPE	P port	A and B ports	T and HPCO ports		Y pilot	X drain
BSP	G 3/4	G 1/2	G 3/4		G 1/4	G 1/4
With O-Ring seal	90 (66.4)	50 (36.9)	90 (66.4)		20 (14.8)	20 (14.8)
With copper washer	90 (66.4)	60 (44.3)	90 (66.4)		25 (18.4)	25 (18.4)
With steel and rubber washer	70 (51.6)	60 (44.3)	70 (51.6)		16 (11.8)	16 (11.8)
UN-UNF	1 1/6-12 (SAE 12)	7/8-14 (SAE 10)	1 1/6-12 (SAE 12)	7/8-14 (SAE 10)	9/16-18 (SAE 6)	9/16-18 (SAE 6)
With O-Ring seal	95 (70)	90 (66.4)	95 (70)	90 (66.4)	30 (22)	30 (22)

NOTE – These torques are recommended.

Assembly tightening torque depends on many factors, including lubrication, coating and surface finishing.

Carry-over transformation rules

KZM type outlet section

In order to transform the KZM outlet section in a HPCO carry-over configuration (picture 1), it is necessary to unscrew the **A** bottom plug, to insert the tapered **B** plug, **413010203** code, and to screw the **A** plug.

If the **C** plug is present, it is necessary to remove it from T1 port: this one will be used for HPCO.

If the HPCO port is no longer used, please remove the **B** tapered plug (picture 2) and, if necessary, close the T1 port with the **C** plug, **430000020** code.

Wrenches and tightening torques

- A = allen wrench 6 - 40 Nm (29.5 lbf^t)
- B = allen wrench 6 - 40 Nm (29.5 lbf^t)
- C = allen wrench 12 - 90 Nm (66.4 lbf^t)

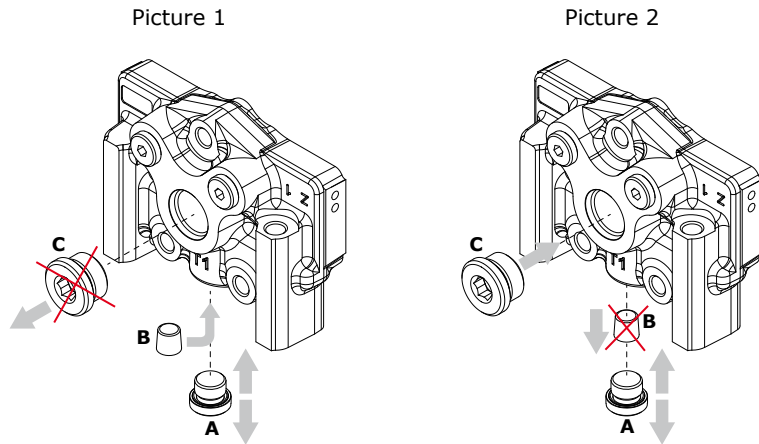

KZP type outlet section

If needed, a HPCO carry-over configuration is available on T2 or T3 ports.

It is necessary (picture 3) to remove the **A** backpressure valve and replaced it with the **B** plug, **4300C3004** code.

Select the port for HPCO configuration and remove one of the **C** plugs.

If the HPCO port is no longer used, please remove the **B** plug (picture 4), insert the **A** backpressure valve, **3202C3004** code, and close both the T2 and T3 ports with the **C** plug, **430000020** code.

Wrenches and tightening torques

- A = allen wrench 8 - 50 Nm (36.9 lbf^t)
- B = allen wrench 10 - 50 Nm (36.9 lbf^t)
- C = allen wrench 12 - 90 Nm (66.4 lbf^t)

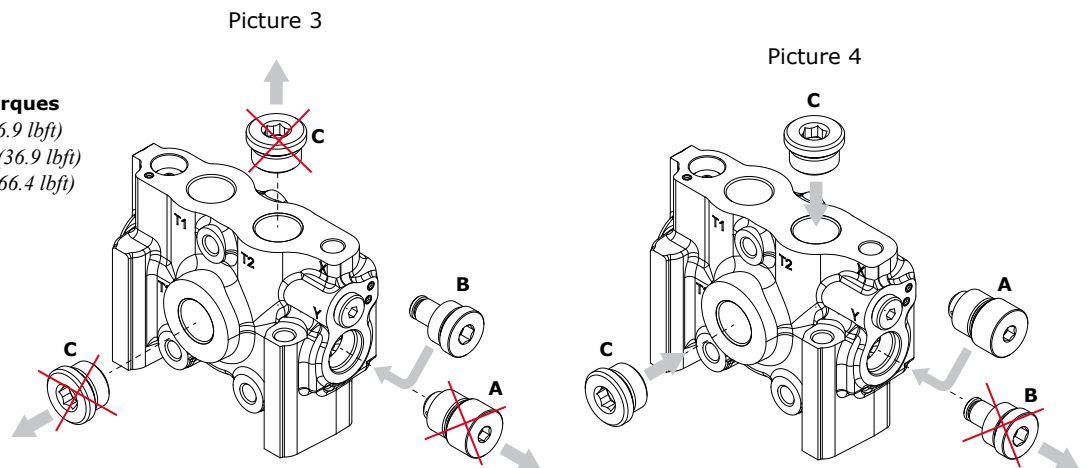

Two valves connection

This system, named IZ, allows the contemporary use of nr. 2 DVS14 valves when they are connected in parallel circuit and to the same pump.

The pump connected to the first DVS14 valve feeds also the pressure line of the second valve, while the "free flow line" from the HPCO of the first valve is connected to the "free flow line" of the following valve.

The pump can be connected indifferently to P or P1 ports of the first valve, while the HPCO must be connected to P1 port of the second DVS14 valve.

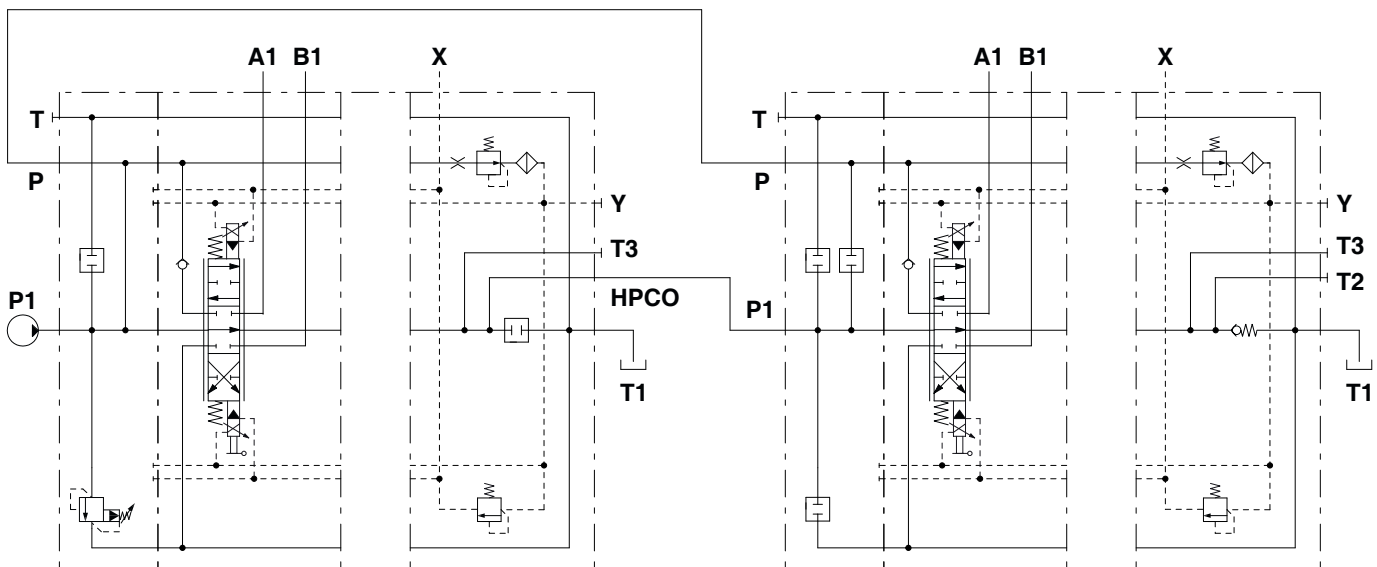
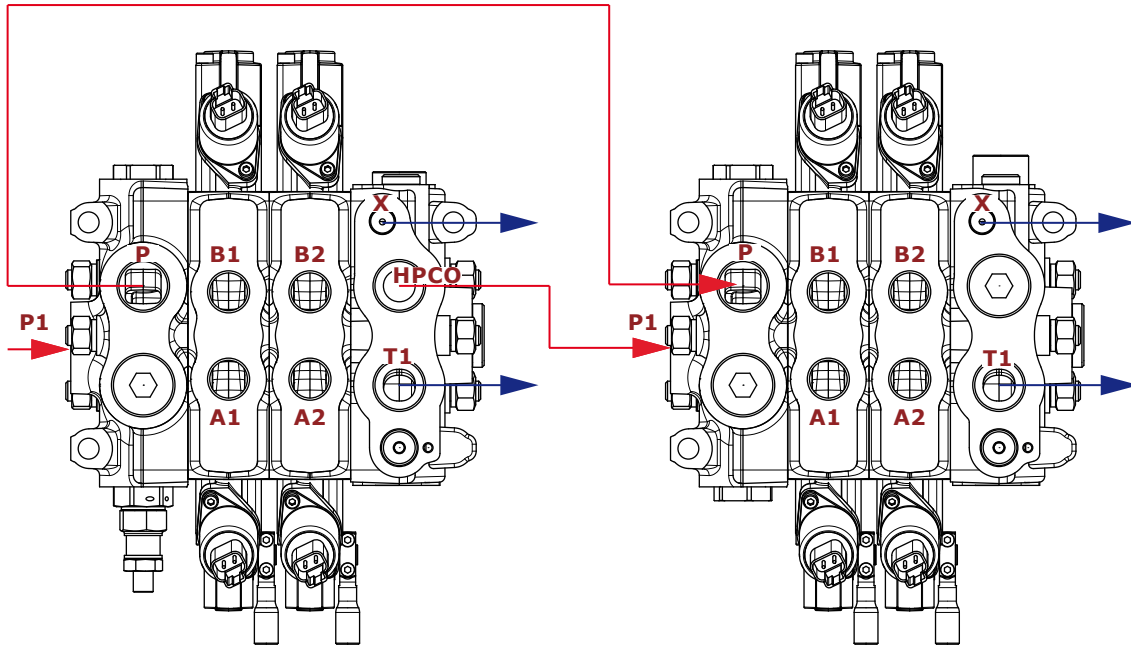

Coils and connectors

Dimensional data and features

Coil type	Voltage	Connectors					
		ISO4400	Deutsch DT	AMP JPT	Packard Weatherpack	Packard Metri-pack	Flying leads (without conn.)
BER	10 VDC	4SLE001000A	-	-	-	-	-
	12 VDC	4SLE001200A 4SLE001217A ⁽³⁾	4SLE001201A ⁽⁵⁾	-	-	-	-
			4SLE001209A ⁽³⁻⁵⁾	4SLE001203A ⁽⁵⁾	4SLE001210A ⁽²⁾	4SLE001214A ⁽²⁾	4SLE001207A
			4SLE001202A ⁽⁶⁾	4SLE001211A ⁽³⁻⁵⁾	-	-	-
			4SLE001216A ⁽³⁻⁶⁾	-	-	-	-
	14 VDC	-	4SLE001206A ⁽²⁾	4SLE001400A ⁽⁶⁾	4SLE001403A ⁽³⁻⁵⁾	-	-
			4SLE001401A ⁽³⁻⁶⁾	4SLE001402A ⁽³⁻⁵⁾	-	-	-
	24 VDC	4SLE002400A 4SLE002408A ⁽³⁾ 4SLE302400A ⁽¹⁾	4SLE002401A ⁽⁵⁾	4SLE002407A ⁽³⁻⁵⁾	4SLE002403A ⁽⁵⁾	-	4SLE002404A
			4SLE002402A ⁽⁶⁾	-	-	-	-
	28 VDC	-	4SLE002802A ⁽⁶⁾	4SLE002800A ⁽⁵⁾	-	-	-
48 VDC	4SLE004800A 4SLE304800A ⁽¹⁾	-	-	-	-	-	
110VDC	4SLE011000A 4SLE311000A ⁽¹⁾	-	-	-	-	-	
		-	-	-	-	-	
220 VDC	4SLE022000A 4SLE322000A ⁽¹⁾	-	-	-	-	-	
		-	-	-	-	-	
Mating connectors (For connector with rectifier see following table)		4CN1009995	5CON140031	5CON003	5CON001	5CON017	-

Note: ⁽¹⁾ supply with AC and use only with rectifier connector - ⁽²⁾ with flying leads - ⁽³⁾ with bidirectional diode - ⁽⁴⁾ with unidirectional diode - ⁽⁵⁾ integrated perpendicular type - ⁽⁶⁾ integrated parallel type

Voltage	ISO 4400 mating connector with rectifier	
	BER type coil	
24 VDC	4CN1010240	
48 VDC	4CN1010480	
110 VDC	4CN1011100	
220 VDC	4CN1012200	

Coils and connectors

Dimensional data and features

BER type

ISO4400 connector

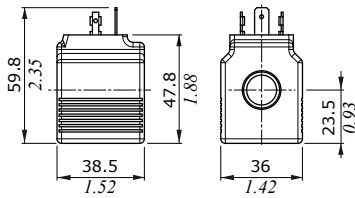

AMP JPT connector

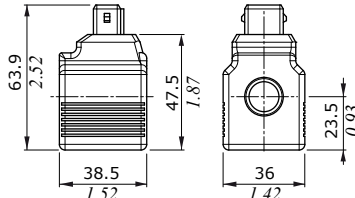

DEUTSCH DT04 connector
(parallel type)

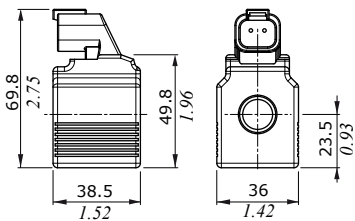

DEUTSCH DT04 connector
(perpendicular type)

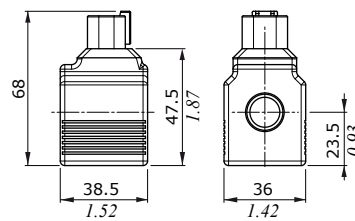

Features

- Nominal voltage tolerance : ±10%
- Power rating : 19.2 W - 12/24 VDC - 48 RAC
: 19.1 W - 28 VDC
: 19 W - 10/14/48/110/220 VDC
: 24/110/220 RAC
- Max. operating current . . . : 1.90 A - 10 VDC
: 1.60 A - 12 VDC
: 1.36 A - 14 VDC
: 0.80 A - 24 VDC
: 0.68 A - 28 VDC
: 0.40 A - 48 VDC
: 0.17 A - 110 VDC
: 0.09 A - 220 VDC
: 0.89 A - 24 RAC
: 0.45 A - 48 RAC
: 0.19 A - 110 RAC
: 0.09 A - 220 RAC
- Coil insulation : Class H (180°C - 356°F)
- Weather protection : IP65 - ISO4400
: IP69K - Deutsch DT
: IP65 - AMP JPT
: IP67 - Weatherpack
: IP67 - Metri-pack
- Insertion : 100%

Flying leads

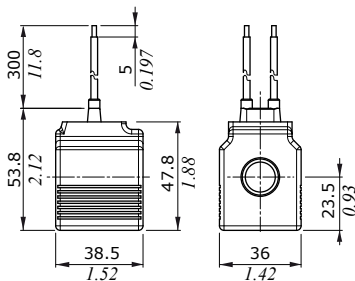

Flying leads with
DEUTSCH DT04 connector

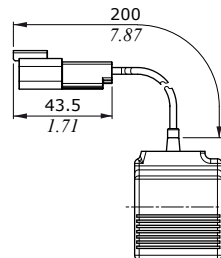

Flying leads with PACKARD
WEATHER-PACK connector

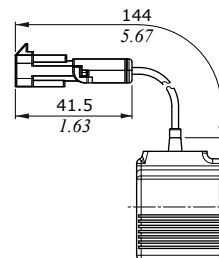

Flying leads with PACKARD
METRI-PACK connector

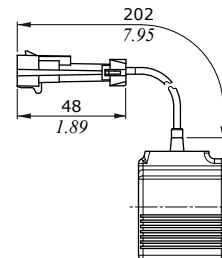



Innovation · Continuity · Integration
————— It is Power —————

 **walvoil**
FLUID POWER E|MOTION

 **walvoil**

 **hydro control**

 **Caltex**

D1WHEB12E
5th edition November 2021

Walvoil S.P.A. • 42124 Reggio Emilia • Italy • Via Adige, 13/D • Tel. +39.0522.932411 • Fax +39.0522.300984
www.walvoil.com

