



BREVINI[®]

Motion Systems



1800-OILSOL
1800-645765

<https://oilsolutions.com.au/>

sales@oilsolutions.com.au

HAND PUMPS

Technical Catalogue

January
2018

web edition

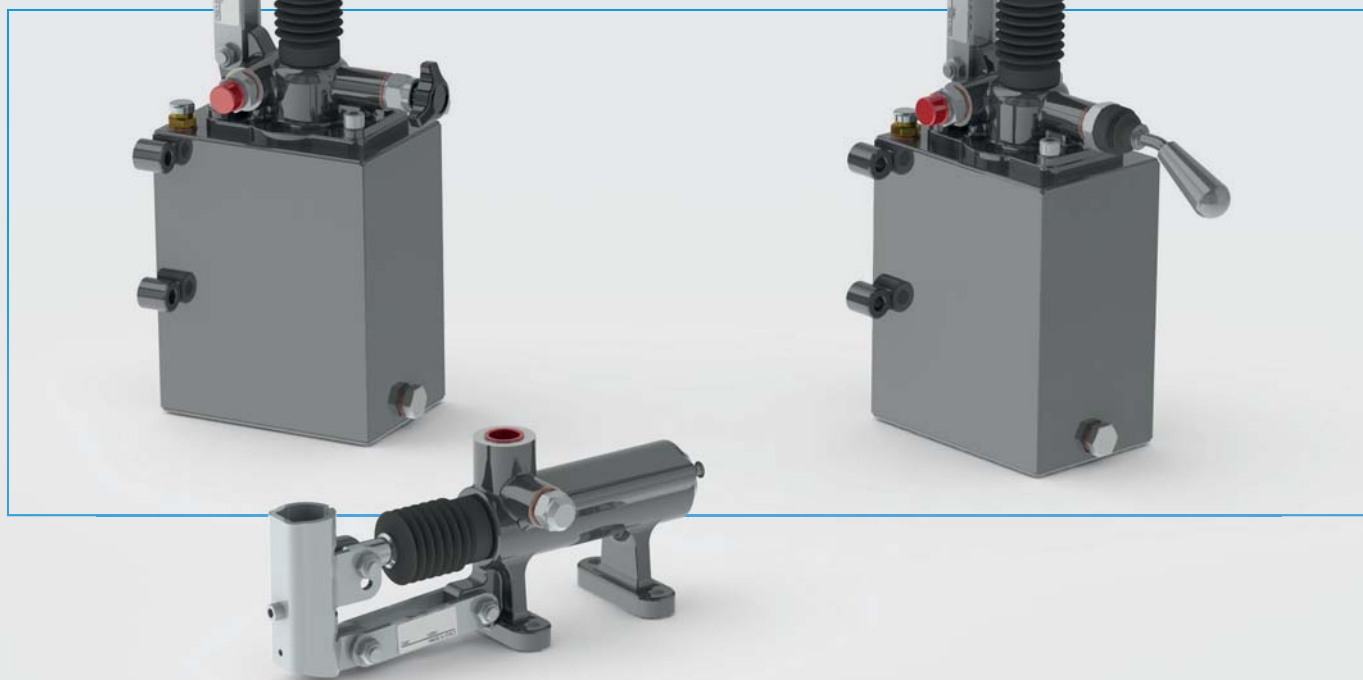

Table of contents

How to order	2
Technical information	3

HAND PUMPS FOR FIXING TO TANK

Double acting

PM 06/12/25/45 S** 00 2	5
PM 06/12/25/45 S** 02 2	6
PM 06/12/25/45 S** 03 2	7
PM 06/12/25/45 S** 14 2	8
PM 06/12/25/45 S** 11 2	9
PM 06/12/25/45 S** 12 2	10

Double acting and flow divider

PMI 06/12/25/45 S** 04 2	11
PMI 06/12/25/45 S** 05 2	12
PMI 06/12/25/45 S** 00 2	13
PMI 06/12/25/45 S** 06 2	14

Double acting, flow divider and dual pilot check valve

PMB 06/12/25/45 S** 00 2	15
PMB 06/12/25/45 S** 07 2	16
PMB 06/12/25/45 S** 08 2	17
PMB 06/12/25/45 S** 09 2	18

Single acting

1PMS 20/30/40 S** 00 2	19
1PMS 20/30/40 S** 02 2	20
1PMS 20/30/40 S** 03 2	21

Horizontal

2PMS 08/15 S** 00 2	22
2PMS 08/15 S** 02 2	23
2PMS 08/15 S** 03 2	24

Steel oil tanks	25
------------------------------	-----------

HAND PUMPS FOR FIXING TO WALL

PM 020 00 2	26
PM 020 03 2	27
PM 020 10 2	28
PM 050 00 2	29
PM 050 03 2	30
PM 050 10 2	31

Lever for hand pumps	32
-----------------------------------	-----------

SPECIAL PUMPS

PMP 12 003	33
------------------	----

© 2018 Dana Brevini S.p.A. all rights reserved. Hydr-App, SAM Hydraulik, Aron, Brevini Hydraulics, BPE Electronics, VPS Brevini, OT Oiltechnology, logos are trademarks or are registered trademarks of Dana Brevini S.p.A. or other companies Dana in Italy and other countries.

The technical features supplied in this catalogue are non binding and no legal action can be taken against such material. Dana Brevini will not be held responsible for information and specifications which may lead to error or incorrect interpretations. Given the continuous technical research aimed at improved technical features of our products, Dana Brevini reserves the right to make change that are considered appropriate without any prior notice. This catalogue cannot be reproduced (in whole or in part) without the prior written consent of Dana Brevini. This catalogue supersedes all previous ones.

Use of the products in this catalogue must comply with the operating limits given in the technical specifications. The type of application and operating conditions must be assessed as normal or in malfunction in order to avoid endangering the safety of people and/or items.

Hand pump for fixing to tank (without lever*)

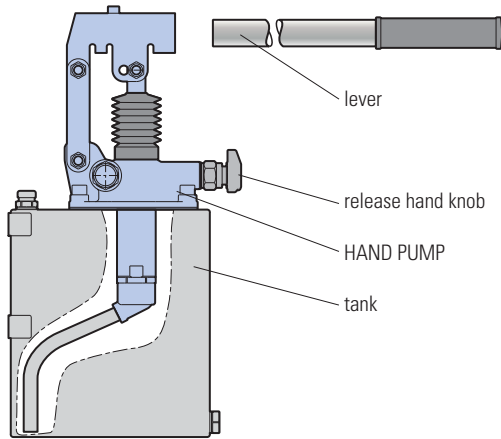

Hand pump for fixing to wall (without lever*)

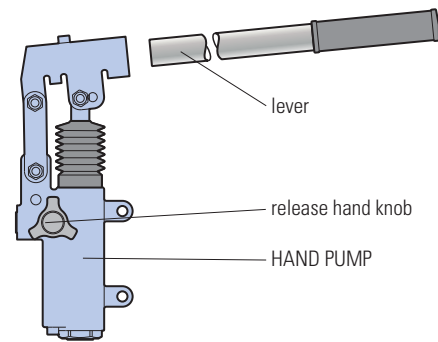

* The lever has to be ordered separately, see page 32

Type	Displacement cm ³	Tank Liter	Variants	Serie	
Fixing to tank	PM	06	S00 no S01 1 lt. S02 2 lt. S03 3 lt. S05 5 lt. S07 7 lt. S10 10 lt.	00 01 02 03 ..	2
	PMI	12			
	PMB	25			
		45			
	1PMS	20			
		30			
		40			
	2PMS	08			
		15			
	Fixing to wall	PM			
		050			

INTRODUCTION

Hand pumps are generally employed for intermittent or emergency applications. The wide range for integrated applications with auxiliary valves allow the solution of any requirement. UNI/ISO 185 cast-iron body, high resistance lapped and nicked steel rod.

They are available in wall bracket and flangeable on tank versions with various types of pumping (in both senses or oneway). They can be supplied with steel tanks with antioil paint and capacities from 1 lt. up to 10 lt.

Read this instructions carefully before installation. All operations must be carried out by qualified personnel following the instructions.

The user must periodically inspect, based on the conditions of use and the substances used, the presence of corrosion, dirt, the state of wear and correct function of the valves.

Always observe first the operating conditions given in datasheet of the valve.

CONVERSION TABLE SSU / °E / mm²/s

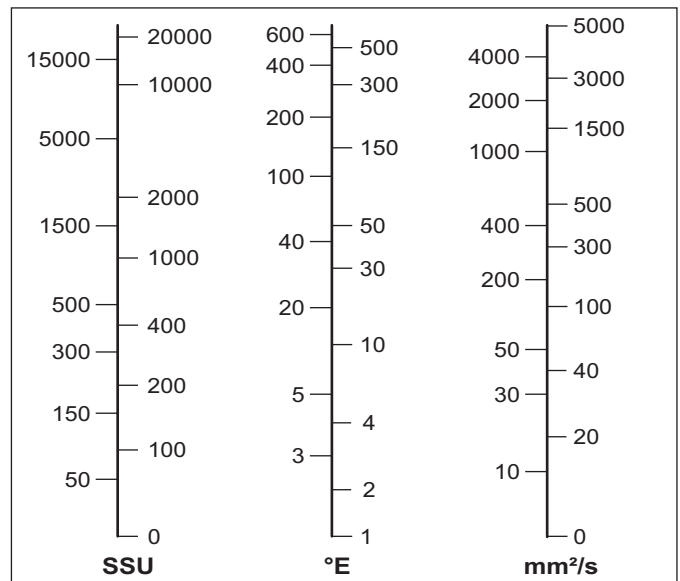

HYDRAULIC FLUID

Use only mineral oil (HL, HLP) according to DIN 51524. Use of other different fluids may damage the good operation of the valve.

VISCOSITY

The oil viscosity must be in the range of 10 mm²/s to 500 mm²/s.

Table 1: ISO viscosity grades

Viscosity grade	Average kinematic viscosity mm ² /s @ 40°C	Kinematic-viscosity limits mm ² /s @ 40°C	
		min.	max.
ISO VG 10	10	9.00	11.0
ISO VG 15	15	13.5	16.5
ISO VG 22	22	19.8	24.2
ISO VG 32	32	28.8	35.2
ISO VG 46	46	41.4	50.6
ISO VG 68	68	61.2	74.8
ISO VG 100	100	90.0	110

 = Values used in the chart "Oil viscosity according to temperature"

OIL VISCOSITY ACCORDING TO TEMPERATURE

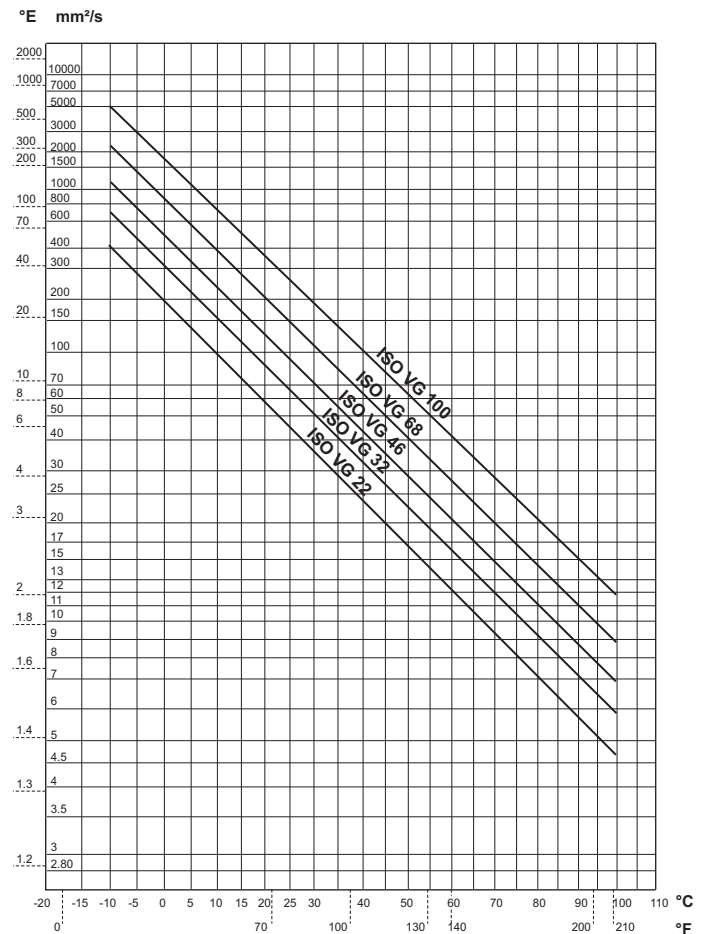

CONTAMINATION

Oil contamination is the main cause of faults and malfunction in hydraulic systems. Abrasive particles in the fluid erode or block moving parts, leading to system malfunction.

However, accurate filtering does guarantee reliability and a long life to all the system's hydraulic parts. Reliable performance and long working life for all oil-pressure parts is assured by maintaining the level of fluid contamination within the limits specified in the data sheet of the pump.

Hydraulic fluid must also be cleaned properly before filling the hydraulic circuit, especially when commissioning a new system, as this is when the oil contamination generally peaks due to its flushing effect on the components, and the running-in of the pump.

The standard ISO 4406:1999 defines the contamination level with three numbers that relate with the number of particles of average dimension equal or greater than 4 µm, 6 µm e 14 µm, in 1 ml of fluid.

In following table there is a reference to recommended contamination level and correspondence with old NAS 1638 standard.

Table 2: Recommended contamination level.

Type of system Type of valve	Oil filtration recommendations		
	Cleanliness class recommended		Absolute filtration micron rating (**)
	ISO 4406 : 1999	NAS 1638 (*)	
Systems or components operating at HIGH PRESSURE > 250 bar (3600 psi) HIGH DUTY CYCLE APPLICATIONS Systems or components with LOW dirt tolerance	18 / 16 / 13	7 - 8	5
Systems or components operating at MEDIUM / HIGH PRESSURE Systems and components with moderate dirt tolerance	19 / 17 / 14	9	10
Systems or components operating at LOW PRESSURE < 100 bar (1500 psi) LOW DUTY CYCLE APPLICATIONS Systems and components with GOOD dirt tolerance	20 / 18 / 15	10 - 11	20

* Contamination class NAS 1638: it is determined by counting the total particles of different size ranges contained in 100 ml of fluid.

** Absolute filtration: it is a characteristic of each filter, it refers the size (in micron) of the largest spherical particle which may pass through the filter.

WORKING TEMPERATURES

Ambient temperature range: -25°C to +60°C
Fluid temperature range (NBR seals): -25°C to +75°C

USE AND MAINTENANCE

Observe the functional limits indicated in the technical catalogue
On a periodic basis and based on the conditions of use, check for cleanliness, state of wear or fractures and correct performance of the pump.

If the O-rings are damaged, replace them with those supplied by the manufacturer.

To assure the best working conditions at all time, check the oil and replace it periodically (after the first 100 working hours and then after every 2000 working hours or at least once every year).

Attention: all installation and maintenance intervention must be performed by qualified staff.

TRANSPORT AND STORAGE

The pump must be handled with care to avoid damage caused by impact, which could compromise its efficiency.

In the case of storage, keep the pump in a dry place and protect against dust and corrosive substances.

When storing for periods of more than 6 months, fill the pump with preserving oils and seal it.

CONVERSION CHART

Type	SI units		Alternative units		Conversion factor
Force	Newton	(N) [kgm/s ²]	Kilogram force	(kgf)	1 kgf = 9.807 N
			pound force	(lbf) [lbf/s ²]	1 lbf = 4.448 N
Length	millimeter	(mm) [10 m]	inch	(in)	1 in = 25.4 mm
	meter	(km) [1000 m]	yard	(yd) [3ft]	1 m = 1.0936 yd
	kilometer	(km) [1000 m]	mile	(mile) [1760 yd]	1 mile = 1.609 km
Torque	Newton meter	(Nm)	pound force.feet	(lbf.ft)	1 lbf.ft = 1.356 Nm
Power	kiloWatt (kW)	[1000 Nm/s]	horsepower	(hp)	1 kW = 1.341 hp
			metric horsepower	(CV)	1 kW = 1.36 CV
Pressure	MegaPascal	(MPa) [N/mm ²]	bar		1 MPa = 10 bar
			psi (lbf/in ²)		1 MPa = 145 psi
			ton/f/in ²		1 ton/f/in ² = 15.45 MPa
Flow rate	liter/min	(l/min)	UK gal/min		1 UK gal/min = 4.546 l/min
			US gal/min		1 US gal/min = 3.785 l/min
Temperature	Degrees Celsius	(°C)	Fahrenheit	(°F)	1°F = 1.8 °C+32

HAND PUMP WITH RELEASE HAND KNOB

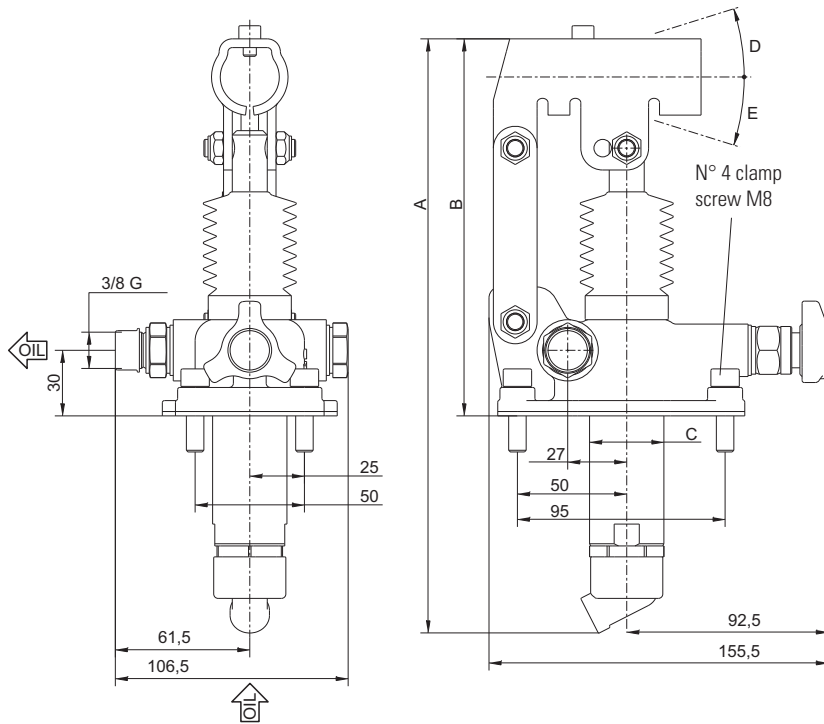

With release hand knob
Double acting hand pump for single acting cylinder
For fixing to tank

Specifications:

- Cast iron body
- Piston treated with Niploy
- White zinc plated support lever
- Lever connection Ø 27
- White zinc plated external parts
- Standard colour black
- Oil tank mounting kit included

Ordering code				A mm	B mm	C mm	D °	E °	Nominal displac. cm ³	Actual displac. cm ³	Pressure BAR		Mass kg	Lever
Type	Tank	Variant	No. serie								Optimal	Max		
PM06	S** (pag. 25)	00	2	253	166	34	26	31	6	6,970	420	500	2,90	pag. 32
PM12				253	166	34	26	31	12	12,095	220	380	2,90	
PM25				273	172	34	30	30	25	25,280	120	350	2,95	
PM45				283	172	40	45	33	45	44,532	80	280	3,00	

EFFORT DIAGRAM

HYDRAULIC DIAGRAM

pin in D (distance between centers 40 mm) PM 06 - PM 12
 pin in E (distance between centers 51 mm) PM 25 - PM 45

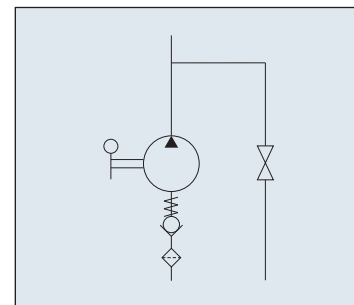
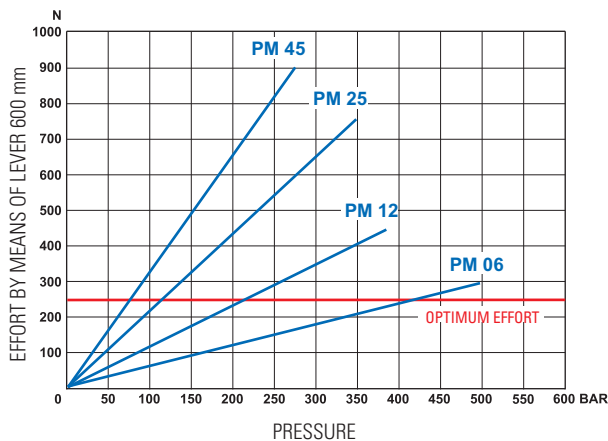

HAND PUMP WITH RELIEF VALVE AND RELEASE HAND KNOB

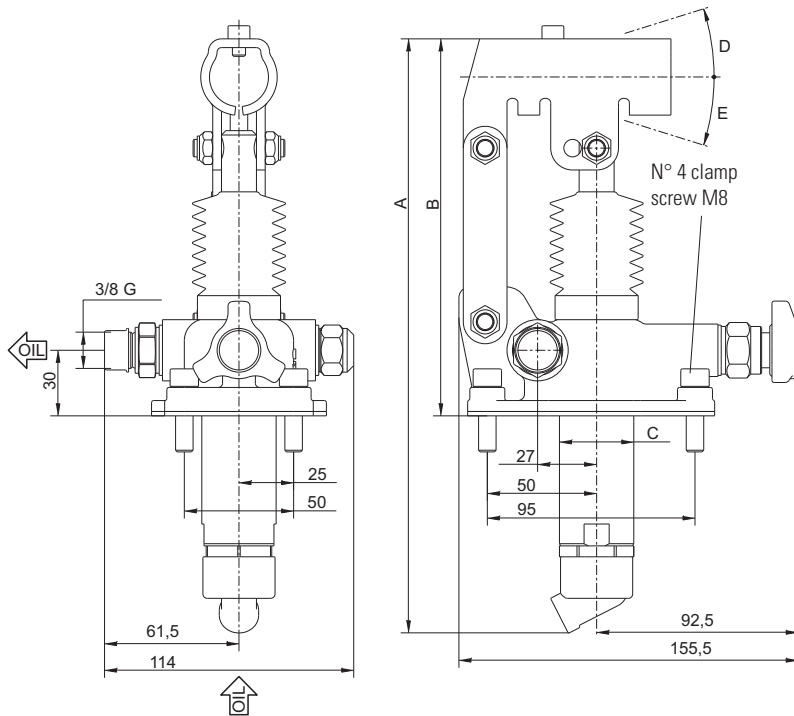

With pressure relief valve
With release hand knob
Double acting hand pump for single cylinder
For fixing to tank

Specifications:

- Cast iron body
- Piston treated with Niploy
- White zinc plated support lever
- Lever connection Ø 27
- White zinc plated external parts
- Standard colour black
- Oil tank mounting kit included
- Pressure relief valve standard setting: 100 bar (others settings upon request).

Ordering code				A mm	B mm	C mm	D °	E °	Nominal displac. cm ³	Actual displac. cm ³	Pressure BAR		Mass kg	Lever
Type	Tank	Variat	No. serie								Optimal	Max		
PM06	S** (pag. 25)	02	2	253	166	34	26	31	6	6,970	420	500	2,90	pag. 32
PM12				253	166	34	26	31	12	12,095	220	380	2,90	
PM25				273	172	34	30	30	25	25,280	120	350	2,95	
PM45				283	172	40	45	33	45	44,532	80	280	3,00	

EFFORT DIAGRAM

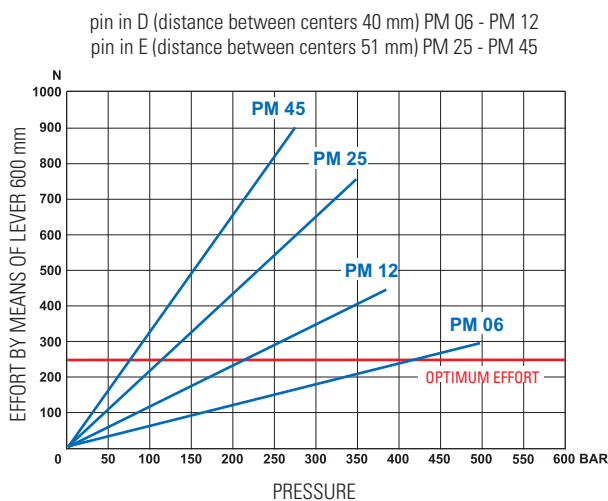

HYDRAULIC DIAGRAM

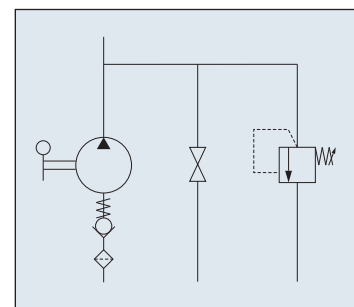

HAND PUMP WITHOUT RELEASE HAND KNOB

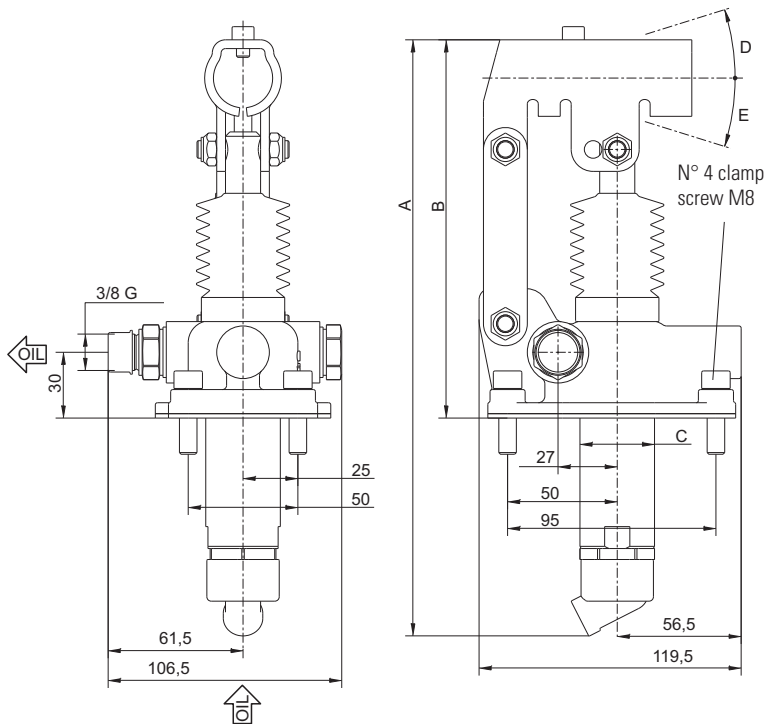

Without release hand knob
Double acting hand pump for single
For fixing to tank

Specifications:

- Cast iron body
- Piston treated with Niploy
- White zinc plated support lever
- Lever connection Ø 27
- White zinc plated external parts
- Standard colour black
- Oil tank mounting kit included

Ordering code				A mm	B mm	C mm	D °	E °	Nominal displac. cm ³	Actual displac. cm ³	Pressure BAR		Mass kg	Lever
Type	Tank	Variant	No. serie								Optimal	Max		
PM06	S** (pag. 25)	03	2	253	166	34	26	31	6	6,970	420	500	2,90	pag. 32
PM12				253	166	34	26	31	12	12,095	220	380	2,90	
PM25				273	172	34	30	30	25	25,280	120	350	2,95	
PM45				283	172	40	45	33	45	44,532	80	280	3,00	

EFFORT DIAGRAM

HYDRAULIC DIAGRAM

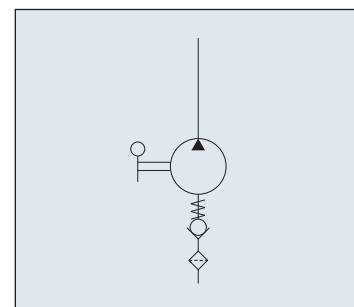
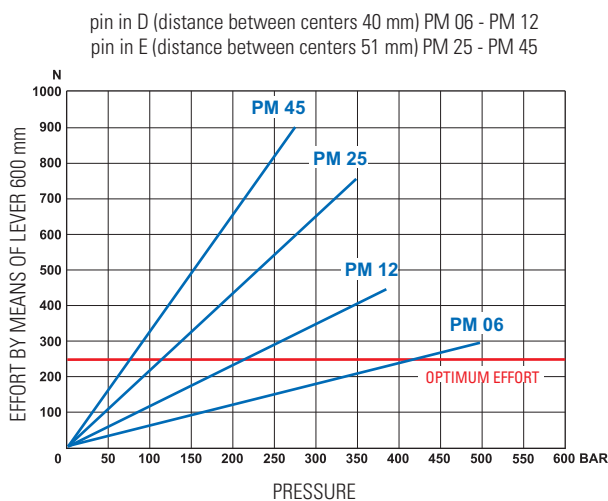

HAND PUMP WITH RELIEF VALVE WITHOUT RELEASE HAND KNOB

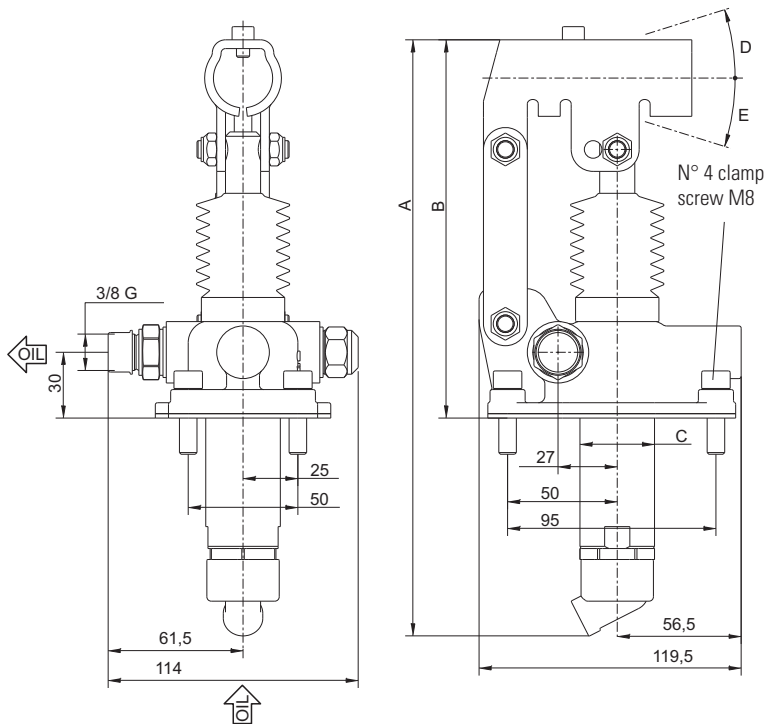

Without release hand knob
With pressure relief valve
Double acting hand pump for single
For fixing to tank

Specifications:

- Cast iron body
- Piston treated with Niploy
- White zinc plated support lever
- Lever connection Ø 27
- White zinc plated external parts
- Standard colour black
- Oil tank mounting kit included
- Pressure relief valve standard setting: 100 bar (others settings upon request).

Ordering code				A mm	B mm	C mm	D °	E °	Nominal displac. cm ³	Actual displac. cm ³	Pressure BAR		Mass kg	Lever
Type	Tank	Variat	No. serie								Optimal	Max		
PM06	S** (pag. 25)	14	2	253	166	34	26	31	6	6,970	420	500	2,90	pag. 32
PM12				253	166	34	26	31	12	12,095	220	380	2,90	
PM25				273	172	34	30	30	25	25,280	120	350	2,95	
PM45				283	172	40	45	33	45	44,532	80	280	3,00	

EFFORT DIAGRAM

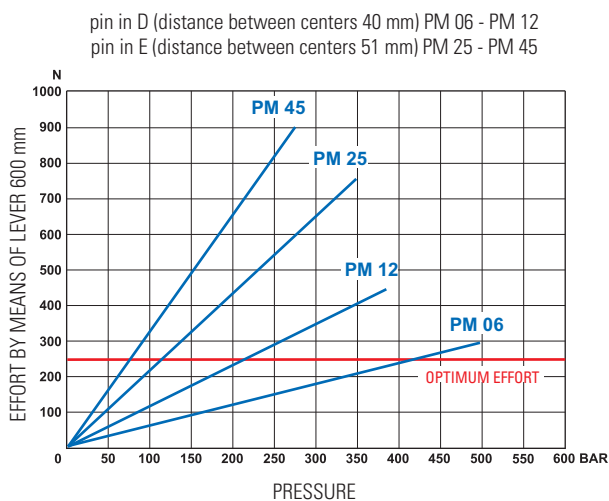

HYDRAULIC DIAGRAM

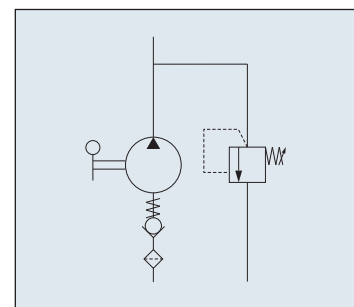

HAND PUMP WITH NORMALLY CLOSED MANIPULATOR

With normally closed manipulator
Double acting hand pump for single acting cylinder
For fixing to tank

Specifications:

- Cast iron body
- Piston treated with Niploy
- White zinc plated support lever
- Lever connection Ø 27
- White zinc plated external parts
- Standard colour black
- Oil tank mounting kit included

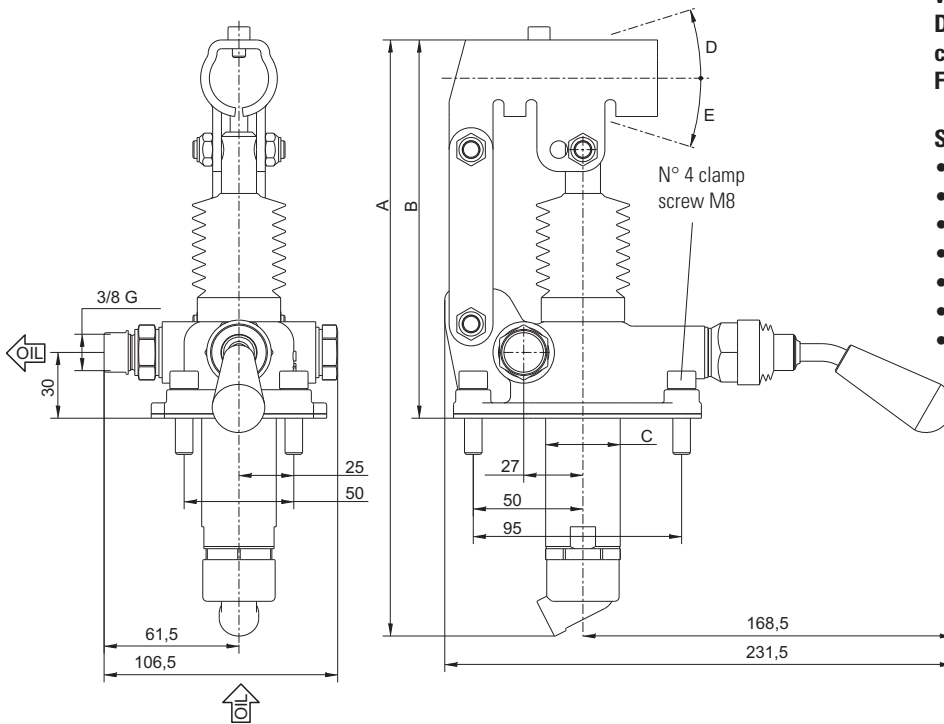

Ordering code				A mm	B mm	C mm	D °	E °	Nominal displac. cm ³	Actual displac. cm ³	Pressure BAR		Mass kg	Lever
Type	Tank	Variant	No. serie								Optimal	Max		
PM06	S** (pag. 25)	11	2	253	166	34	26	31	6	6,970	420	500	2,90	pag. 32
PM12				253	166	34	26	31	12	12,095	220	380	2,90	
PM25				273	172	34	30	30	25	25,280	120	350	2,95	
PM45				283	172	40	45	33	45	44,532	80	280	3,00	

EFFORT DIAGRAM

HYDRAULIC DIAGRAM

pin in D (distance between centers 40 mm) PM 06 - PM 12
 pin in E (distance between centers 51 mm) PM 25 - PM 45

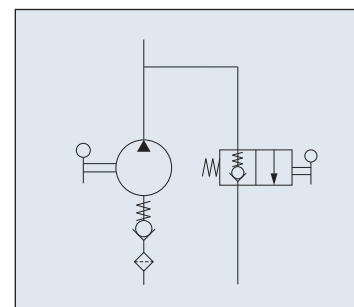
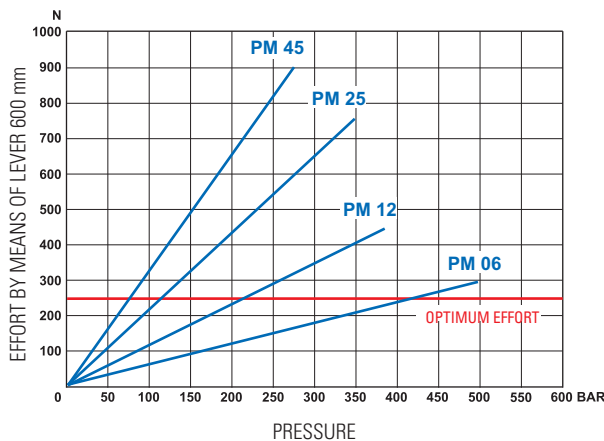

HAND PUMP WITH RELIEF VALVE AND NORMALLY CLOSED MANIPULATOR

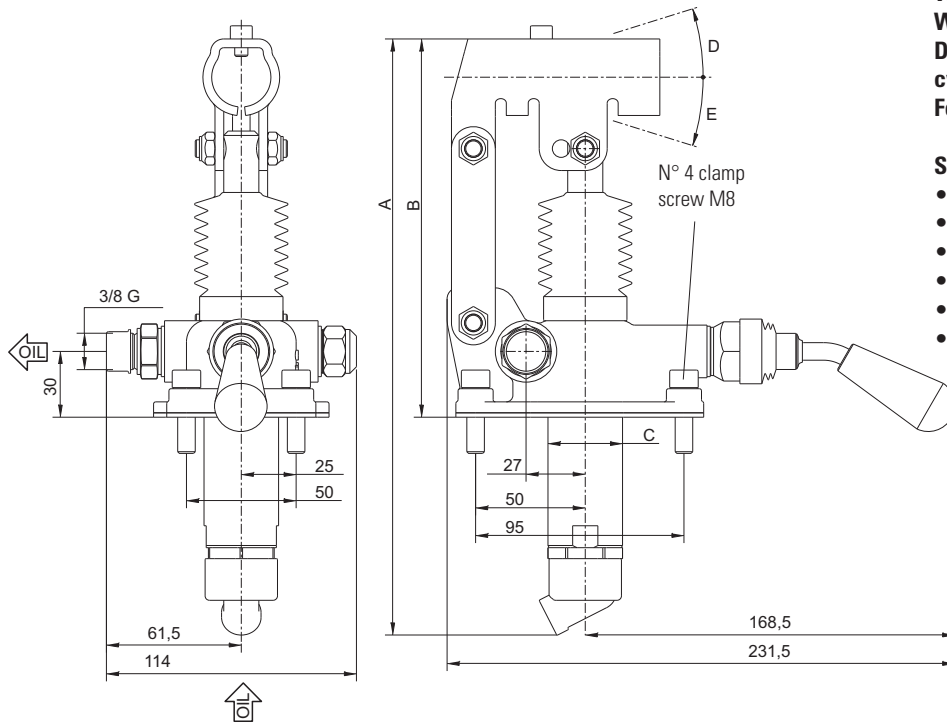

With normally closed manipulator
 With pressure relief valve
 Double acting hand pump for single acting cylinder
 For fixing to tank

Specifications:

- Cast iron body
- Piston treated with Niploy
- White zinc plated support lever
- Lever connection Ø 27
- White zinc plated external parts
- Standard colour black
- Oil tank mounting kit included
- Pressure relief valve standard setting: 100 bar (others settings upon request).

Ordering code				A mm	B mm	C mm	D °	E °	Nominal displac. cm ³	Actual displac. cm ³	Pressure BAR		Mass kg	Lever
Type	Tank	Variat	No. serie								Optimal	Max		
PM06	S** (pag. 25)	12	2	253	166	34	26	31	6	6,970	420	500	2,90	pag. 32
PM12				253	166	34	26	31	12	12,095	220	380	2,90	
PM25				273	172	34	30	30	25	25,280	120	350	2,95	
PM45				283	172	40	45	33	45	44,532	80	280	3,00	

EFFORT DIAGRAM

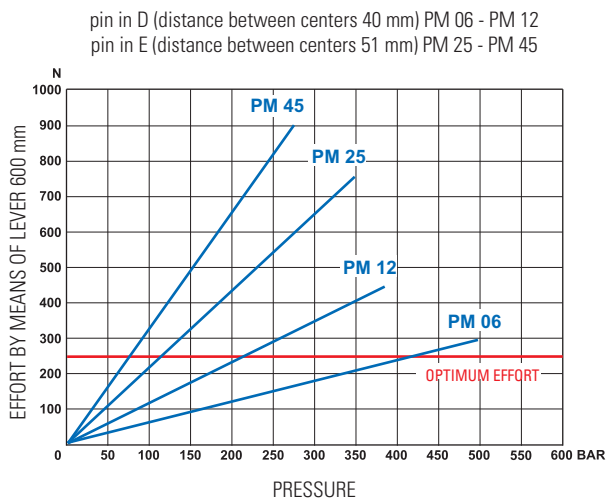

HYDRAULIC DIAGRAM

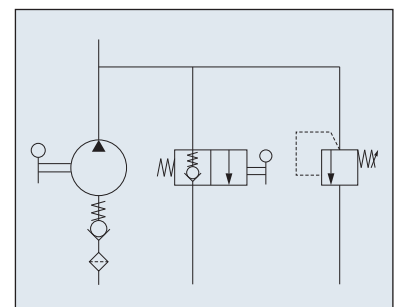

HAND PUMP WITH 4/3 FLOW DIVIDER CLOSED CENTRE AND PRESSURE RELIEF VALVE

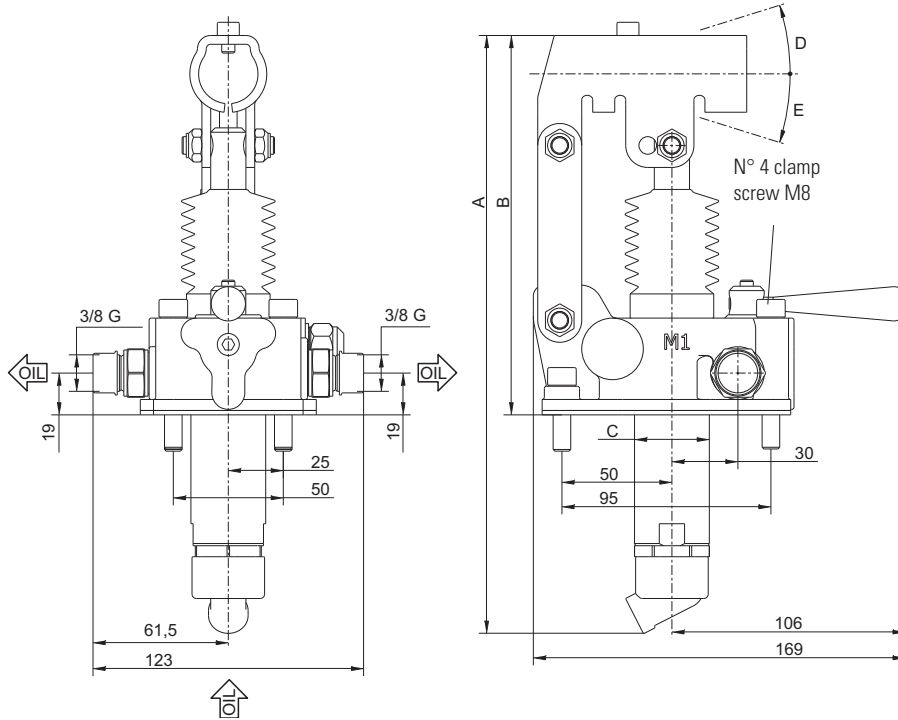

With 4/3 flow divider closed centre
 With pressure relief valve
 Double acting hand pump for a double acting cylinder
 For fixing to tank

Specifications:

- Cast iron body
- Piston treated with Niploy
- White zinc plated support lever
- Lever connection Ø 27
- White zinc plated external parts
- Standard colour black
- Oil tank mounting kit included
- Pressure relief valve standard setting: 100 bar (others settings upon request).

Ordering code				A mm	B mm	C mm	D °	E °	Nominal displac. cm ³	Actual displac. cm ³	Pressure BAR		Mass kg	Lever
Type	Tank	Variant	No. serie								Optimal	Max		
PMI06	S** (pag. 25)	04	2	253	166	34	26	31	6	6,970	420	500	3,40	pag. 32
PMI12				253	166	34	26	31	12	12,095	220	380	3,40	
PMI25				273	172	34	30	30	25	25,280	120	350	3,45	
PMI45				283	172	40	45	33	45	44,532	80	280	3,50	

EFFORT DIAGRAM

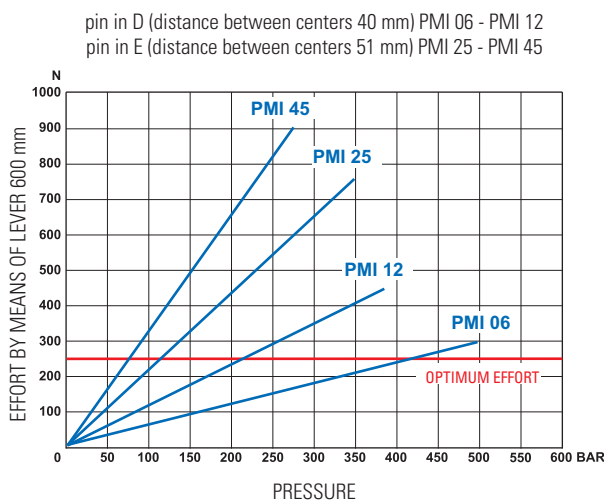

HYDRAULIC DIAGRAM

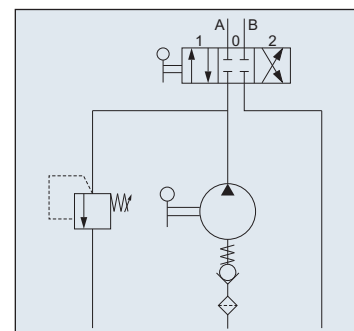

HAND PUMP WITH 4/3 FLOW DIVIDER CLOSED CENTRE AND RELEASE LEVER

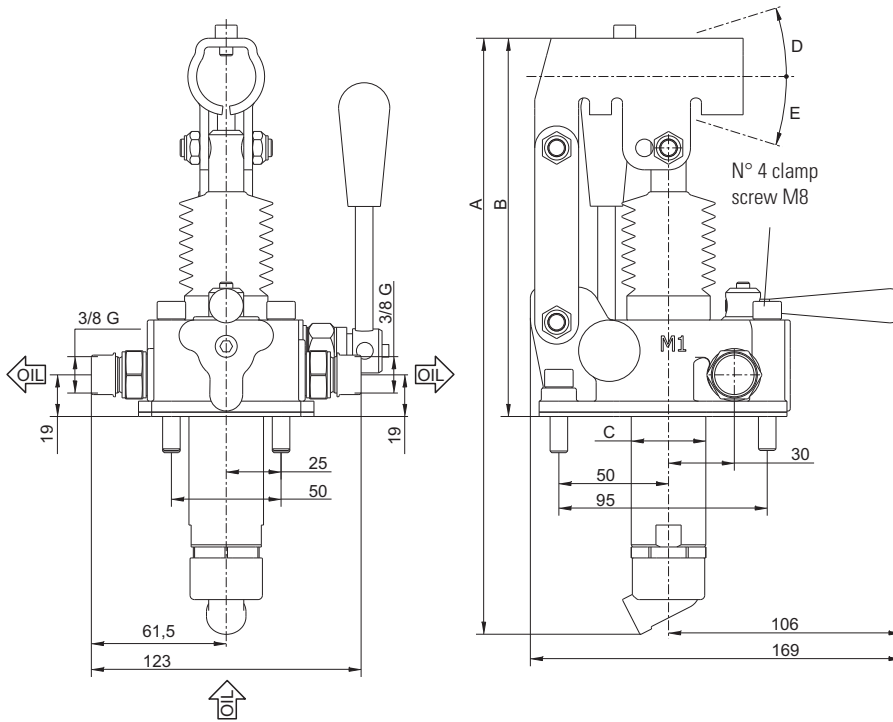

With 4/3 flow divider closed centre
 With release lever
 Double acting hand pump for a double acting cylinder
 For fixing to tank

Specifications:

- Cast iron body
- Piston treated with Niploy
- White zinc plated support lever
- Lever connection Ø 27
- White zinc plated external parts
- Standard colour black
- Oil tank mounting kit included

Ordering code				A mm	B mm	C mm	D °	E °	Nominal displac. cm ³	Actual displac. cm ³	Pressure BAR		Mass kg	Lever
Type	Tank	Variant	No. serie								Optimal	Max		
PMI06	S** (pag. 25)	05	2	253	166	34	26	31	6	6,970	420	500	3,40	pag. 32
PMI12				253	166	34	26	31	12	12,095	220	380	3,40	
PMI25				273	172	34	30	30	25	25,280	120	350	3,45	
PMI45				283	172	40	45	33	45	44,532	80	280	3,50	

EFFORT DIAGRAM

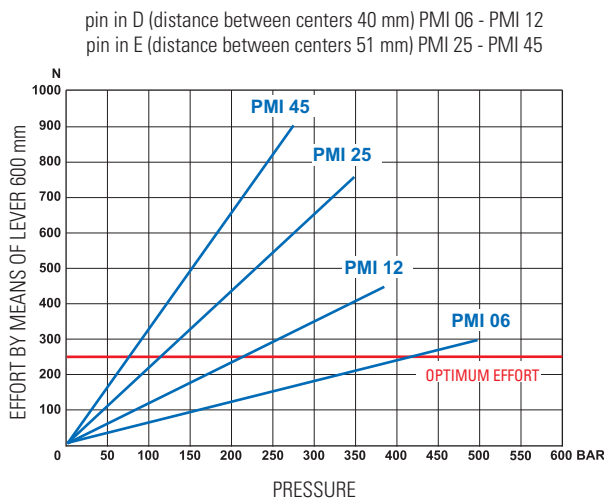

HYDRAULIC DIAGRAM

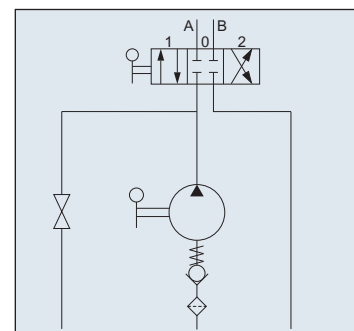

HAND PUMP WITH 4/3 FLOW DIVIDER CLOSED CENTRE

With 4/3 flow divider closed centre
Double acting hand pump for a double acting cylinder
For fixing to tank

Specifications:

- Cast iron body
- Piston treated with Niploy
- White zinc plated support lever
- Lever connection Ø 27
- White zinc plated external parts
- Standard colour black
- Oil tank mounting kit included

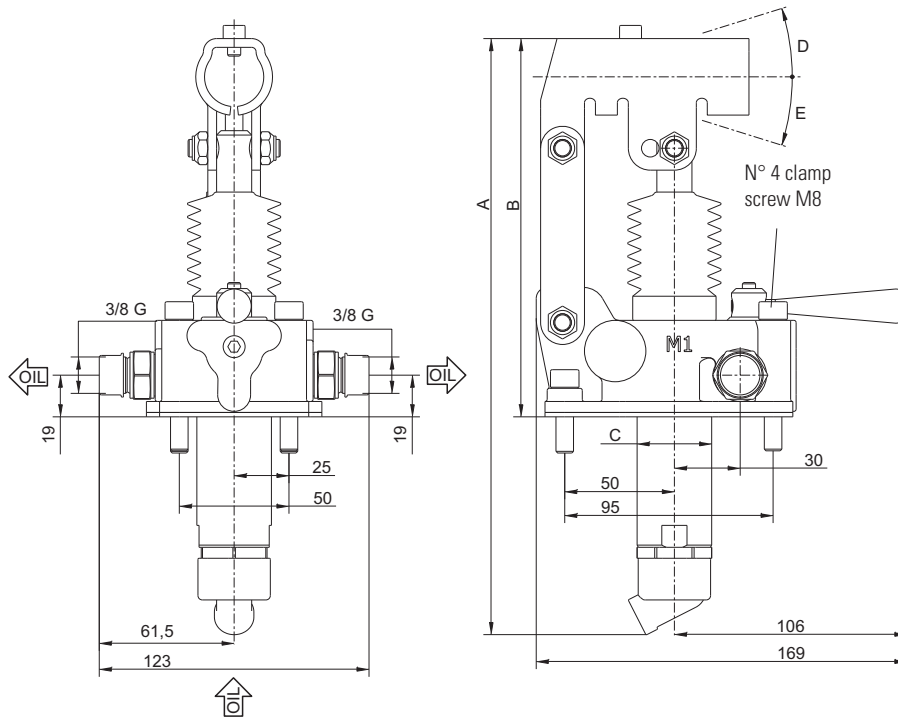

Ordering code				A mm	B mm	C mm	D °	E °	Nominal displac. cm ³	Actual displac. cm ³	Pressure BAR		Mass kg	Lever
Type	Tank	Variant	No. serie								Optimal	Max		
PMI06	S** (pag. 25)	00	2	253	166	34	26	31	6	6,970	420	500	3,40	pag. 32
PMI12				253	166	34	26	31	12	12,095	220	380	3,40	
PMI25				273	172	34	30	30	25	25,280	120	350	3,45	
PMI45				283	172	40	45	33	45	44,532	80	280	3,50	

EFFORT DIAGRAM

HYDRAULIC DIAGRAM

pin in D (distance between centers 40 mm) PMI 06 - PMI 12
 pin in E (distance between centers 51 mm) PMI 25 - PMI 45

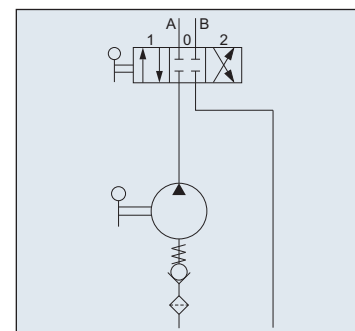
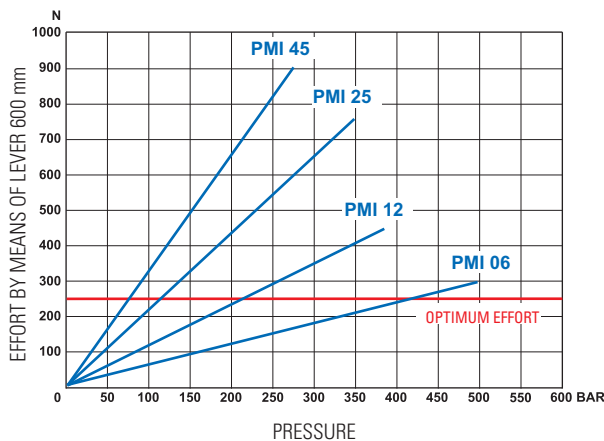

HAND PUMP WITH 4/3 FLOW DIVIDER CLOSED CENTRE RELEASE LEVER AND PRESSURE RELIEF VALVE

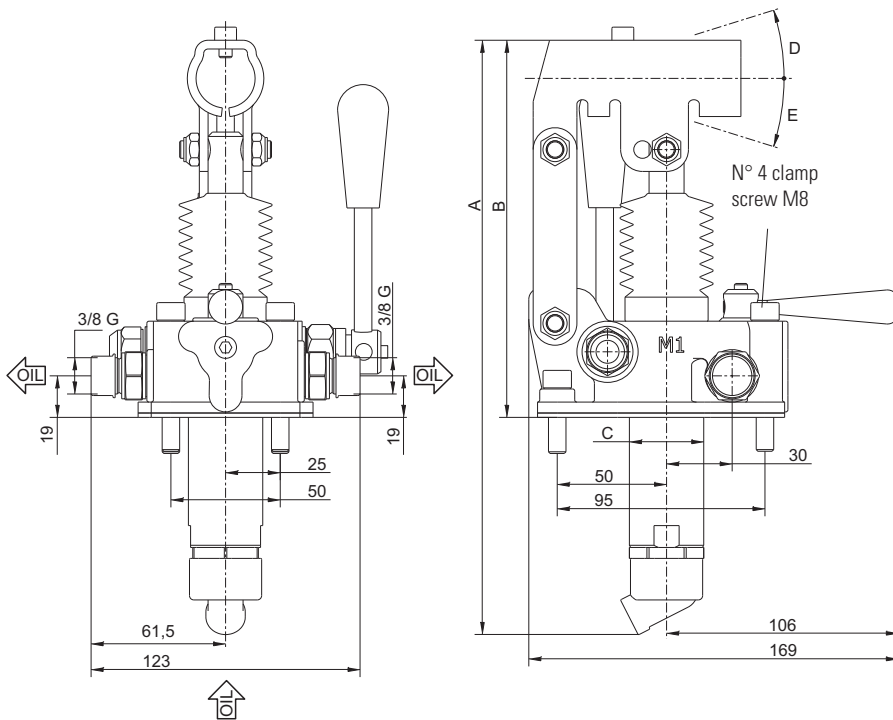

With 4/3 flow divider closed centre
 With release lever
 With pressure relief valve
 Double acting hand pump for a double acting cylinder
 For fixing to tank

Specifications:

- Cast iron body
- Piston treated with Niploy
- White zinc plated support lever
- Lever connection $\varnothing 27$
- White zinc plated external parts
- Standard colour black
- Oil tank mounting kit included
- Pressure relief valve standard setting: 100 bar (others settings upon request).

Ordering code				A mm	B mm	C mm	D °	E °	Nominal displac. cm ³	Actual displac. cm ³	Pressure BAR		Mass kg	Lever
Type	Tank	Variante	No. serie								Optimal	Max		
PMI06	S** (pag. 25)	06	2	253	166	34	26	31	6	6,970	420	500	3,40	pag. 32
PMI12				253	166	34	26	31	12	12,095	220	380	3,40	
PMI25				273	172	34	30	30	25	25,280	120	350	3,45	
PMI45				283	172	40	45	33	45	44,532	80	280	3,50	

EFFORT DIAGRAM

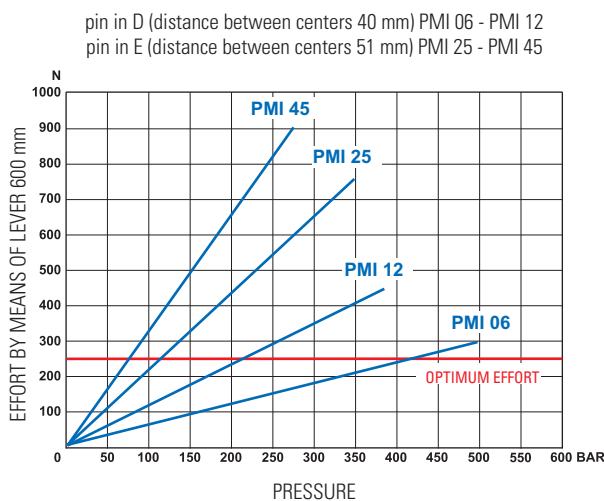

HYDRAULIC DIAGRAM

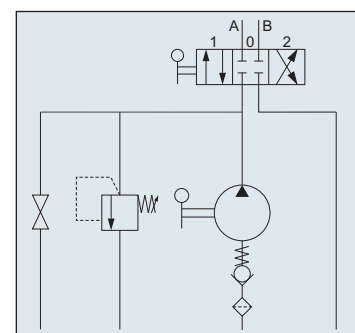

HAND PUMP WITH 4/3 FLOW DIVIDER, DUAL PILOT CHECK VALVE AND BRAKES

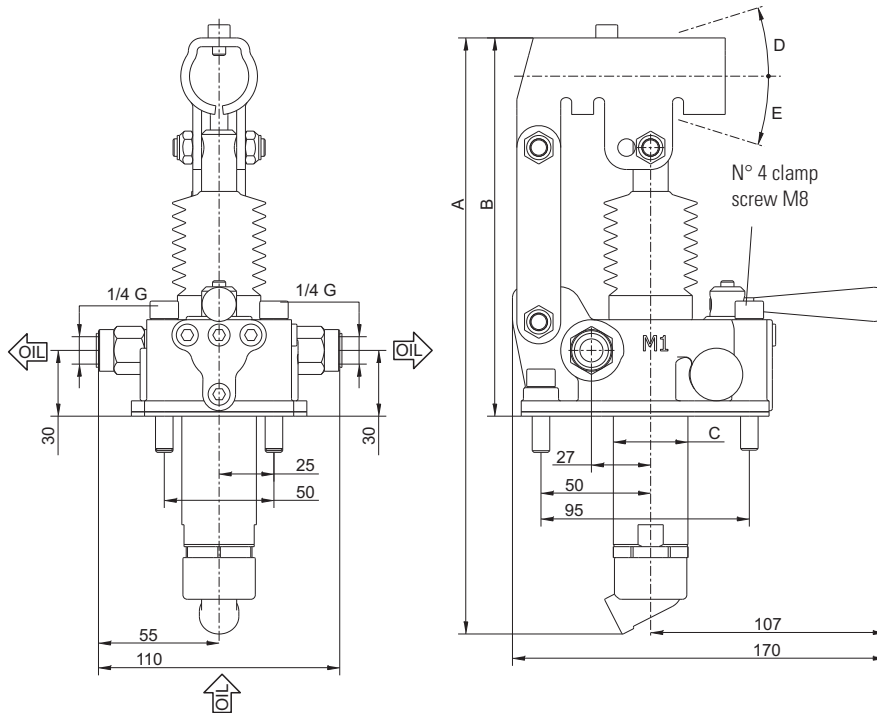

With 4/3 flow divider
With dual pilot check valve
With brakes
Double acting hand pump for a double acting cylinder
For fixing to tank

Specifications:

- Cast iron body
- Piston treated with Niploy
- White zinc plated support lever
- Lever connection Ø 27
- White zinc plated external parts
- Standard colour black
- Oil tank mounting kit included
- With hydraulic brakes to operate under 50 bar pressure.

Ordering code				A mm	B mm	C mm	D °	E °	Nominal displac. cm ³	Actual displac. cm ³	Pressure BAR		Mass kg	Lever
Type	Tank	Variante	No. serie								Optimal	Max		
PMB06	S** (pag. 25)	00	2	253	166	34	26	31	6	6,970	420	500	3,40	pag. 32
PMB12				253	166	34	26	31	12	12,095	220	380	3,40	
PMB25				273	172	34	30	30	25	25,280	120	350	3,45	
PMB45				283	172	40	45	33	45	44,532	80	280	3,50	

EFFORT DIAGRAM

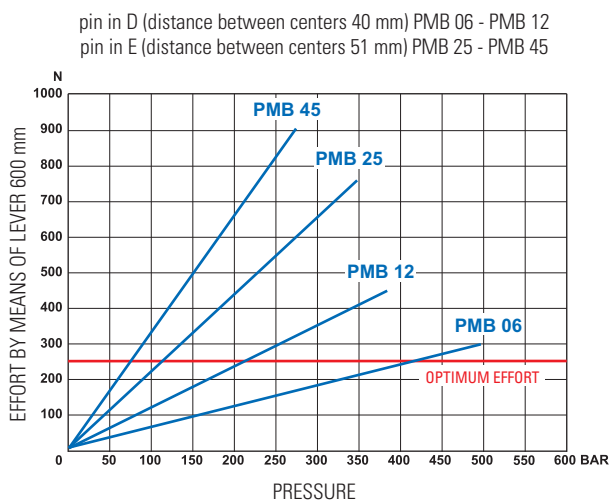

HYDRAULIC DIAGRAM

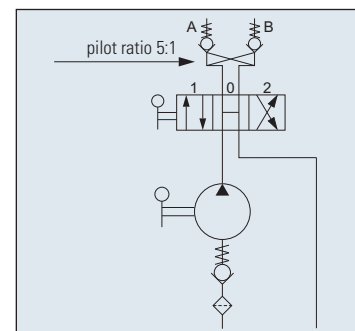

HAND PUMP WITH 4/3 FLOW DIVIDER, DUAL PILOT CHECK VALVE, BRAKES AND PRESSURE RELIEF VALVE IN "A"

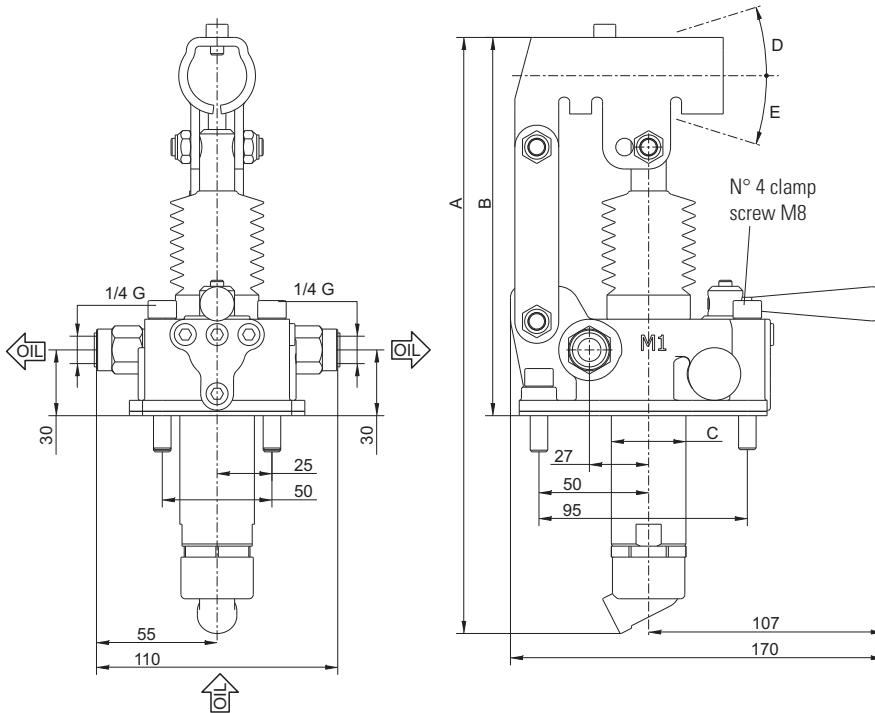

With 4/3 flow divider
With dual pilot check valve
With brakes
With pressure relief valve in "A"
Double acting hand pump for a double acting cylinder
For fixing to tank

Specifications:

- Cast iron body
- Piston treated with Niploy
- White zinc plated support lever
- Lever connection Ø 27
- White zinc plated external parts
- Standard colour black
- Oil tank mounting kit included
- With hydraulic brakes to operate under 50 bar pressure
- Pressure relief valve standard setting: 100 bar (others settings upon request).

Ordering code				A mm	B mm	C mm	D °	E °	Nominal displac. cm ³	Actual displac. cm ³	Pressure BAR		Mass kg	Lever
Type	Tank	Variante	No. serie								Optimal	Max		
PMB06	S** (pag. 25)	07	2	253	166	34	26	31	6	6,970	420	500	3,40	pag. 32
PMB12				253	166	34	26	31	12	12,095	220	380	3,40	
PMB25				273	172	34	30	30	25	25,280	120	350	3,45	
PMB45				283	172	40	45	33	45	44,532	80	280	3,50	

EFFORT DIAGRAM

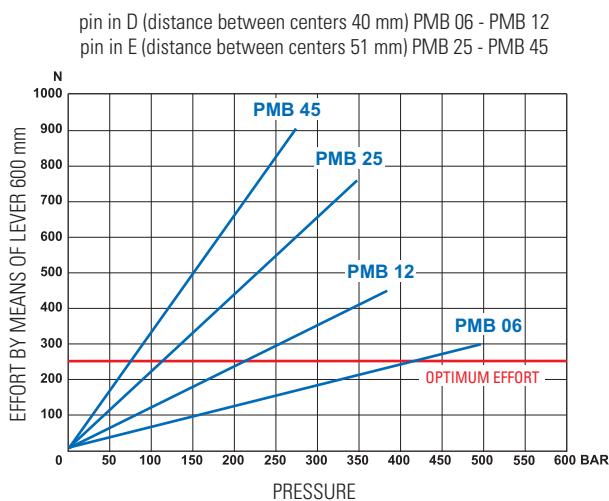

HYDRAULIC DIAGRAM

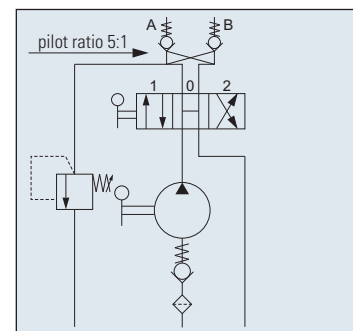

HAND PUMP WITH 4/3 FLOW DIVIDER, DUAL PILOT CHECK VALVE, BRAKES AND PRESSURE RELIEF VALVE IN "B"

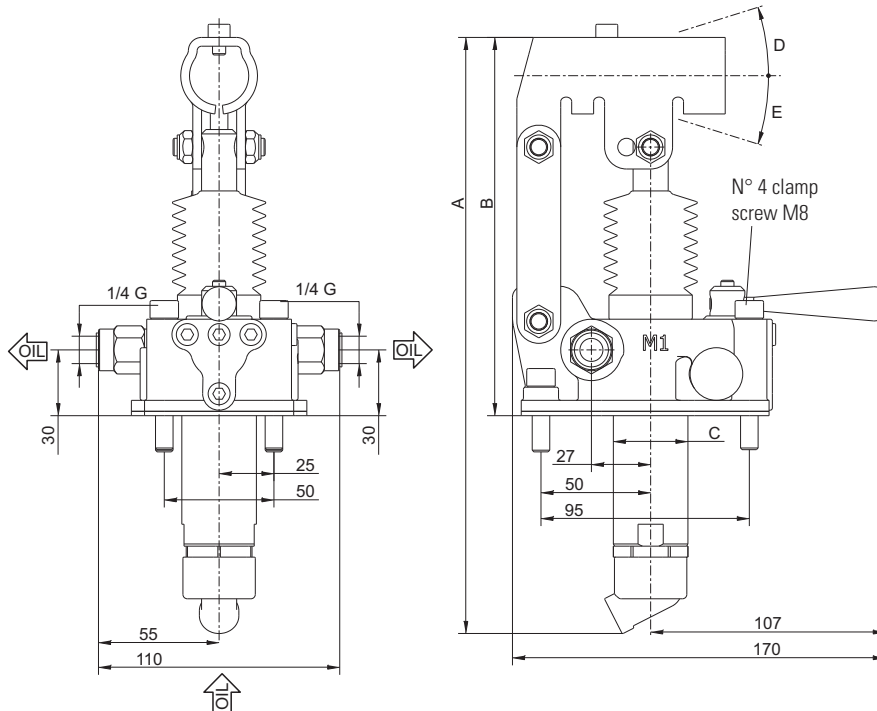

With 4/3 flow divider
With dual pilot check valve
With brakes
With pressure relief valve in "B"
Double acting hand pump for a double acting cylinder
For fixing to tank

Specifications:

- Cast iron body
- Piston treated with Niploy
- White zinc plated support lever
- Lever connection Ø 27
- White zinc plated external parts
- Standard colour black
- Oil tank mounting kit included
- With hydraulic brakes to operate under 50 bar pressure
- Pressure relief valve standard setting: 100 bar (others settings upon request).

Ordering code				A mm	B mm	C mm	D °	E °	Nominal displac. cm ³	Actual displac. cm ³	Pressure BAR		Mass kg	Lever
Type	Tank	Variat	No. serie								Optimal	Max		
PMB06	S** (pag. 25)	08	2	253	166	34	26	31	6	6,970	420	500	3,40	pag. 32
PMB12				253	166	34	26	31	12	12,095	220	380	3,40	
PMB25				273	172	34	30	30	25	25,280	120	350	3,45	
PMB45				283	172	40	45	33	45	44,532	80	280	3,50	

EFFORT DIAGRAM

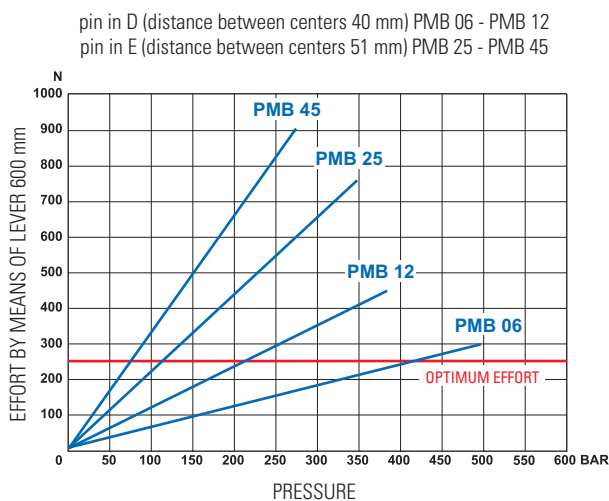

HYDRAULIC DIAGRAM

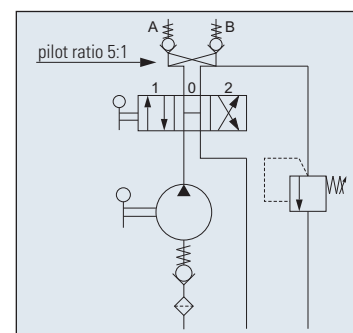

HAND PUMP WITH 4/3 FLOW DIVIDER, DUAL PILOT CHECK VALVE, BRAKES AND PRESSURE RELIEF VALVE IN "A" AND "B"

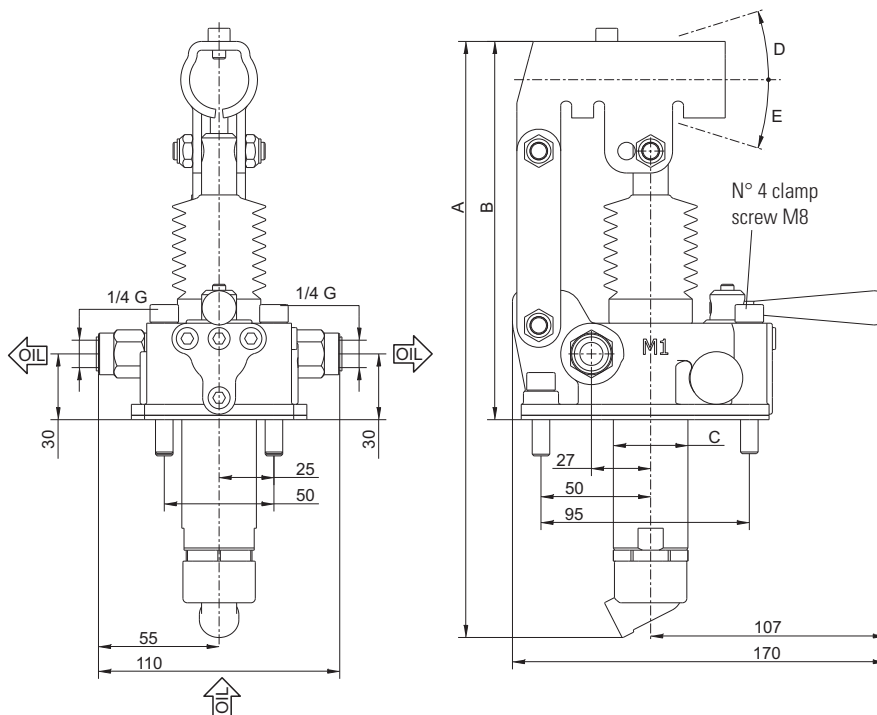

With 4/3 flow divider
With dual pilot check valve in "A" and "B"
With brakes
With pressure relief valve
Double acting hand pump for a double acting cylinder
For fixing to tank

Specifications:

- Cast iron body
- Piston treated with Niploy
- White zinc plated support lever
- Lever connection Ø 27
- White zinc plated external parts
- Standard colour black
- Oil tank mounting kit included
- With hydraulic brakes to operate under 50 bar pressure
- Pressure relief valve standard setting: 100 bar (others settings upon request).

Ordering code				A mm	B mm	C mm	D °	E °	Nominal displac. cm ³	Actual displac. cm ³	Pressure BAR		Mass kg	Lever
Type	Tank	Variante	No. serie								Optimal	Max		
PMB06	S** (pag. 25)	09	2	253	166	34	26	31	6	6,970	420	500	3,40	pag. 32
PMB12				253	166	34	26	31	12	12,095	220	380	3,40	
PMB25				273	172	34	30	30	25	25,280	120	350	3,45	
PMB45				283	172	40	45	33	45	44,532	80	280	3,50	

EFFORT DIAGRAM

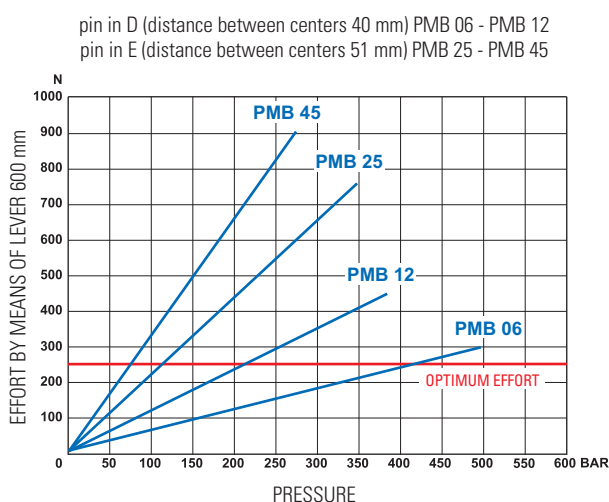

HYDRAULIC DIAGRAM

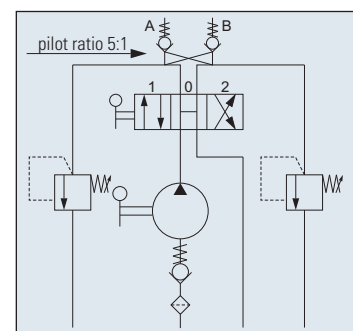

SINGLE ACTING HAND PUMP WITH RELEASE HAND KNOB

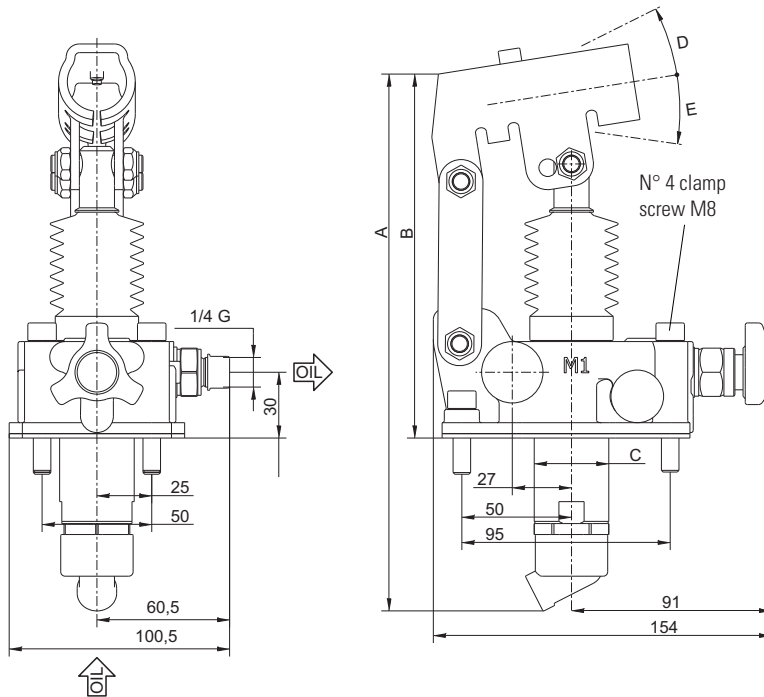

With release hand knob
Single acting hand pump for a single acting cylinder
For fixing to tank

Specifications:

- Cast iron body
- Piston treated with Niploy
- White zinc plated support lever
- Lever connection Ø 27
- White zinc plated external parts
- Standard colour black
- Oil tank mounting kit included.

Ordering code				A mm	B mm	C mm	D °	E °	Nominal displac. cm ³	Actual displac. cm ³	Pressure BAR		Mass kg	Lever
Type	Tank	Variant	No. serie								Optimal	Max		
1PMS20	S** (pag. 25)	00	2	249	167	34	35	29	20	20,527	80	240	3,10	pag. 32
1PMS30				252	167	34	38	26	30	30,262	60	185	3,20	
1PMS40				252	167	40	38	26	40	40,290	40	160	3,30	

EFFORT DIAGRAM

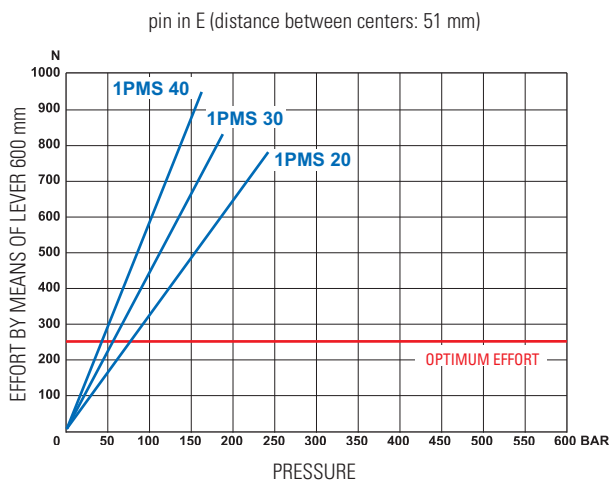

HYDRAULIC DIAGRAM

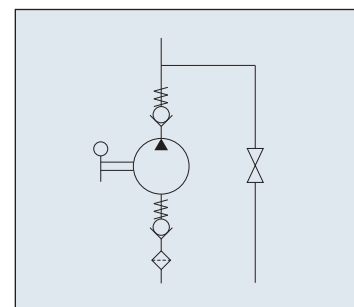

SINGLE ACTING HAND PUMP WITH RELEASE HAND KNOB AND PRESSURE RELIEF VALVE

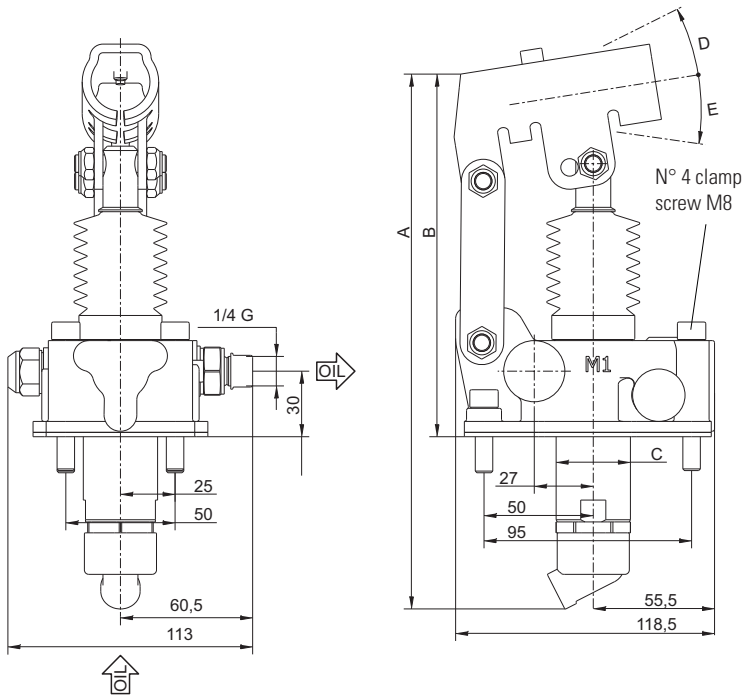

With release hand knob
 With pressure relief valve
 Single acting hand pump for a single acting cylinder
 For fixing to tank

Specifications:

- Cast iron body
- Piston treated with Niploy
- White zinc plated support lever
- Lever connection $\varnothing 27$
- White zinc plated external parts
- Standard colour black
- Oil tank mounting kit included
- Pressure relief valve standard setting: 100 bar (others settings upon request).

Type	Ordering code			A mm	B mm	C mm	D °	E °	Nominal displac. cm ³	Actual displac. cm ³	Pressure BAR		Mass kg	Lever
	Tank	Variat	No. serie								Optimal	Max		
1PMS20	S** (pag. 25)	02	2	249	167	34	35	29	20	20,527	80	240	3,10	pag. 32
1PMS30				252	167	34	38	26	30	30,262	60	185	3,20	
1PMS40				252	167	40	38	26	40	40,290	40	160	3,30	

EFFORT DIAGRAM

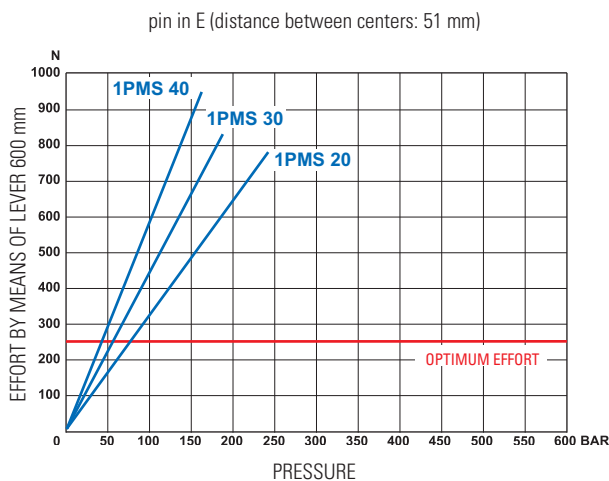

HYDRAULIC DIAGRAM

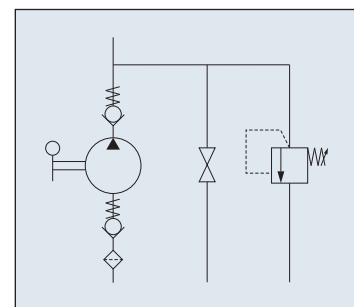

SINGLE ACTING HAND PUMP WITHOUT RELEASE HAND KNOB

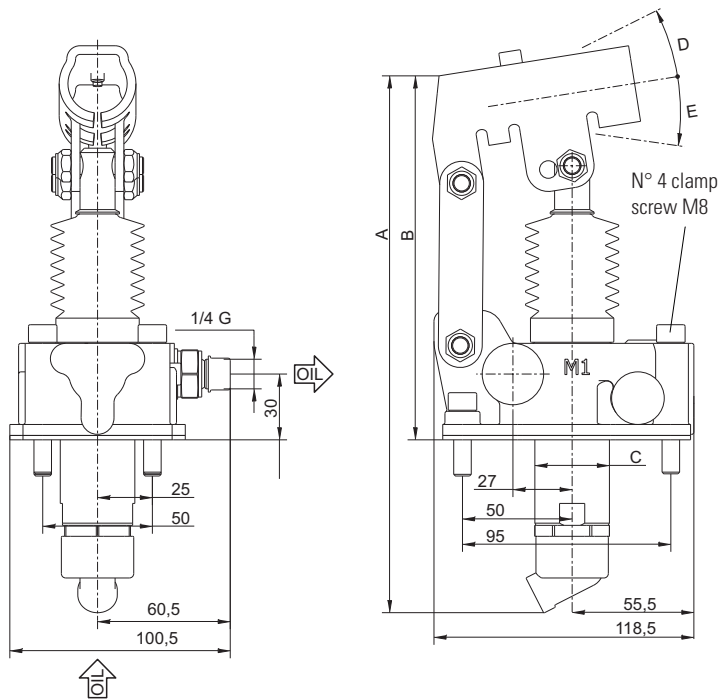

Without release hand knob
Single acting hand pump for a single acting cylinder
For fixing to tank

Specifications:

- Cast iron body
- Piston treated with Niploy
- White zinc plated support lever
- Lever connection Ø 27
- White zinc plated external parts
- Standard colour black
- Oil tank mounting kit included

Ordering code				A mm	B mm	C mm	D °	E °	Nominal displac. cm ³	Actual displac. cm ³	Pressure BAR		Mass kg	Lever
Type	Tank	Variante	No. serie								Optimal	Max		
1PMS20	S** (pag. 25)	03	2	249	167	34	35	29	20	20,527	80	240	3,10	pag. 32
1PMS30				252	167	34	38	26	30	30,262	60	185	3,20	
1PMS40				252	167	40	38	26	40	40,290	40	160	3,30	

EFFORT DIAGRAM

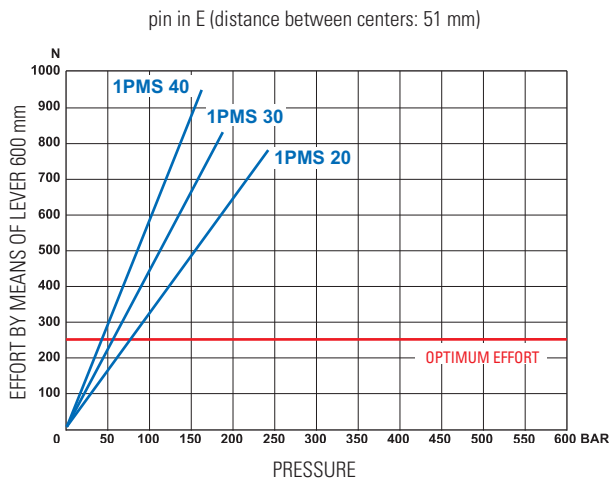

HYDRAULIC DIAGRAM

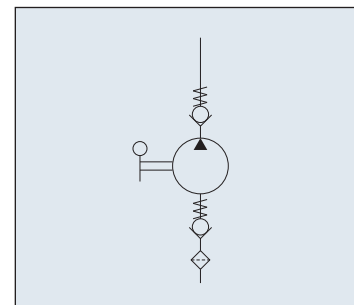

SINGLE ACTING HAND PUMP WITH RELEASE HAND KNOB

With release hand knob
 Single acting hand pump for a single acting cylinder
 For fixing to tank

Specifications:

- Cast iron body
- Piston treated with Niploy
- Iron cast support lever
- Lever connection $\varnothing 20$
- White zinc plated external parts
- Standard colour black
- Oil tank mounting kit included

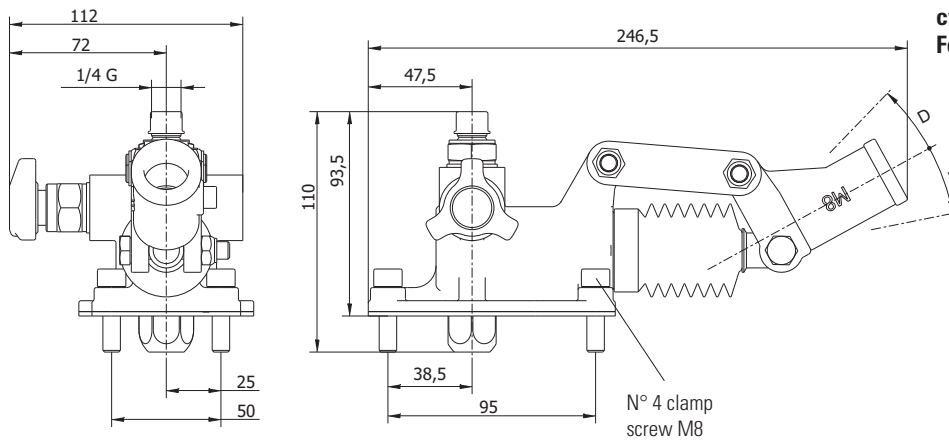

Ordering code				D °	E °	Nominal displac. cm ³	Actual displac. cm ³	Pressure BAR		Mass kg	Lever
Type	Tank	Variant	No. serie					Optimal	Max		
2PMS08	S** (pag. 25)	00	2	30	26	8	8,042	180	360	3,20	pag. 32
2PMS15				30	26	15	15,205	110	350	3,20	

EFFORT DIAGRAM

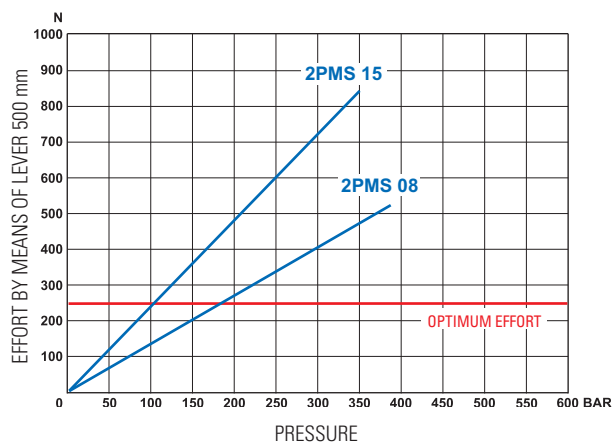

HYDRAULIC DIAGRAM

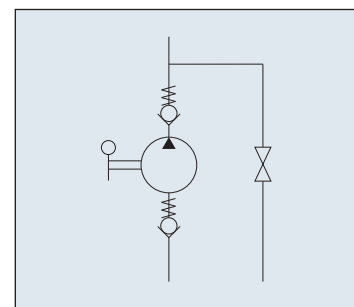

SINGLE ACTING HAND PUMP WITH RELEASE HAND KNOB AND PRESSURE RELIEF VALVE

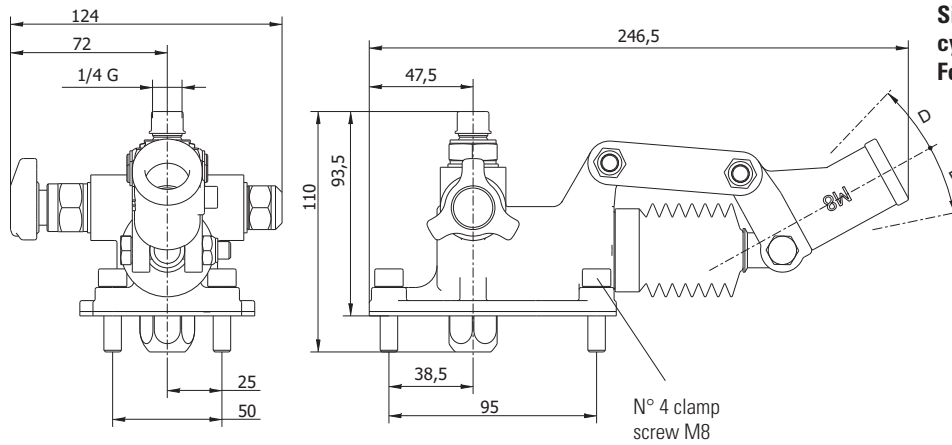

With release hand knob
 With pressure relief valve
 Single acting hand pump for a single acting cylinder
 For fixing to tank

Specifications:

- Cast iron body
- Piston treated with Niploy
- Iron cast support lever
- Lever connection $\varnothing 20$
- White zinc plated external parts
- Standard colour black
- Oil tank mounting kit included
- Pressure relief valve standard setting: 100 bar (others settings upon request).

Ordering code				D °	E °	Nominal displac. cm ³	Actual displac. cm ³	Pressure BAR		Mass kg	Lever
Type	Tank	Variant	No. serie					Optimal	Max		
2PMS08	S** (pag. 25)	02	2	30	26	8	8,042	180	360	3,20	pag. 32
2PMS15				30	26	15	15,205	110	350	3,20	

EFFORT DIAGRAM

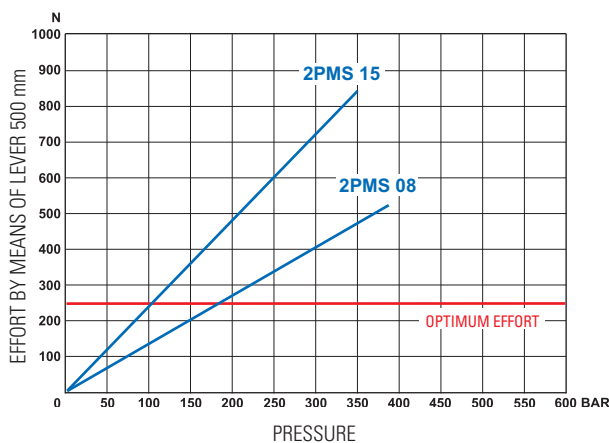

HYDRAULIC DIAGRAM

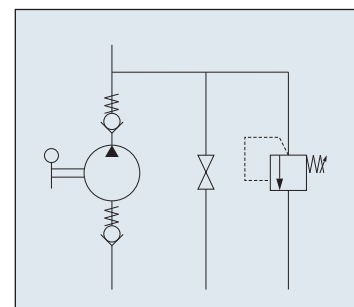

SINGLE ACTING HAND PUMP WITHOUT RELEASE HAND KNOB

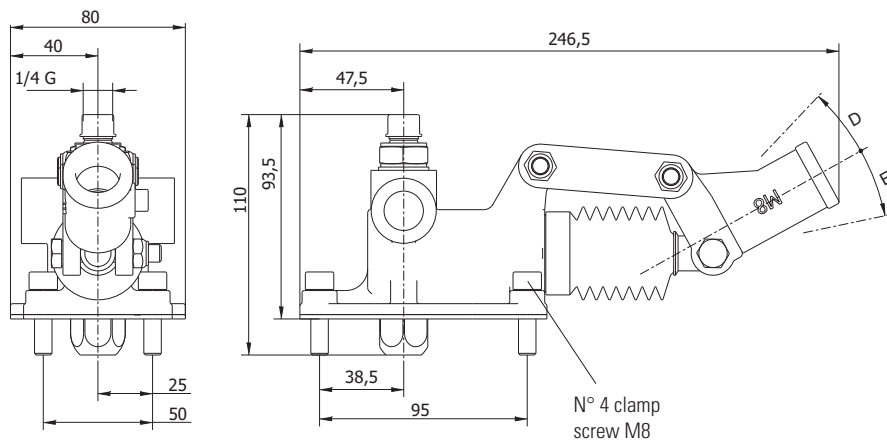

Without release hand knob
 Single acting hand pump for a single acting cylinder
 For fixing to tank

Specifications:

- Cast iron body
- Piston treated with Niploy
- Iron cast support lever
- Lever connection $\varnothing 20$
- White zinc plated external parts
- Standard colour black
- Oil tank mounting kit included

Ordering code				D °	E °	Nominal displac. cm ³	Actual displac. cm ³	Pressure BAR		Mass kg	Lever
Type	Tank	Variant	No. serie					Optimal	Max		
2PMS08	S** (pag. 25)	03	2	30	26	8	8,042	180	360	3,20	pag. 32
2PMS15				30	26	15	15,205	110	350	3,20	

EFFORT DIAGRAM

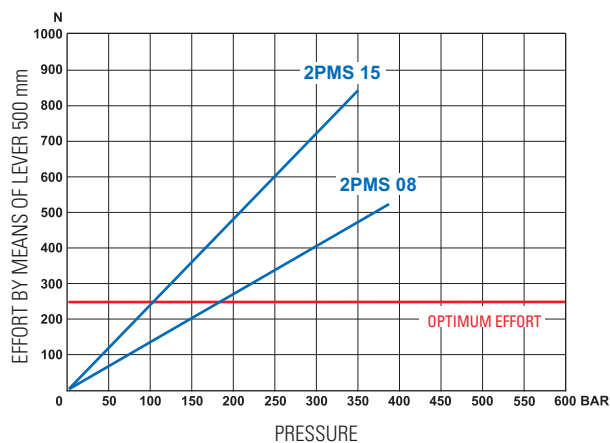

HYDRAULIC DIAGRAM

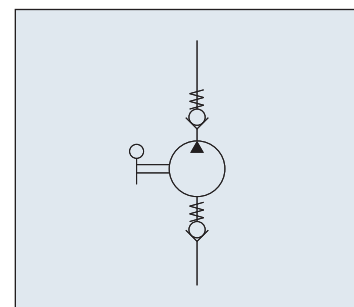

PAINTED STEEL OIL TANKS FOR HAND PUMPS

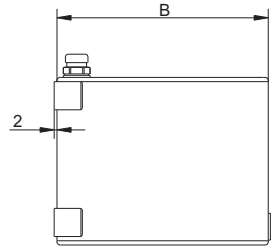
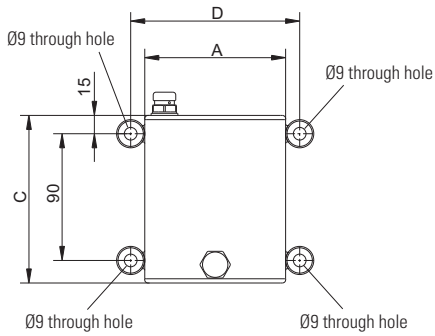

Specifications:

- Suction pipe included
- Breather cap 1/4 G
- Release cap 1/4 G
- Standard colour black

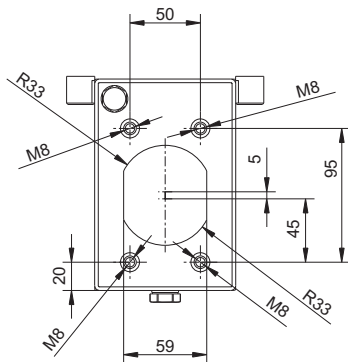

Ordering code	Capacity liters	A mm	B mm	C mm	D mm	Mass kg	Suction pipe	Tank kit
S01	1	100	150	120	120	2,2	Ø10 x 85 mm	SPM010001
S02	2	100	150	185	120	3,2	Ø10 x 114 mm	SPM020001
S03	3	100	150	255	120	3,7	Ø10 x 180 mm	SPM030001

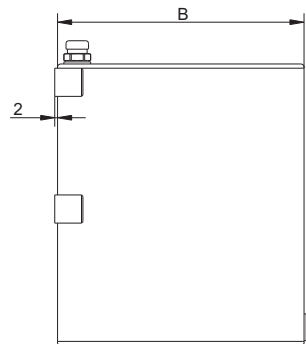
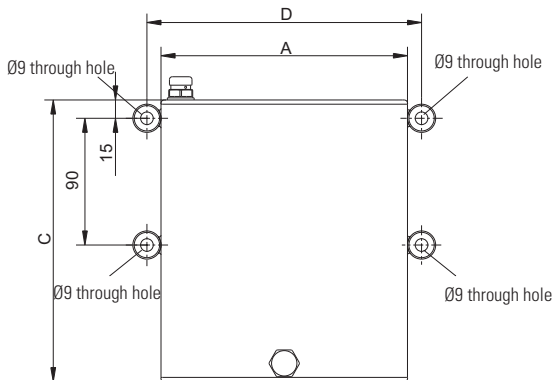

Specifications:

- Suction pipe included
- Breather cap 1/4 G
- Release cap 1/4 G
- Standard colour black

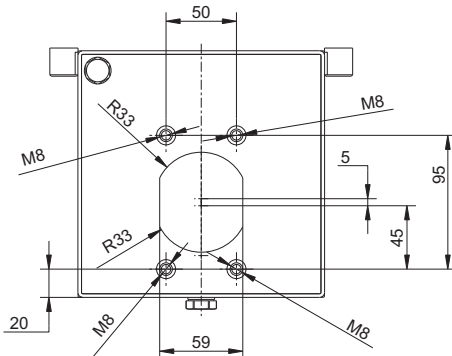

Ordering code	Capacity liters	A mm	B mm	C mm	D mm	Mass kg	Suction pipe	Tank kit
S05	5	175	175	200	195	5,3	Ø10 x 156 mm	SPM050001
S07	7	175	175	275	195	6,6	Ø10 x 215 mm	SPM070001
S10	10	175	175	380	195	8,3	Ø10 x 325 mm	SPM100001

HAND PUMP WITH RELEASE HAND KNOB

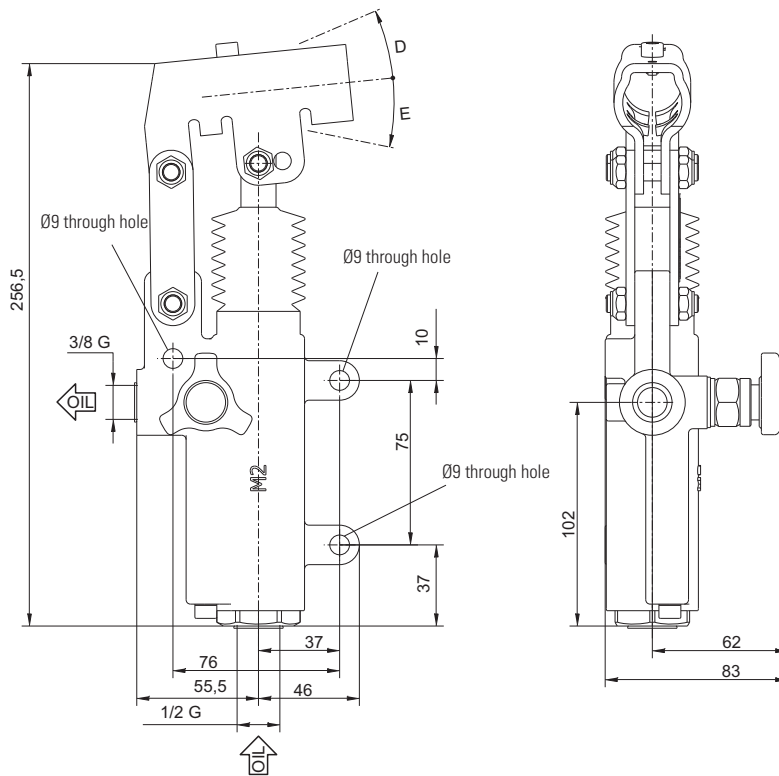

With release hand knob
Double acting hand pump for single acting cylinder
For fixing to wall

Specifications:

- Cast iron body
- Piston treated with Niploy
- White zinc plated support lever
- Lever connection Ø 27
- White zinc plated external parts
- Standard colour black

Ordering code			D °	E °	Nominal displac. cm ³	Actual displac. cm ³	Pressure BAR		Mass kg	Lever
Type	Variant	No. serie					Optimal	Max		
PM020	00	2	32	30	20	20,090	150	350	2,65	pag. 32

EFFORT DIAGRAM

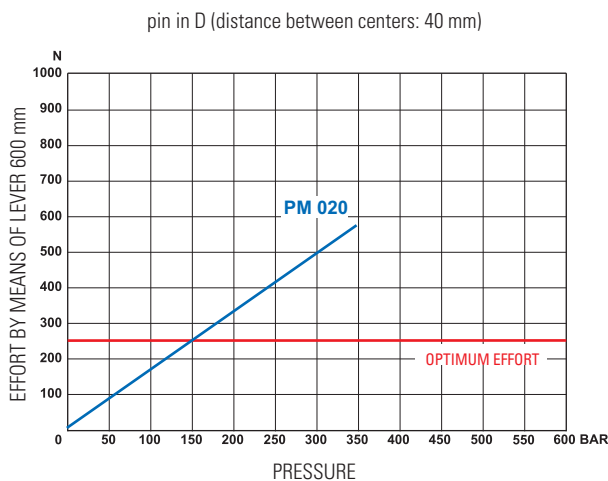

HYDRAULIC DIAGRAM

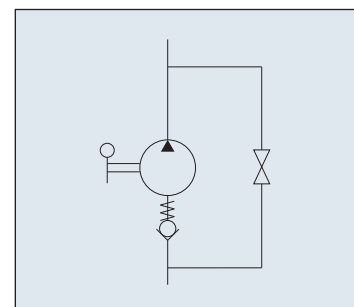

HAND PUMP WITHOUT RELEASE HAND KNOB

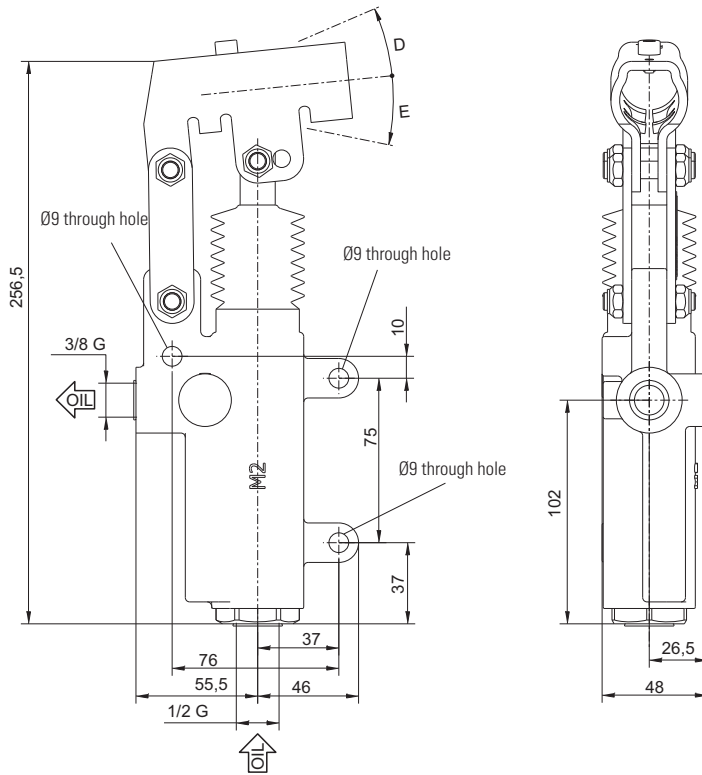

Without release hand knob
Double acting hand pump for single acting cylinder
For fixing to wall

Specifications:

- Cast iron body
- Piston treated with Niploy
- White zinc plated support lever
- Lever connection Ø 27
- White zinc plated external parts
- Standard colour black

Ordering code			D °	E °	Nominal displac. cm ³	Actual displac. cm ³	Pressure BAR		Mass kg	Lever
Type	Variant	No. serie					Optimal	Max		
PM020	03	2	32	30	20	20,090	150	350	2,65	pag. 32

EFFORT DIAGRAM

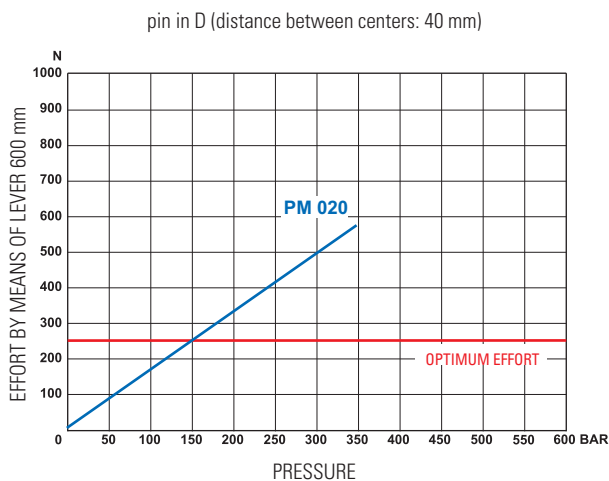

HYDRAULIC DIAGRAM

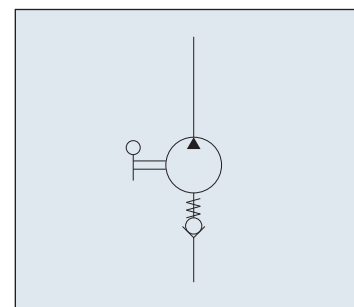

HAND PUMP WITH PRESSURE RELIEF VALVE WITHOUT RELEASE HAND KNOB

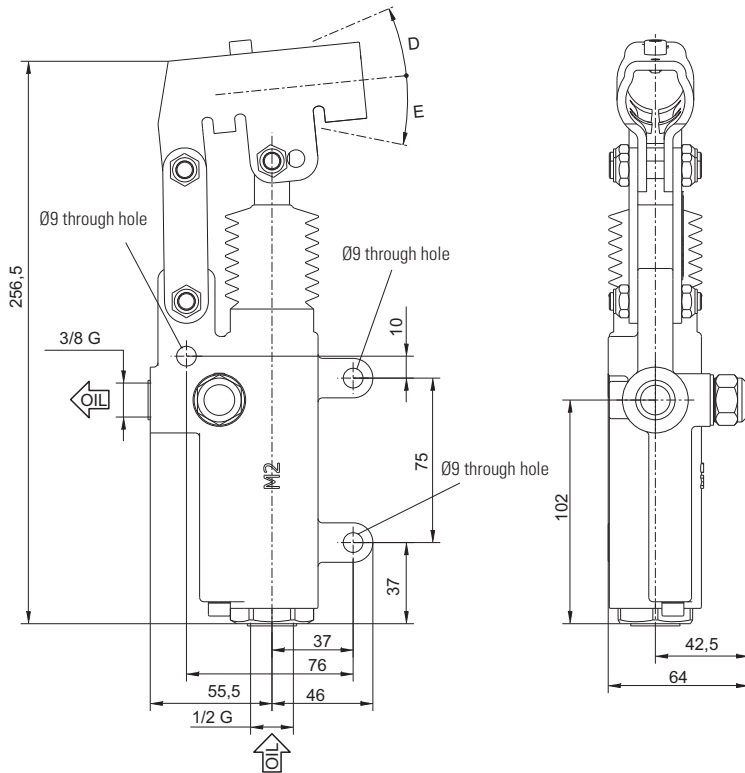

With pressure relief valve
Without release hand knob
Double acting hand pump for single acting cylinder
For fixing to wall

Specifications:

- Cast iron body
- Piston treated with Niploy
- White zinc plated support lever
- Lever connection Ø 27
- White zinc plated external parts
- Standard colour black
- Pressure relief valve standard setting: 100 bar (others settings upon request)

Ordering code			D °	E °	Nominal displac. cm ³	Actual displac. cm ³	Pressure BAR		Mass kg	Lever
Type	Variant	No. serie					Optimal	Max		
PM020	10	2	32	30	20	20,090	150	350	2,65	pag. 32

EFFORT DIAGRAM

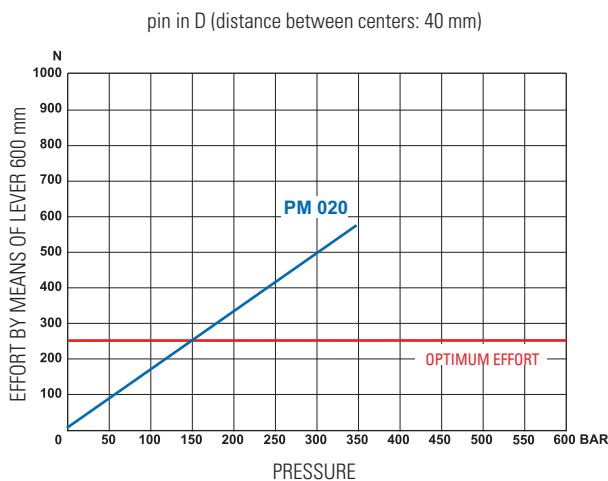

HYDRAULIC DIAGRAM

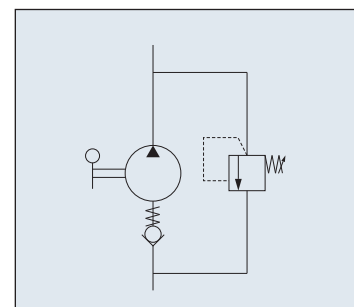

HAND PUMP WITH RELEASE HAND KNOB

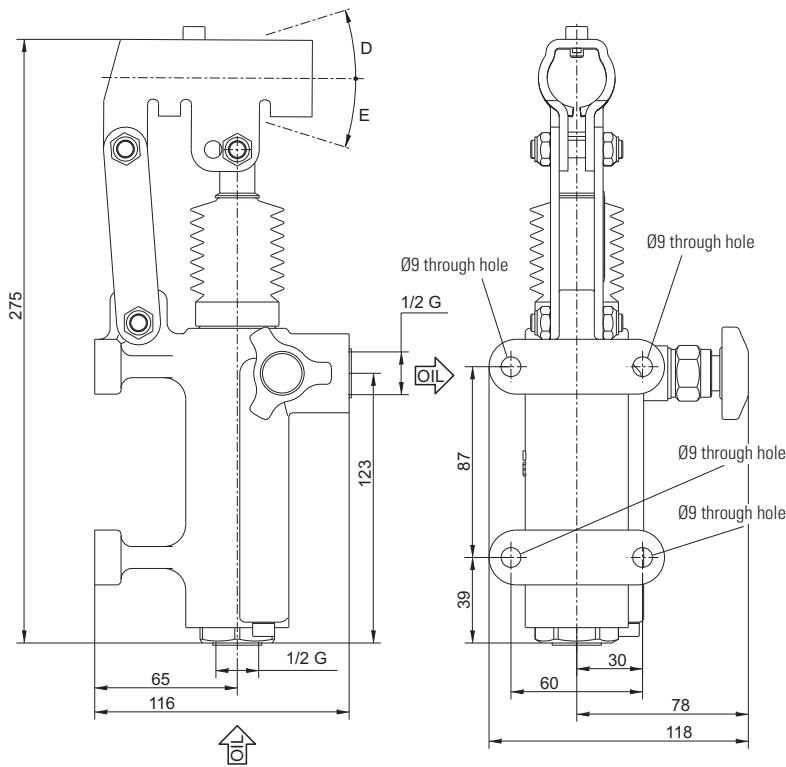

Without release hand knob
Double acting hand pump for single acting cylinder
For fixing to wall

Specifications:

- Cast iron body
- Piston treated with Niploy
- White zinc plated support lever
- Lever connection Ø 27
- White zinc plated external parts
- Standard colour black

Ordering code			D °	E °	Nominal displac. cm ³	Actual displac. cm ³	Pressure BAR		Mass kg	Lever
Type	Variant	No. serie					Optimal	Max		
PM050	00	2	38	37	50	43,825	80	280	3,40	pag. 32

EFFORT DIAGRAM

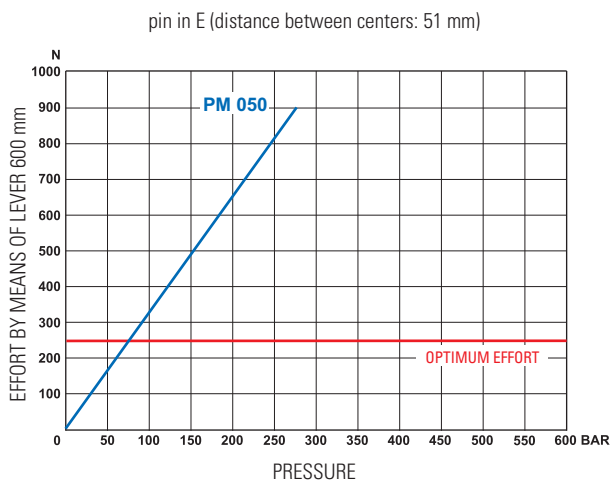

HYDRAULIC DIAGRAM

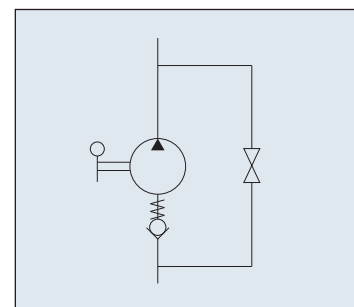

HAND PUMP WITHOUT RELEASE HAND KNOB

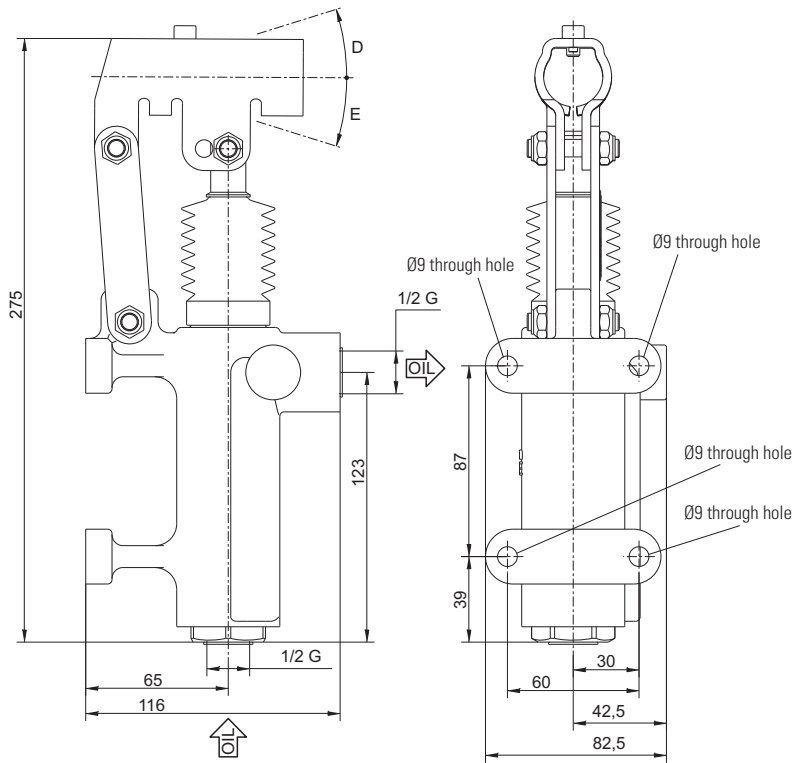

Without release hand knob
Double acting hand pump for single acting cylinder
For fixing to wall

Specifications:

- Cast iron body
- Piston treated with Niploy
- White zinc plated support lever
- Lever connection Ø 27
- White zinc plated external parts
- Standard colour black.

Ordering code			D °	E °	Nominal displac. cm ³	Actual displac. cm ³	Pressure BAR		Mass kg	Lever
Type	Variant	No. serie					Optimal	Max		
PM050	03 (1)	2	38	37	50	43,825	80	280	3,40	pag. 32

EFFORT DIAGRAM

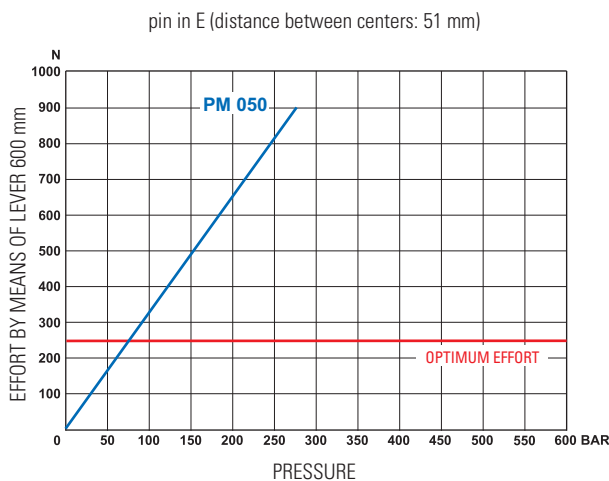

HYDRAULIC DIAGRAM

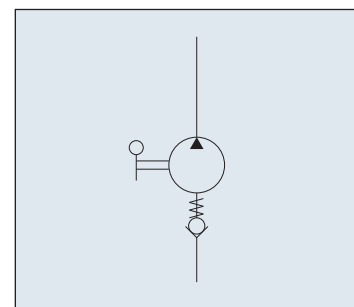

HAND PUMP WITH PRESSURE RELIEF VALVE WITHOUT RELEASE HAND KNOB

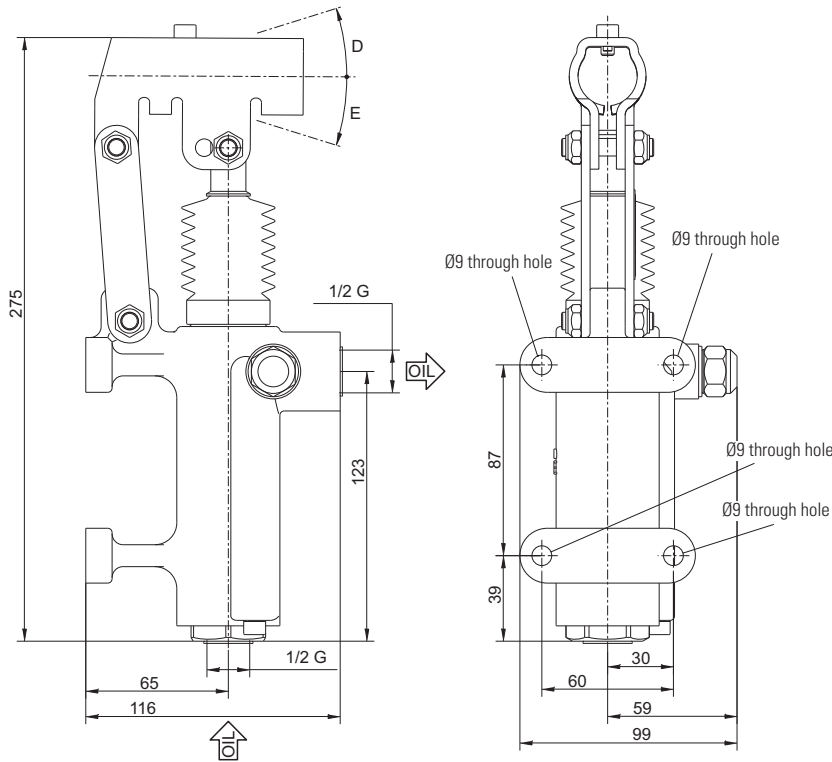

Without release hand knob
With pressure relief valve
Double acting hand pump for single acting cylinder
For fixing to wall

Specifications:

- Cast iron body
- Piston treated with Niploy
- White zinc plated support lever
- Lever connection Ø 27
- White zinc plated external parts
- Standard colour black
- Pressure relief valve standard setting: 100 bar (others settings upon request).

Ordering code			D °	E °	Nominal displac. cm ³	Actual displac. cm ³	Pressure BAR		Mass kg	Lever
Type	Variant	No. serie					Optimal	Max		
PM050	10	2	38	37	50	43,825	80	280	3,40	pag. 32

EFFORT DIAGRAM

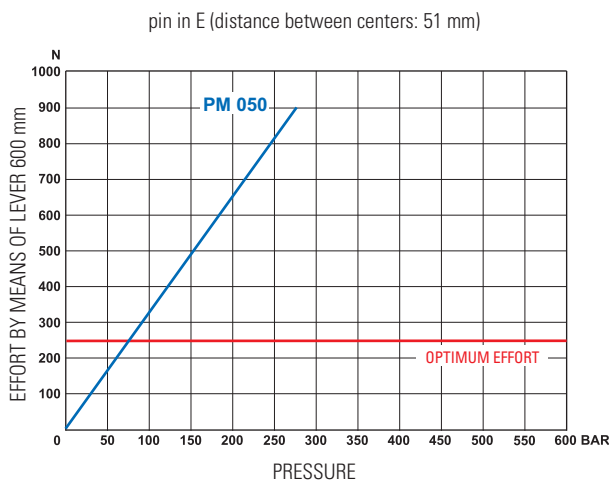

HYDRAULIC DIAGRAM

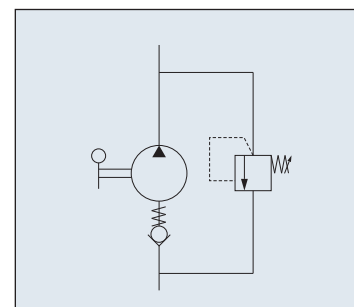

LEVER

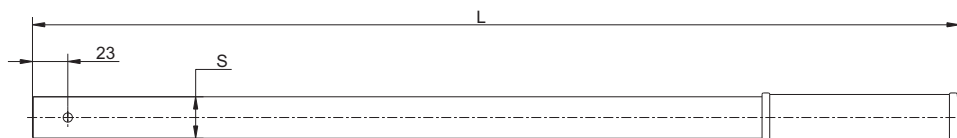

Specifications:

- Black hand grip
- White zinc plated steel lever

Ordering code	S mm	L mm	Mass kg	For pump
LPM270400D	27	400	0,6	PM - PMI - PMB - 1PMS PM020 - PM050
LPM270600D	27	600	0,9	
LPM270850D	27	850	1,2	
LPM200500D	20	500	0,4	2PMS

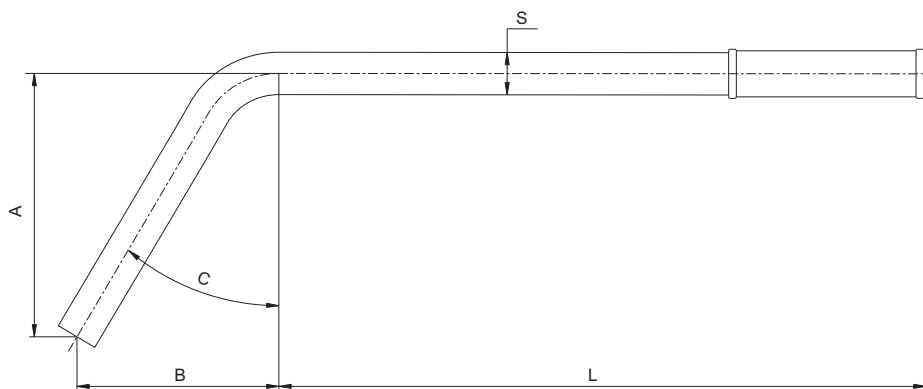

Specifications:

- Black hand grip
- White zinc plated steel lever

Ordering code	A mm	B mm	C mm	S mm	L mm	Mass kg	For pump
LPM270600P	140	100	31	27	415	0,9	PM - PMI - PMB - 1PMS - PM020 - PM050

HAND PUMP

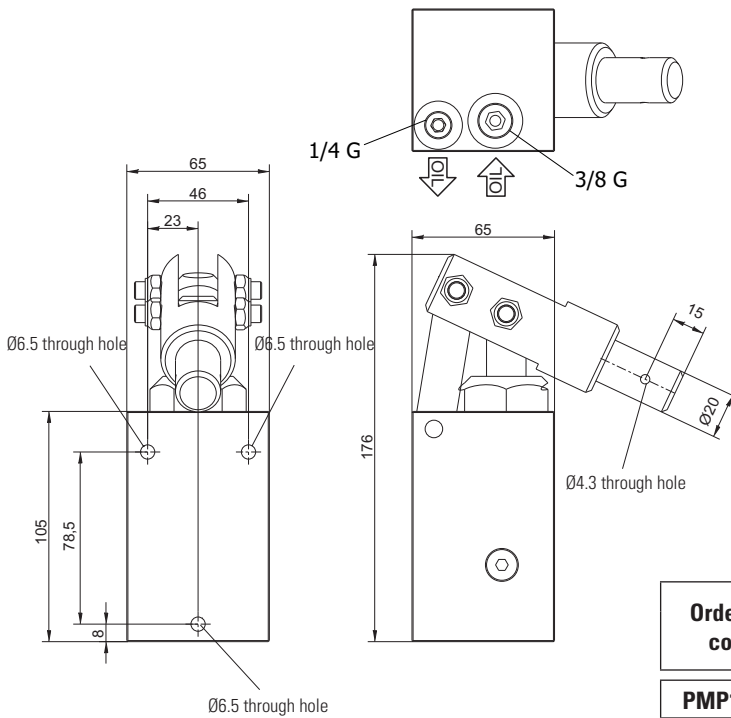

Without release hand knob
Double acting hand pump for a single acting cylinder
For fixing to a wall!

Specifications:

- Aluminium body
- Piston treated with Niploy
- White zinc plated support lever
- Lever connection Ø 20
- White zinc plated external parts

Ordering code	Nominal displac. cm ³	Actual displac. cm ³	Pressure BAR		Mass kg
			Optimal	Max	
PMP12003	12	12,265	100	300	2,11

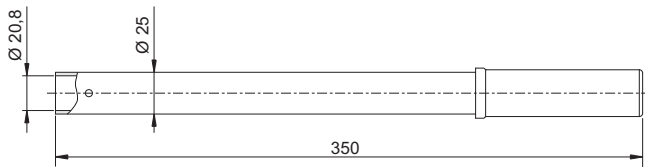

Ordering code
LPM250350D

Lever for PMP12 pump:

- Black hand grip
- White zinc plated steel lever

EFFORT DIAGRAM

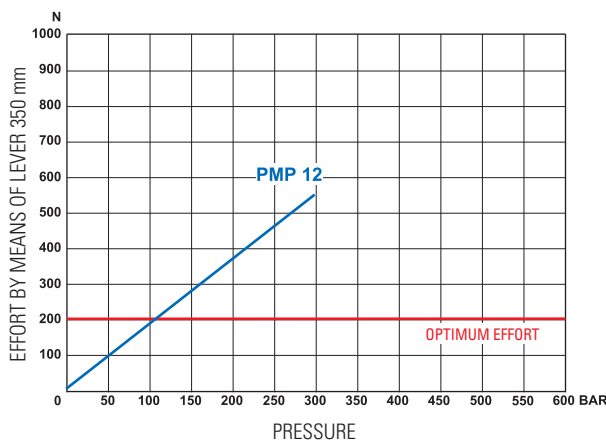

HYDRAULIC DIAGRAM

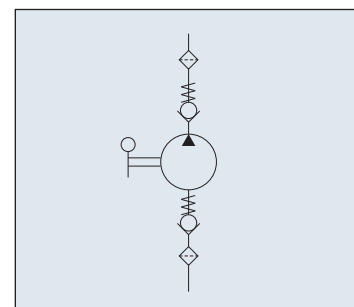



BREVINI[®]

Motion Systems



OIL SOLUTIONS

1800-OILSOL
1800-645765

<https://oilsolutions.com.au/>

sales@oilsolutions.com.au

Code DOC00069 - Rev. 03

Dana Motion Systems Italia S.r.l.

Fluid Power Division

Sede operativa: Via Giulio Natta 1, 42124 Reggio Emilia - Italy
Tel: +39.0522.270711 - Fax: +39.0522.505856

Sede legale: Via Luciano Brevini 1/A, 42124 Reggio Emilia - Italy
Tel: +39.0522.9281 - Fax: +39.0522.928300

www.dana.com/brevini - dana.re@dana.com

