

# Electrical amplifier module for the flow control of a variable displacement axial piston pump with electrical position feedback

**RE 29763/12.06**  
Replaces: 12.02

1/8

Type VT 11019

Component series 1X



H5316\_d

## Table of contents

Contents	Page
Features	1
Ordering code	2
Functional description	2
Technical data	3
Characteristics in the case of a fault	4
Block circuit diagram / connection allocation VT 11019	4
Terminal connections	5
Unit dimensions	5
Engineering / maintenance guidelines / additional information	6

## Features

- The VT 11019 amplifier module is used for controlling the flow of a variable displacement axial piston pump with electrical position feedback and FE control (type A10VSO...FE).
- Differential input
  - Adjustable ramp generator (max. ramp time 5 s)
  - Pulsed output stage
  - Controller for the valve spool position
  - Supply voltage polarity protection
  - Oscillator and demodulator for the inductive position measurements
  - Controller enable
  - LED displays: „power“ – Internal supply voltage (green)  
„H1“ – Multi-function display (orange)

## Ordering code

---

VT 11019	-1X/	*
----------	------	---

Amplifier module for the flow control of a variable displacement axial piston pump type A10VSO...FE

Further details in clear text

1X =

Component series 11 to 19 <sup>1)</sup>  
(11 to 19: unchanged technical data and connection allocation)

<sup>1)</sup> Compatible with component series 10 units, when terminal 11 has not been connected to ground (0 V) on these units (see engineering guidelines on page 4).

## Functional description

---

The amplifier module is clipped onto top hat rail such as those commonly used in electric control cabinets. The electric connections are via a terminal strip.

The amplifier module contains the electronic components for the control of a proportional solenoid. Dependent on a positive voltage signal present at the command value input the amplifier module controls the solenoid. The actual value (position of the solenoid armature) is signalled by an inductive position measuring system and compared to the externally signalled command value. Occurring differences between actual and command value are levelled out. Through the connection of a positive voltage ( $U_F > 8.5 \text{ V}$ ) at terminal 3 the controller and the output stage are enabled.

The following can be set externally via a trimming potentiometer:

- The ramp time up to approx. 5 s
- Command value reduction in a range of 0 % to 100 %
- The zero point of the position transducer

**Technical data** (for applications outside these parameters, please consult us!)

Operating voltage	$U_B$	+24 VDC +40 % -10 %
Function range:		
– Upper limiting range	$u_B(t)_{max}$	+39 V
– Lower limiting range	$u_B(t)_{min}$	+21 V
Max. current consumption	$I$	1.5 A
Fuse	$I$	2.5 A; slow blowing; after release self-activating
Inputs:		
– Differential input (command value input)	$U_e$	0 to +10 V; $R_e = 50 \text{ k}\Omega$ (standard) <sup>1)</sup>
– Enable		
• Active	$U_F$	$8.5 \text{ V} < U_F < 40 \text{ V}$
• Inactive	$U_F$	$< 6.5 \text{ V}$
– Demodulator input (positional measuring system)	$R_e$	$> 50 \text{ k}\Omega$
Ramp time (setting range)	$t$	10 ms to 5 s
Outputs:		
– Output stage		
• Solenoid current / resistance	$I_{max}$	1.3 A; $R_{(20)} = 12.7 \Omega$
• Pulse frequency	$f$	Free pulsating up to approx. 1.5 kHz
– Driver for the inductive transducer		
• Oscillator frequency	$f$	5.8 kHz $\pm 10 \%$
• Max. load capacity	$I$	30 mA
• Voltage amplitude ( $U_{SS}$ )	$U_a$	5 V per output
• Max. stroke of the position transducer	$s$	3.8 mm
– Measuring points		
• Command value w	$U_w$	0 to +5 V
• Position actual value x	$U_x$	0 to -5 V
Connection type		12-pin terminal strip
Housing dimensions (W x H x D)		40 x 79 x 85.5 mm
Permissible operating temperature range	$t$	0 to 50 °C to DIN IEC 68-2 T1, T2, T14 and T30 <sup>2)</sup>
Storage temperature	$t$	-25 to +85 °C to DIN IEC 68-2 T1 and T2 <sup>2)</sup>
Interference immunity		Class 3 to prEN 50082 T2 <sup>2)</sup>
Mechanical loadability		to DIN IEC 68-2 T6, T24 and T27 <sup>2)</sup>
Weight	$m$	0.14 kg

<sup>1)</sup> Current input on request

<sup>2)</sup> Further details on request

### Characteristics in the case of a fault

Error →	Missing enable ( $U_F < 6.5\text{ V}$ )	Cable break position transducer	Cable break current input <sup>1)</sup>
Characteristics of the electronics →	<b>E, R, A</b>	<b>E, R, A</b>	<b>S, A</b>

<sup>1)</sup> Only in special versions with a current input of 4 to 20 mA (on request)

Abbreviation meaning:

- E** = Output stage is switched off (solenoids are de-energised)
- R** = Controller is switched off
- S** = Command value is set to 0 %
- A** = Multi-function display is illuminated

### Block circuit diagram / connection allocation VT 11019 (from component series 11)

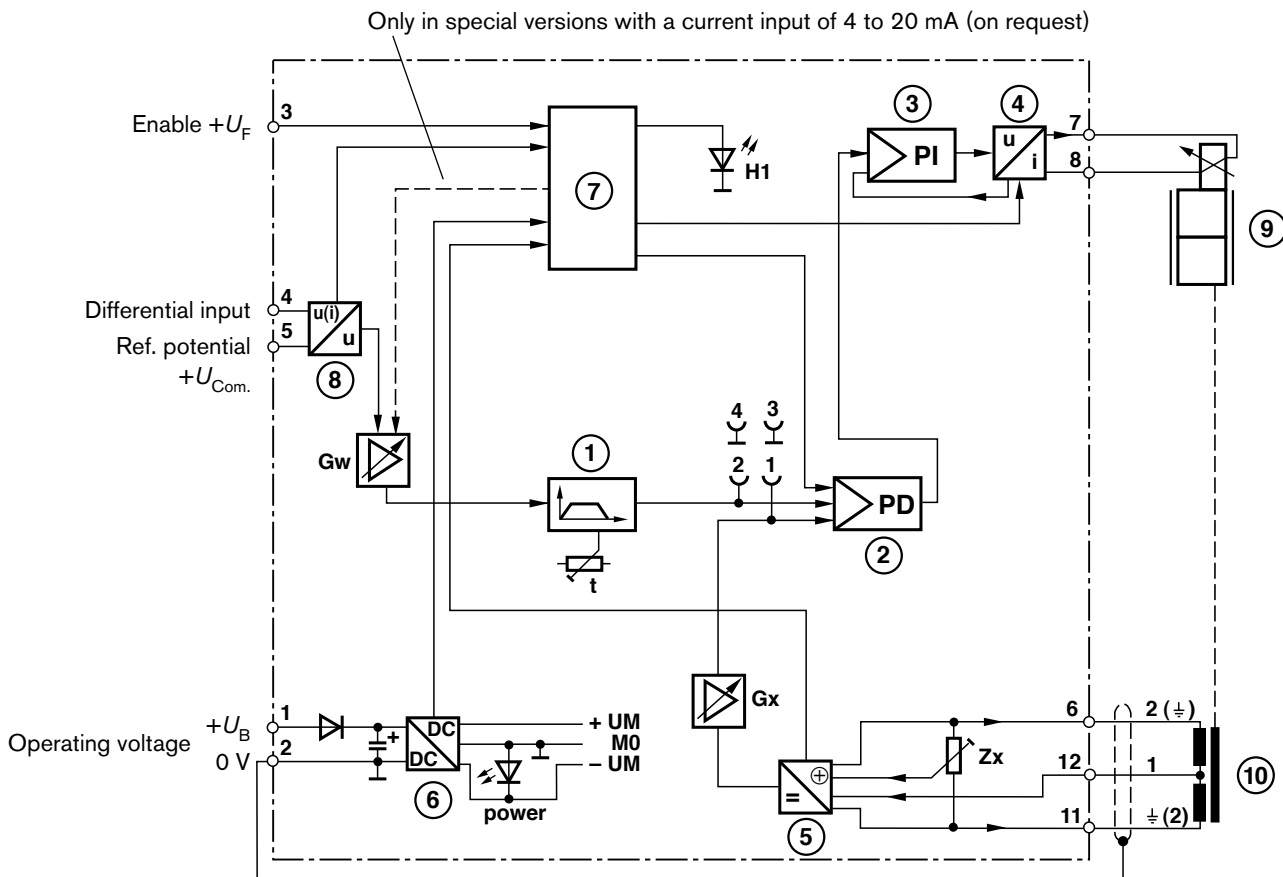

**Note!**  
 The connections to the position transducer are shown for clockwise rotation pumps („( )“ for anti-clockwise rotation pumps)

- |  |                                 |                                 |  |
|--|---------------------------------|---------------------------------|--|
| <b>1</b> Ramp generator                | <b>6</b> Power supply           | <b>1</b> Actual value 0 to -5 V | <b>H1</b> Multi-function display         |
| <b>2</b> Controller for spool position | <b>7</b> Monitoring             | <b>2</b> Com. value 0 to +5 V   | <b>Zx</b> Zero point position transducer |
| <b>3</b> Current controller            | <b>8</b> Differential amplifier | <b>K3</b> Measuring zero        | <b>Gw</b> Command value reduction        |
| <b>4</b> Output stage                  | <b>9</b> Proportional valve     | <b>K4</b> Measuring zero        | <b>Gx</b> Actual value matching          |
| <b>5</b> Oscillator/demodulator        | <b>10</b> Position transducer   |                                 | <b>t</b> Ramp time                       |

## Terminal connections

Operating voltage	$+U_B$	1	7	Solenoid connection
	0 V	2	8	
Enable	$U_F$	3	9	n. c.
Differential input	Ref. potential	4	10	n. c.
	$+U_{Soll}$	5	11	$\perp$
Position transducer connection <sup>1)</sup>	2	6	12	1

<sup>1)</sup> Applies to clockwise rotation pumps (see block circuit diagram)

### Connection cable (recommendation):

- Position transducer → 3-core cable, single screened, cross-section max. 1.5 mm<sup>2</sup>
- Solenoid connection → 2- or 4-core cable, single screened, cross-section max. 1.5 mm<sup>2</sup>
- Differential input → 2-core cable, single screened

## Unit dimensions (Dimensions in mm)

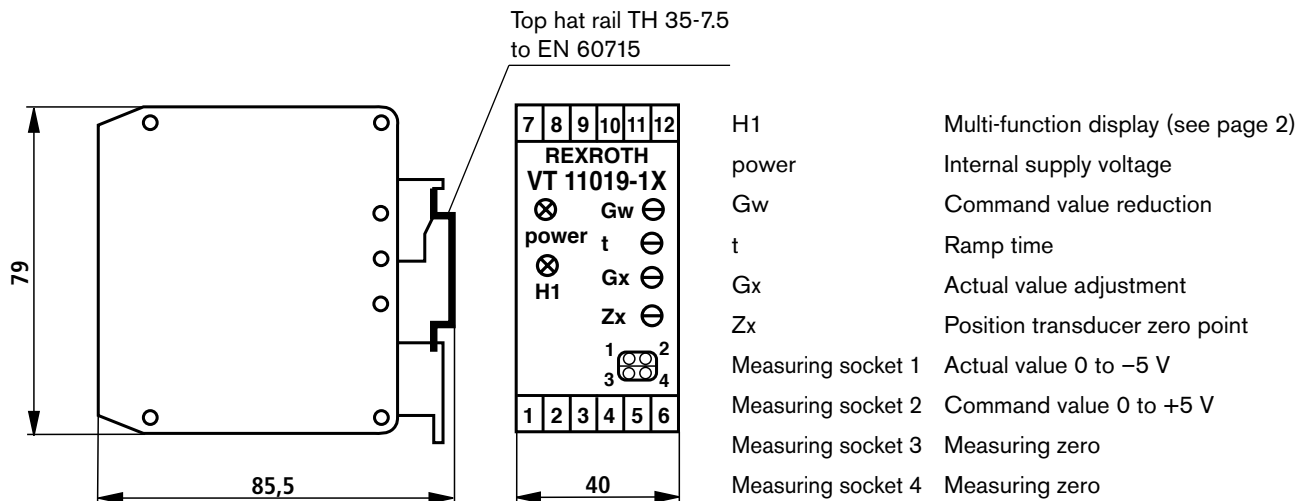

## Engineering / maintenance guidelines / additional information

---

- The amplifier module may only be connected when switched off!
- Do not connect the earth terminal of the inductive transducer to ground!
- Do not connect terminal 11 to ground, earth or screen; otherwise function disturbances may occur!  
(this was also not permitted with component series 10 units, but it did not lead to function disturbances.)
- Always screen command value lines and lines of the inductive transducer separately; screen open at valve; connect screen to 0V operating voltage (terminal 2) on module side only in order to avoid couplings!
- Do not lay lines near power lines!
- Do not use free wheel diodes in solenoid lines!
- Distance to antenna lines, radio sources and radar equipment must be at least 1 m!
- Because of the load current of the integrated smoothing capacitor external fuses must have slow blowing characteristics!
-  **Note!**
  - When using the differential input (command value as voltage signal) both inputs must always be switched on or off simultaneously!
  - The actual value adjustment (potentiometer „Gx“) is factory pre-calibrated!

**Notes**

---

## Notes

---