

RE 29 993/02.03

Replaces: 06.97

**Electrical amplifier for flow control with
servo-valves
Type VT- SR7**

Series 1X

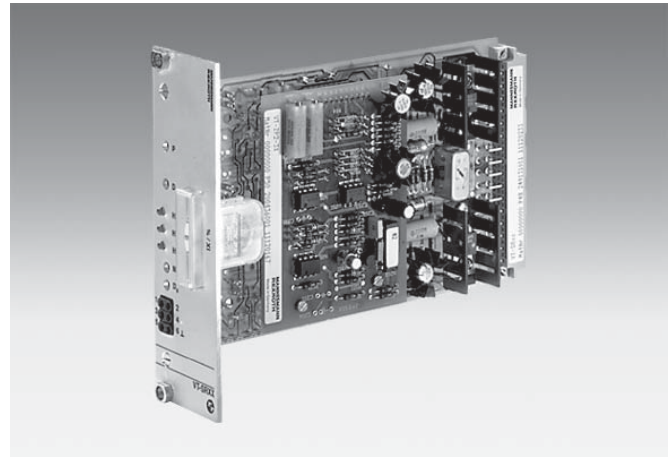

H/A/D 5657/97

Type VT-SR7-1X/...

Table of contents

Contents	Page		
Features	1	Block circuit diagram / pin assignment	3
Ordering code	1	Preferred types	4
Technical data	2	Engineering / maintenance notes / supplementary information	4
Functional description	2	Unit dimensions	4

Features

VT-SR7 amplifiers are used to control axial piston units of type A4VS...HS.

The assembly is fitted with an oscillator/demodulator for inductive position feedback and a PID-controller for controlling the swivel angle of the pump. The parameters for the controller are matched to the individual size of the axial piston unit.

The valve current is enabled by means of a relay call-up. The command value can be fed forward via the differential input or the command value input.

A measuring instrument installed in the front panel indicates the servo-valve current; $\pm 100\%$ corresponds to ± 60 mA.

Card holder:

– Type VT 3002-2X/32, see RE 29 928, single card holder without power supply unit

Power supply unit:

– Type VT-NE31-1X, see RE 29 929 compact power supply unit 115/230 VAC \AA ± 24 VDC, 7 VA

Ordering code

VT-SR7		- 1X /	/	*
Amplifier for flow control with servo-valves				Further details in clear text ¹⁾
Series 10 to 19 (10 to 19: unchanged technical data and pin assignment)	= 1X			
Without ± 15 V voltage regulator		= 0		
With ± 15 V voltage regulator		= 1		
				A4VS40HS = Axial piston unit size 40
				A4VS71HS = Axial piston unit size 71
				A4VS125HS = Axial piston unit size 125
				A4VS180HS = Axial piston unit size 180
				A4VS250HS = Axial piston unit size 250
				A4VS355HS = Axial piston unit size 355
				A4VS500HS = Axial piston unit size 500
				A4VS750HS = Axial piston unit size 750
				A4VS1000HS = Axial piston unit size 1000

¹⁾ For example: with/without PID-controller
For the additional PID-controller, the technical controller data must be specified.



© 2003

by Bosch Rexroth AG, Industrial Hydraulics, D-97813 Lohr am Main

All rights reserved. No part of this document may be reproduced or stored, processed, duplicated or circulated using electronic systems, in any form or by means, without the prior written authorisation of Bosch Rexroth AG. In the event of contravention of the above provisions, the contravening party is obliged to pay compensation.

Technical data (for applications outside these parameters, please consult us!)

Operating voltages:		
With voltage regulator	U_B	± 24 VDC
– Upper limit value	$u_O(t)_{\max}$	± 28 VDC
– Lower limit value	$u_O(t)_{\min}$	± 22 VDC
Without voltage regulator	$U_O; U_M$	± 24 VDC and ± 15 VDC (stabilised)
– Upper limit values	$u_O(t)_{\max}; u_M(t)_{\max}$	± 28 VDC; ± 15.2 VDC
– Lower limit values	$u_O(t)_{\min}; u_M(t)_{\min}$	± 22 VDC; ± 14.8 VDC
Power consumption (without valve) at $U_O = \pm 24$ V ¹⁾	I	< 150 mA
Inputs:		
– Command value 1	U_i	0 to ± 10 V ($R_i = 50$ k Ω)
– Command value 2 (with J9)	U_i	0 to ± 10 V ($R_i = 50$ k Ω)
– Actual position value	U_i	0 to ± 10 V ($R_i = 50$ k Ω)
– Enable	U_i	+ 24 V with J13; 0 V with J12 ($R_i = 700$ Ω ; relay circuit)
– Controller changeover	U_i	+ 24 V with J13; 0 V with J12 ($R_i = 700$ Ω ; relay circuit)
– Reserve relay	U_i	+ 24 V with J13; 0 V with J12 ($R_i = 700$ Ω ; relay circuit)
Outputs:		
– Regulated output voltage ¹⁾	U_M	± 15 V ± 2 %; 150 mA
– Valve current	I_{\max}	± 60 mA
– Valve current command value (with J10)	U_o	-10 V $\hat{=}$ + 60 mA (measuring output)
– Relay call-up voltage	U	+ 24 V (+ U_o)
Dither signal	f	340 Hz ($I_{SS} = 3$ mA)
Relay data:		
– Nominal voltage	U	+ 26 V
– Response voltage	U	> 13 V
– Release voltage	U	1.3 V to 6.5 V
– Switching time	t	< 4 ms
– Coil resistance (at 25 °C)	R	700 Ω
Type of connection		32-pin male connector, DIN 41 612, form D
Card dimensions		Euro-card 100 x 160 mm, DIN 41 494
Front panel dimensions:		
– Height		3 HE (128,4 mm)
– Width soldering side		1 TE (5.08 mm)
– Width component side		7 TE
Permissible ambient temperature range	J	0 to + 50 °C
Storage temperature range	J	- 20 to + 70 °C
Weight	m	0.3 kg

¹⁾ for version **with** voltage regulator

Functional description

VT-SR7 amplifiers operate with a push-pull output stage with bipolar transistors. The output of this output stage can be activated or deactivated using an enable circuit (relay K2). The enable is indicated by lighting up of LED "H2" on the front panel. The switching voltage of all relays is set to either 0 V or + U_O by means of jumpers J12 and J13 (factory setting + U_O).

The output stage consists of an I-controller with connected dither signal generator. The amplitude of the dither signal can be adjusted using R7. The input stage (current command value) is controlled via a PD-controller. The actual current value fed back is indicated by the instrument on the front panel.

The oscillator/demodulator is used for acquiring the position. It is designed as plug-in board, the parameters of which are adapted to the relevant size of the axial piston unit.

The position command value and actual position value are fed to the PD-controller, with the D-component acting **only** on the actual value (velocity feedback).

The zero point can be adjusted from the front panel using R3 ("NP").

The required symmetric operating voltage $\pm U_O$ is protected against reverse polarity. If the printed circuit board is not fitted with a voltage regulator for supplying the controller and displacement transducer electronics, an additional, stabilised auxiliary voltage $\pm U_M$ must be provided. The auxiliary voltage connection is protected against reverse polarity up to a maximum current of 1 A.

Optionally, the amplifier can be provided with a PID-controller (D-component acts **only** on the actual value). This controller can be used to superimpose a further closed control loop (e.g. for drive control). The P- and D-component can be adjusted on the front panel. The PID-controller configuration is customised and must therefore be indicated in clear text on the order. When dispatched, a special type designation is assigned to the amplifiers.

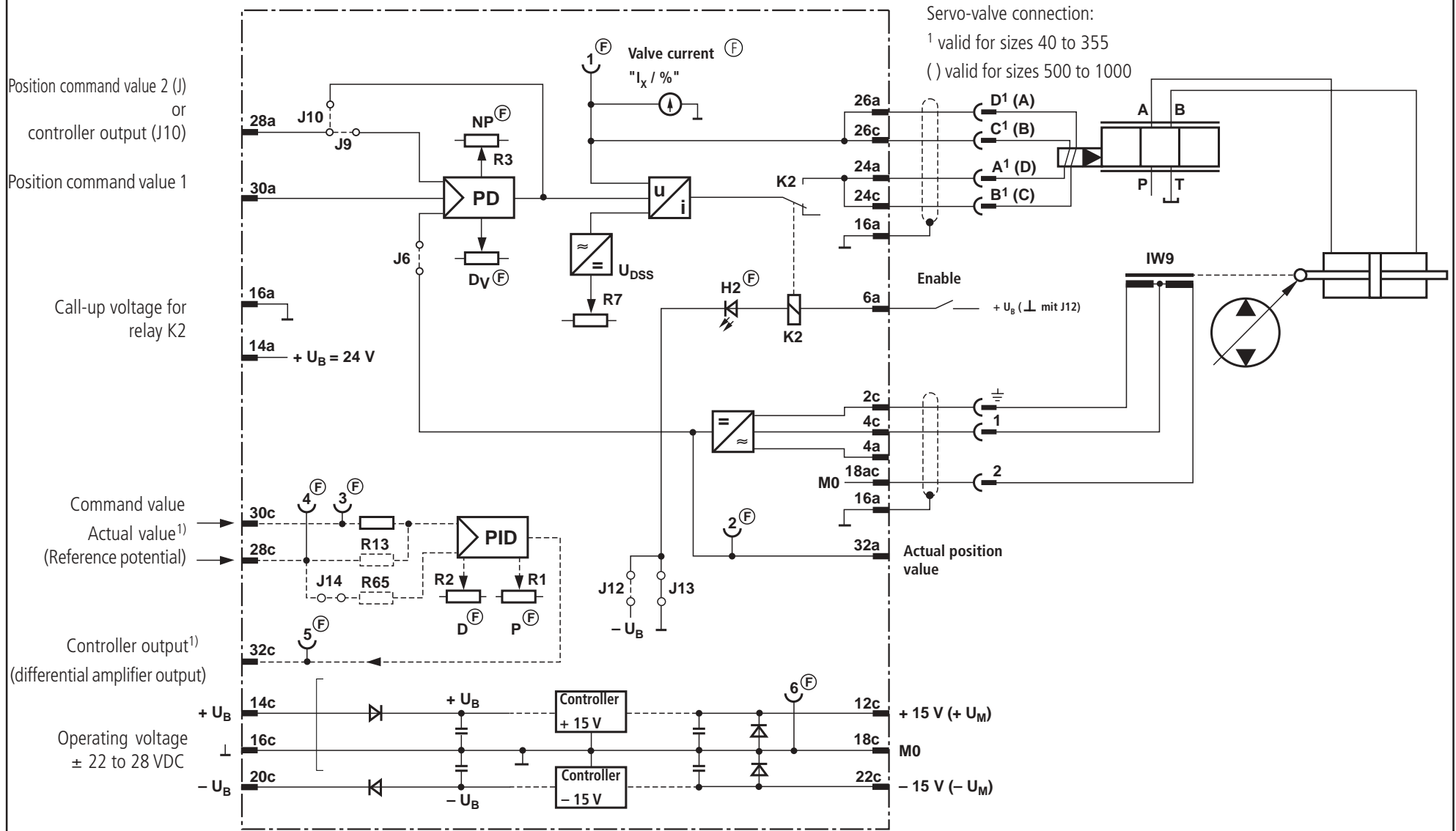

Servo-valve connection:
¹ valid for sizes 40 to 355
 () valid for sizes 500 to 1000

¹⁾ The controller input can be converted into a differential input by removing R13 and plugging in J14 and R65. (F) = On front panel

Preferred types

Material no.	Type
R900035612	VT-SR7-1X/0/A4VS.355HS
R900030717	VT-SR7-1X/0/A4VS.500HS
R900557769	VT-SR7-1X/1/A4VS.180HS
R900029274	VT-SR7-1X/1/A4VS.250HS
R900579280	VT-SR7-1X/1/A4VS.355HS
R900029181	VT-SR7-1X/1/A4VS.500HS

Engineering / maintenance notes / supplementary information

- The amplifier may only be plugged or unplugged when disconnected from the power supply!
- Command values may only be switched via relays with gold-plated contacts (small voltages, small currents)!
- For switching card relays (enable, controller changeover, reserve) use only contacts with a load-carrying capacity of ca. 40 V/ 50 mA.
- Always shield command value and actual value cables; leave one end of shield open and connect the card-sided end to the ground (\perp)!
- Do not lay signal cables near power cables!
- Recommendation:
 1. Also shield solenoid cables (one end to \perp)!
 2. For lengths up to 50 m use cable type LiYCY 1.5 mm², for greater lengths, please consult us!
- **Caution:** When pilot pressure is applied to the actuating equipment and relay K2 is deactivated or the voltage supply is disconnected, the pump may swivel to its maximum position!

Note: Electrical signals brought out via control electronics (e.g. actual value) must not be used for switching safety-relevant machine functions! (See also the European standard "Safety requirements for fluid power systems and components - Hydraulics", prEN 982.)

Unit dimensions (dimensions in mm)

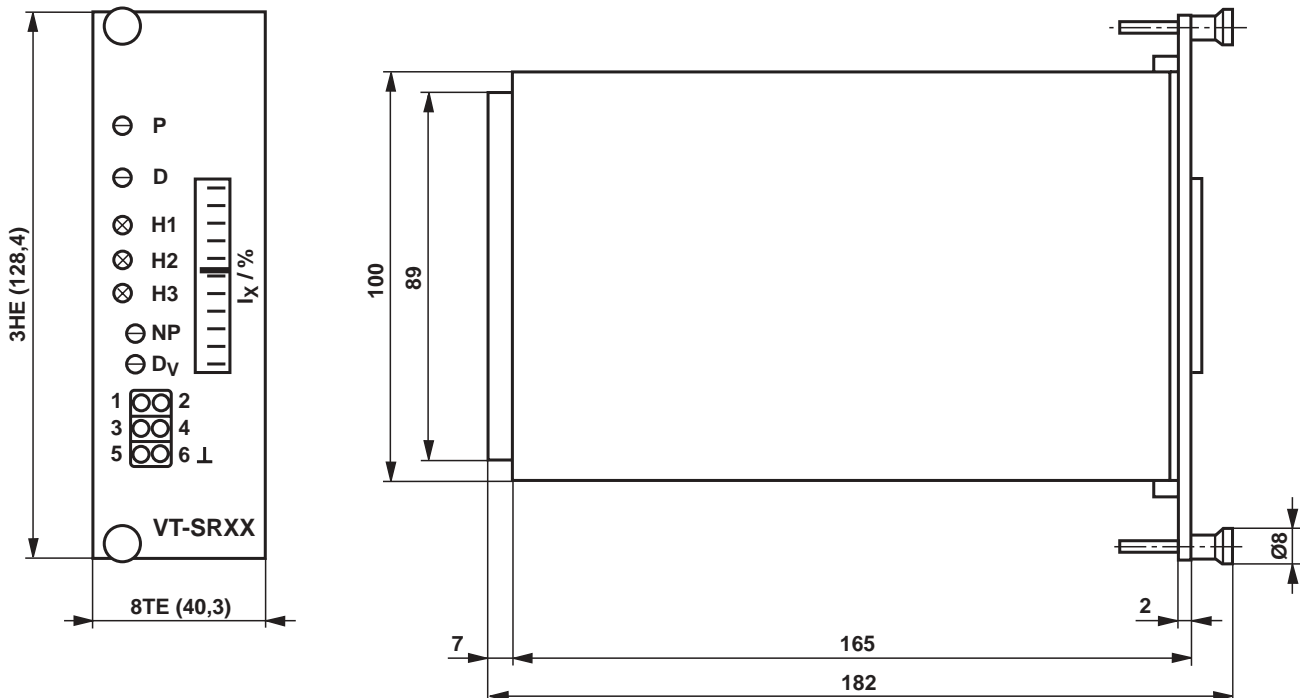

Bosch Rexroth AG Industrial Hydraulics

D-97813 Lohr am Main
 Zum Eisengießer 1 • D-97816 Lohr am Main
 Telefon 0 93 52 / 18-0
 Telefax 0 93 52 / 18-23 58 • Telex 6 89 418-0
 eMail documentation@boschrexroth.de
 Internet www.boschrexroth.de

Bosch Rexroth Limited

Cromwell Road, St Neots,
 Cambs, PE19 2ES
 Tel: 0 14 80/22 32 56
 Fax: 0 14 80/21 90 52
 eMail: info@boschrexroth.co.uk

The data specified above only serves to describe the product. No statements concerning a certain condition or suitability for a certain application can be derived from our information. The details stated do not release you from the responsibility for carrying out your own assessment and verification. It must be remembered that our products are subject to a natural process of wear and ageing.